

# DATA SHEET

## **PCF50732**

Baseband and audio interface for  
GSM

Objective specification  
File under Integrated Circuits, IC17

1999 May 03

## Baseband and audio interface for GSM

## PCF50732

<b>CONTENTS</b>	14	<b>LIMITING VALUES</b>
1 FEATURES	15	THERMAL CHARACTERISTICS
2 APPLICATIONS	16	DC CHARACTERISTICS
3 GENERAL DESCRIPTION	17	AC CHARACTERISTICS
4 ORDERING INFORMATION	18	FUNCTIONAL CHARACTERISTICS
5 QUICK REFERENCE DATA	18.1	Baseband transmit (BSI to TXI/Q)
6 BLOCK DIAGRAM	18.2	Baseband receive (RXI/Q to BSI)
7 PINNING	18.3	Voice band transmit (microphone to ASI)
8 FUNCTIONAL DESCRIPTION	18.4	Voice band receive (ASI to earphone)
8.1 General	18.5	Auxiliary digital-to-analog converters
8.2 Baseband and voice band reference voltages	18.6	Auxiliary analog-to-digital converters: AUXADC1, AUXADC2, AUXADC3 and AUXADC4
9 BASEBAND CODEC	18.7	Typical total current consumption
9.1 Baseband transmit path	18.8	Typical output loads
9.2 Baseband receive path	19	<b>APPLICATION INFORMATION</b>
9.3 Baseband Serial Interface (BSI)	19.1	Wake-up procedure from Sleep mode
10 VOICE BAND CODEC	19.2	Microphone input connection and test set-up
10.1 Voice band receive path	20	<b>PACKAGE OUTLINES</b>
10.2 Voice band transmit path	21	<b>SOLDERING</b>
10.3 Voice band digital circuitry	21.1	Introduction to soldering surface mount packages
11 AUXILIARY FUNCTIONS	21.2	Reflow soldering
11.1 Automatic Gain Control (AGC): AUXDAC1	21.3	Wave soldering
11.2 Automatic Frequency Control (AFC): AUXDAC2	21.4	Manual soldering
11.3 Power ramping: AUXDAC3	21.5	Suitability of surface mount IC packages for wave and reflow soldering methods
11.4 Auxiliary analog-to-digital converter (AUXADC)	22	<b>DEFINITIONS</b>
12 CONTROL SERIAL INTERFACE (CSI)	23	<b>LIFE SUPPORT APPLICATIONS</b>
12.1 The serial interface		
12.2 Control Serial Interface (CSI) timing characteristics		
12.3 Control register block		
13 VOICE BAND SIGNAL PROCESSOR (VSP)		
13.1 Hardware description		
13.2 VSP assembler language		
13.3 Descriptions of the VSP instruction set		
13.4 The assembler/emulator		

## Baseband and audio interface for GSM

## PCF50732

### 1 FEATURES

- Low power and low voltage device in 0.25 micron CMOS technology; supply voltage: analog 2.7 V (typical) and digital 1.5 V (typical)
- Compatible with GSM phase 2 and DCS1800 recommendations
- Complete in-phase and quadrature component interface paths between the Digital Signal Processor (DSP) and RF circuitry
- Complete linear PCM CODEC for audio signal conversion between earphone/microphone and DSP
- Four auxiliary analog inputs for measurement purposes (e.g. battery monitoring)
- Three auxiliary analog outputs for control purposes (i.e. AFC, AGC and power ramping control)
- Separate baseband, audio and control serial interfaces
- Voice band Signal Processor (VSP) for flexible audio data processing.

### 2 APPLICATIONS

The CMOS integrated circuit PCF50732, Baseband and audio interface for GSM, is dedicated to wireless telephone handsets conforming to the GSM recommendations phases 1 and 2, DCS1800 and PCS1900.

### 3 GENERAL DESCRIPTION

The baseband CODEC is a complete interface circuit between the RF part in a mobile communication handset and the Digital Signal Processor (DSP). It consists of three parts:

- The **receive path**, which transforms the quadrature signals from the RF (I/Q) to digital signals
- The **transmit path**, which transforms a bitstream to analog quadrature signals for the RF devices

### 4 ORDERING INFORMATION

TYPE NUMBER	PACKAGE		
	NAME	DESCRIPTION	VERSION
PCF50732H	LQFP48	plastic low profile quad flat package; 48 leads; body 7 × 7 × 1.4 mm	SOT313-2

- The digital **Baseband Serial Interface (BSI)**, which exchanges baseband data between the PCF50732 and the digital signal processor. The interface also includes signals to power-up and power-down the baseband transmit (TX) and receive (RX) paths.

The voice band CODEC is a complete analog front-end circuit. It consists of four parts:

- The **receive path**, which converts a digital signal to an analog signal for an earpiece, an external loudspeaker or a buzzer
- The **transmit path**, which receives the analog external signal from a microphone and converts it into a digital signal
- The **Voice band Signal Processor (VSP)**, which filters the voice band data
- The digital **Audio Serial Interface (ASI)**, which connects the digital linear PCM signals of the receive and transmit paths to an external DSP. The voice band data is coded in 16-bit linear PCM twos complement words.

The **auxiliary Analog-to-Digital Converter (ADC)** section consists of four input channels specified for battery management applications.

The **auxiliary Digital-to-Analog Converter (DAC)** section consists of three DACs for Automatic Gain Control (AGC), for Automatic Frequency Control (AFC) and for power ramping.

The **Control Serial Interface (CSI)** is used to program a set of control registers, to store the power amplifier ramping characteristics into the dedicated RAM and to transmit auxiliary ADC values to the DSP. It also controls switches, modes and power status of the different parts of the IC.

## Baseband and audio interface for GSM

## PCF50732

## 5 QUICK REFERENCE DATA

SYMBOL	PARAMETER	CONDITIONS	MIN.	TYP.	MAX.	UNIT
$V_{DDD}$	digital supply voltage		1.0	1.5	2.75	V
$V_{DDA}$	analog supply voltage	$V_{DDA} \geq V_{DDD}$	2.5	2.7	2.75	V
$I_{DDA}$	analog supply current	$V_{DDD} = 1.5$ V; $V_{DDA} = 2.7$ V; RXON active	–	3.5	–	mA
$P_{av}$	average power consumption	$V_{DDD} = 1.5$ V; $V_{DDA} = 2.7$ V; note 1	–	15	–	mW
$I_{stb(tot)}$	total standby current		–	10	–	$\mu$ A
$f_{clk}$	master clock frequency		–	13.0	–	MHz
$T_{amb}$	operating ambient temperature		–40	+27	+85	$^{\circ}$ C

**Note**

1. Without load on audio outputs EARP, EARN, AUXSP and BUZ.

Baseband and audio interface for GSM

PCF50732

6 BLOCK DIAGRAM

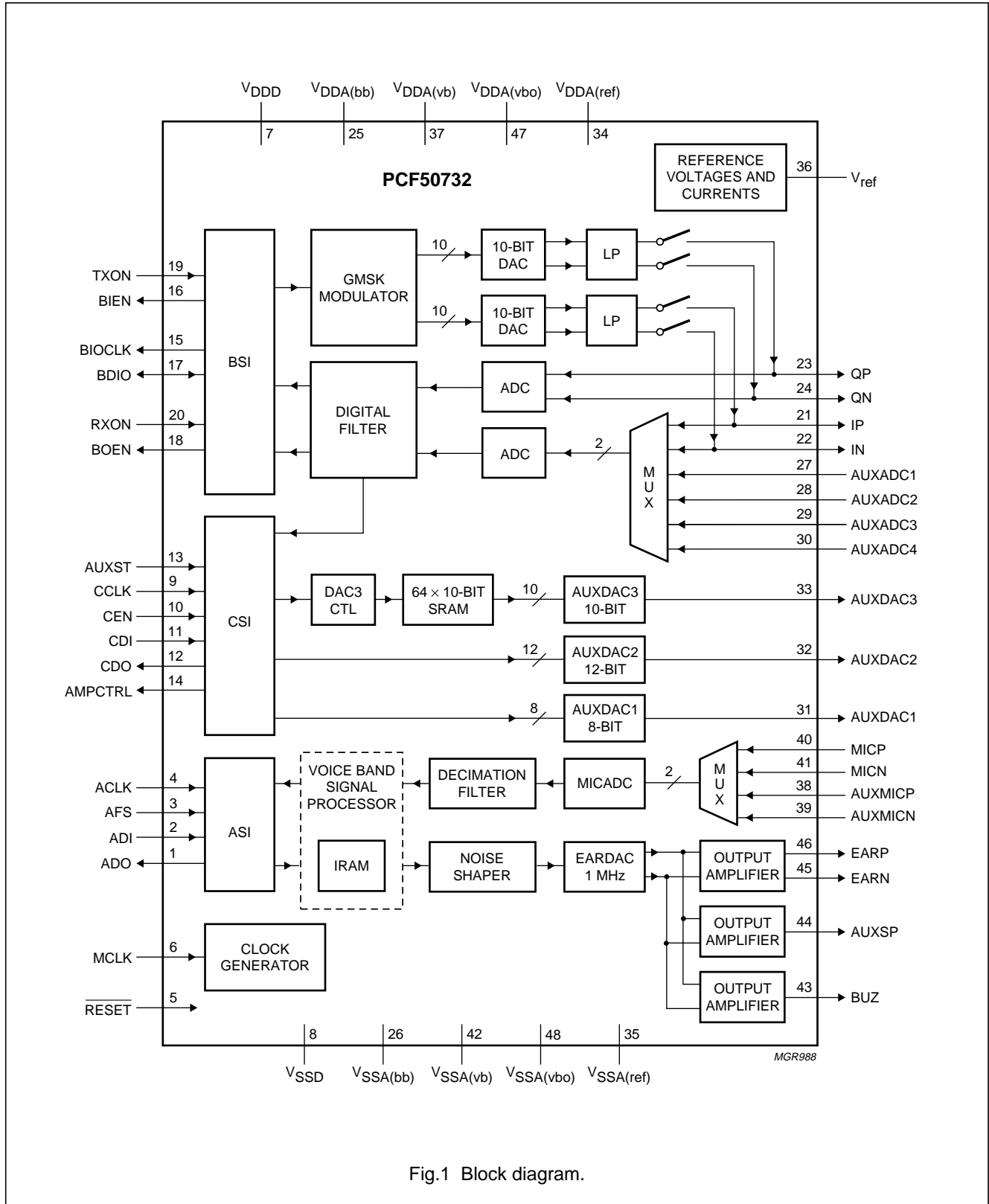

Fig.1 Block diagram.

## Baseband and audio interface for GSM

## PCF50732

## 7 PINNING

SYMBOL	PIN					DESCRIPTION
	NR.	TYPE <sup>(1)</sup>	ACTIVE LEVEL	ACTIVE EDGE	I <sub>DD</sub>	
ADO	1	O/TS	–	–	1.5 mA	audio digital interface PCM data output to DSP
ADI	2	I	–	–	–	audio digital interface PCM data input from DSP
AFS	3	I	–	rising	–	audio digital interface PCM frame synchronization signal from DSP
ACLK	4	I	–	rising	–	audio digital interface PCM clock signal from DSP
RESET	5	I	LOW	–	–	asynchronous reset input
MCLK	6	I	–	rising	–	low-swing master clock input; f <sub>clk</sub> = 13 MHz; integrated capacitive coupling
V <sub>DDD</sub>	7	P	–	–	–	digital power supply
V <sub>SSD</sub>	8	G	–	–	–	digital ground
CCLK	9	I	–	falling	–	control bus clock input from DSP
CEN	10	I	LOW	–	–	control bus data enable from DSP
CDI	11	I	–	–	–	control bus data input from DSP
CDO	12	O/TS	–	–	1.5 mA	control bus data output to DSP
AUXST	13	I	HIGH	–	–	status control signal for activation of AUXDAC1, AUXDAC2 and MCLK input
AMPCTRL	14	O	–	–	1.5 mA	general purpose output pin
BIOCLK	15	O/TS	–	–	3 mA	baseband interface data clock
BIEN	16	O	LOW	–	1.5 mA	baseband transmit interface data enable signal
BDIO	17	I/O	–	–	1.5 mA	baseband interface data I/O from/to DSP
BOEN	18	O	LOW	–	1.5 mA	baseband receive interface data enable signal
TXON	19	I	HIGH	–	–	baseband transmit path activation signal
RXON	20	I	HIGH	–	–	baseband receive path activation signal
IP	21	I/O	–	–	–	(I) baseband differential positive input/output to IF circuit
IN	22	I/O	–	–	–	(I) baseband differential negative input/output to IF circuit
QP	23	I/O	–	–	–	(Q) baseband differential positive input/output to IF circuit
QN	24	I/O	–	–	–	(Q) baseband differential negative input/output to IF circuit
V <sub>DDA(bb)</sub>	25	P	–	–	–	baseband power supply (analog)
V <sub>SSA(bb)</sub>	26	G	–	–	–	baseband ground (analog)
AUXADC1	27	I	–	–	–	auxiliary ADC input 1 for battery voltage measurement
AUXADC2	28	I	–	–	–	auxiliary ADC input 2
AUXADC3	29	I	–	–	–	auxiliary ADC input 3
AUXADC4	30	I	–	–	–	auxiliary ADC input 4
AUXDAC1	31	O	–	–	–	auxiliary DAC output for AGC; max. load 50 pF // 2 kΩ
AUXDAC2	32	O	–	–	–	auxiliary DAC output for AFC; max. load 50 pF // 10 kΩ

## Baseband and audio interface for GSM

## PCF50732

SYMBOL	PIN					DESCRIPTION
	NR.	TYPE <sup>(1)</sup>	ACTIVE LEVEL	ACTIVE EDGE	I <sub>DD</sub>	
AUXDAC3	33	O	–	–	–	auxiliary DAC output for power ramping; maximum load 50 pF, ±600 µA
V <sub>DDA(ref)</sub>	34	P	–	–	–	reference voltage power supply (analog)
V <sub>SSA(ref)</sub>	35	G	–	–	–	reference voltage ground (analog)
V <sub>ref</sub>	36	I/O	–	–	–	band gap reference voltage noise decoupling
V <sub>DDA(vb)</sub>	37	P	–	–	–	voice band voltage power supply
AUXMICP	38	I	–	–	–	auxiliary microphone differential positive input
AUXMICN	39	I	–	–	–	auxiliary microphone differential negative input
MICP	40	I	–	–	–	microphone differential positive input
MICN	41	I	–	–	–	microphone differential negative input
V <sub>SSA(vb)</sub>	42	G	–	–	–	voice band ground
BUZ	43	O	–	–	–	buzzer output
AUXSP	44	O	–	–	–	auxiliary speaker output
EARN	45	O	–	–	–	earphone differential negative output
EARP	46	O	–	–	–	earphone differential positive output
V <sub>DDA(vbo)</sub>	47	P	–	–	–	voice band output buffer voltage power supply (analog)
V <sub>SSA(vbo)</sub>	48	G	–	–	–	voice band output buffer ground (analog)

**Note**

1. O/TS = 3-state output.

Baseband and audio interface for GSM

PCF50732

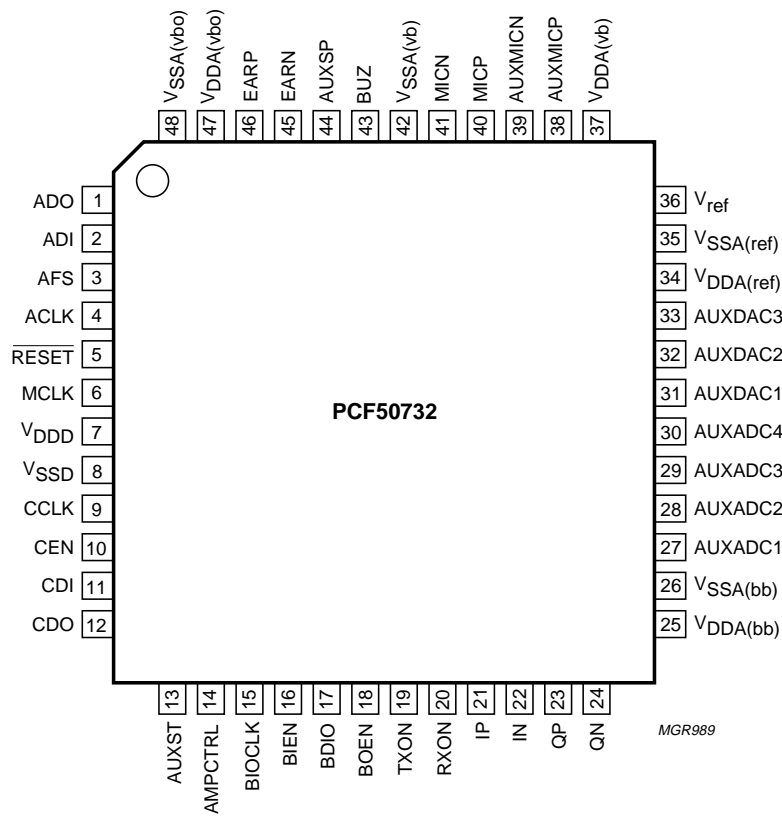

Fig.2 Pin configuration.



## Baseband and audio interface for GSM

## PCF50732

### 8 FUNCTIONAL DESCRIPTION

This chapter gives a brief overview of the device. The detailed functional description can be found in the following chapters:

- Chapter 9 “Baseband CODEC”
- Chapter 10 “Voice band CODEC”
- Chapter 11 “Auxiliary functions”
- Chapter 12 “Control Serial Interface (CSI)”
- Chapter 13 “Voice band Signal Processor (VSP)”.

#### 8.1 General

As low power consumption in mobile telephones is a very important issue, all the circuit parts in the PCF50732 can be powered-on/off either by means of the external signals AUXST, TXON or RXON, or by programming the respective register bits in the Control Serial Interface (CSI).

The most important signal for the digital and analog circuit functions in the PCF50732 is the DAC enable signal AUXST, which allows to activate AUXDAC1 (AGC) and AUXDAC2 (AFC), as well as the low-swing master clock input MCLK. AUXST must be active (HIGH) and **V<sub>DDA</sub> must be stable** (see also Section 18.1) to allow the master clock to access different circuit parts after a reset ( $\overline{\text{RESET}}$  active). AUXDAC1 and AUXDAC2 are only activated if their related power-on bit is set. AUXDAC1 is default off, AUXDAC2 is default on.

$\overline{\text{RESET}}$  must be active during at least 3 MCLK cycles, with AUXST active, to ensure a correct initialisation of all the digital circuitry of the PCF50732. Since  $\overline{\text{RESET}}$  is asynchronous even small spikes of a few nanoseconds can cause partial resets.

For power supply noise interference reduction, a pair of power supply and ground pins are provided for the:

- Baseband analog:  $V_{\text{DDA}(\text{bb})}/V_{\text{SSA}(\text{bb})}$
- Voice band analog:  $V_{\text{DDA}(\text{vb})}/V_{\text{SSA}(\text{vb})}$
- Voice band output drivers:  $V_{\text{DDA}(\text{vbo})}/V_{\text{SSA}(\text{vbo})}$
- DC reference voltages and currents:  $V_{\text{DDA}(\text{ref})}/V_{\text{SSA}(\text{ref})}$
- Digital circuitry:  $V_{\text{DDD}}/V_{\text{SSD}}$ .

All  $V_{\text{SS}}$  pins are connected internally.  $V_{\text{DDD}}$  is the digital supply.  $V_{\text{DDA}(\text{bb})}$ ,  $V_{\text{DDA}(\text{vb})}$ ,  $V_{\text{DDA}(\text{vbo})}$ , and  $V_{\text{DDA}(\text{ref})}$  are analog supplies, and are referred to as  $V_{\text{DDA}}$  throughout this document. These analog supplies must be connected externally.

#### 8.2 Baseband and voice band reference voltages

The reference voltage  $V_{\text{ref}}$  is generated on-chip by a band gap voltage reference circuit and is available at pin  $V_{\text{ref}}$ .

As  $V_{\text{ref}}$  is used as reference for most of the internal analog circuitry, noise must be kept as low as possible by connecting an external decoupling capacitor at this pin.

The voltage at  $V_{\text{ref}}$  is buffered to generate the baseband and voice band reference voltage  $V_{\text{ref}}$  as well as internal references for the different functions, such as the auxiliary and the transmit DACs.

### 9 BASEBAND CODEC

The baseband CODEC is a complete interface circuit between the RF part in a mobile communication handset and the digital signal processor. It consists of three parts:

- The **transmit path**, which converts a bitstream to analog quadrature signals for the RF devices
- The **receive path**, which transforms the quadrature signals of the IF chip (I/Q) to digital signals
- The digital **baseband serial interface**, which exchanges baseband data between the PCF50732 and the DSP. The interface also includes signals to power-up and power-down the baseband transmit (TX) and receive (RX) paths.

#### 9.1 Baseband transmit path

The baseband transmit path consists of three parts:

- **GMSK modulator**: generation of a Gaussian Minimum Shift Keying (GMSK) signal
- **10-bit DACs**: digital-to-analog converters for the I and Q components of the GMSK signal
- **Low-pass filters**: analog reconstruction low-pass filters for the output of the DACs.

The requirements of the transmit path of a GSM terminal are given by “*GSM recommendation 05.05*”:

- Phase RMS error  $<5^\circ$
- Phase peak error  $<20^\circ$
- Amplitude error  $< \pm 1$  dB.

Nevertheless the performance of the PCF50732 is far better than these figures indicate; see Section 18.1.

## Baseband and audio interface for GSM

## PCF50732

### 9.1.1 GMSK MODULATOR

The input signal of the GMSK modulator is a bitstream coming from the baseband serial interface, with a sampling frequency of 270.833 kHz. Typically 148 bits are modulated during a normal burst, and 88 bits during an access burst. Using this bitstream, the GMSK modulator generates digital I and Q components as described in "GSM recommendation 05.04".

This is done in three steps:

1. First the incoming bitstream is differentially encoded by an EXOR operation on the actual bit and the previous bit
2. The instantaneous phase ( $\varphi$ ) is calculated using a gaussian filter with an impulse response of 4 taps
3. A look-up table provides the cosine (I component) and the sine values (Q component) of the phase ( $\varphi$ ).

The look-up table also interpolates the signal to a 16 times higher frequency (4.333 MHz).

### 9.1.2 10-BIT DACs

The two 10-bit DACs are working at a sampling rate of 4.3333 MHz. They convert the digital I and Q components of the GMSK modulator to differential analog I and Q signals.

### 9.1.3 LOW-PASS FILTER

The analog output signals of the DACs are filtered by analog reconstruction low-pass filters.

These filters remove high frequency components of the DAC output signals and attenuate components around the 4.3333 MHz sampling frequency. The low-pass filters have a cut-off frequency of approximately 300 kHz, with very linear phase behaviour in the pass band.

## 9.2 Baseband receive path

The baseband receive path consists of two parts:

- **Receive ADC:**  $\Sigma\Delta$  analog-to-digital converters
- **Decimation filter:** digital decimation filters for I and Q.

The baseband receive section can be switched between two modes of operation:

- **ZIF (zero IF) mode** for radio sections, which convert the receive signal down to baseband. In this mode the ADC is sampled at 6.5 MHz, the decimation filter samples down by a factor of 24 with a pass band as specified in Fig.3. The serial interface output BDIO delivers  $2 \times 12$ -bit values for I and Q components at 270.833 kHz.
- **NZIF (near zero IF) mode** for radio sections, which converts the receive signal down to a centre frequency of 100 kHz. In this mode the ADC is sampled at 13 MHz, the decimation filter samples down by a factor of 24 with a pass band as specified in Fig.3. The serial interface output BDIO delivers  $2 \times 12$ -bit values for I and Q components at 541.667 kHz.

### 9.2.1 RECEIVE ADC

The receive ADCs are  $\Sigma\Delta$  analog-to-digital converters that convert differential input signals into 1-bit data streams with a sampling frequency of 6.5 or 13 MHz.

### 9.2.2 DIGITAL DECIMATION FILTER

Digital filtering is required for:

- Suppression of out-of-band noise produced by the  $\Sigma\Delta$  ADC
- Decimation of the sampling rate (6.5 or 13 MHz) by 24
- System level filtering.

The digital filtering is performed by a digital FIR filter with a group delay for this running average filter of approximately 23 or 11.5  $\mu$ s respectively. The filter uses twos complement arithmetic.

Baseband and audio interface for GSM

PCF50732

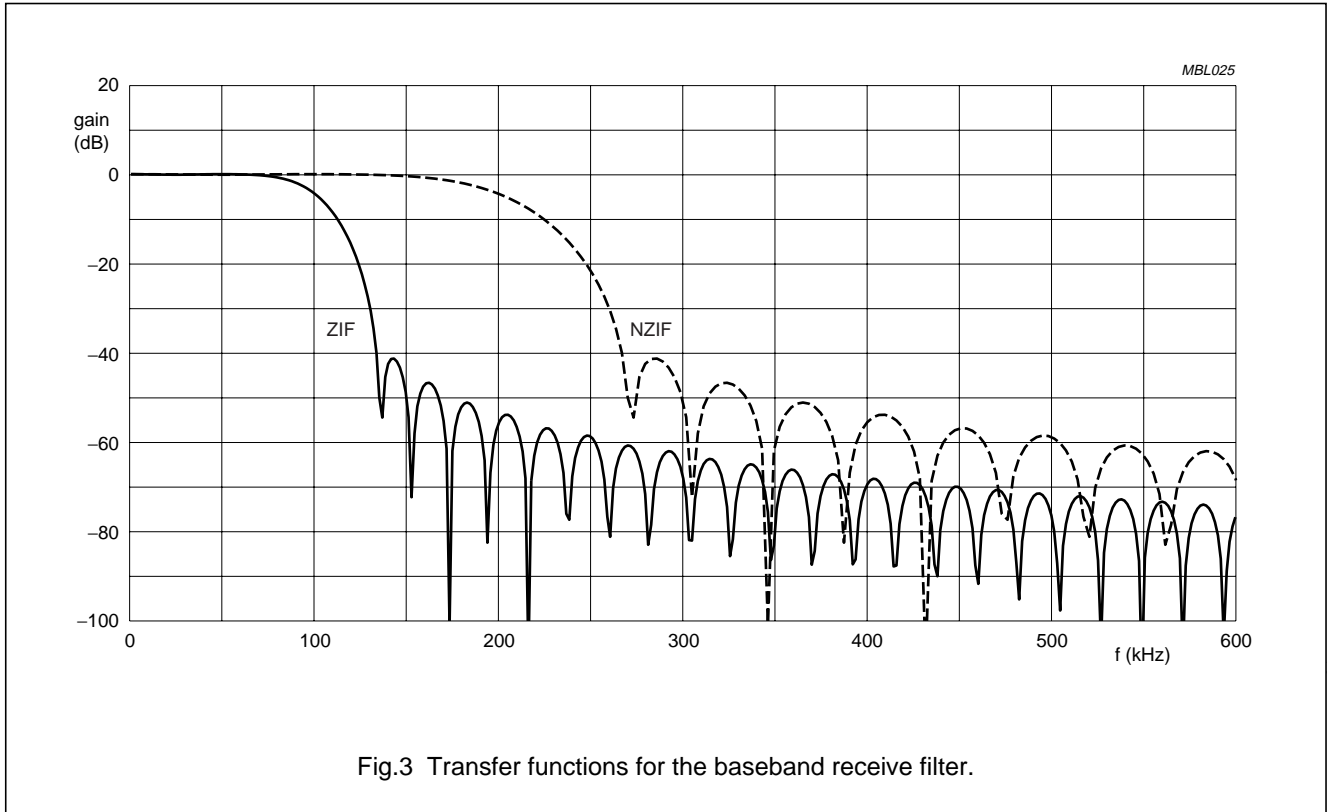

Fig.3 Transfer functions for the baseband receive filter.

9.3 Baseband Serial Interface (BSI)

9.3.1 OVERVIEW

The digital part of the baseband consists of a receive section and a transmit section. The receive section is a FIR filter that reduces the 6.5 MHz (13 MHz for NZIF mode) bitstream from the sigma-delta converters into 2 × 12-bit values at 270.833 kHz (541.667 kHz for NZIF mode).

The transmit section converts the 270.833 kHz data stream from the DSP into a GMSK signal sampled at 4.333 MHz. The 10-bit I and Q signals are then fed into two 10-bit DACs. The power ramping signal is also generated by the transmit section with the 10-bit AUXDAC3 block.

9.3.2 TRANSMIT PATH BLOCK DESCRIPTION

9.3.2.1 Transmit serial interface

The power-up of the BSI transmit path is controlled via the TXON pin. When TXON is pulled HIGH, the transmit path recovers from power-down. The MCLK/48 = 270.833 kHz output signal BIOCLK is activated. When the BIEN0 period has elapsed the output signal BIEN goes LOW and the bits to be transmitted are clocked out of the DSP.

BIEN0 must be at least 10 quarterbits long to allow settling of the analog filters. Bits are clocked out of the DSP by the falling edge and clocked into the PCF50732 by the rising edge of BIOCLK. After the BIEN1 period has elapsed, BIEN is set HIGH again and transmission from the DSP ends. Logic 1s are modulated whenever BIEN is HIGH and the baseband transmit (BBTX) block is active. Values for BIEN0 and BIEN1 can be set in the Burst control register.

Figure 5 shows the timing for the BSI data transmission. In power-down the de-asserted value of BIOCLK is high-Z and BIEN is HIGH. Typical connection to the system DSP is defined in Table 1.

Table 1 Connection of BSI transmit signals to PCF5087X

PCF50732		PCF5087X	
PIN	I/O	PIN	I/O
TXON	I	RFSIG[y]	O
BDIO	I/O	SIOXD	I/O
BIEN	O	SOXEN_N	I
BIOCLK	O	SIOXCLK	I

## Baseband and audio interface for GSM

## PCF50732

## 9.3.2.2 Power ramping controller

The PCF50732 fully supports all multislot modes which do not require full duplex operation or more than two consecutive transmit bursts. In this specification double burst mode is used for all supported multislot modes while single burst mode supports the normal GSM modes.

The power ramping controller drives the power amplifier output envelope.

In each transmit (TX) burst one ramp-up and one ramp-down will be carried out. In multislot mode one intermediate ramp will be carried out in addition to ramp-up and ramp-down. Each ramp consists of 16 discrete step values that are sent to the DAC3. Each step's duration is 2 quarterbits which translates into 8-bit long ramps. The DAC3 output is in 3-state whenever it is powered down. The ramping step values are stored in a  $64 \times 10$ -bit RAM as shown in Table 2.

In order to initialize AUXDAC3 it is necessary to write into the RAM all 32 (or 48 in multislot mode) DAC3 output values. Filling the RAM is normally done by writing a logic 0 to the address sub-register of the Burst control register, after which 32 or 48 values, depending on multislot mode, can be written into the data sub-register of the Burst control register. Writing to the DAC3 RAM is only possible when the DAC3 is powered off.

Total number of CSI-accesses is therefore 33 for a normal burst and 49 for a double burst.

An autoincrement feature will store these data into the correct RAM positions.

The value after power-up of DAC3 will always be equal to the value of RAM location 47.

AUXDAC3 timing is controlled by the Burst control register. This contains the following sub-registers:

- The **RU register** containing the delay in number of quarterbit cycles from the assertion of TXON to the start of the power-up ramping; default value is 0
- The **RM register** containing the delay in number of quarterbit cycles from the assertion of TXON to the start of the intermediate power ramp; default value is 0. RM is only used in case of multislot mode
- The **RD register** containing the delay in number of quarterbit cycles from the assertion of TXON to the start of the power-down ramping; default value is 0
- DAC3 burst RAM address register
- DAC3 burst RAM data register
- Single/double burst mode register: normal mode or multislot mode selection flag.

After TXON goes HIGH and a time equal to RU quarterbit periods has elapsed, power ramp-up is done.

After a time period equal to RD quarterbits has elapsed power ramp-down is initiated.

The AUXDAC3 output is also shown in Fig.4.

Values for RU (ramp-up) and RD (ramp-down) can be set in the Burst control register of the control serial interface. RD must be greater than RU + 32. RU and RD range from 0 to 4000 QB (quarterbit). The register offers the possibility to enter codes up to 4095.

The GMSK modulator is active for a period of 2 clock cycles after the ramp-down or for the length of the TXON burst, whichever is longer.

Multislot (high speed switched data mode) can be selected by setting the appropriate bit in the Burst control register. In multislot mode an intermediate ramping step is done. This intermediate step is started after a time period equal to RM quarterbits has elapsed. A value for RM (intermediate ramp) is also set using the Burst control register. The following conditions must be true:

$$RU + 32 < RM \text{ and } RM + 32 < RD.$$

**Table 2** AUXDAC3 RAM contents

RAM ADDRESS	DATA
0 to 15	ramp-up data
16 to 31	intermediate ramp data
32 to 47	ramp-down data
48 to 64	not used

**Table 3** Power ramping timing characteristics

SYMBOL	VALUE	COMMENTS <sup>(1)</sup>
$t_0$	$12t_1$	one quarterbit (QB)
$t_{ru}$	RU register	0 to 4000 QB
$t_{im}$	RM register	RU + 32 to 4000 QB
$t_{rd}$	RD register	RM + 32 to 4000 QB
$t_{rup}, t_{rim}, t_{rdo}$	$32t_0$	8 bits; 32 QB

**Note**

1. QB: Quarterbit, usually referred to the time needed for one quarter of a GSM baseband bit, i.e. a frequency of  $\frac{1}{12} \times 13$  MHz.

Baseband and audio interface for GSM

PCF50732

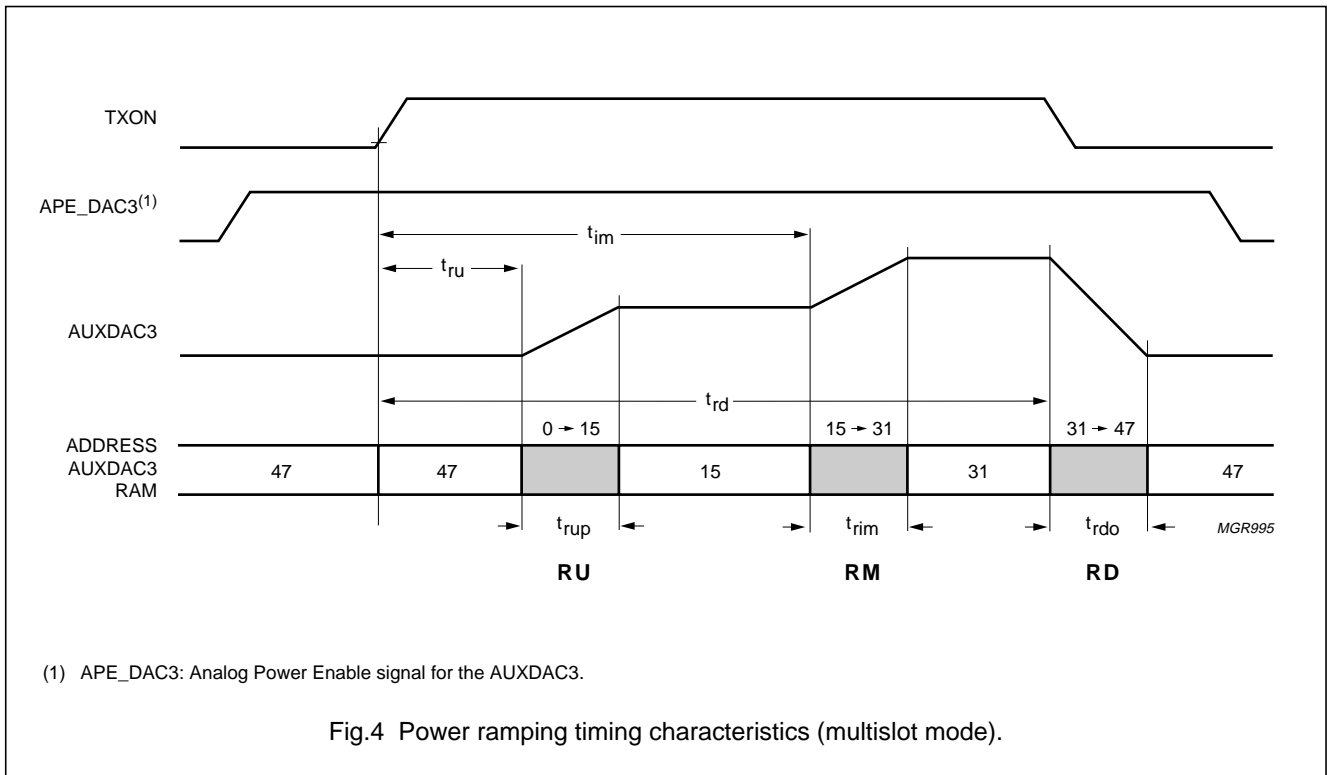

9.3.3 RECEIVER PATH BLOCK DESCRIPTION

9.3.3.1 Receive serial interface

The baseband serial interface sends the digital signal of the receive path to a digital signal processor. It also takes the digital bitstream from the digital signal processor and transmits it via the baseband CODEC.

The baseband reception and transmission are active in bursts. A normal burst has a length of 548 μs. The frame rate of bursts is 4.615 ms. Using a normal traffic channel, one burst for each frame is transmitted and two bursts are received. To save as much power as possible, the transmit path and the receive path of the PCF50732 are in power-up mode only during the transmission or reception bursts respectively.

The power-up of the receive section is controlled via the RXON pin or RXON bit. When RXON is driven HIGH, the receive section recovers from power-down and the output clock BIOCLK is activated. After a settling delay of 52 μs (ZIF mode, analog circuitry + decimation filter settling time), BOEN goes LOW to transfer the first 12-bit I and Q words. The settling time is only 26 μs in NZIF mode.

Bits are clocked out of the PCF50732 by the falling edge, and clocked into the DSP by the rising edge of BIOCLK. In normal bursts 148 I/Q pairs are read from the PCF50732.

When RXON goes LOW, the last pair of I and Q values will be sampled and transferred to the baseband processor (both I and Q components). BIOCLK stops after additional 16 BIOCLK cycles. The receive path is powered down again. In power-down the BIOCLK output is put in 3-state and the BOEN output is HIGH.

The output format is 2 × 12-bit I/Q (twos complement). Transmission occurs MSB first, I followed by Q. The serial clock signal BIOCLK will run at 6.5 MHz, or 13 MHz in the NZIF mode. Figure 6 shows the timing of the BSI data reception.

An automatic offset compensation mechanism is provided in order to achieve the required performance. This mechanism will short the receive (RX) inputs internally and measure the resulting offset value. This offset value will be subtracted from all subsequent I/Q output words. The offset inherent to the device can thereby be reduced to a few millivolts. Default value for both I- and Q-offset is zero.

Baseband and audio interface for GSM

PCF50732

Offset compensation measurement can be done on three channels separately: baseband receive I channel, baseband receive Q channel and AUXADC channel. All AUXADC channels use the same offset compensation value. Starting an offset measurement is done by writing a logic 1 into the offset trigger register for each channel that needs calibration. If the value '7' (decimal) is written into the offset trigger register offsets will be measured for I, Q and AUXADC channels.

Offsets can also be read or written directly. Each offset measurement is implemented internally as an AUXADC measurement and takes approximately 100 μs. Offsets from -256 up to 255 can be compensated.

**Table 4** Connection of BSI receive signals to the PCF5087X

PCF50732		PCF5087X	
PIN	I/O	PIN	I/O
RXON	I	RFSIG[z]	O
BDIO	I/O	SIOXD	I/O
BOEN	O	SIXEN_N	I
BIOCLK	O	SIOXCLK	I

9.3.4 BASEBAND SERIAL INTERFACE (BSI) TIMING CHARACTERISTICS

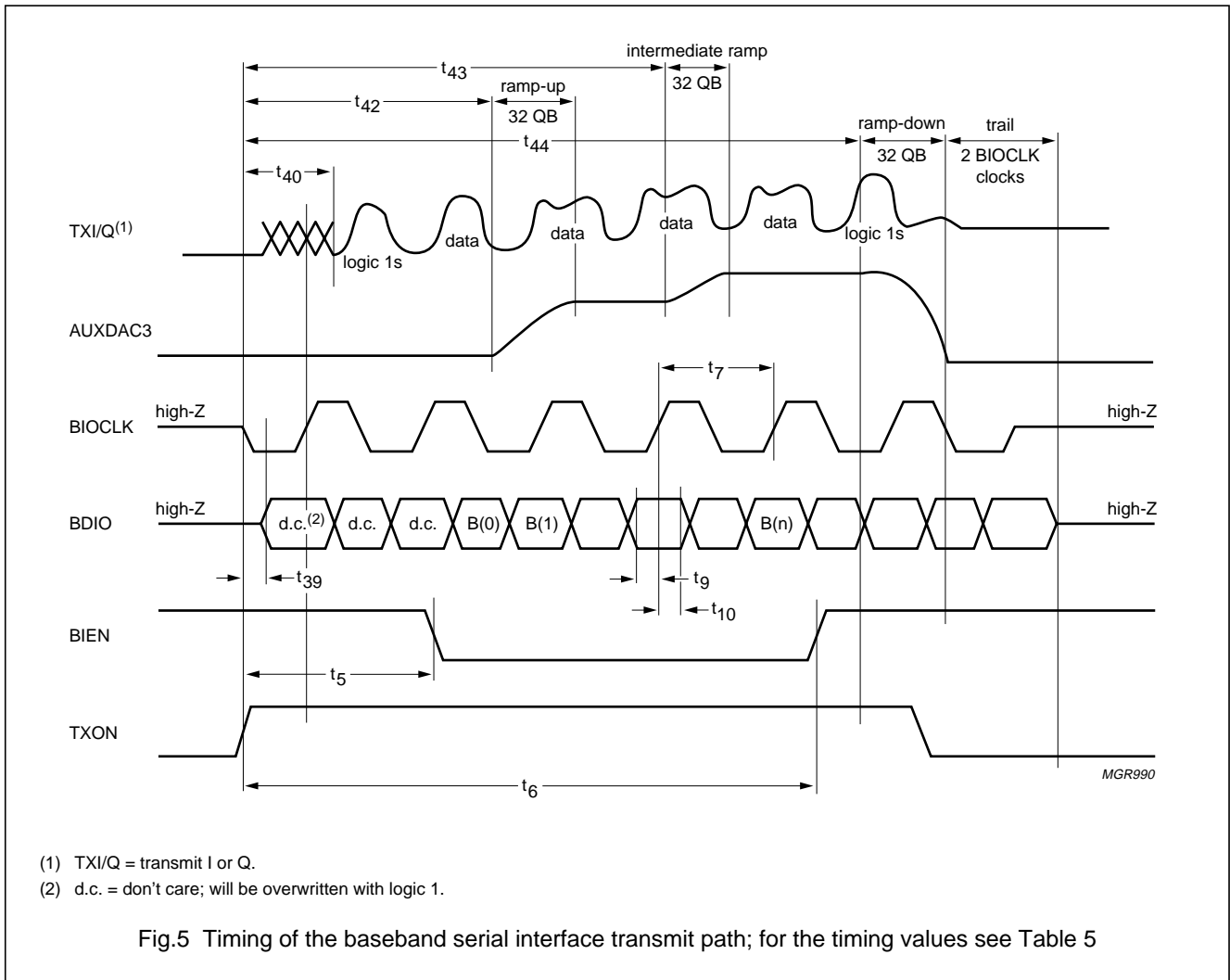

Baseband and audio interface for GSM

PCF50732

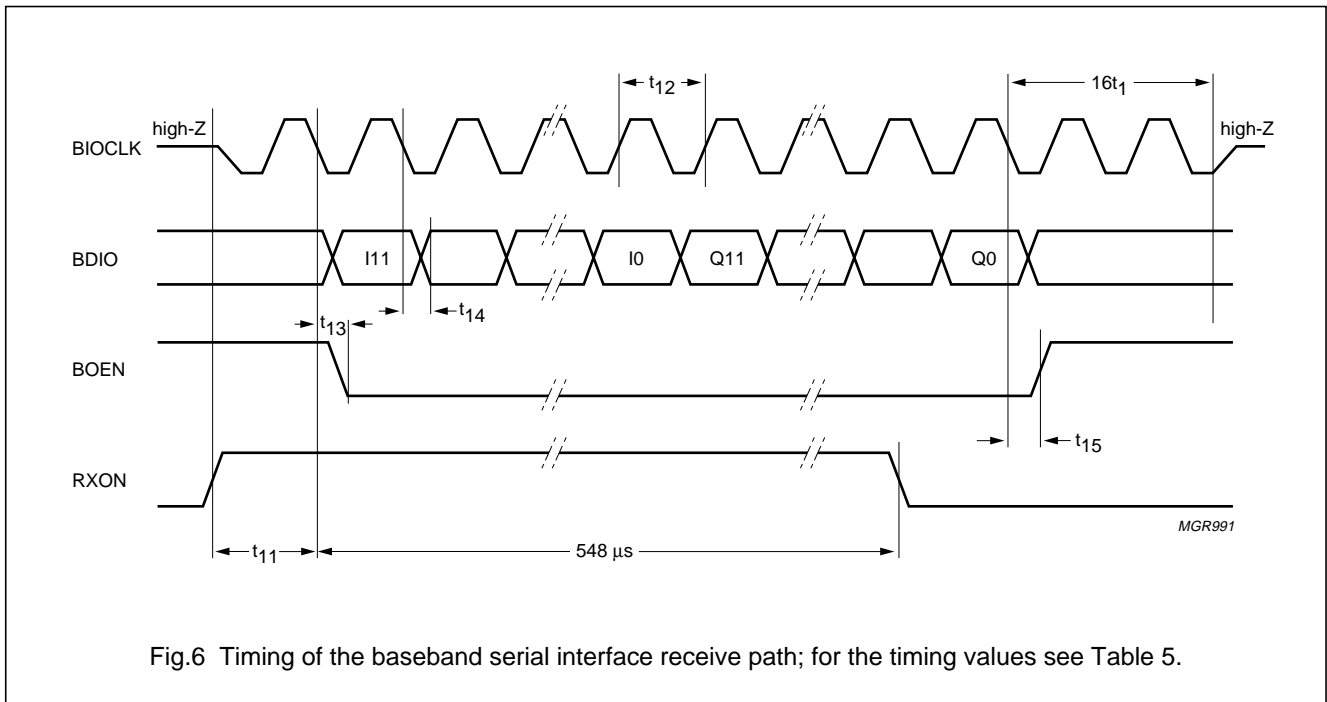

Table 5 BSI timing characteristics

SYMBOL	PARAMETER	MIN.	TYP.	MAX.	UNIT
<b>Master clock</b>					
$t_1$	MCLK cycle time	–	76.9	–	ns
$t_2$	MCLK LOW time	30	$\frac{1}{2}t_1$	–	ns
$t_3$	MCLK HIGH time	30	$\frac{1}{2}t_1$	–	ns
$t_4$	RESET LOW time	$3t_1$	–	–	ns
<b>Baseband Serial Interface (BSI) transmit path (see Fig.5)</b>					
$t_5$	BIEN0 value	10	–	511	QB
$t_6$	BIEN1 value	$t_5$	–	4000	QB
$t_7$	BIOCLK cycle time	–	$48t_1$	–	ns
$t_9$	data set-up time	20	–	–	ns
$t_{10}$	data hold time	20	–	–	ns
$t_{39}$	BIOCLK active after TXON rising edge	–	–	$t_1$	ns
$t_{40}$	analog TX and GMSK power-up time	–	–	17.4	QB
$t_{42}$	ramp-up value	0	–	3940	QB
$t_{43}$	intermediate ramp value	$32 + t_{42}$	–	3980	QB
$t_{44}$	ramp-down value				
	normal mode	$32 + t_{42}$	–	4020	QB
	double burst mode	$32 + t_{43}$	–	4020	QB

## Baseband and audio interface for GSM

## PCF50732

SYMBOL	PARAMETER	MIN.	TYP.	MAX.	UNIT
<b>Baseband Serial Interface (BSI) receive path</b> (see Fig.6)					
t <sub>11</sub>	analog power-up and filter settling time				
	ZIF mode	–	52	–	μs
	NZIF mode	–	26	–	μs
t <sub>12</sub>	BIOCLK cycle time				
	ZIF mode	–	2t <sub>1</sub>	–	ns
	NZIF mode	–	t <sub>1</sub>	–	ns
t <sub>13</sub>	BOEN LOW after falling clock edge	–	–	15	ns
t <sub>14</sub>	BIOCLK falling edge to data valid	–	–	15	ns
t <sub>15</sub>	BOEN HIGH after falling clock edge	–	–	15	ns

## 10 VOICE BAND CODEC

The voice band CODEC is a complete analog front-end circuit. It consists of three parts:

- The **receive path**, which converts a digital linear PCM signal to an analog signal for an earpiece, an external loudspeaker or a buzzer
- The **transmit path**, which receives an analog signal from a microphone or an auxiliary input and converts it into a digital linear PCM signal
- The digital **Audio Serial Interface (ASI)**, which connects the digital linear PCM signals of the receive and transmit paths to a digital signal processor.

Various functions and characteristics of the voice band CODEC can be selected by programming the corresponding control registers in the Control register block (see also Tables 11, 22, 23, 24 and 25).

### 10.1 Voice band receive path

The voice band receive path consists of the following parts:

- The receive part of the voice band signal processor
- **NOISE SHAPER**: 3rd order digital  $\Sigma\Delta$  modulator, generates a bit stream at 1 MHz to drive the EARDAC
- **EARDAC**: digital-to-analog converter including low-pass filter for high frequency noise content of noise shaper
- **EARAMP**: amplifier for an earpiece
- **AUXAMP**: amplifier for an auxiliary loudspeaker
- **BUZAMP**: amplifier for a buzzer output.

Linearity of receiver equipment (to earpiece) at EARPGA = 0 dB and a volume control (VOLPGA and EARAMP or AUXAMP) of –12 dB, signal-to-total harmonic distortion ratio according to “GSM recommendation II.11.10 V.4.16.1”.

#### 10.1.1 RXVOL

RXVOL controls the volume of the voice band receive path. In conjunction with EARAMP, AUXAMP and BUZAMP it allows a gain variation from +6 to –30 dB in 64 steps; see Table 25. RXVOL also provides a mute selection of the three outputs EARP/EARN, AUXSP and BUZ respectively. At RESET the volume is automatically set to –12 dB.

#### 10.1.2 RXPGA

RXPGA controls the gain of the voice band receive path within a range of –24 to +12 dB in 64 steps for calibration purposes.

#### 10.1.3 RXFILTER

RXFILTER is a digital band-pass filter with a pass band from 300 to 3400 Hz. It is realized by a programmable structure (voice band signal processor).

#### 10.1.4 EARDAC

EARDAC is a DAC operating at a sampling frequency of 1 MHz. It converts the bitstream input to a sampled differential analog signal and low-pass filters the output signal at the same time.



## Baseband and audio interface for GSM

## PCF50732

### 10.1.5 EARAMP

EARAMP is an amplifier, capable of driving a standard earpiece with a minimum impedance of 8  $\Omega$  in single-ended mode or 16  $\Omega$  in differential mode.

### 10.1.6 AUXAMP

AUXAMP is an amplifier for connection to an external loudspeaker amplifier of minimum 8  $\Omega$  (hands-free car kit).

An 'auxiliary speaker external amplifier control' output pin (AMPCTRL) can be used to switch on/off an external amplifier (hands-free car kit). The status of AMPCTRL is programmable via the Control Serial Interface; its default value is on.

### 10.1.7 BUZAMP

BUZAMP is an amplifier for connection to an external buzzer of minimum 8  $\Omega$ . It has the same output characteristics as the AUXAMP and can hence be used as a second auxiliary output amplifier. It is switched on/off by a dedicated control bit in the Control register block.

## 10.2 Voice band transmit path

The voice band transmit path consists of the following parts:

- **MICMUX**: microphone input multiplexer
- **MICADC**:  $\Sigma\Delta$  analog-to-digital converter
- **DECIMATOR**: decimates the incoming bit stream from 1 MHz to 40 kHz
- **TXFILTER**: band-pass filter for the digital transmit signal and down-sampling
- **TXPGA/LIM**: fine-programmable gain for calibration, limiter
- **SidePGA**: voice band sidetone programmable gain amplifier.

Linearity of transmitter equipment, signal-to-total harmonic distortion ratio according to "GSM recommendation II.11.10 V.4.16.1".

### 10.2.1 MICMUX

MICMUX is used to select between a differential signal at pins MICP/MICN and a differential signal at pins AUXMICP/AUXMICN.

Values are specified for a standard electret microphone with a sensitivity of  $-64 \pm 3$  dB for high gain or for an external microphone with an amplifier sensitivity of  $-26 \pm 3$  dB (0 dB  $\equiv$  1 V/0.1 Pa = 1 V/ $\mu$ bar; at 1 kHz).

### 10.2.2 MICADC

MICADC is a  $\Sigma\Delta$  A/D converter which generates a 1 MHz bitstream.

### 10.2.3 DECIMATOR AND TXFILTER

The DECIMATOR is a digital filter, which performs a signal processing to a lower sampling rate at the output compared to the input.

The bitstream with a sampling frequency of 1 MHz is low-pass filtered and down-sampled to 40 kHz by a FIR filter.

A digital high-pass filter and a digital low-pass filter (both IIR filters) process the 14-bit input samples to achieve a band-pass with a pass band from 300 to 3400 Hz. These filters run on the on-chip voice band signal processor (see Fig.7). It's program is down-loaded into the instruction memory (IRAM) via the CSI (see Table 26).

The output of the TXFILTER is down-sampled to a sampling frequency of 8 kHz with a word length of 16 bits.

### 10.2.4 TXPGA

TXPGA adapts the analog signals coming from MICMUX within a range of  $-30$  to  $+6$  dB. It is designed for calibration purposes.

### 10.2.5 SidePGA

SidePGA loops part of the voice band transmit signal back into the receive path. There are 64 gain steps from mute to  $+6$  dB.

## 10.3 Voice band digital circuitry

The voice band digital circuitry is responsible for converting a 16-bit PCM signal at 8 kHz sample rate to and from a 1-bit 1 MHz signal. It also contains a band-pass filter for 300 to 3400 Hz and a sidetone engine. Various volume settings are calculated inside this block. Figure 7 shows the block diagram of the voice band signal processor.

Baseband and audio interface for GSM

PCF50732

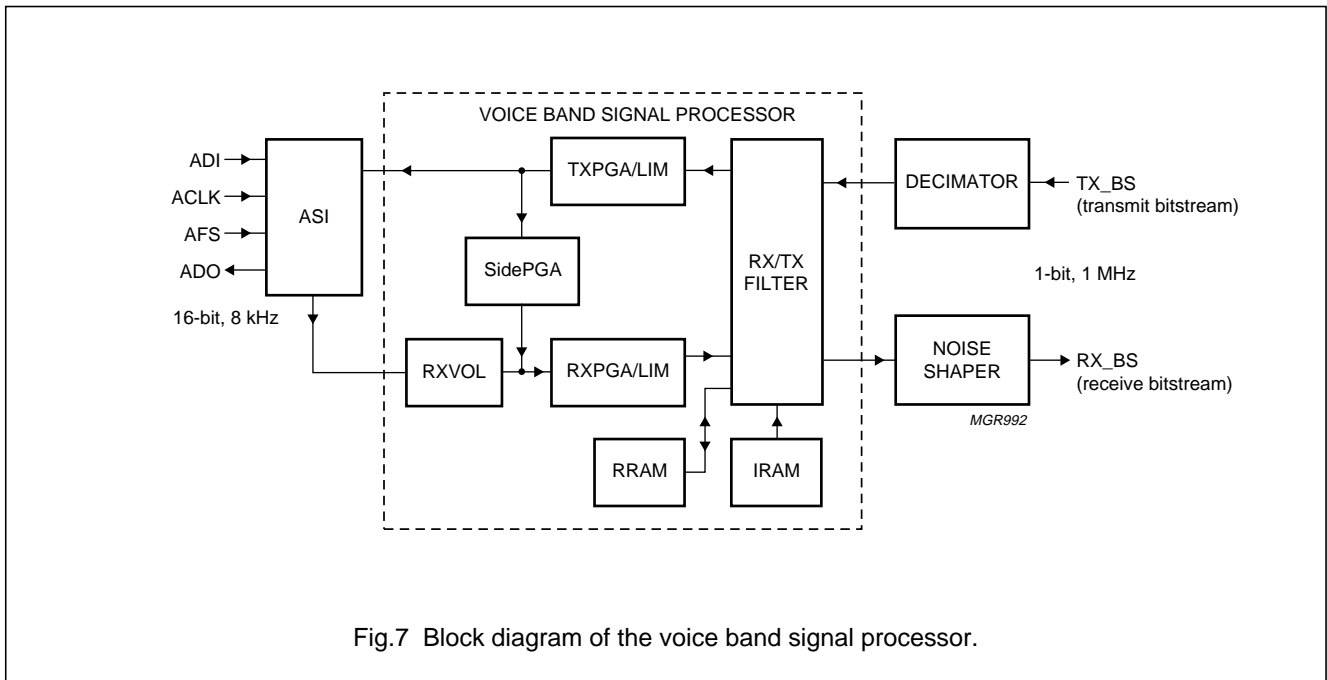

Fig.7 Block diagram of the voice band signal processor.

10.3.1 VOLUME CONTROL BLOCK

The volume control block contains the RXPGA, SidePGA, TXPGA and both limiter blocks. The possible settings can be found in the description of the CSI block. All digital volume control blocks, i.e. RXPGA, SidePGA, and TXPGA, will allow settings from +6 to -30 dB and mute in 64 steps. However, not all combinations of settings for these blocks will be meaningful. The limiter will always clip signals with overflow to the maximum or minimum allowable value.

10.3.2 AUDIO SERIAL INTERFACE (ASI) BLOCK

The ASI is the voice band serial interface which provides the connection for the exchange of PCM data in both receive and transmit directions, between the baseband digital signal processor and the PCF50732. The data is coded in 16-bit linear PCM twos complement words.

A frame start is defined by the first falling edge of ACLK after a rising AFS. This first falling edge is used to clock in the first data bit on both the baseband and the DSP device.

Data on pin ADI is clocked in (MSB first) on the falling edge of the ACLK clock. Data is clocked out (MSB first) on pin ADO on the rising edge of the ACLK clock.

Pin ADO is put in 3-state after the LSB of the transmit word, independent of the length of the AFS pulse. If the channel position 0 (see Section 10.3.2.1) is selected, then the MSB must be output directly after AFS becomes a logic 1, even if no rising edge on ACLK has been given yet.

The following modes of operation are programmable: channel position and ACLK clock mode.

10.3.2.1 Channel position mode

Depending on a programmable register value n (n = 0 to 15) one of 16 channels can be selected (see Table 22). The ASI can add a delay of 16 × n-bit clocks between the assertion of AFS and the start of the MSB of the PCM values. This delay is independently programmable for transmit and receive mode.

10.3.2.2 ACLK clock mode

Single or double clock mode can be selected. Double clock mode implies two clock pulses per data bit and is used for communication with IOM2 compatible devices. In double clock mode data must be output on the first rising edge and be read on the last falling edge.

Baseband and audio interface for GSM

PCF50732

**Table 6** Pin connection of the audio serial interface to the PCF5087X

PCF50732		PCF5087X	
PIN	I/O	PIN	I/O
ADI	I	DD	O
ADO	O	DU	I
ACLK	I	DCL	O
AFS	I	FSC	O

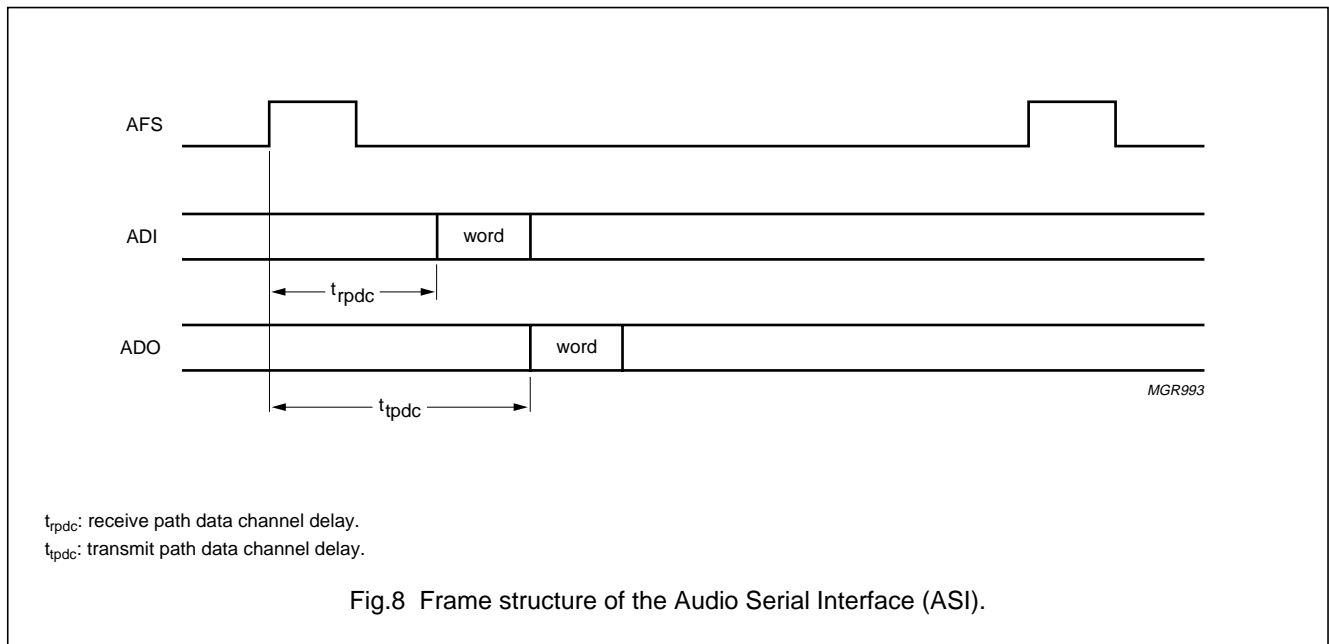

Baseband and audio interface for GSM

PCF50732

10.3.2.3 Audio Serial Interface (ASI) timing characteristics

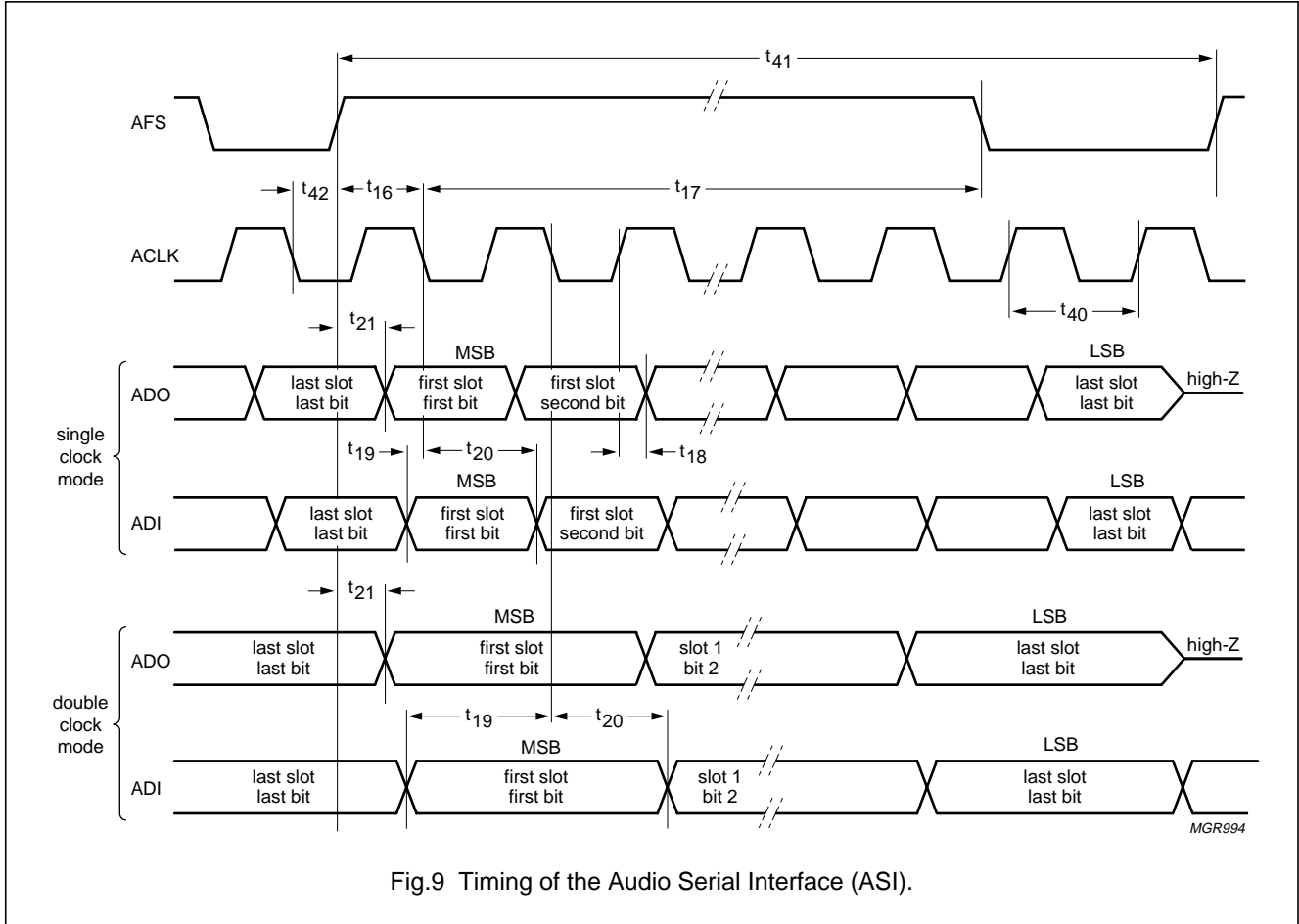

Fig.9 Timing of the Audio Serial Interface (ASI).

Table 7 ASI timing characteristics

SYMBOL	PARAMETER	MIN.	TYP.	MAX.	UNIT
$t_{16}$	frame sync (AFS) set-up time to falling edge of ACLK	70	–	–	ns
$t_{17}$	frame sync (AFS) hold time from falling edge of ACLK	40	–	–	ns
$t_{18}$	ACLK rising edge to data (ADO) valid	–30	–	+30	ns
$t_{19}$	data (ADI) set-up time to falling edge of ACLK	50	–	–	ns
$t_{20}$	data (ADI) hold time from falling edge of ACLK	80	–	–	ns
$t_{21}$	first data valid (ADO) after AFS rising edge	0	–	60	ns
$t_{40}$	ACLK period				
	single clock mode	0.5	–	7.8	$\mu$ s
	double clock mode	0.5	–	3.9	$\mu$ s
$t_{41}$	AFS period	–	125	–	$\mu$ s
$t_{42}$	ACLK LOW before AFS rising edge	40	–	–	ns

## Baseband and audio interface for GSM

## PCF50732

### 11 AUXILIARY FUNCTIONS

The auxiliary functions part consists of three digital-to-analog converters (DACs) and a 4 input analog-to-digital converter (ADC) with a 12-bit range. The DACs are for:

- Automatic Gain Control (AGC): AUXDAC1
- Automatic Frequency Control (AFC): AUXDAC2
- Power ramping: AUXDAC3.

#### 11.1 Automatic Gain Control (AGC): AUXDAC1

The AUXDAC1 is an 8-bit binary coded, guaranteed monotonic digital-to-analog converter.

The status of AUXDAC1 is controlled by the signal AUXST and a power-up bit in the Power control register. The signal that switches the external VCXO can also be used to control the AUXST pin of the PCF50732. The AUXDAC1 output is floating in Power-down mode (AUXST = LOW). The input MCLK is then deactivated.

When AUXST goes HIGH, AUXDAC1 is powered-up and the converted value of the corresponding register in the control register block is available at the AUXDAC1 output pin.

If a write access to the AUXDAC1 register occurs, the DAC is activated with the new content of the DAC register (see Table 14 and 15). The AUXDAC1 must be powered-up by setting the correct bit in the Power control register. At reset AUXDAC1 is powered-down.

#### 11.2 Automatic Frequency Control (AFC): AUXDAC2

The AUXDAC2 is a 12-bit binary coded, guaranteed monotonic digital-to-analog converter. This DAC is used to control the frequency of an external master clock VCXO.

The status of AUXDAC2 is controlled by the signal AUXST and a power-up bit in the Power control register. The signal that switches the external VCXO can also be used to control the AUXST pin of the PCF50732. The AUXDAC2 output is floating in Power-down mode (AUXST = LOW). When AUXST goes HIGH, AUXDAC2 is powered-up and the converted value of the corresponding register in the control register block is available at the AUXDAC2 output pin.

The default value for AUXDAC2 is 1.1 V which corresponds to a 800H code in the AUXDAC2 register. At reset AUXDAC2 is powered on.

#### 11.3 Power ramping: AUXDAC3

AUXDAC3 is a 10-bit binary coded digital-to-analog converter designed for power ramping purposes. AUXDAC3 is default off. The power ramping behaviour is described in Section 9.3.2.2.

#### 11.4 Auxiliary analog-to-digital converter (AUXADC)

The AUXADC is specified for voltage and temperature measurements. It contains 4 input channels required for  $\Delta T$  and  $\Delta V$  measurements, as well as battery type recognition:

- $\Delta T$ : battery temperature, ambient temperature (measured across sensor)
- $\Delta V$ : peak battery voltage, battery voltage during transmit burst.

Five 12-bit registers are available in which results of auxiliary analog-to-digital conversions can be stored. Two registers are dedicated to the input AUXADC1 and one to each of AUXADC2, AUXADC3 and AUXADC4.

The AUXADC1 input can be used for battery voltage measurement. In the AUXADC1A register the voltage during a transmit time slot can be stored. The AUXADC1B register can store the voltage during other time slots. If a read request to one of these registers is executed by loading its address into the Read request register, the actual contents of the addressed register are given to the control interface and a new measurement is performed in the next appropriate time slot.

A multiplexer connects each of the AUXADC inputs to a channel of the receive ADC depending on read access to the corresponding register.

Thus an auxiliary analog-to-digital conversion is only possible, if the baseband receive section is not in use (RXON is LOW). At each read request to one of the AUXADC registers, a flag is set in the AUXADC flag register indicating that an analog-to-digital conversion is to be performed. When one of the registers AUXADC1B, AUXADC2, AUXADC3, or AUXADC4 is being read, the baseband interface verifies that RXON is LOW, indicating that no receive burst is currently active. The baseband receive path is then powered up. After the ADC settling time has elapsed (see  $POST_{AUXADC}$  in Chapter 18), valid data is available and stored in the corresponding register.

Baseband and audio interface for GSM

PCF50732

After conversion the corresponding bit in the AUXADC flag register is reset (see Table 18). If RXON is activated during an auxiliary analog-to-digital conversion cycle, the auxiliary conversion is interrupted and restarted when RXON returns LOW, indicating no receive burst activity.

The PCF50732 waits for a rising edge of TXON, and powers up the receive path. After the settling time of the ADC added to the programmed AUXADC conversion delay (in 48 MCLK cycles) has elapsed, valid data is available and stored in the AUXADC1A register.

When register AUXADC1A is read, a battery voltage measurement during a transmission burst is executed.

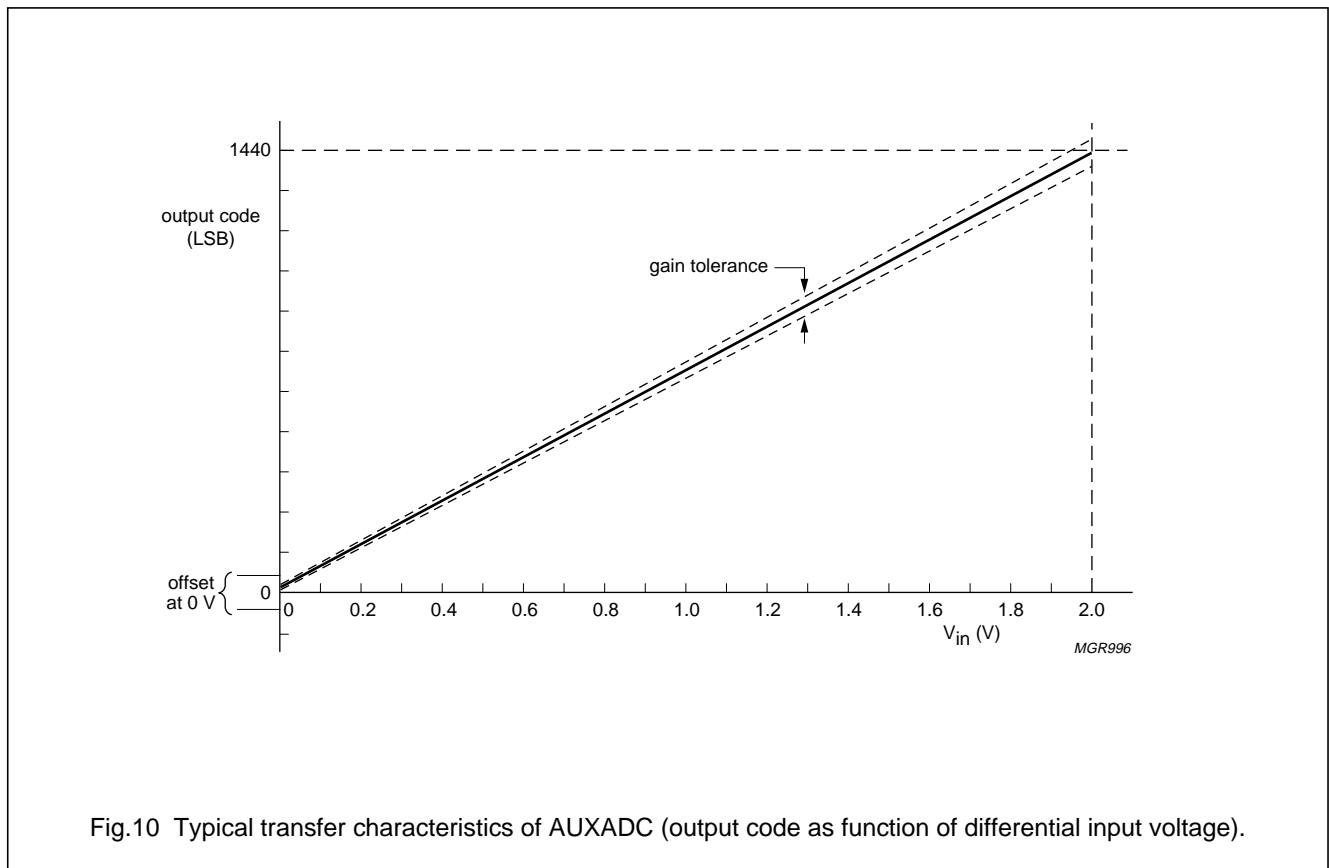

Fig.10 Typical transfer characteristics of AUXADC (output code as function of differential input voltage).

## Baseband and audio interface for GSM

## PCF50732

**12 CONTROL SERIAL INTERFACE (CSI)**

The Control Serial Interface block is used to set and read the status bits inside the PCF50732. It is also used to read data from the auxiliary ADCs and to write data into the auxiliary DACs. Finally, the block is used to write the power ramping curve into a  $64 \times 10$ -bit static RAM. It should be noted that only 48 of the 64 addresses can be accessed; see Table 2.

**12.1 The serial interface**

A 4-line bidirectional serial interface is used to control the circuit. It allows access to each register of the control register block (read and/or write). The 4 lines are:

- Data in (CDI)
- Data out (CDO)
- Clock (CCLK)
- Enable (CEN).

Table 8 lists the normal connections to the PCF5087X.

The data sent to or from the device is loaded in bursts framed by CEN. Clock edges and data bits are ignored until CEN goes active (LOW). Each data word consists of 21 bits that comprises a 4-bit device address, a 4-bit register address, a 12-bit data word and a dummy bit; see Table 9. The 21 bits are transmitted with MSB first.

Figure 5 shows the valid timing for data transmission on the control interface.

Data is read in from the CDI pin on the rising edge of the CCLK clock and output on CDO on the falling edge of the CCLK clock. Data is written into the registers on the rising edge of CEN.

If the device address is equal to the chip address, the programmed information on CDI (DB11 to DB00) is loaded into the addressed register (RA3 to RA0) when CEN returns inactive HIGH.

The dummy bit in front is needed for compatibility with older baseband devices.

Reading a register is accomplished by writing the address of the required register into the read request register. The next time CEN goes LOW, the requested data will be shifted out, together with the register and device address.

**Table 8** Pin connection of the CSI to the PCF5087X

PCF50732		PCF5087X	
PIN	I/O	PIN	I/O
CDI	I	RFDO	O
CDO	O	RFDI	I
CCLK	I	RFCLK	O
CEN	I	RFE_N2	O

**Table 9** Bit mapping of the 21-bit words

BIT	CONTENT	DESCRIPTION
00 to 03	ADD0 to ADD3	device address; for the PCF50732 this is '1001' (= 9 decimal)
04 to 07	RA0 to RA3	register address
08 to 19	DB00 to DB11	data value
20	dummy	don't care

Baseband and audio interface for GSM

PCF50732

12.2 Control Serial Interface (CSI) timing characteristics

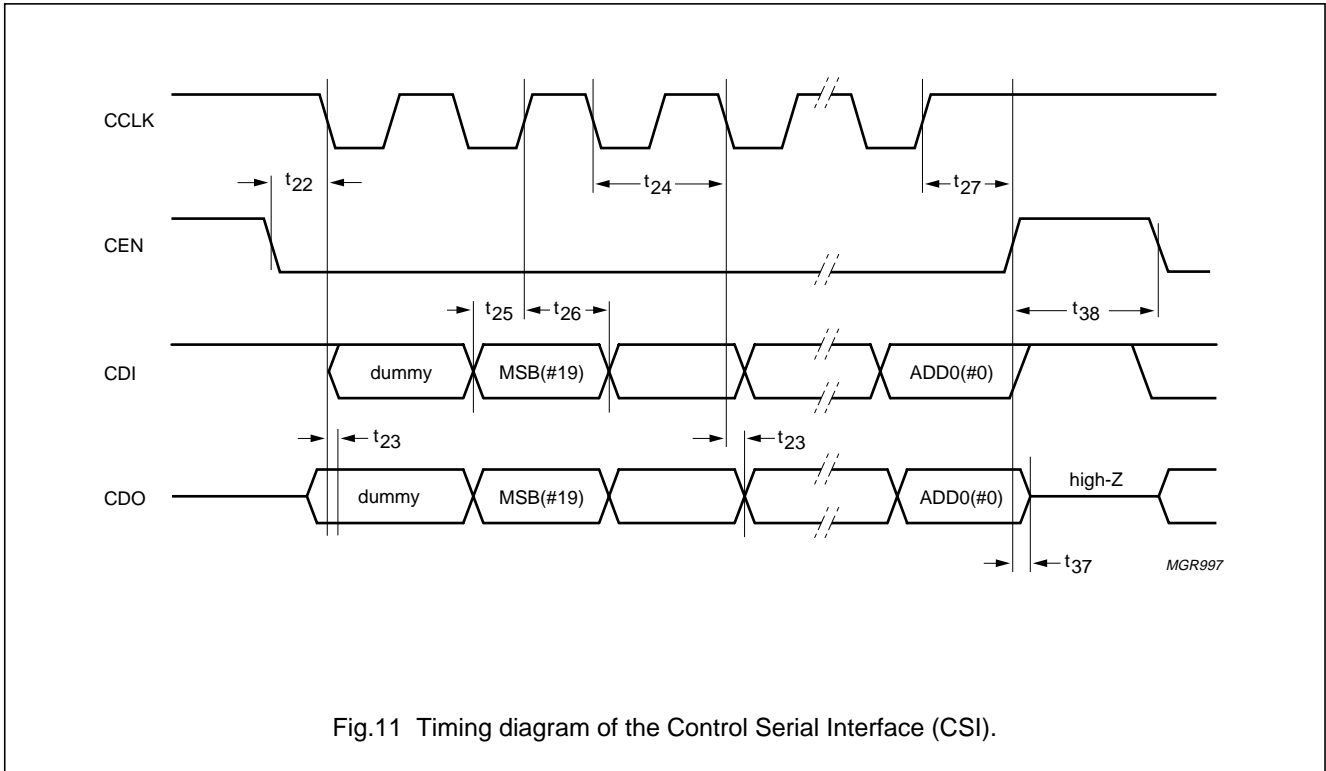

Fig.11 Timing diagram of the Control Serial Interface (CSI).

Table 10 CSI timing characteristics

For the timing diagram see Fig.11.

SYMBOL	PARAMETER	MIN.	MAX.	UNIT
$t_{22}$	CEN set-up time	20	–	ns
$t_{23}$	CDO data valid after falling clock edge	–	50	ns
$t_{24}$	CCLK cycle time	100	–	ns
$t_{25}$	data set-up time to rising edge of CCLK	20	–	ns
$t_{26}$	data hold time from rising edge of CCLK	30	–	ns
$t_{27}$	CEN hold time	30	–	ns
$t_{37}$	CDO 3-state after CEN HIGH	–	30	ns
$t_{38}$	CEN HIGH time	50	–	ns



## Baseband and audio interface for GSM

## PCF50732

**12.3 Control register block**

This section describes the different registers that are implemented in the PCF50732. An overview is given in Table 11. Tables 12 to 29 describe all the registers of the PCF50732.

**Table 11** Control register block overview

ADDRESS	ACCESS	REGISTER NAME
0000	W	Read request register
0001	R/W	AUXDAC1 (AGC) value register
0010	R/W	AUXDAC2 (AFC) value register
0011	R/W	Burst control register
0100	R/W	AUXADC control register
0101	R	AUXADC channel 1 register A (AUXADC1A); note 1
0110	R	AUXADC channel 1 register B (AUXADC1B); note 1
0111	R	AUXADC channel 2 register (AUXADC2); note 1
1000	R	AUXADC channel 3 register (AUXADC3); note 1
1001	R	AUXADC channel 4 register (AUXADC4); note 1
1010	R/W	Voice band control register
1011	R/W	Voice band volume register
1100	R/W	Power control register
1101	R/W	RAM interface register
1110	R/W	Baseband receive control register
1111	R/W	Test mode register; note 2

**Notes**

1. See description in Section 11.4.
2. Do not use this register.

## 12.3.1 READ REQUEST REGISTER

**Table 12** Read request register

X = don't care during a read/or write access.

ADDRESS	REGISTER NAME	VALUE											
		11	10	9	8	7	6	5	4	3	2	1	0
0000	Read request register	X	X	X	X	r3	r2	r1	r0	s3	s2	s1	s0

**Table 13** Read request registers value description

VALUE OF	SYMBOL	DESCRIPTION
Read request register	r3 to r0	Address of the register to be read.
	s3 to s0	Subaddress that might be needed. The subaddress bits are right aligned, meaning that the subaddress always starts with bit 's0' (LSB); e.g. in case of two subaddress bits, 's1' and 's0' are used.

## Baseband and audio interface for GSM

## PCF50732

## 12.3.2 AUXDAC1 (AGC) VALUE AND AUXDAC2 (AFC) VALUE REGISTERS

**Table 14** Registers overview

X = don't care during a read/or write access.

ADDR.	REGISTER NAME	VALUE											
		11	10	9	8	7	6	5	4	3	2	1	0
0001	AUXDAC1 (AGC) value register	X	X	X	X	b7	b6	b5	b4	b3	b2	b1	b0
0010	AUXDAC2 (AFC) value register	b11	b10	b9	b8	b7	b6	b5	b4	b3	b2	b1	b0

**Table 15** AUXDAC1 (AGC) value and AUXDAC2 (AFC) value registers value description

VALUE OF	SYMBOL	DESCRIPTION
AUXDAC1 (AGC) value register	b7 to b0	input value to the 8-bit AUXDAC1 (fed directly into the DAC); the default value is 85H
AUXDAC2 (AFC) value register	b11 to b0	input value to the 8-bit AUXDAC2 (fed directly into the DAC); the default value is 800H

## 12.3.3 BURST CONTROL REGISTER

The Burst control register controls the timing of the transmit burst (TX-burst). The 'lo'-registers contain the lower 8 bits, the 'hi'-registers the upper 4 bits of a 12-bit delay value. Therefore, each register has a programmable range from 0 to 4095. Not all combinations of values might make sense e.g. ramp-down before ramp-up.

**Table 16** Burst control register (address 001 and subaddresses)

X = don't care during a read/or write access.

FUNCTION	SUBADDRESS				VALUE							
	11 (s3)	10 (s2)	9 (s1)	8 (s0)	7	6	5	4	3	2	1	0
RU-lo	0	0	0	0	b7	b6	b5	b4	b3	b2	b1	b0
RU-hi	0	0	0	1	X	X	X	X	b11	b10	b9	b8
RM-lo	0	0	1	0	b7	b6	b5	b4	b3	b2	b1	b0
RM-hi	0	0	1	1	X	X	X	X	b11	b10	b9	b8
RD-lo	0	1	0	0	b7	b6	b5	b4	b3	b2	b1	b0
RD-hi	0	1	0	1	X	X	X	X	b11	b10	b9	b8
BIEN0-lo	0	1	1	0	b7	b6	b5	b4	b3	b2	b1	b0
BIEN0-hi	0	1	1	1	X	X	X	X	b11	b10	b9	b8
BIEN1-lo	1	0	0	0	b7	b6	b5	b4	b3	b2	b1	b0
BIEN1-hi	1	0	0	1	X	X	X	X	b11	b10	b9	b8
Single/double burst mode <sup>(1)</sup>	1	0	1	0	X	X	X	X	X	X	X	b0
DAC3 burst RAM address <sup>(1)</sup>	1	0	1	1	X	X	a5	a4	a3	a2	a1	a0
DAC3 burst RAM data <sup>(1)</sup>	1	1	d9 <sup>(2)</sup>	d8 <sup>(2)</sup>	d7	d6	d5	d4	d3	d2	d1	d0

**Notes**

1. The programming is described in Section 9.3.2.2.
2. The subaddress positions bit 9 (s1) and bit 8 (s0) do not apply to the DAC3 burst RAM data register.

## Baseband and audio interface for GSM

PCF50732

**Table 17** Burst control registers value description

VALUE OF	DESCRIPTION
RU	Value RU, consisting of RU-lo (least significant byte) and RU-hi (most significant byte), is the delay measured in quarterbits ( $\frac{1}{12}$ MCLK) between the rising edge of TXON and the start of the ramp-up on AUXDAC3. After this delay, the first 16 values of the AUXDAC3 RAM are sent to AUXDAC3. Shifting out is done at $\frac{1}{24}$ MCLK.
RM	Value RM, consisting of RM-lo (least significant byte) and RM-hi (most significant byte), is the delay measured in quarterbits between the rising edge of TXON and the start of the intermediate ramp in a double burst ramp. The RM value is only used in multislot mode. RM must be greater than RU + 32.
RD	Value RD, consisting of RD-lo (least significant byte) and RD-hi (most significant byte), is the delay measured in quarterbits between the rising edge of TXON and the start of the ramp-down on AUXDAC3. RD must be greater than RU + 32, or in case of multislot mode, greater than RM + 32.
BIEN0	Value BIEN0, consisting of BIEN0-lo (least significant byte) and BIEN0-hi (most significant byte), is the delay measured in quarterbits between the rising edge of TXON and the falling edge of BIEN.
BIEN1	Value BIEN1, consisting of BIEN1-lo (least significant byte) and BIEN1-hi (most significant byte), is the delay measured in quarterbits between the rising edge of TXON and the rising edge of BIEN. BIEN1 must be greater than BIEN0.

## 12.3.4 AUXADC CONTROL REGISTER

**Table 18** AUXADC control register (address 0100 and subaddresses)

X = don't care during a read/or write access.

FUNCTION	SUBADDRESS			VALUE								
	11 (s2)	10 (s1)	9 (s0)	8	7	6	5	4	3	2	1	0
AUXADC conversion delay value register	0	0	0	X	X	b6	b5	b4	b3	b2	b1	b0
AUXADC flag register	0	0	1	X	Qoff	loff	auxoff	flag 4	flag 3	flag 2	flag 1B	flag 1A
AUXADC offset value register	1	0	0	9-bit signed offset compensation value								
I channel offset value register	1	0	1	9-bit signed offset compensation value								
Q channel offset value register	1	1	0	9-bit signed offset compensation value								
Offset trigger register	1	1	1	X	X	X	X	X	X	Q-off	I-off	Aux

## Baseband and audio interface for GSM

## PCF50732

**Table 19** AUXADC control registers value description

VALUE OF	DESCRIPTION
AUXADC conversion delay value register	The 7-bit value (b6 to b0) denotes the delay measured in 48MCLK units between the rising edge of TXON and the conversion on AUXADC1A. The normal power-on settling time is added to this delay. Default value is 0.
AUXADC flag register	The AUXADC flag register returns the status of the AUXADC converters. If an auxiliary A/D conversion is pending, the flag of the corresponding AUXADC will be set. The flag register is read only.
AUXADC offset value register	<p>The offset value registers contain signed 9-bit offset compensation values. These values are subtracted automatically from all baseband receive (BBRX) and AUXADC measurements to compensate for offset errors. The compensation values can be read and written and have a default value of 0. It can also be measured by the device itself.</p> <p>A write to the Offset trigger register will trigger an offset measurement for each of the channels (Q-off, I-off or AUXADC) selected.</p> <p>Offset measurements are special cases of AUXADC measurements and are done sequentially. Each calibration measurement takes approximately 100 <math>\mu</math>s. The Offset trigger register is write only.</p>
I channel offset value register	
Q channel offset value register	
Offset trigger register	

## 12.3.5 AUXADC REGISTERS

**Table 20** AUXADC registers overview

ADDR.	REGISTER NAME	VALUE											
		11	10	9	8	7	6	5	4	3	2	1	0
0101	AUXADC channel 1 register A (AUXADC1A)	b11	b10	b9	b8	b7	b6	b5	b4	b3	b2	b1	b0
0110	AUXADC channel 1 register B (AUXADC1B)												
0111	AUXADC channel 2 register (AUXADC2)												
1000	AUXADC channel 3 register (AUXADC3)												
1001	AUXADC channel 4 register (AUXADC4)												

**Table 21** AUXADC registers value description

VALUE OF	DESCRIPTION
AUXADC1A	12-bit result of the A/D conversion on AUXADC channel 1, measured during a transmission burst
AUXADC1B	12-bit result of the A/D conversion on AUXADC channel 1, measured outside a transmission burst
AUXADC2	12-bit result of the A/D conversion on AUXADC channel 2
AUXADC3	12-bit result of the A/D conversion on AUXADC channel 3
AUXADC4	12-bit result of the A/D conversion on AUXADC channel 4

Baseband and audio interface for GSM

PCF50732

12.3.6 VOICE BAND CONTROL REGISTER

The Voice band control register is used to control the following functionality of the voice band CODEC:

- Analog input source: microphone (MICAMP) or auxiliary (AUXMIC) input
- Analog output device: earphone (EARAMP), auxiliary (AUXAMP) or buzzer (BUZAMP) output; this register allows individual control of all three output amplifiers
- EARAMP output mode: single-ended (EARP) or differential (EARN/EARP). This selects the input source for the EARAMP-N amplifier. In single-ended mode EARAMP-N will be at  $V_{ref}$ , in differential mode it will carry the output signal
- General purpose output pin: AMPCTRL
- Receive and transmit path delay values
- ASI clock mode
- TX gain boost (MICH1).

**Table 22** Voice band control register (address 1010 and subaddresses)

X = don't care during a read/or write access.

FUNCTION	SUBADDRESS			VALUE								FUNCTION SETTING				
	11 (s2)	10 (s1)	9 (s0)	8	7	6	5	4	3	2	1		0			
Select input source	0	0	0	don't care								0	MICAMP (default)			
												1	AUXMIC			
Select output amplifier	0	0	1	don't care								X	X	X	0	EARAMP-P off
												X	X	X	1	EARAMP-P on (default)
												X	X	0	X	EARAMP-N off
												X	X	1	X	EARAMP-N on (default)
												X	0	X	X	AUXAMP off (default)
												X	1	X	X	AUXAMP on
												0	X	X	X	BUZAMP off (default)
												1	X	X	X	BUZAMP on
EARAMP output mode	0	1	0	don't care								0	single-ended			
												1	differential (default)			
AMPCTRL pin polarity	0	1	1	don't care								0	active LOW			
												1	active HIGH (default)			
Receive path data channel	1	0	0	don't care				d	c	b	a	4-bit delay value (default = 0)				
Transmit path data channel	1	0	1					d	c	b	a					
ASI clock mode	1	1	0	don't care								0	single clock (default)			
												1	double clock			
TX gain boost (MICH1)	1	1	1	don't care								0	7 dB			
												1	35 dB (default)			

## Baseband and audio interface for GSM

## PCF50732

## 12.3.7 VOICE BAND VOLUME REGISTER

Voice band gain settings can be independently programmed for: TXPGA, RXPGA, RXVOL and SidePGA.

**Table 23** Voice band volume register (address 1011 and subaddresses)

X = don't care during a read/or write access.

FUNCTION	SUBADDRESS			VALUE									SELECTED RANGE	DEFAULT SETTING
	11 (s2)	10 (s1)	9 (s0)	8	7	6	5	4	3	2	1	0		
TXPGA gain	0	0	0	X	X	X	a	b	c	d	e	f	-24 to +12 dB	0 dB
RXPGA gain	0	0	1	X	X	X	a	b	c	d	e	f		
RXVOL gain	0	1	0	X	X	X	a	b	c	d	e	f	-30 to +6 dB	-12 dB
SidePGA gain	0	1	1	X	X	X	a	b	c	d	e	f		mute
Band gap setting level	1	0	0	X	X	X	a	b	c	X	X	X	-100 to +75 mV	0 mV offset
Experimental bits	1	0	1	X	X	X	dir	pll	dc	vbch	hclk	bgb	-	pll on, all others off

**Table 24** Voice band volume registers value description

VALUE	REMARKS	DESCRIPTION
TXPGA gain	microphone calibration	TXPGA and RXPGA settings use the 6-bit binary fixed point value 'ab.cdef' as a multiplier for each PCM-sample. This results in a control range of +12 to -24 dB. See note 1a.
RXPGA gain	earphone calibration	
RXVOL gain	customer volume control	RXVOL and SidePGA settings use the 6-bit binary fixed point value 'a.bcdef' as a multiplier for each PCM-sample. This results in a control range of +6 to -30 dB (and mute). See note 1b.
SidePGA gain	-	
Experimental bits	-	<ul style="list-style-type: none"> <li>• dir: bypass clock buffer</li> <li>• pll: clock optimizer</li> <li>• dc: bypass clock capacitor</li> <li>• vbch: voice band chopping</li> <li>• hclk: 26 MHz master clock input</li> <li>• bgb: band gap boost</li> </ul>
Band gap setting level	<b>do not use</b>	

**Note**

- Possible gain settings are listed in Table 25 or can be calculated using the following formulae ('n' is an integer that represents the value that is written into the register; n = 0 to 63):

a) RXPGA and TXPGA:  $\text{gain} = 20 \times \log \frac{n}{16}$ ; add 6.02 dB to each gain for RXPGA and TXPGA settings.

b) RXVOL and SidePGA:  $\text{gain} = 20 \times \log \frac{n}{32}$

## Baseband and audio interface for GSM

## PCF50732

## 12.3.7.1 Possible gain selections for voice band blocks: RXPGA, TXPGA, RXVOL and SidePGA

Table 25 shows the possible gain selections for the voice band blocks RXPGA, TXPGA, RXVOL and SidePGA. It should be noted that not all possible combinations of these volume settings are meaningful; setting RXPGA, SidePGA and RXVOL to maximum will result in clipping of the output signal.

**Table 25** Gain selections

BINARY CODE	GAIN (dB)		BINARY CODE	GAIN (dB)	
	RXPGA/TXPGA	RXVOL/SidePGA		RXPGA/TXPGA	RXVOL/SidePGA
111111	11.88	5.88	011111	5.72	-0.28
111110	11.74	5.74	011110	5.44	-0.56
111101	11.60	5.60	011101	5.14	-0.86
111100	11.46	5.46	011100	4.84	-1.16
111011	11.31	5.31	011011	4.52	-1.48
111010	11.17	5.17	011010	4.20	-1.80
111001	11.01	5.01	011001	3.86	-2.14
111000	10.86	4.86	011000	3.50	-2.50
110111	10.70	4.70	010111	3.13	-2.87
110110	10.54	4.54	010110	2.75	-3.25
110101	10.38	4.38	010101	2.34	-3.66
110100	10.22	4.22	010100	1.92	-4.08
110011	10.05	4.05	010011	1.47	-4.53
110010	9.88	3.88	010010	1.00	-5.00
110001	9.70	3.70	010001	0.51	-5.49
110000	9.52	3.52	010000	0.00	-6.02
101111	9.34	3.34	001111	-0.58	-6.58
101110	9.15	3.15	001110	-1.18	-7.18
101101	8.96	2.96	001101	-1.82	-7.82
101100	8.77	2.77	001100	-2.52	-8.52
101011	8.57	2.57	001011	-3.28	-9.28
101010	8.36	2.36	001010	-4.10	-10.10
101001	8.15	2.15	001001	-5.02	-11.02
101000	7.94	1.94	001000	-6.04	-12.04
100111	7.72	1.72	000111	-7.20	-13.20
100110	7.49	1.49	000110	-8.54	-14.54
100101	7.26	1.26	000101	-10.12	-16.12
100100	7.02	1.02	000100	-12.06	-18.06
100011	6.78	0.78	000011	-14.56	-20.56
100010	6.53	0.53	000010	-18.08	-24.08
100001	6.27	0.27	000001	-24.10	-30.10
100000	6.00	0.00	000000	off	off

Baseband and audio interface for GSM

PCF50732

12.3.8 POWER CONTROL REGISTER

The Power control register is used to control power-up and power-down of the different sections of the device. Changing the power status is accomplished by addressing the device as shown in Table 26 and setting bit 0 (= a) according to the required state:

a = 0 → power-down

a = 1 → power-up.

Setting the baseband RX or TX flag is functionally equivalent to setting RXON or TXON respectively (logical OR function). The CSI is also accessible when the band gap is powered down. Therefore no reset is required to power-up after total power-down.

**Table 26** Power control register (address 1100 and subaddresses)

FUNCTION	SUBADDRESS				VALUE								DEFAULT		
	11 (s3)	10 (s2)	9 (s1)	8 (s0)	7	6	5	4	3	2	1	0	VALUE	STATUS	
AUXDAC1	0	0	0	1	don't care								a	0	off
AUXDAC2	0	0	1	0									a	1	on
AUXDAC3	0	0	1	1									a	0	off
Voice band transmit	0	1	0	0									a	0	off
Voice band receive	0	1	0	1									a	0	off
V <sub>ref</sub>	0	1	1	0									a	1	on
Baseband receive	1	0	0	0									a	0	off
Baseband transmit	1	0	0	1									a	0	off
Complete device	1	1	1	1									a	1	on

12.3.9 RAM INTERFACE REGISTER

The RAM interface register is a general purpose communication channel between the serial interface CSI and the voice band signal processor. None of the processor registers have default values.

The Voice band control register is used to communicate with the voice band signal processor. Register functions with subaddress '00' to '11' can be used to program the Instruction RAM (IRAM) when the voice band processor is not running, i.e. when voice band receive and transmit sections are both powered down.

The IRAM registers are used to write into the voice band instruction RAM.

Normal operation is to write an address into the VSP instruction RAM program counter and write low and high bytes of the 16-bit instructions into their respective locations. No auto-increment is foreseen, i.e. the address register must be updated by the user. Writing to the IRAM is only possible when voice band transmit and receive sections are both powered off. If this is not the case write actions are ignored.

Reading back from the IRAM is not straightforward due to the need for an extra clock pulse when accessing RAMs; when reading back the contents of RAM locations 1, 2, 3 and 4 actual output is 'undefined' as 1, 2, 3, etc.



## Baseband and audio interface for GSM

## PCF50732

**Table 27** RAM interface register (address 1101 and subaddresses)

X = don't care during a read/or write access.

FUNCTION	SUBADDRESS		VALUE									
	11 (s1)	10 (s0)	9	8	7	6	5	4	3	2	1	0
VSP instruction RAM data low-byte	0	0	X	X	d7	d6	d5	d4	d3	d2	d1	d0
VSP instruction RAM data high-byte	0	1	X	X	d7	d6	d5	d4	d3	d2	d1	d0
VSP instruction RAM program counter	1	0	X	a8	a7	a6	a5	a4	a3	a2	a1	a0
VSP interface register	1	1	x9	x8	x7	x6	x5	x4	x3	x2	x1	x0

## 12.3.10 BASEBAND RECEIVE CONTROL REGISTER

Normal bandwidth refers to an input signal bandwidth of 100 kHz used for ZIF operation, double bandwidth is 200 kHz used for NZIF operation. Normal sampling refers to a sampling rate of  $\frac{1}{2}$ MCLK, double sampling refers to sampling at MCLK.

**Table 28** Baseband receive control register (address 1110)

FUNCTION	VALUE											OUTPUT RATE	
	11	10	9	8	7	6	5	4	3	2	1		0
Normal bandwidth; normal sampling (ZIF) double sampling; note 2	0	0	don't care								0	0	271 kHz <sup>(1)</sup>
	0	0	don't care								0	1	135 kHz
Double bandwidth; normal sampling (NZIF) double sampling	0	0	don't care								1	0	542 kHz
	0	0	don't care								1	1	271 kHz

**Notes**

1. Default value.
2. Do not use this function.

## Baseband and audio interface for GSM

## PCF50732

## 12.3.11 TEST MODE REGISTER

Only test mode 8 (TM8) is available to the end user. It is used to mark baseband-I (BB-I) samples with a logic 0 and baseband-Q (BB-Q) samples with a logic 1 on the LSB of the 12-bit value.

**Table 29** Test mode register (address 1111)

TEST MODE	FUNCTION	VALUE											
		11	10	9	8	7	6	5	4	3	2	1	0
NM	normal mode (default)									0	0	0	0
TM1	baseband transmit (BBTX) I digital									0	0	0	1
TM2	baseband receive (BBRX) digital									0	0	1	0
TM3	voice band (VB) loop digital									0	0	1	1
TM4	voice band transmit/receive (VBTX/RX) digital									0	1	0	0
TM5	CSI									0	1	0	1
TM6	baseband (BB) DACs	don't care								0	1	1	0
TM7	voice band receive (VBRX) DAC current sources									0	1	1	1
TM8	I/Q marking test									1	0	0	0
TM9	voice band signal processor test mode									1	0	0	1
TM10	VSP signature output mode									1	0	1	0
TM11	MCLK input reflected on BDIO									1	0	1	1
TM12	baseband bitstream output									1	1	0	0

---

## Baseband and audio interface for GSM

## PCF50732

---

### 13 VOICE BAND SIGNAL PROCESSOR (VSP)

#### 13.1 Hardware description

The VSP used in the PCF50732 is a 30-bit fixed point VSP with separate data and instruction areas. The data path consists of two guard bits, 16 data bits before and 12 data bits behind the binary point for a total of 30 bits. Twos complement notation is used inside the data path. Intermediate results from calculations are stored in a  $64 \times 30$ -bit wide data RAM. Data and Programmable Gain Amplifier (PGA) settings are read in via 7 input ports and written back into 3 output ports.

The instruction path uses a 16-bit format with the 4 MSBs designating the opcode and the trailing 12 bits used to describe the operand. The VSP has 12 major instructions; some instructions use two opcodes (operation codes). The addressing range is 9 bits wide, allowing for a total of 512 instructions, which is more than adequate for the filter types it is intended to calculate. Some room is available for Built-In Self Test (BIST). The ALU consists of a 30-bit subtractor, a 30-bit adder and a  $30 \times 16$ -bit 'modified booth'-type parallel multiplier.

The VSP's accumulator has built-in overrange checking and will limit values to their minimum (in case of underflow) or maximum (in case of overflow) value.

The VSP engine is designed to operate at 4 MIPS on a 8 kHz PCM signal.

All instructions take one clock-cycle to complete. It should be noted that since the noise shaper operates at a sample rate of 32 kHz and the voice band filter operates at a sample rate of 40 kHz it is necessary to transfer 4 samples to the receive output and to read 5 samples from transmit input for each frame.

No buffering is foreseen for these samples, which means that the VSP program is responsible for proper spacing in time of the input- and output samples. Failure to ensure proper spacing will result in heavily distorted signals.

Synchronization to the 8 kHz frame-sync signals AFS is also done under program control. The VSP program must ensure that noise shaper and FIR filter are properly reset before actual operation is started.

A VSP-emulator and a VSP-assembler have been written in order to facilitate program development. The assembler generates a stream of 16-bit words that need to be loaded into the instruction RAM. This is done by repeated writes to the VSP control register. The sequence would be as follows:

1. Write address into the VSP instruction RAM program counter register
2. Write the upper 8 bits into the VSP instruction RAM data high-byte register
3. Write the lower 8 bits into the VSP instruction RAM data low-byte register.

This sequence should be repeated until the VSP is fully programmed. Programming can only be done when the VSP is not active. The VSP program counter will be set to location 0 and operation starts after enabling voice band transmit or voice band receive. See also the CSI description in Chapter 12.

Baseband and audio interface for GSM

PCF50732

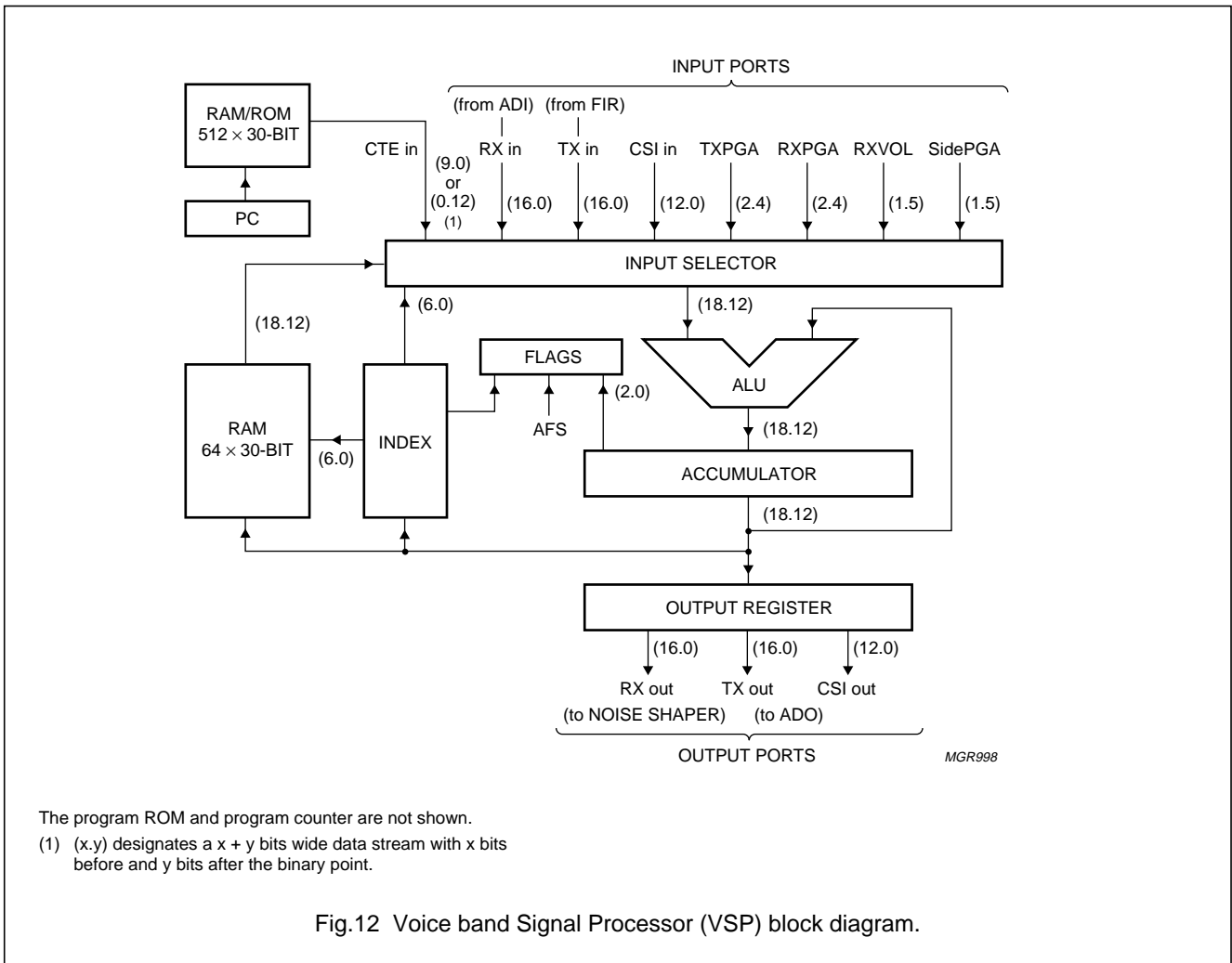

## Baseband and audio interface for GSM

## PCF50732

## 13.2 VSP assembler language

The stack for return addresses is only one entry deep which means that nesting of subroutines is not possible.

**Table 30** VSP instruction set

X = don't care during a read/or write access. For the description of the bit symbols see notes 1 to 8.

MNEMONIC	INSTRUCTION	I3	I2	I1	I0	D11	D10	D9	D8	D7	D6	D5	D4	D3	D2	D1	D0
LDA	Load accumulator	0	0	0	m3	c11	c10	c9	c8	c7	c6	c5	c4	c3	c2	c1	c0
					m3	m2	m1	m0	d8	d7	d6	d5	d4	d3	d2	d1	d0
STO	Store accumulator	0	0	1	0	m2	m1	m0	X	X	X	d5	d4	d3	d2	d1	d0
RTN	Return from subroutine	0	0	1	1	X	X	X	X	X	X	X	X	X	X	X	X
ADD	Add to accumulator	0	1	0	m3	c11	c10	c9	c8	c7	c6	c5	c4	c3	c2	c1	c0
					m3	m2	m1	m0	d8	d7	d6	d5	d4	d3	d2	d1	d0
SUB	Subtract from accumulator	0	1	1	m3	c11	c10	c9	c8	c7	c6	c5	c4	c3	c2	c1	c0
					m3	m2	m1	m0	d8	d7	d6	d5	d4	d3	d2	d1	d0
MUL	Multiply with accumulator	1	0	0	m3	c11	c10	c9	c8	c7	c6	c5	c4	c3	c2	c1	c0
					m3	m2	m1	m0	d8	d7	d6	d5	d4	d3	d2	d1	d0
JMFS	Jump if flag set	1	0	1	0	f2	f1	f0	a8	a7	a6	a5	a4	a3	a2	a1	a0
JMFC	Jump if flag clear	1	0	1	1	f2	f1	f0	a8	a7	a6	a5	a4	a3	a2	a1	a0
JSFS	Jump subroutine if flag set	1	1	0	0	f2	f1	f0	a8	a7	a6	a5	a4	a3	a2	a1	a0
JSFC	Jump subroutine if flag clear	1	1	0	1	f2	f1	f0	a8	a7	a6	a5	a4	a3	a2	a1	a0
STF	Set/clear flag	1	1	1	0	f2	f1	f0	X	X	X	X	X	X	X	X	d0
IDX	Index operations	1	1	1	1	im2	im1	im0	X	X	X	i5	i4	i3	i2	i1	i0

## Notes

1. c11 to c0 denotes a 12-bit twos complement coefficient between  $-1$  and  $+1$ .
2. m3 to m0 denotes a 4-bit instruction mode descriptor.
3. f2 to f0 denotes a 3-bit flag descriptor.
4. a8 to a0 denotes a 9-bit address.
5. i5 to i0 denotes a 6-bit index register value.
6. a8 to a0 denotes a 9-bit address.
7. X is a don't care bit.
8. im2 to im0 denotes a 3-bit instruction mode descriptor for the IDX operator.

## Baseband and audio interface for GSM

## PCF50732

**Table 31** Mode descriptions

m3	m2	m1	m0	MODE NAME	OPERAND	RANGE	ASSEMBLER SHORT HAND
0	0	0	0	register	R(d5 to d0)	register 0 to 63	r
0	0	0	1	register indexed	R((d5 to d0) + index)	register 0 to 63	i
0	0	1	0	port	P(d2 to d0)	ports 0 to 7	p
0	0	1	1	small integer	d8 to d0	-256 to +255; note 1	s
0	1	0	0	index	index	0 to 63; note 1	i
1	bits 11 to 0 form a 12-bit twos complement coefficient between -1 and +1						c

**Note**

- Value range in increments of 1.

**Table 32** Index mode descriptions

im2	im1	im0	NAME	OPERAND
0	0	0	store	index = d5 to d0
0	0	1	increment	index = (d5 to d0) + index
1	0	0	accu	index = accu

**Table 33** Flag descriptions

f2	f1	f0	NAME	DESCRIPTION	REMARKS	TYPE
0	0	0	ALW	always set	flag is clear in VSP test mode; used to initiate BIST	system
0	0	1	INZ	set if index not zero	used to implement loops	
0	1	0	EQ0	set if accu is all 0		
0	1	1	EQ1	set if accu is all 1		
1	0	0	SYNC	PCM sync signal	used to sync VSP to external PCM signal	
1	0	1	A	user flag A		user
1	1	0	B	user flag B		
1	1	1	C	user flag C	used to reset noise shaper and FIR filter	

**Table 34** Port descriptions

P2	P1	P0	NAME	DIRECTION	RANGE
0	0	0	Receive (RX)	read/write	-32768 to +32767 (16 bits)
0	0	1	Transmit (TX)	read/write	-32768 to +32767 (16 bits)
0	1	0	CSI	read/write	-2048 to +2047 (12 bits)
0	1	1	ZERO	read	fixed 0
1	0	0	TXPGA	read	0 to 63 (-24 to +12 dB)
1	0	1	RXPGA	read	0 to 63 (-24 to +12 dB)
1	1	0	RXVOL	read	0 to 63 (-20 to +6 dB)
1	1	1	SidePGA	read	0 to 63 (-20 to +6 dB)

Baseband and audio interface for GSM

PCF50732

13.3 Descriptions of the VSP instruction set

13.3.1 CONVENTIONS

In the descriptions of the VSP instruction set:

- A = the 30-bit accumulator
- I = the 6-bit index register
- r.a. = a 6-bit register address
- p.n. = a 3-bit port number (address)
- coeff = a 12-bit coefficient

- f.l. = a 3-bit flag descriptor
- addr = a 9-bit address
- stack = a one entry deep return address stack
- PC = a 9-bit program counter
- o.a. = the 9-bit old address
- s.i. = small integer
- X = don't care during a read/or write access.

13.3.2 LDA INSTRUCTION

The LDA (Load accumulator) instruction is used to load data into the VSP's accumulator. Flags affected are EQ0 and EQ1.

Table 35 LDA instruction

15	14	13	12	11	10	9	8	7	6	5	4	3	2	1	0	OPERATION	ASSEMBLER	NAME
0	0	0	1	coefficient											coeff → A	LDA c <coeff>	load coefficient	
0	0	0	0	0	0	0	X	X	X	register address						R(r.a.) → A	LDA r <r.a.>	load register
0	0	0	0	0	0	1	X	X	X	register address						R(r.a. + I) → A	LDA i <r.a.>	load register indexed
0	0	0	0	0	1	0	X	X	X	X	X	X	port number			P(p.n.) → A	LDA p <p.n.>	load port
0	0	0	0	0	1	1	small integer									s.i. → A	LDA s <s.i.>	load integer
0	0	0	0	1	0	0	X	X	X	X	X	X	X	X	X	I → A	LDA x	load index

13.3.3 STO INSTRUCTION

The STO (Store accumulator) instruction is used to store data into register RAM or output ports. No flags are affected.

Table 36 STO instruction

15	14	13	12	11	10	9	8	7	6	5	4	3	2	1	0	OPERATION	ASSEMBLER	NAME
0	0	1	0	0	0	0	X	X	X	register address						A → R(r.a.)	STO r <r.a.>	store register
0	0	1	0	0	0	1	X	X	X	register address						A → R(r.a. + I)	STO i <r.a.>	store register indexed
0	0	1	0	0	1	0	X	X	X	X	X	X	port number			A → P(p.n.)	STO p <p.n.>	store port

## Baseband and audio interface for GSM

## PCF50732

## 13.3.4 ADD INSTRUCTION

The ADD (Add to accumulator) instruction is used to add data to the VSP's accumulator. Flags affected are EQ0 and EQ1.

Table 37 ADD instruction

15	14	13	12	11	10	9	8	7	6	5	4	3	2	1	0	OPERATION	ASSEMBLER	NAME
0	1	0	1	coefficient											$A + \text{coeff} \rightarrow A$	ADD c <coeff>	add coefficient	
0	1	0	0	0	0	0	X	X	X	register address						$A + R(\text{r.a.}) \rightarrow A$	ADD r <r.a.>	add register
0	1	0	0	0	0	1	X	X	X	register address						$A + R(\text{r.a.} + I) \rightarrow A$	ADD i <r.a.>	add register indexed
0	1	0	0	0	1	0	X	X	X	X	X	X	port number			$A + P(\text{p.n.}) \rightarrow A$	ADD p <p.n.>	add port
0	1	0	0	0	1	1	small integer									$A + \text{s.i.} \rightarrow A$	ADD s <s.i.>	add integer
0	1	0	0	1	0	0	X	X	X	X	X	X	X	X	X	$A + I \rightarrow A$	ADD x	add index

## 13.3.5 SUB INSTRUCTION

The SUB (Subtract from accumulator) instruction is used to subtract data from the VSP's accumulator. Flags affected are EQ0 and EQ1.

Table 38 SUB instruction

15	14	13	12	11	10	9	8	7	6	5	4	3	2	1	0	OPERATION	ASSEMBLER	NAME
0	1	1	1	coefficient											$A - \text{coeff} \rightarrow A$	SUB c <coeff>	subtract coefficient	
0	1	1	0	0	0	0	X	X	X	register address						$A - R(\text{r.a.}) \rightarrow A$	SUB r <r.a.>	subtract register
0	1	1	0	0	0	1	X	X	X	register address						$A - R(\text{r.a.} + I) \rightarrow A$	SUB i <r.a.>	subtract register indexed
0	1	1	0	0	1	0	X	X	X	X	X	X	port number			$A - P(\text{p.n.}) \rightarrow A$	SUB p <p.n.>	subtract port
0	1	1	0	0	1	1	small integer									$A - \text{s.i.} \rightarrow A$	SUB s <s.i.>	subtract integer
0	1	1	0	1	0	0	X	X	X	X	X	X	X	X	X	$A - I \rightarrow A$	SUB x	subtract index

## 13.3.6 MUL INSTRUCTION

The MUL (Multiply with accumulator) instruction is used to multiply data with the VSP's accumulator. Flags affected are EQ0 and EQ1. The second operand of the multiplication is restricted to 16-bit; e.g. R(r.a.).

Table 39 MUL instruction

15	14	13	12	11	10	9	8	7	6	5	4	3	2	1	0	OPERATION	ASSEMBLER	NAME
1	0	0	1	coefficient											$A \times \text{coeff} \rightarrow A$	MUL c <coeff>	multiply coefficient	
1	0	0	0	0	0	0	X	X	X	register address						$A \times R(\text{r.a.}) \rightarrow A$	MUL r <r.a.>	multiply register
1	0	0	0	0	0	1	X	X	X	register address						$A \times R(\text{r.a.} + I) \rightarrow A$	MUL i <r.a.>	multiply register indexed
1	0	0	0	0	1	0	X	X	X	X	X	X	port number			$A \times P(\text{p.n.}) \rightarrow A$	MUL p <p.n.>	multiply port
1	0	0	0	0	1	1	small integer									$A \times \text{s.i.} \rightarrow A$	MUL s <s.i.>	multiply integer
1	0	0	0	1	0	0	X	X	X	X	X	X	X	X	X	$A \times I \rightarrow A$	MUL x	multiply index



## Baseband and audio interface for GSM

## PCF50732

## 13.3.7 JMFS INSTRUCTION

The JMFS (Jump if flag set) is used for conditional jumps. The jump is carried out when the flag is set, otherwise the PC is simply incremented.

**Table 40** JMFS instruction

15	14	13	12	11	10	9	8	7	6	5	4	3	2	1	0	OPERATION	ASSEMBLER
1	0	1	0	flag			address								<addr> → PC	JMFS <f.l.> <addr>	

## 13.3.8 JMFC INSTRUCTION

The JMFC (Jump if flag clear) is used for conditional jumps. The jump is carried out when the flag is clear, otherwise the PC is incremented.

**Table 41** JMFC instruction

15	14	13	12	11	10	9	8	7	6	5	4	3	2	1	0	OPERATION	ASSEMBLER
1	0	1	1	flag			address								<addr> → PC	JMFC <f.l.> <addr>	

## 13.3.9 JSFS INSTRUCTION

The JSFS (Jump subroutine if flag set) is used for conditional call to a subroutine. The jump is carried out when the flag is set, otherwise the PC is incremented. Note that the return stack is just one entry deep, so nesting of subroutines is not allowed.

**Table 42** JSFS instruction

15	14	13	12	11	10	9	8	7	6	5	4	3	2	1	0	OPERATION	ASSEMBLER
1	1	1	0	flag			address								<o.a> → stack <addr> → PC	JSFS <f.l.> <addr>	

## 13.3.10 JSFC INSTRUCTION

The JSFC (Jump subroutine if flag clear) is used for conditional jumps to a subroutine. The jump is carried out when the flag is clear, otherwise the PC is incremented. It should be noted that the return stack is just one entry deep, so nesting of subroutines is not allowed.

**Table 43** JSFC instruction

15	14	13	12	11	10	9	8	7	6	5	4	3	2	1	0	OPERATION	ASSEMBLER
1	1	1	1	flag			address								<o.a> → stack <addr> → PC	JSFC <f.l.> <addr>	

## 13.3.11 RTN INSTRUCTION

The RTN (Return from subroutine) is used to return from a subroutine.

**Table 44** RTN instruction

15	14	13	12	11	10	9	8	7	6	5	4	3	2	1	0	OPERATION	ASSEMBLER
0	0	1	1	X	X	X	X	X	X	X	X	X	X	X	X	stack → PC	RTN

## Baseband and audio interface for GSM

## PCF50732

## 13.3.12 STF INSTRUCTION

The STF (Set/clear flag) instruction is used to set or clear the user flags A, B or C. System flags cannot be set or reset under program control.

Table 45 STF instruction

15	14	13	12	11	10	9	8	7	6	5	4	3	2	1	0	OPERATION	ASSEMBLER
1	1	0	0	flag			X	X	X	X	X	X	X	X	value	<value> → <f.l.>	STF <f.l.> <value>

## 13.3.13 IDX INSTRUCTION

The IDX (Index operations) instruction is used to store and increment/decrement index values. It should be noted that additions to the index register is done in modulo 64. A 'decrement index register by one' could therefore be programmed as 'IDX + 63'. The 'IDX A' instruction loads the 6 bits to the left of the binary point into the index register, i.e. it stores the integer part modulo 64 into I.

Table 46 IDX instruction

15	14	13	12	11	10	9	8	7	6	5	4	3	2	1	0	OPERATION	ASSEMBLER
1	1	0	1	0	0	0	X	X	X	value					<value> → I	IDX = <value>	
1	1	0	1	0	0	1	X	X	X	value					I + <value> → I	IDX + <value>	
1	1	0	1	1	0	0	X	X	X	X	X	X	X	X	X	A → I	IDX A

## 13.4 The assembler/emulator

A 2-pass assembler and an emulator was made to assist with the development of VSP programs. The software programs are written in 'C' and currently run under NT, HPUX and LINUX operating systems. The assembler reads assembler source files and produces a log file, sets of VHDL or Verilog stimuli and an output file containing CSI instructions that, when loaded, will load the executable into the VSP RAM.

Requirements for the assembler source code are:

- One instruction or pseudo instruction (see Table 47) per line
- No empty lines
- A maximum of 512 instructions
- Operation always starts at instruction 0.

Table 47 Assembler pseudo instructions

MNEMONIC	INSTRUCTION	DEFINITION
. label	{<.>< ><label>}	Defines a location inside the source code. Is usually used as an argument to JMF/JSF instructions.
define	{<define>< ><label> < ><value>}	Defines a variable and assigns a value to it. These variables can then be referenced in the assembler instructions.
include	{<include>< ><file name>}	Reads in another source code file and then continues with the current file.
--	{<-->< ><comment>}	Defines a comment; the rest of the line is skipped.

## Baseband and audio interface for GSM

## PCF50732

**14 LIMITING VALUES**

In accordance with Absolute Maximum Rating System (IEC 134).

SYMBOL	PARAMETER	MIN.	MAX.	UNIT
$V_{DD}$	supply voltage	-0.5	+3.3	V
$I_{DD}$	supply current	-	30	mA
$I_{I1}$	DC current into any pin; except EARP/EARN, AUXSP and BUZ	-10	+10	mA
$I_{I2}$	DC current into pins EARP/EARN, AUXSP and BUZ	-100	+100	mA
$V_I$	input voltages on all inputs	-0.5	$V_{DD} + 0.5$	V
$P_{tot}$	total power dissipation	-	800	mW
$T_{amb}$	operating ambient temperature	-40	+85	°C
$T_{stg}$	storage temperature	-65	+150	°C

**15 THERMAL CHARACTERISTICS**

SYMBOL	PARAMETER	CONDITIONS	VALUE	UNIT
$R_{th(j-a)}$	thermal resistance from junction to ambient	in free air	80	K/W

**16 DC CHARACTERISTICS** $T_{amb} = -40$  to  $+85$  °C;  $V_{SS} = 0$  V (ground pins must be interconnected externally);  $V_{DDA} \geq V_{DDD}$ ; $V_{DDA(bb)} = V_{DDA(vb)} = V_{DDA(vbo)} = V_{DDA(ref)} = V_{DDA} = 2.5$  to  $2.75$  V (supply pins must be interconnected externally); all voltages with respect to  $V_{SS}$  unless otherwise specified.

SYMBOL	PARAMETER	CONDITIONS	MIN.	TYP.	MAX.	UNIT
$I_{stb(tot)}$	total standby current		-	10	-	$\mu$ A
$P_{av}$	average power consumption	$V_{DDD} = 1.5$ V; $V_{DDA} = 2.7$ V; without load on audio outputs EARP, EARN, AUXSP and BUZ	-	15	-	mW
<b>Digital power supply: <math>V_{DDD}</math></b>						
$V_{DDD}$	digital supply voltage		1.0	1.5	2.75	V
<b>Digital inputs: CCLK, CEN, CDI, TXON, RXON, AUXST, ADI, AFS, ACLK and RESET</b>						
$V_{IL}$	LOW-level input voltage		0.0	-	$0.3V_{DDD}$	V
$V_{IH}$	HIGH-level input voltage		$0.7V_{DDD}$	-	$V_{DDD}$	V
$I_{LI}$	input leakage current		-	$\pm 1$	-	$\mu$ A
<b>Digital outputs: BIEN, BOEN, ADO and AMPCTRL</b>						
$V_{OL}$	LOW-level output voltage	$I_{sink} = 1.5$ mA	-	-	$0.2V_{DDD}$	V
$V_{OH}$	HIGH-level output voltage	$I_{source} = 1.5$ mA	$0.7V_{DDD}$	-	-	V
<b>Digital output: BIOCLK</b>						
$V_{OL}$	LOW-level output voltage	$I_{sink} = 1.5$ mA	-	-	$0.2V_{DDD}$	V
$V_{OH}$	HIGH-level output voltage	$I_{source} = 1.5$ mA	$0.7V_{DDD}$	-	-	V

## Baseband and audio interface for GSM

## PCF50732

SYMBOL	PARAMETER	CONDITIONS	MIN.	TYP.	MAX.	UNIT
<b>Digital bidirectional pins: CDO and BDIO</b>						
$V_{IL}$	LOW-level input voltage		0.0	–	$0.3V_{DDD}$	V
$V_{IH}$	HIGH-level input voltage		$0.7V_{DDD}$	–	$V_{DDD}$	V
$I_{LI}$	input leakage current		–	$\pm 1$	–	$\mu\text{A}$
$V_{OL}$	LOW-level output voltage	$I_{\text{sink}} = 1.5 \text{ mA}$	–	–	$0.2V_{DDD}$	V
$V_{OH}$	HIGH-level output voltage	$I_{\text{source}} = 1.5 \text{ mA}$	$0.7V_{DDD}$	–	–	V
<b>Low-swing clock input: MCLK</b>						
$I_{LI}$	input leakage current		–	$\pm 1$	–	$\mu\text{A}$
<b>Analog power supplies: <math>V_{DDA(\text{bb})}</math>, <math>V_{DDA(\text{vb})}</math>, <math>V_{DDA(\text{vbo})}</math> and <math>V_{DDA(\text{ref})}</math></b>						
$V_{DDA}$	analog supply voltage		2.5	2.7	2.75	V
$I_{DDA}$	analog supply current	$V_{DDD} = 1.5 \text{ V};$ $V_{DDA} = 2.7 \text{ V};$ RXON active	–	3.5	–	mA
<b>Analog reference pin: <math>V_{\text{ref}}</math></b>						
$V_{\text{ref}}$	DC reference level	no external load	–	1.25	–	V
$I_{I(\text{ref})}$	input source/sink current		–	0.1	–	$\mu\text{A}$
<b>Analog output pins: IP, IN, QP and QN</b>						
$V_{\text{bias}(\text{TXIQ})}$	DC bias level		1.175	1.25	1.325	V
<b>Analog input pins: MICP and MICN</b>						
$V_{\text{ref}(\text{MIC})}$	DC input reference level		–	$0.5V_{\text{ref}}$	–	V
<b>Analog input pins: AUXMICP and AUXMICN</b>						
$V_{\text{ref}(\text{AUXMIC})}$	DC input reference level		–	$0.5V_{\text{ref}}$	–	V
<b>Analog output pins: EARP and EARN</b>						
$V_{\text{bias}(\text{EAR})}$	DC bias level		–	$V_{\text{ref}}$	–	V
<b>Analog output pin: AUXSP</b>						
$V_{\text{bias}(\text{AUX})}$	DC bias level		–	$V_{\text{ref}}$	–	V
<b>Analog output pin: BUZ</b>						
$V_{\text{bias}(\text{BUZ})}$	DC bias level		–	$V_{\text{ref}}$	–	V

## Baseband and audio interface for GSM

## PCF50732

**17 AC CHARACTERISTICS**

$V_{DD} = 1.0$  to  $2.75$  V;  $V_{DDA} = 2.5$  to  $2.75$  V;  $T_{amb} = -40$  to  $+85$  °C; unless otherwise specified.

SYMBOL	PARAMETER	CONDITIONS	MIN.	TYP.	MAX.	UNIT
$f_{clk}$	master clock frequency		–	13.0	–	MHz
<b>Digital input pins: CCLK, CEN, CDI, TXON, RXON, AUXST, ADI, AFS, ACLK and RESET</b>						
$C_i$	input capacitance		–	5.0	–	pF
<b>Digital output pins: BIOCLK, BIEN, BOEN, ADO and AMPCTRL</b>						
$t_{dLHO}$	output rise time	output load = 10 pF	–	10	–	ns
$t_{dHLO}$	output fall delay	output load = 10 pF	–	10	–	ns
<b>Digital bidirectional pins: CDO and BDIO</b>						
$C_i$	input capacitance		–	5.0	–	pF
$t_{dLHO}$	output rise time	output load = 20 pF	–	10	–	ns
$t_{dHLO}$	output fall delay	output load = 20 pF	–	10	–	ns
<b>Low-swing clock input: MCLK</b>						
$V_{MCLK}$	input amplitude	note 1	0.1	–	$0.5V_{DD}$	V
$\delta_{MCLK}$	duty cycle		40	–	60	%
<b>Analog output pins: IP, IN, QP and QN</b>						
$t_{st(TXIQ)}$	output settling time	output load = 10 pF // 10 k $\Omega$ , to 1 LSB, for 0.8 to 2.2 V	–	9.6	–	$\mu$ s
$R_{o(TXIQ)}$	output resistance	$f < 100$ kHz	–	105	–	$\Omega$
<b>Analog input pins: IP, IN, QP and QN</b>						
$R_{i(RXIQ)}$	input resistance	differential	200	–	–	k $\Omega$
$C_{i(RXIQ)}$	input capacitance		–	5	–	pF
<b>Analog input pins: AUXADC1, AUXADC2, AUXADC3 and AUXADC4</b>						
$R_{i(AUXADC)}$	input resistance		–	1	–	M $\Omega$
<b>Analog input pins: MICP and MICN</b>						
$R_{i(eq)(MIC)}$	equivalent input resistance	differential	200	220	320	k $\Omega$
<b>Analog input pin: AUXMICP and AUXMICN</b>						
$R_{i(eq)(AUXMIC)}$	equivalent input resistance		200	220	–	k $\Omega$
<b>Analog output pins: EARP and EARN</b>						
$R_{o(EARAMP)}$	output resistance	$f = 1$ kHz	0	–	1	$\Omega$
<b>Analog output pin: AUXSP</b>						
$R_{o(AUXAMP)}$	output resistance	$f = 1$ kHz	0	–	1	$\Omega$
<b>Analog output pin: BUZ</b>						
$R_{o(BUZ)}$	output resistance	$f = 1$ kHz	0	–	1	$\Omega$

**Note**

1. Input MCLK is internally AC coupled; the signal must not go below  $V_{SS}$  or above  $V_{DD}$ .

## Baseband and audio interface for GSM

## PCF50732

## 18 FUNCTIONAL CHARACTERISTICS

## 18.1 Baseband transmit (BSI to TXI/Q)

$V_{DDA} = 2.5$  to  $2.75$  V;  $T_{amb} = -40$  to  $+85$  °C.

SYMBOL	PARAMETER	CONDITIONS	MIN.	TYP.	MAX.	UNIT
RES <sub>TXIQ</sub>	resolution of TX DACs		–	10	–	bit
S/N <sub>TXIQ</sub>	signal-to-noise TX DACs		–	55	–	dB
FSIN <sub>TXIQ</sub>	input sampling frequency		–	270.833	–	kHz
V <sub>O(TXIQ)(p-p)</sub>	output signal amplitude (peak-to-peak value)	note 1	0.9	1.0	1.1	V
V <sub>DC(TXIQ)</sub>	output DC level		1.15	1.25	1.35	V
AMAT <sub>TXIQ</sub>	output amplitude matching between I and Q TX paths	note 1	–1.75 –0.15	–	+1.75 +0.15	% dB
VOFS <sub>TXIQ</sub>	differential DC offset voltage between IP/IN or QP/QN	note 1	–4.5	–	+4.5	mV
FRESP <sub>TXIQ</sub>	frequency response of random output signal	f = 0 to 100 kHz	–3	–	–	dB
		f = 200 kHz	–	–	–30	dB
		f = 250 kHz	–	–	–33	dB
		f = 400 kHz	–	–	–60	dB
		f = 600 kHz	–	–	–70	dB
		f = 1200 kHz	–	–	–70	dB
		f > 1800 kHz	–	–	–70	dB
MPEI <sub>TXIQ</sub>	maximum phase effect instance	note 2	–	22	–	µs
AGD <sub>TXIQ</sub>	absolute group delay	note 1	–	10	–	µs
GDL <sub>TXIQ</sub>	group delay linearity	measured at full-scale; 10 kHz < f < 100 kHz; load: 10 pF // 10 kΩ	–	100	–	ns
GDMAT <sub>TXIQ</sub>	group delay matching of I and Q TX paths		–	–	40	ns
PMAT <sub>TXIQ</sub>	phase matching of I and Q TX paths	note 1	–	0.5	–	deg
PTERMS <sub>TXIQ</sub>	RMS phase trajectory error	random input pattern; notes 1 and 3	–	0.5	0.8	deg
PTEPEAK <sub>TXIQ</sub>	peak phase trajectory error		–	1.5	3.0	deg

## Notes

1. Measured at full-scale; load: 10 pF // 10 kΩ; f = 67 kHz.
2. Not tested. Defined between the rising edge of BIOCLK which latches a data bit at BDIO to its corresponding maximum phase change on the analog outputs ITX and QTX.
3. Not tested.

## Baseband and audio interface for GSM

## PCF50732

**18.2 Baseband receive (RXI/Q to BSI)**

$V_{DDA} = 2.5$  to  $2.75$  V;  $T_{amb} = -40$  to  $+85$  °C; all values valid for ZIF and NZIF modes.

SYMBOL	PARAMETER	CONDITIONS	MIN.	TYP.	MAX.	UNIT
RES <sub>RXIQ</sub>	resolution	I and Q word length at BSI	–	12	–	bit
S/N <sub>RXIQ</sub>	signal to noise ratio		–	66	–	dB
V <sub>ICM(RXIQ)</sub>	input common mode voltage	(IP + IN)/2; (QP + QN)/2; referred to V <sub>SS</sub>	1.0	1.25	1.5	V
V <sub>IDM(RXIQ)</sub>	input differential voltage	(IP – IN); (QP – QN)	–1.5	–	1.5	V
FSIN <sub>RXIQ</sub>	input sampling frequency	Baseband receive control register = 0X	–	6.5	–	MHz
		Baseband receive control register = 1X	–	13	–	MHz
FSOUT <sub>RXIQ</sub>	output sample rate	Baseband receive control register = 00 or 11	–	270.833	–	kHz
		Baseband receive control register = 10	–	541.667	–	kHz
FRESP <sub>RXIQ</sub>	frequency response	Baseband receive control register = 0X; note 1				
		f = 0 to 70 kHz; V <sub>IDM(RXIQ)</sub> = 150 mV (p-p)	–0.8	0	+0.3	dB
		f = 90 kHz; V <sub>IDM(RXIQ)</sub> = 150 mV (p-p)	–	–3.5	–	dB
		f = 100 kHz; V <sub>IDM(RXIQ)</sub> = 150 mV (p-p)	–	–5.5	–	dB
		f = 200 kHz; V <sub>IDM(RXIQ)</sub> = 150 mV (p-p)	–	–	–35	dB
		f > 220 kHz; V <sub>IDM(RXIQ)</sub> = 150 mV (p-p)	–	–	–45	dB
		Baseband receive control register = 1X; note 1 and 2				
		f = 0 to 140 kHz; V <sub>IDM(RXIQ)</sub> = 150 mV (p-p)	–0.8	0	+0.3	dB
		f = 180 kHz; V <sub>IDM(RXIQ)</sub> = 150 mV (p-p)	–	–3.5	–	dB
		f = 200 kHz; V <sub>IDM(RXIQ)</sub> = 150 mV (p-p)	–	–5.5	–	dB
f = 400 kHz; V <sub>IDM(RXIQ)</sub> = 150 mV (p-p)	–	–	–35	dB		
f > 440 kHz; V <sub>IDM(RXIQ)</sub> = 150 mV (p-p)	–	–	–45	dB		
DYN <sub>RXIQ</sub>	dynamic signal range					
	ZIF mode	f = 20 Hz to 135 kHz	60	68	–	dB
	NZIF mode	f = 20 Hz to 270 kHz	60	68	–	dB
SINAD <sub>RXIQ</sub>	signal to noise and distortion ratio	f = 20.0 kHz; V <sub>IDM(RXIQ)</sub> = 2 V (p-p)	40	–	–	dB
		f = 67.7 kHz; V <sub>IDM(RXIQ)</sub> = 2 V (p-p)	–	65	–	dB
		f = 20 kHz; V <sub>IDM(RXIQ)</sub> = 150 mV (p-p)	–	40	–	dB
		f = 67.7 kHz; V <sub>IDM(RXIQ)</sub> = 150 mV (p-p)	–	40	–	dB
OPC	output code in BDIO	for maximum input amplitude	–	±1440	–	LSB
PSRR <sub>RXIQ</sub>	power supply ripple rejection	applying a 100 mV (p-p)/217 Hz sine wave on top of the analog power supply	–	70	–	dB
GERR <sub>RXIQ</sub>	gain error	referenced to maximum amplitude	–6	–	+6	%
			–0.5	–	+0.5	dB
GMAT <sub>RXIQ</sub>	gain matching error	at maximum input level	–3	–	+3	%
			–0.25	–	+0.25	dB
GDMAT <sub>RXIQ</sub>	group delay matching of I and Q RX paths	measured at full-scale; 10 kHz < f < 100 kHz; output load = 10 pF // 10 kΩ	–	–	5	ns

## Baseband and audio interface for GSM

## PCF50732

SYMBOL	PARAMETER	CONDITIONS	MIN.	TYP.	MAX.	UNIT
OFFS <sub>RXIQ</sub>	offset error	before compensation	-40	-	+40	mV
		after compensation	-5	-	+5	mV
POST <sub>RXIQ</sub>	power-on settling time ZIF mode NZIF mode	including decimation filter	-	52	-	μs
			-	26	-	μs
FGD <sub>RXIQ</sub>	filter group delay ZIF mode NZIF mode	-	23	-	μs	
		-	11.5	-	μs	

**Notes**

1. Reference level is full-scale input at 67 kHz.
2. This will not be tested.



## Baseband and audio interface for GSM

## PCF50732

**18.3 Voice band transmit (microphone to ASI)**
 $V_{DDA} = 2.5$  to  $2.75$  V;  $T_{amb} = -40$  to  $+85$  °C.

SYMBOL	PARAMETER	CONDITIONS	MIN.	TYP.	MAX.	UNIT
RES <sub>MICADC</sub>	resolution of ADC		–	13	–	bit
FSIN <sub>MICADC</sub>	internal sampling frequency		–	1000	–	kHz
GRAN <sub>TXPGA</sub>	calibration gain range		–24	0	+12	dB
GSTP <sub>TXPGA</sub>	calibration gain step size	see Table 25	–	64	–	steps
GTOL <sub>VBTX</sub>	gain tolerance of coder	at TXPGA = 0 dB	–1.5	–	+1.0	dB
FRESP <sub>VBTX</sub>	digital filter frequency response of implemented standard VSP software (version: vb5_all)	f < 100 Hz	–	–	–20	dB
		100 Hz < f < 200 Hz	–	–	–10	dB
		f = 300 Hz to 3.3 kHz	–1	–	+1	dB
		f = 3.3 to 3.4 kHz	–1.5	–	0	dB
		f ≥ 4 kHz	–	–	–20	dB
FREJ <sub>VBTX</sub>	out-of-band rejection	f = 4.6 kHz	40	45	–	dB
		f = 6 to 30 kHz	45	50	–	dB
<b>Microphone/auxiliary signal path</b>						
V <sub>IN(rms)</sub>	nominal input level (RMS value)	TXPGA = 0 dB, MICH1 = 1	–	–35	–	dBm
		TXPGA = 0 dB, MICH1 = 0	–	–7	–	dBm
N <sub>IDLE</sub>	idle noise level (pin ADO)	psophometrically weighted <sup>(1)</sup> ; T <sub>amb</sub> = 25 °C	–	–	–75	dBm0p <sup>(2)</sup>
THD	total harmonic distortion	f = 1 kHz; PGA = –4 dB; ADO = +2 dBm0	–	–	1	%
SINAD	signal-to-noise and distortion	ADO = 3 dBm0	30	–	–	dB
		ADO = 0 dBm0	40	–	–	dB
		ADO = –10 dBm0	45	–	–	dB
		ADO = –20 dBm0	45	–	–	dB
		ADO = –30 dBm0	40	–	–	dB
		ADO = –40 dBm0	30	–	–	dB
PSCT <sub>VBTX</sub>	power supply crosstalk	ADO = –45 dBm0	25	–	–	dB
		applying a 100 mV (p-p)/217 Hz sine wave on top of the analog power supply	–	–	2	LSB
<b>Audio Serial Interface (ASI)</b>						
FASOUT	PCM output bit rate		128	–	2048	kbits/s
FSYNC <sub>AFS</sub>	PCM frame synchronization frequency at pin AFS		–	8	–	kHz

**Notes**

1. Psophometrical weighting: a frequency weighting curve described in "ITU recommendation O.41".
2. The unit dBm0p: 0 dBm0p is generally defined as –3.14 dBFS, where dBFS denotes dB full scale, i.e. a signal with an amplitude covering the complete range of digital values. The suffix 'p' refers to psophometrical weighting.

## Baseband and audio interface for GSM

## PCF50732

**18.4 Voice band receive (ASI to earphone)** $V_{DDA} = 2.5$  to  $2.75$  V;  $T_{amb} = -40$  to  $+85$  °C

SYMBOL	PARAMETER	CONDITIONS	MIN.	TYP.	MAX.	UNIT
RES <sub>EARDAC</sub>	resolution of DAC		–	13	–	bit
FSIN <sub>EARDAC</sub>	internal sampling frequency		–	1000	–	kHz
GRAN <sub>VOL</sub>	gain step range		–30	–12	+6	dB
GSTP <sub>VOL</sub>	gain step size	digital steps; see Table 25	–	64	–	steps
GRAN <sub>PGA</sub>	calibration PGA range		–24	–	+12	dB
GSTP <sub>PGA</sub>	gain step size	digital steps; see Table 25	–	64	–	steps
GTOL <sub>VBRX</sub>	gain tolerance of decoder		–1	–	+1	dB
GMUTE <sub>VBRX</sub>	mute attenuation of decoder		40	–	–	dB
FRESP <sub>VBRX</sub>	digital filter frequency response of implemented standard VSP software (version: vb5_all)	f = 0 to 100 Hz	–	–	–20	dB
		f = 300 to 3300 Hz	–1.0	–	+1.0	dB
		f = 3300 to 3400 Hz	–2.0	–	+1.0	dB
		f = 4000 Hz	–	–	–18	dB
FREJ <sub>VBRX</sub>	out-of-band rejection	f = 4600 Hz	38	–	–	dB
		f = 28.6 kHz	40	–	–	dB
<b>Audio Serial Interface (ASI)</b>						
FASIN	PCM input bit rate		128	–	2048	kbits/s
FSYNC <sub>AFS</sub>	PCM frame synchronization frequency at pin AFS		–	8	–	kHz
<b>Earphone output: EARP and EARN</b>						
V <sub>ref(EAR)</sub>	DC reference level		–	V <sub>ref</sub>	–	V
V <sub>o(EAR)(p-p)</sub>	output voltage (peak-to-peak value)	load: 16 Ω differential	–	2	–	V
		load: 8 Ω single-ended	–	1.5	–	V
I <sub>o(EAR)peak</sub>	output source/sink current	load: 8 Ω single-ended	–	100	–	mA
GAIN <sub>EARVOL</sub>	nominal gain from ASI to EARP/EARN	GRAN <sub>VOL</sub> = –12 dB; load 32 Ω differential	–13	–12	–11	dB
		single-ended	–19	–18	–17	dB
GRAN <sub>SIDVOL</sub>	total sidetone gain (from MICP/MICN to EARP/EARN)		+5	–	+41	dB
THD <sub>EAR</sub>	total harmonic distortion	GRAN <sub>EARVOL</sub> = –12 dB	–	–	1	%
IDLN <sub>EAR</sub>	idle noise at EARP/EARN	psophometrically weighted <sup>(1)</sup> ; GRAN <sub>EARPGA</sub> = 0 dB	–	–	–72	dBmp <sup>(2)</sup>

## Baseband and audio interface for GSM

## PCF50732

SYMBOL	PARAMETER	CONDITIONS	MIN.	TYP.	MAX.	UNIT
SINAD <sub>EAR</sub>	signal-to-noise and distortion ratio from ASI to earphone	psophometrically weighted <sup>(1)</sup>				
		at 3 dBm <sub>0</sub> input signal level	30	–	–	dB
		at 0 dBm <sub>0</sub> input signal level	35	–	–	dB
		at –10 dBm output signal level	45	–	–	dB
		at –20 dBm output signal level	42	–	–	dB
		at –30 dBm output signal level	40	–	–	dB
		at –40 dBm output signal level	30	–	–	dB
		at –45 dBm output signal level	25	–	–	dB
PSRR <sub>EAR</sub>	power supply ripple rejection at EARP/EARN	applying a 100 mV (p-p)/217 Hz sine wave on top of the analog power supply	70	–	–	dB
<b>Auxiliary output: AUXSP</b>						
V <sub>ref(AUXSP)</sub>	DC reference level		–	V <sub>ref</sub>	–	V
V <sub>o(AUXSP)</sub>	output voltage	load: 16 Ω with 47 μF in series to ground	–	V <sub>ref</sub> ±1	–	V
		load: 8 Ω with 100 μF in series to ground	–	V <sub>ref</sub> ±0.77	–	V
I <sub>o(AUXSP)peak</sub>	output source/sink current	load: 16 Ω with 47 μF in series to ground	–	62.5	–	mA
GAIN <sub>AUXSP</sub>	nominal gain from ASI to AUXSP	load: 16 Ω with 47 μF in series to ground; GRAN <sub>VOL</sub> = –12 dB	–19	–18	–17	dB
<b>Buzzer output: BUZ</b>						
V <sub>ref(BUZ)</sub>	DC reference level		–	V <sub>ref</sub>	–	V
V <sub>o(BUZ)</sub>	output voltage	load: 8 Ω with 100 μF in series to ground	–	V <sub>ref</sub> – 0.77	–	V
I <sub>o(BUZ)peak</sub>	output source/sink current		–	100	–	mA
GAIN <sub>BUZ</sub>	nominal gain from ASI to BUZ	load: 8 Ω with 100 μF in series to ground; GRAN <sub>VOL</sub> = –12 dB	–19	–18	–17	dB

**Notes**

1. Psophometrical weighting: a frequency weighting curve described in “ITU recommendation O.41”.
2. The unit dBmp: 0 dBmp refers to a voltage of a signal of 1 mW across a 600 Ω load. The suffix ‘p’ refers to psophometrical weighting.

## Baseband and audio interface for GSM

## PCF50732

## 18.5 Auxiliary digital-to-analog converters

 $V_{DDA} = 2.5$  to  $2.75$  V;  $T_{amb} = -40$  to  $+85$  °C.

SYMBOL	PARAMETER	CONDITIONS	MIN.	TYP.	MAX.	UNIT
<b>AUXDAC1</b>						
RES <sub>DAC1</sub>	resolution		–	8	–	bit
VOMIN <sub>DAC1</sub>	minimum output voltage	register value: 000H	0	–	0.15	V
VOMAX <sub>DAC1</sub>	maximum output voltage	register value: 0FFH	2.1	2.2	2.3	V
VDEF <sub>DAC1</sub>	output voltage after reset	register value: 085H	–	1.147	–	V
MON <sub>DAC1</sub>	monotonicity range		–	8	–	bit
INL <sub>DAC1</sub>	integral non-linearity <sup>(1)</sup>		–5.0	–	+5.0	LSB
DNL <sub>DAC1</sub>	differential non-linearity <sup>(2)</sup>		–1.0	–	+1.0	LSB
OFFS <sub>DAC1</sub>	offset error		–80	–	+80	mV
FSST <sub>DAC1</sub>	full-scale settling time	load: 50 pF // 2 kΩ, to V <sub>SS</sub> ;	–	40	–	μs
LSBST <sub>DAC1</sub>	one LSB settling time	see Fig.13a	–	8	–	μs
<b>AUXDAC2</b>						
RES <sub>DAC2</sub>	resolution		–	12	–	bit
VOMIN <sub>DAC2</sub>	minimum output voltage	register value: 000H	0	–	0.15	V
VOMAX <sub>DAC2</sub>	maximum output voltage	register value: FFFH	2.1	2.2	2.32	V
VDEF <sub>DAC2</sub>	output voltage after reset	register value: 800H	–	1.1	–	V
MON <sub>DAC2</sub>	monotonicity range		–	12	–	bit
INL <sub>DAC2</sub>	integral non-linearity <sup>(1)</sup>		–	±10	–	LSB
DNL <sub>DAC2</sub>	differential non-linearity <sup>(2)</sup>		–1.0	–	+2.0	LSB
OFFS <sub>DAC2</sub>	offset error		–25	–	+25	mV
FSST <sub>DAC2</sub>	full-scale settling time	load: 50 pF // 10 kΩ, to	–	40	–	μs
LSBST <sub>DAC2</sub>	one LSB settling time	V <sub>SS</sub> ; see Fig.13b	–	8	–	μs
POST <sub>DAC2</sub>	power-on settling time	see Section 18.1	–	–	4	ms
<b>AUXDAC3</b>						
RES <sub>DAC3</sub>	resolution		–	10	–	bit
VOMIN <sub>DAC3</sub>	minimum output voltage	register value: 000H	0	–	0.15	V
VOMAX <sub>DAC3</sub>	maximum output voltage	register value: 3FFH	2.1	2.2	2.3	V
MON <sub>DAC3</sub>	monotonicity range		–	10	–	bit
INL <sub>DAC3</sub>	integral non-linearity <sup>(1)</sup>		–5.0	–	+5.0	LSB
DNL <sub>DAC3</sub>	differential non-linearity <sup>(2)</sup>		–1.0	–	+1.0	LSB
OFFS <sub>DAC3</sub>	offset error		–40	–	+40	mV
FSST <sub>DAC3</sub>	full-scale settling time	load: 50 pF // 1 kΩ, to V <sub>SS</sub> ;	1	10	15	μs
LSBST <sub>DAC3</sub>	one LSB settling time	see Fig.13c	–	2.5	–	μs
SSC <sub>DAC3</sub>	output source/sink current		–	–	2.5	mA

## Notes

- INL: the difference of the output to the best fit line.  $INL_{(i)} = [V_{(i)} - (a + i \times b)]/1$  LSB;  $INL = (INL_{(i)(max)} - INL_{(i)(min)})/2$ .
- DNL is the difference between individual code width and average code width (1 LSB); maximum and minimum specified.  $DNL_{(i)} = [(V_{(i+1)} - V_{(i)} - 1 \text{ LSB})/1 \text{ LSB}]$ ;  $DNL_{(min)} > -1$  is equivalent to monotonicity  $V_{(i+1)} > V_{(i)}$ .

## Baseband and audio interface for GSM

## PCF50732

**18.6 Auxiliary analog-to-digital converters: AUXADC1, AUXADC2, AUXADC3 and AUXADC4**

$V_{DDA} = 2.5$  to  $2.75$  V;  $T_{amb} = -40$  to  $+85$  °C.

SYMBOL	PARAMETER	CONDITIONS	MIN.	TYP.	MAX.	UNIT
RES <sub>AUXADC</sub>	resolution	coded in 12 bits	–	1440	–	LSB
VIN <sub>AUXADC</sub>	input voltage		0.0	–	2.0	V
VIN <sub>AUXADC</sub> MIN	V <sub>in</sub> for output code 0		–20	–	20	mV
VIN <sub>AUXADC</sub> MAX	V <sub>in</sub> for output code +1820	after offset compensation	–	2.0	–	V
R <sub>i(AUXADC)</sub>	input resistance		–	1.0	–	MΩ
INL <sub>AUXADC</sub>	integral non-linearity		–	2.5	–	mV
DNL <sub>AUXADC</sub>	differential non-linearity		–	2.5	–	mV
GERR <sub>AUXADC</sub>	gain error	V <sub>i</sub> = V <sub>ref</sub>	–0.5	–	+ 0.5	dB
OFFS <sub>AUXADC</sub>	offset error after compensation		–3	–	3	LSB
POST <sub>AUXADC</sub>	power-on settling time		–	170	–	μs

**18.7 Typical total current consumption**

The typical total current consumption values for the chip in different modes;  $T_{amb} = 25$  °C.

ACTIVITY	TOTAL CURRENT (mA)		REMARKS
	NOTE 1	NOTE 2	
Baseband transmit	3.96	4.04	baseband transmit + references + MCLK + BSI
receive	5.14	5.41	baseband receive + references + MCLK + BSI
Voice band transmit and receive	4.79	4.94	voice band transmit and receive + references + 13 MHz + auxiliary DAC2; note 3
Voice band transmit and receive baseband transmit	7.32	7.51	voice band transmit and receive + baseband transmit + references + 13 MHz + CSI + auxiliary DACs 2 and 3
baseband receive	8.52	8.91	voice band transmit and receive + baseband receive + references + 13 MHz + auxiliary DAC 2
Auxiliary ADC function	2.75	2.86	auxiliary ADC + CSI + references + 13 MHz + auxiliary DAC2
Auxiliary DAC1	2.35	2.49	auxiliary DACs 1 and 2 + references + 13 MHz
Auxiliary DAC2	1.55	1.59	auxiliary DAC2 + references + 13 MHz
Auxiliary DAC3	4.35	4.56	auxiliary DACs 3 and 2 + CSI + baseband transmit + references + 13 MHz
Idle with MCLK running	0.23	0.24	references + 13 MHz clock
Idle no MCLK; references on	0.18	0.19	references; see Section 19.1.1 "Possibility 1"
Idle	0.01	0.01	all blocks in power-down, no 13 MHz clock

**Notes**

- $V_{DDD} = 2.3$  V;  $V_{DDA} = 2.65$  V; external interface current is not included.
- $V_{DDD} = 2.6$  V;  $V_{DDA} = 2.65$  V; external interface current is not included.
- For a signal at the earpiece differential output of amplitude 'A' across a load resistance of 'R', the current 'I' must be added, where:  $I = \frac{4}{\pi} \cdot \frac{A}{R}$ .

$$I = \frac{4}{\pi} \cdot \frac{A}{R}$$

Baseband and audio interface for GSM

PCF50732

18.8 Typical output loads

Figure 13 illustrates the typical loads for the outputs: AUXDAC1, AUXDAC2, AUXDAC3, EARP, EARN, AUXSP and BUZ.

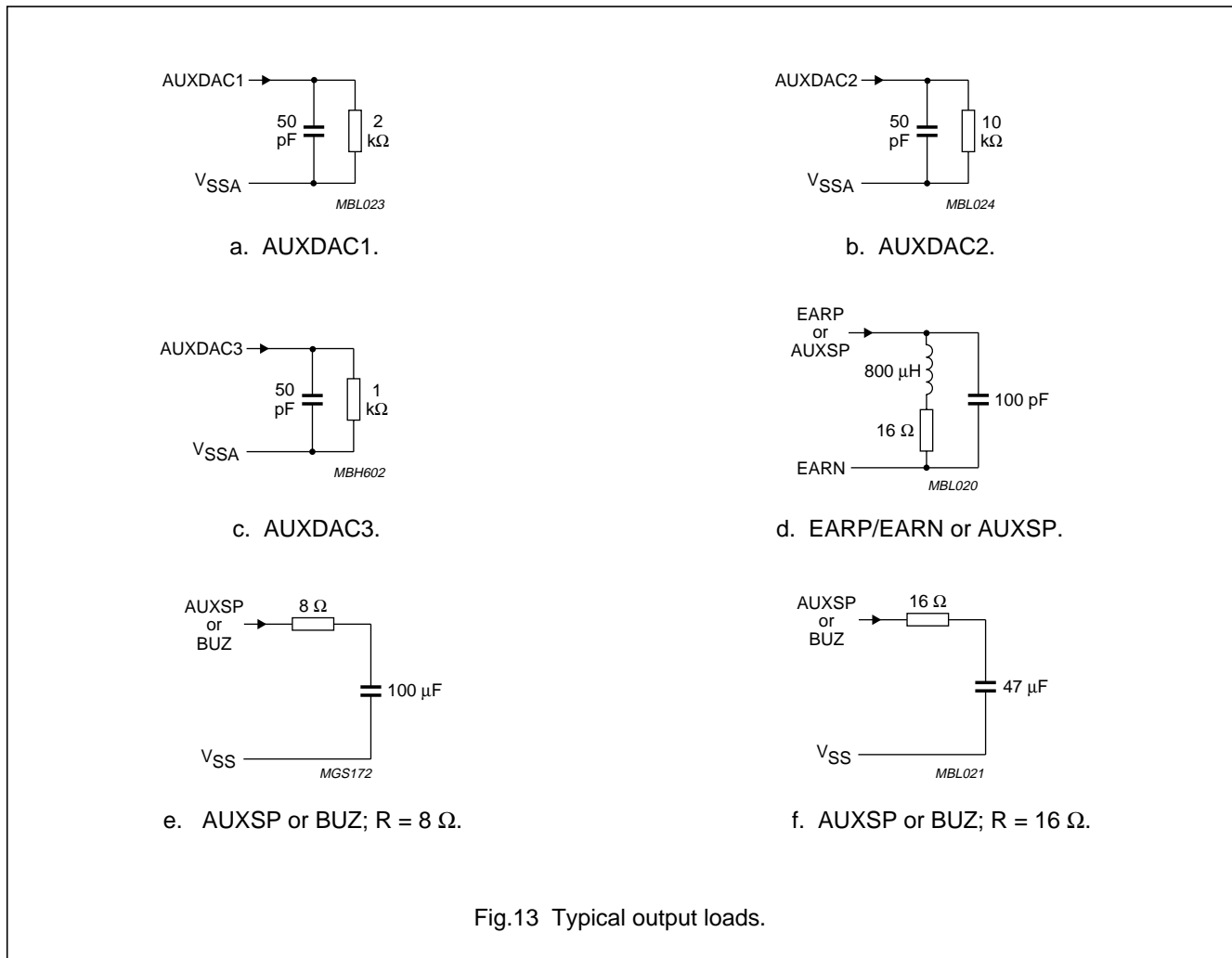
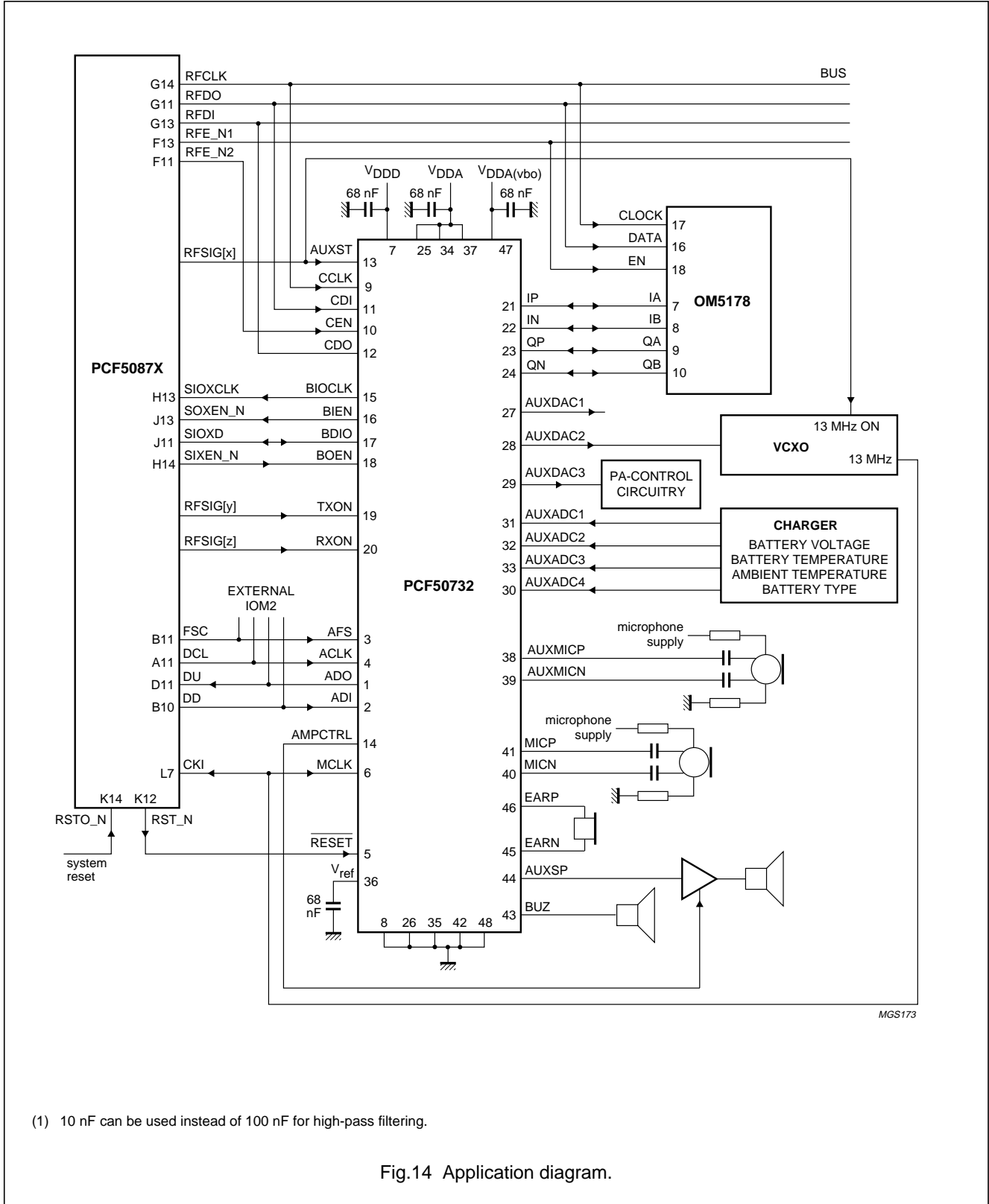

Fig.13 Typical output loads.

Baseband and audio interface for GSM

PCF50732

19 APPLICATION INFORMATION



(1) 10 nF can be used instead of 100 nF for high-pass filtering.

Fig.14 Application diagram.

Baseband and audio interface for GSM

PCF50732

19.1 Wake-up procedure from Sleep mode

Apart from being the status control signal of AUXDAC1, AUXDAC2 and the MCLK input, AUXST also starts a down-counter at each rising edge which controls the output drive capability of pin  $V_{ref}$ . This is important for the following considerations. For current consumption reduction during Sleep mode there are **two** possibilities as shown in Section 19.1.1 and 19.1.2.

19.1.1 POSSIBILITY 1

Program every block into power-down via CSI except for the band gap, then pull AUXST LOW to switch off the clock internally. This results in a  $I_{DD(total)} = 60 \mu A$  (typical). Since the band gap hasn't been programmed into power-down, the only active reference is  $V_{ref}$ . After a rising edge of AUXST,  $POST_{DAC}$  is in the order of 1.5 ms.

19.1.2 POSSIBILITY 2

If AUXST is also used to switch off the analog power supply, all references are shut down. The power-up time in this case is measured from the point where the MCLK clock input has valid levels or  $V_{DDA}$  has settled to its final value (the latter of the two signals sets the reference point).

A down-counter increases the band gap output drive capability for 32768 MCLK cycles which equals approximately 2.5 ms. After that time the voltage at  $V_{ref}$  has reached  $\pm 0.5$  mV of its final value. The timing diagram illustrates the situation (see Fig.15). Other points to note for this possibility:

- As long as  $V_{DDD}$  is not switched off, all registers keep their values.
- As long as  $V_{DDA(bb)}$  is not stable, the internal master clock is not running, because the first stage of the clock generator is supplied by  $V_{DDA}$ .
- All digital signals **MUST** remain stable for  $t_{MCLK}$  after AUXST has gone HIGH. This is necessary to avoid any timing violations in the digital part of the PCF50732 caused by an unstable MCLK clock input.
- The previously mentioned 2.5 ms for  $t_{BG}$  are only valid for  $C_{Vref} = 68 \text{ nF} \pm 10\%$  or less. The maximum of value 68 nF is highly recommended for good noise and power supply rejection figures.

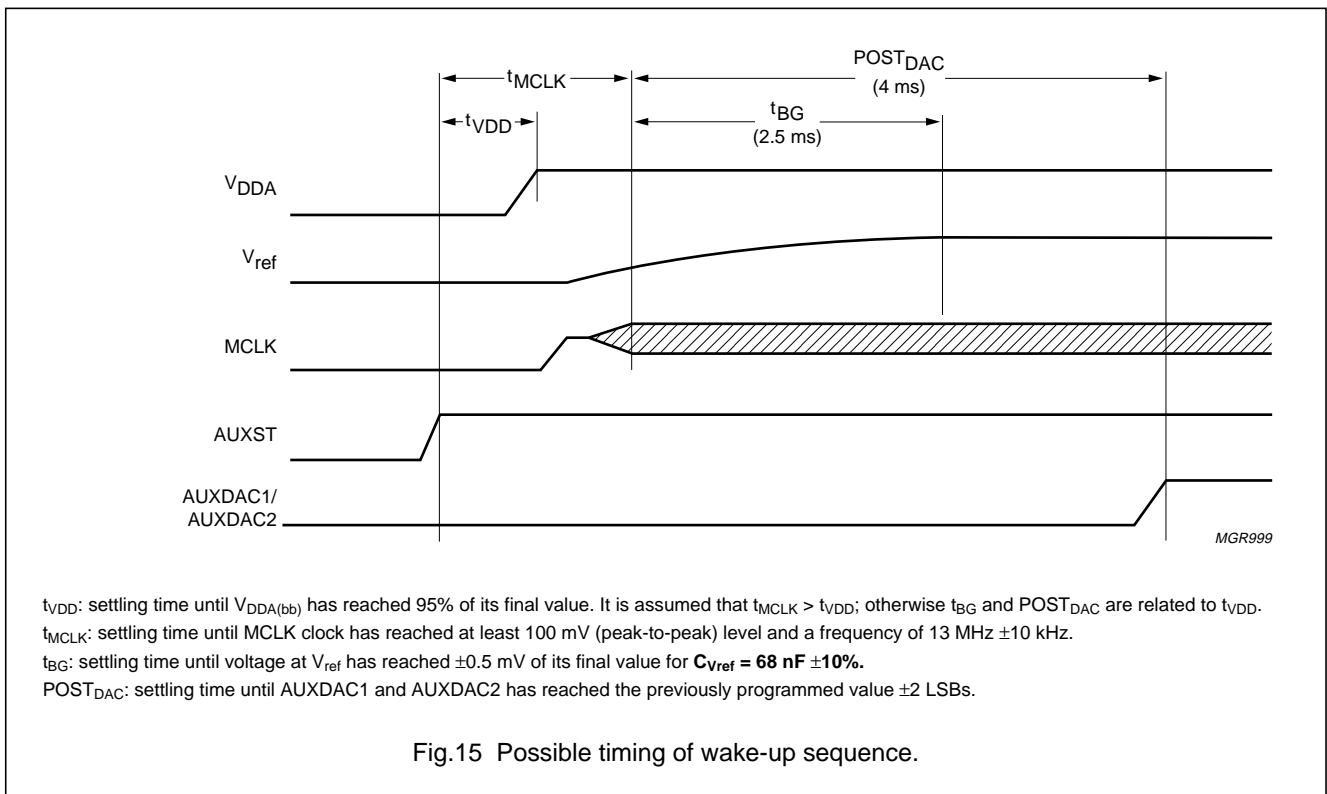



Baseband and audio interface for GSM

PCF50732

19.2 Microphone input connection and test set-up

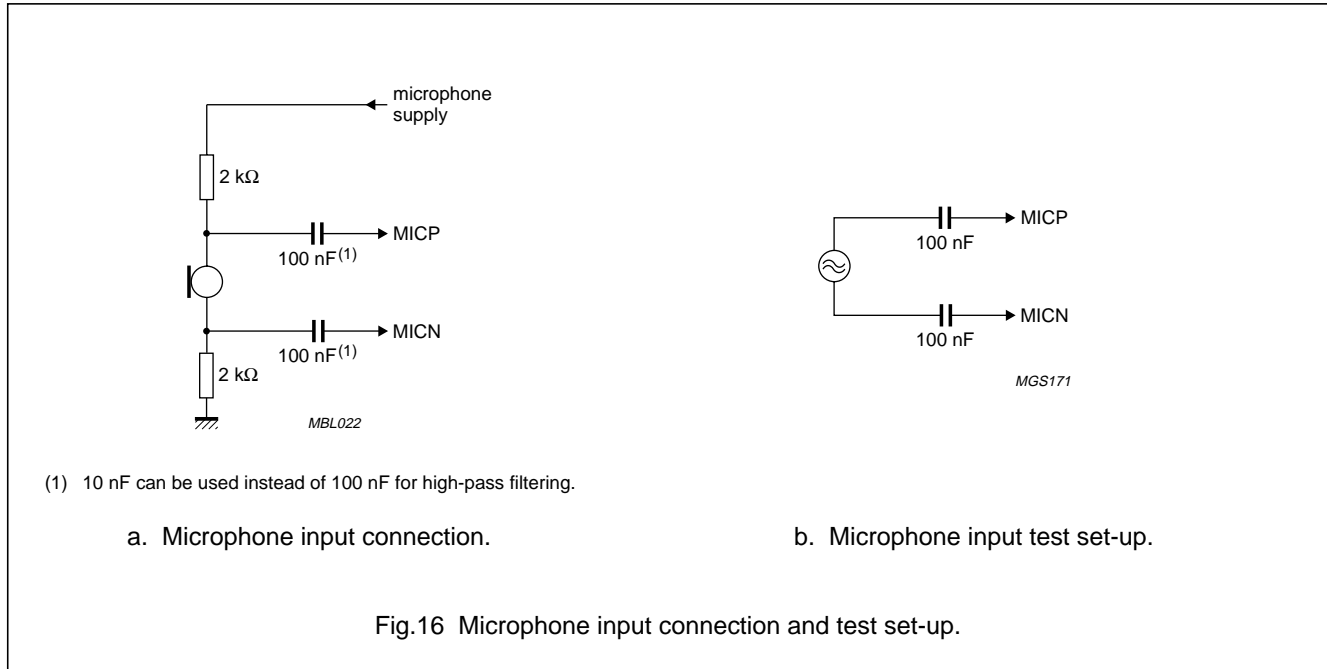

Baseband and audio interface for GSM

PCF50732

20 PACKAGE OUTLINE

LQFP48: plastic low profile quad flat package; 48 leads; body 7 x 7 x 1.4 mm

SOT313-2

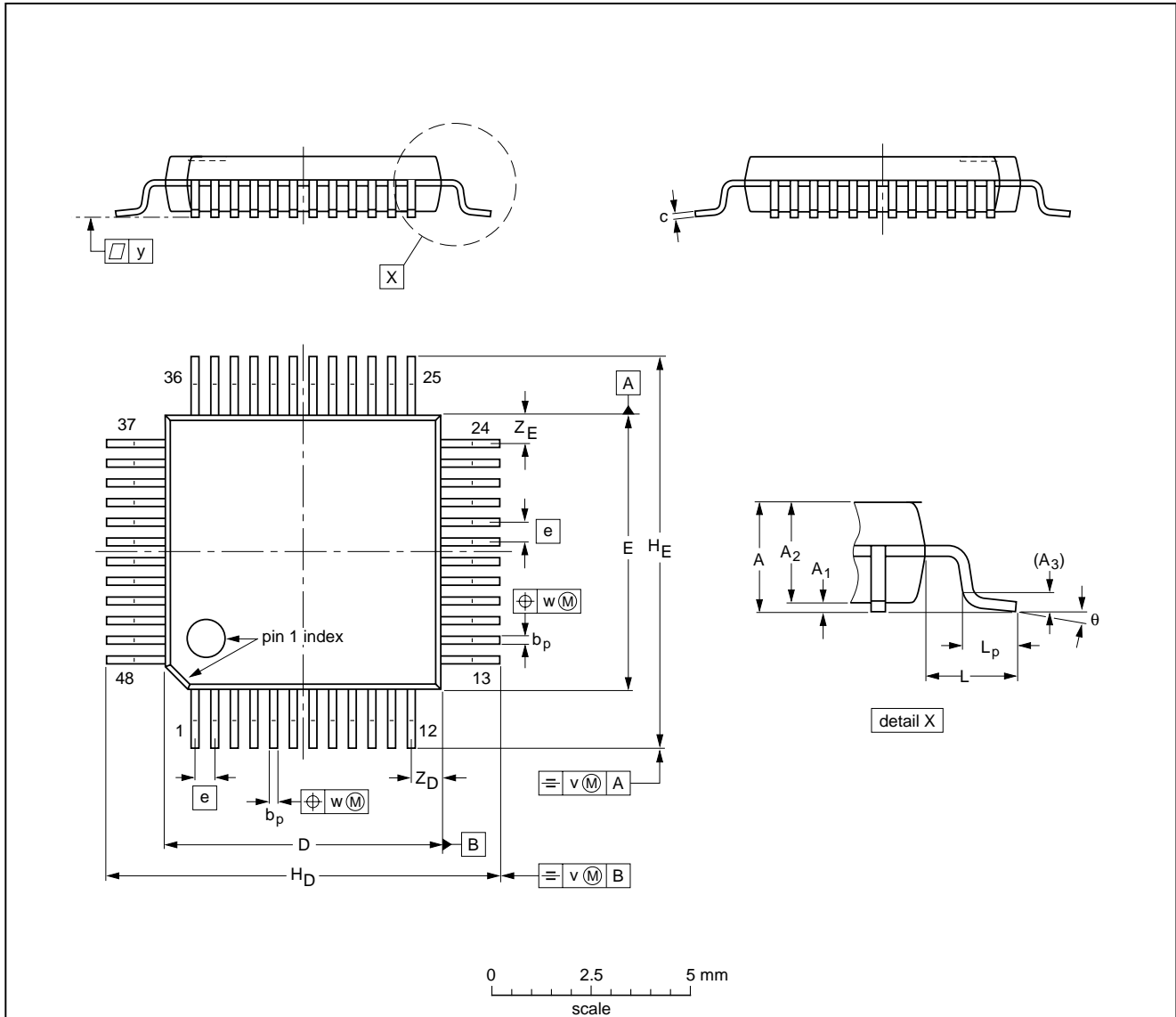

DIMENSIONS (mm are the original dimensions)

UNIT	A max.	A <sub>1</sub>	A <sub>2</sub>	A <sub>3</sub>	b <sub>p</sub>	c	D <sup>(1)</sup>	E <sup>(1)</sup>	e	H <sub>D</sub>	H <sub>E</sub>	L	L <sub>p</sub>	v	w	y	Z <sub>D</sub> <sup>(1)</sup>	Z <sub>E</sub> <sup>(1)</sup>	θ
mm	1.60	0.20 0.05	1.45 1.35	0.25	0.27 0.17	0.18 0.12	7.1 6.9	7.1 6.9	0.5	9.15 8.85	9.15 8.85	1.0	0.75 0.45	0.2	0.12	0.1	0.95 0.55	0.95 0.55	7° 0°

Note

1. Plastic or metal protrusions of 0.25 mm maximum per side are not included.

OUTLINE VERSION	REFERENCES				EUROPEAN PROJECTION	ISSUE DATE
	IEC	JEDEC	EIAJ			
SOT313-2						94-12-19 97-08-01

## Baseband and audio interface for GSM

## PCF50732

### 21 SOLDERING

#### 21.1 Introduction to soldering surface mount packages

This text gives a very brief insight to a complex technology. A more in-depth account of soldering ICs can be found in our *"Data Handbook IC26; Integrated Circuit Packages"* (document order number 9398 652 90011).

There is no soldering method that is ideal for all surface mount IC packages. Wave soldering is not always suitable for surface mount ICs, or for printed-circuit boards with high population densities. In these situations reflow soldering is often used.

#### 21.2 Reflow soldering

Reflow soldering requires solder paste (a suspension of fine solder particles, flux and binding agent) to be applied to the printed-circuit board by screen printing, stencilling or pressure-syringe dispensing before package placement.

Several methods exist for reflowing; for example, infrared/convection heating in a conveyor type oven. Throughput times (preheating, soldering and cooling) vary between 100 and 200 seconds depending on heating method.

Typical reflow peak temperatures range from 215 to 250 °C. The top-surface temperature of the packages should preferably be kept below 230 °C.

#### 21.3 Wave soldering

Conventional single wave soldering is not recommended for surface mount devices (SMDs) or printed-circuit boards with a high component density, as solder bridging and non-wetting can present major problems.

To overcome these problems the double-wave soldering method was specifically developed.

If wave soldering is used the following conditions must be observed for optimal results:

- Use a double-wave soldering method comprising a turbulent wave with high upward pressure followed by a smooth laminar wave.
- For packages with leads on two sides and a pitch (e):
  - larger than or equal to 1.27 mm, the footprint longitudinal axis is **preferred** to be parallel to the transport direction of the printed-circuit board;
  - smaller than 1.27 mm, the footprint longitudinal axis **must** be parallel to the transport direction of the printed-circuit board.

The footprint must incorporate solder thieves at the downstream end.

- For packages with leads on four sides, the footprint must be placed at a 45° angle to the transport direction of the printed-circuit board. The footprint must incorporate solder thieves downstream and at the side corners.

During placement and before soldering, the package must be fixed with a droplet of adhesive. The adhesive can be applied by screen printing, pin transfer or syringe dispensing. The package can be soldered after the adhesive is cured.

Typical dwell time is 4 seconds at 250 °C.

A mildly-activated flux will eliminate the need for removal of corrosive residues in most applications.

#### 21.4 Manual soldering

Fix the component by first soldering two diagonally-opposite end leads. Use a low voltage (24 V or less) soldering iron applied to the flat part of the lead. Contact time must be limited to 10 seconds at up to 300 °C.

When using a dedicated tool, all other leads can be soldered in one operation within 2 to 5 seconds between 270 and 320 °C.

## Baseband and audio interface for GSM

PCF50732

## 21.5 Suitability of surface mount IC packages for wave and reflow soldering methods

PACKAGE	SOLDERING METHOD	
	WAVE	REFLOW <sup>(1)</sup>
BGA, SQFP	not suitable	suitable
HLQFP, HSQFP, HSOP, HTSSOP, SMS	not suitable <sup>(2)</sup>	suitable
PLCC <sup>(3)</sup> , SO, SOJ	suitable	suitable
LQFP, QFP, TQFP	not recommended <sup>(3)(4)</sup>	suitable
SSOP, TSSOP, VSO	not recommended <sup>(5)</sup>	suitable

## Notes

- All surface mount (SMD) packages are moisture sensitive. Depending upon the moisture content, the maximum temperature (with respect to time) and body size of the package, there is a risk that internal or external package cracks may occur due to vaporization of the moisture in them (the so called popcorn effect). For details, refer to the Drypack information in the "Data Handbook IC26; Integrated Circuit Packages; Section: Packing Methods".
- These packages are not suitable for wave soldering as a solder joint between the printed-circuit board and heatsink (at bottom version) can not be achieved, and as solder may stick to the heatsink (on top version).
- If wave soldering is considered, then the package must be placed at a 45° angle to the solder wave direction. The package footprint must incorporate solder thieves downstream and at the side corners.
- Wave soldering is only suitable for LQFP, TQFP and QFP packages with a pitch (e) equal to or larger than 0.8 mm; it is definitely not suitable for packages with a pitch (e) equal to or smaller than 0.65 mm.
- Wave soldering is only suitable for SSOP and TSSOP packages with a pitch (e) equal to or larger than 0.65 mm; it is definitely not suitable for packages with a pitch (e) equal to or smaller than 0.5 mm.

## 22 DEFINITIONS

Data sheet status	
Objective specification	This data sheet contains target or goal specifications for product development.
Preliminary specification	This data sheet contains preliminary data; supplementary data may be published later.
Product specification	This data sheet contains final product specifications.
Limiting values	
Limiting values given are in accordance with the Absolute Maximum Rating System (IEC 134). Stress above one or more of the limiting values may cause permanent damage to the device. These are stress ratings only and operation of the device at these or at any other conditions above those given in the Characteristics sections of the specification is not implied. Exposure to limiting values for extended periods may affect device reliability.	
Application information	
Where application information is given, it is advisory and does not form part of the specification.	

## 23 LIFE SUPPORT APPLICATIONS

These products are not designed for use in life support appliances, devices, or systems where malfunction of these products can reasonably be expected to result in personal injury. Philips customers using or selling these products for use in such applications do so at their own risk and agree to fully indemnify Philips for any damages resulting from such improper use or sale.

Baseband and audio interface for GSM

PCF50732

---

**NOTES**

Baseband and audio interface for GSM

PCF50732

---

**NOTES**

Baseband and audio interface for GSM

PCF50732

---

**NOTES**

# Philips Semiconductors – a worldwide company

**Argentina:** see South America

**Australia:** 34 Waterloo Road, NORTH RYDE, NSW 2113,  
Tel. +61 2 9805 4455, Fax. +61 2 9805 4466

**Austria:** Computerstr. 6, A-1101 WIEN, P.O. Box 213,  
Tel. +43 1 60 101 1248, Fax. +43 1 60 101 1210

**Belarus:** Hotel Minsk Business Center, Bld. 3, r. 1211, Volodarski Str. 6,  
220050 MINSK, Tel. +375 172 20 0733, Fax. +375 172 20 0773

**Belgium:** see The Netherlands

**Brazil:** see South America

**Bulgaria:** Philips Bulgaria Ltd., Energoproject, 15th floor,  
51 James Bourchier Blvd., 1407 SOFIA,  
Tel. +359 2 68 9211, Fax. +359 2 68 9102

**Canada:** PHILIPS SEMICONDUCTORS/COMPONENTS,  
Tel. +1 800 234 7381, Fax. +1 800 943 0087

**China/Hong Kong:** 501 Hong Kong Industrial Technology Centre,  
72 Tat Chee Avenue, Kowloon Tong, HONG KONG,  
Tel. +852 2319 7888, Fax. +852 2319 7700

**Colombia:** see South America

**Czech Republic:** see Austria

**Denmark:** Sydhavnsgade 23, 1780 COPENHAGEN V,  
Tel. +45 33 29 3333, Fax. +45 33 29 3905

**Finland:** Sinikalliontie 3, FIN-02630 ESPOO,  
Tel. +358 9 615 800, Fax. +358 9 6158 0920

**France:** 51 Rue Carnot, BP317, 92156 SURESNES Cedex,  
Tel. +33 1 4099 6161, Fax. +33 1 4099 6427

**Germany:** Hammerbrookstraße 69, D-20097 HAMBURG,  
Tel. +49 40 2353 60, Fax. +49 40 2353 6300

**Hungary:** see Austria

**India:** Philips INDIA Ltd, Band Box Building, 2nd floor,  
254-D, Dr. Annie Besant Road, Worli, MUMBAI 400 025,  
Tel. +91 22 493 8541, Fax. +91 22 493 0966

**Indonesia:** PT Philips Development Corporation, Semiconductors Division,  
Gedung Philips, Jl. Buncit Raya Kav.99-100, JAKARTA 12510,  
Tel. +62 21 794 0040 ext. 2501, Fax. +62 21 794 0080

**Ireland:** Newstead, Clonskeagh, DUBLIN 14,  
Tel. +353 1 7640 000, Fax. +353 1 7640 200

**Israel:** RAPAC Electronics, 7 Kehilat Saloniki St, PO Box 18053,  
TEL AVIV 61180, Tel. +972 3 645 0444, Fax. +972 3 649 1007

**Italy:** PHILIPS SEMICONDUCTORS, Piazza IV Novembre 3,  
20124 MILANO, Tel. +39 2 6752 2531, Fax. +39 2 6752 2557

**Japan:** Philips Bldg 13-37, Kohnan 2-chome, Minato-ku,  
TOKYO 108-8507, Tel. +81 3 3740 5130, Fax. +81 3 3740 5077

**Korea:** Philips House, 260-199 Itaewon-dong, Yongsan-ku, SEOUL,  
Tel. +82 2 709 1412, Fax. +82 2 709 1415

**Malaysia:** No. 76 Jalan Universiti, 46200 PETALING JAYA, SELANGOR,  
Tel. +60 3 750 5214, Fax. +60 3 757 4880

**Mexico:** 5900 Gateway East, Suite 200, EL PASO, TEXAS 79905,  
Tel. +9-5 800 234 7381, Fax +9-5 800 943 0087

**Middle East:** see Italy

**Netherlands:** Postbus 90050, 5600 PB EINDHOVEN, Bldg. VB,  
Tel. +31 40 27 82785, Fax. +31 40 27 88399

**New Zealand:** 2 Wagener Place, C.P.O. Box 1041, AUCKLAND,  
Tel. +64 9 849 4160, Fax. +64 9 849 7811

**Norway:** Box 1, Manglerud 0612, OSLO,  
Tel. +47 22 74 8000, Fax. +47 22 74 8341

**Pakistan:** see Singapore

**Philippines:** Philips Semiconductors Philippines Inc.,  
106 Valero St. Salcedo Village, P.O. Box 2108 MCC, MAKATI,  
Metro MANILA, Tel. +63 2 816 6380, Fax. +63 2 817 3474

**Poland:** Ul. Lukiska 10, PL 04-123 WARSZAWA,  
Tel. +48 22 612 2831, Fax. +48 22 612 2327

**Portugal:** see Spain

**Romania:** see Italy

**Russia:** Philips Russia, Ul. Usatcheva 35A, 119048 MOSCOW,  
Tel. +7 095 755 6918, Fax. +7 095 755 6919

**Singapore:** Lorong 1, Toa Payoh, SINGAPORE 319762,  
Tel. +65 350 2538, Fax. +65 251 6500

**Slovakia:** see Austria

**Slovenia:** see Italy

**South Africa:** S.A. PHILIPS Pty Ltd., 195-215 Main Road Martindale,  
2092 JOHANNESBURG, P.O. Box 7430 Johannesburg 2000,  
Tel. +27 11 470 5911, Fax. +27 11 470 5494

**South America:** Al. Vicente Pinzon, 173, 6th floor,  
04547-130 SÃO PAULO, SP, Brazil,  
Tel. +55 11 821 2333, Fax. +55 11 821 2382

**Spain:** Balmes 22, 08007 BARCELONA,  
Tel. +34 93 301 6312, Fax. +34 93 301 4107

**Sweden:** Kottbygatan 7, Akalla, S-16485 STOCKHOLM,  
Tel. +46 8 5985 2000, Fax. +46 8 5985 2745

**Switzerland:** Allmendstrasse 140, CH-8027 ZÜRICH,  
Tel. +41 1 488 2741 Fax. +41 1 488 3263

**Taiwan:** Philips Semiconductors, 6F, No. 96, Chien Kuo N. Rd., Sec. 1,  
TAIPEI, Taiwan Tel. +886 2 2134 2886, Fax. +886 2 2134 2874

**Thailand:** PHILIPS ELECTRONICS (THAILAND) Ltd.,  
209/2 Sanpavuth-Bangna Road Prakanong, BANGKOK 10260,  
Tel. +66 2 745 4090, Fax. +66 2 398 0793

**Turkey:** Talatpasa Cad. No. 5, 80640 GÜLTEPE/ISTANBUL,  
Tel. +90 212 279 2770, Fax. +90 212 282 6707

**Ukraine:** PHILIPS UKRAINE, 4 Patrice Lumumba str., Building B, Floor 7,  
252042 KIEV, Tel. +380 44 264 2776, Fax. +380 44 268 0461

**United Kingdom:** Philips Semiconductors Ltd., 276 Bath Road, Hayes,  
MIDDLESEX UB3 5BX, Tel. +44 181 730 5000, Fax. +44 181 754 8421

**United States:** 811 East Arques Avenue, SUNNYVALE, CA 94088-3409,  
Tel. +1 800 234 7381, Fax. +1 800 943 0087

**Uruguay:** see South America

**Vietnam:** see Singapore

**Yugoslavia:** PHILIPS, Trg N. Pasica 5/v, 11000 BEOGRAD,  
Tel. +381 11 62 5344, Fax. +381 11 63 5777

**For all other countries apply to:** Philips Semiconductors,  
International Marketing & Sales Communications, Building BE-p, P.O. Box 218,  
5600 MD EINDHOVEN, The Netherlands, Fax. +31 40 27 24825

**Internet:** <http://www.semiconductors.philips.com>

© Philips Electronics N.V. 1999

SCA63

All rights are reserved. Reproduction in whole or in part is prohibited without the prior written consent of the copyright owner.

The information presented in this document does not form part of any quotation or contract, is believed to be accurate and reliable and may be changed without notice. No liability will be accepted by the publisher for any consequence of its use. Publication thereof does not convey nor imply any license under patent- or other industrial or intellectual property rights.

Printed in The Netherlands

465008/00/01/pp64

Date of release: 1999 May 03

Document order number: 9397 750 04998

*Let's make things better.*

**Philips  
Semiconductors**



**PHILIPS**