

MONOLITHIC CD-ROM 3-PHASE SPINDLE MOTOR DRIVER

The μ PD16856 is a CD-ROM 3-phase spindle motor driver consisting of a CMOS controller and MOS bridge outputs.

By employing 3-phase full-wave PWM as the drive method and MOS FETs at the output stage, it has been possible to reduce the power consumption of the μ PD16856 ever further than the conventional linear drive drivers that use bipolar transistors.

By using a 30-pin shrink SOP package, a more compact-size has been achieved.

FEATURES

- Supply voltage for controller block: 5 V, supply voltage for output block: 12 V
3 V input available for the input interface
- Low on-state resistance (total on-state resistance of upper and lower MOS FETs) $R_{ON} = 1.3 \Omega$ (TYP.)
- Low power consumption due to 3-phase full-wave PWM drive method
- On-chip hole bias switch (linked with STB pin)
- On-chip IND (FG) pulse switching function, 1-phase output or 3-phase composite output
- START/STOP pin included, acting as a brake during STOP
- Standby pins included, turning off internal circuit in standby
- Low current consumption: $I_{DD} = 3 \text{ mA}$ (Max.), $I_{DD(ST)} = 1 \mu\text{A}$ (Max.)
- On-chip thermal shutdown circuit
- On-chip current limiting circuit; reference voltage can be set externally
- On-chip low voltage malfunction prevention circuit
- On-chip reverse rotation prevention circuit
- 30-pin plastic shrink SOP (300 mil)

ORDERING INFORMATION

Part Number	Package
μ PD16856GS	30-pin shrink SOP (0.8-mm pitch, 300 mil)

The information in this document is subject to change without notice.

ABSOLUTE MAXIMUM RATINGS (T_A = 25°C)

Parameter	Symbol	Conditions	Ratings	Unit
Supply voltage	V _{DD}		-0.5 to +6.0	V
	V _M		-0.5 to +13.5	V
Input voltage	V _{IN}		-0.5 to V _{DD} + 0.5	V
Instantaneous output current ^{Note 1}	I _{DR (pulse)}	PW ≤ 5 ms, Duty ≤ 30%	±2.0	A/phase
Power consumption ^{Note 2}	P _T		1.0	W
Peak channel temperature	T _{CH (MAX)}		150	°C
Storage temperature range	T _{stg}		-55 to +150	°C

Notes 1. Allowable current per phase while on-board

2. When mounted on glass epoxy board (100 mm × 100 mm × 1 mm)

RECOMMENDED OPERATING RANGE

Parameter	Symbol	Conditions	MIN.	TYP.	MAX.	Unit
Supply voltage	V _{DD}		4.5	5.0	5.5	V
	V _M		10.8	12.0	13.2	V
Output current (DC)	I _{DR (DC)}				±0.5	A/Phase
Instantaneous output current	I _{DR (pulse)}	PW ≤ 5 ms, Duty ≤ 10%			±1.5	A/Phase
Hole bias current	I _{HB}			10	15	mA
IND pin output current	I _{FG}		0	±2.5	±5	mA
CL pin input voltage	V _{CL}		0.1		0.4	V
Operating temperature range	T _A		-20		75	°C

ELECTRICAL SPECIFICATIONS (UNLESS OTHERWISE SPECIFIED, T_A = 25°C, V_{DD} = 5 V, V_M = 12 V)

Parameter	Symbol	Conditions	MIN.	TYP.	MAX.	Unit
[General]						
Current consumption 1 (during operation)	I _{DD}	STB = V _{DD}		1.5	3.0	mA
Current consumption (in standby)	I _{DD (ST)}	STB = GND			1.0	μA
[ST/SP, STB, REV, FGsel]						
Input voltage, high	V _{IH}		1.8		V _{DD}	V
Input voltage, low	V _{IL}				0.8	V
Input pull-down resistor	R _{IND}			120		kΩ
[Controller block]						
Triangle wave oscillation frequency	f _{PWM}	C _T = 100 pF		75		kHz
[Hole amplifier]						
Common mode input voltage range	V _{Hch}		1.0		3.5	V
Hysteresis voltage	V _{Hhys}	V _H = 2.5 V		15		mV
Input bias current	I _{Hbias}				1.0	μA
[Hole bias block]						
Hole bias voltage	V _{HB}	I _{HB} = 10 mA		0.3	0.5	V
[FG output]						
IND-pin voltage, high	V _{FG_H}	I _{FG} = -2.5 mA	4.0			V
IND-pin voltage, low	V _{FG_L}	I _{FG} = +2.5 mA			0.5	V
[Output block]						
Output on-state resistance (upper stage + lower stage)	R _{ON}	I _{DR} = 200 mA T _A = -20°C to +75°C		1.3	1.8	Ω
Leakage current during OFF	I _{DR (OFF)}	In standby			10	μA
Output turn-on time	t _{ONH}	R _M = 5 Ω		1.0	2.0	μs
Output turn-off time	t _{OFFH}	Star connection		1.0	2.0	μs
[Torque command]						
Control reference input voltage range	ECR		0.3		4.0	V
Control input voltage range	EC		0.3		4.0	V
Input current	I _{IN}			30	50	μA
Input voltage difference	ECR-EC ^{Note}	DUTY = 100%		1.0		V
Dead zone (+)	EC_d+	1.5 V ≤ ECR ≤ 2.5 V	0	50	100	mV
Dead zone (-)	EC_d-	1.5 V ≤ ECR ≤ 2.5 V	0	-50	-100	mV
[Overcurrent detection block]						
Input offset voltage	V _{IO}		-15		+15	mV

Note Dead zone not included.

- Remarks**
1. The thermal shutdown circuit (T.S.D.) operates with T_{CH} > 150°C.
 2. The low-voltage malfunction prevention circuit (UVLO) operates with a voltage of 4 V_{TYP}.

PIN FUNCTIONS

Package: 30-pin Shrink SOP (300 mil)

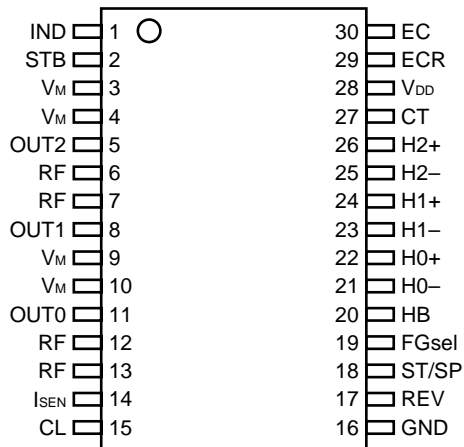

Pin No.	Pin Name	Pin Function
1	IND	Index signal output pin
2	STB	Standby operation input pin
3	V _M	Supply input pin for motor block (12 V)
4	V _M	Supply input pin for motor block (12 V)
5	OUT2	Motor connection pin
6	RF	3-phase bridge common pin
7	RF	3-phase bridge common pin
8	OUT1	Motor connection pin
9	V _M	Supply input pin for motor block (12 V)
10	V _M	Supply input pin for motor block (12 V)
11	OUT0	Motor connection pin
12	RF	3-phase bridge common pin
13	RF	3-phase bridge common pin
14	I _{SEN}	Sense resistor connection pin
15	CL	Overcurrent detection voltage input pin
16	GND	GND pin
17	REV	Reverse rotation input pin (reverse brake pin)
18	ST/SP	Start/stop input pin
19	FGsel	IND pulse selection pin
20	HB	Hole bias pin
21	H0-	Hole signal input pin
22	H0+	Hole signal input pin
23	H1-	Hole signal input pin
24	H1+	Hole signal input pin
25	H2-	Hole signal input pin
26	H2+	Hole signal input pin
27	CT	Oscillation frequency setup capacitor connection pin
28	V _{DD}	Controller block supply input pin (5 V)
29	ECR	Control reference voltage input pin
30	EC	Control voltage input pin

Caution When there is more than one pin of the same kind of pin (V_M and RF), all pins should be connected to their targets.

BLOCK DIAGRAM

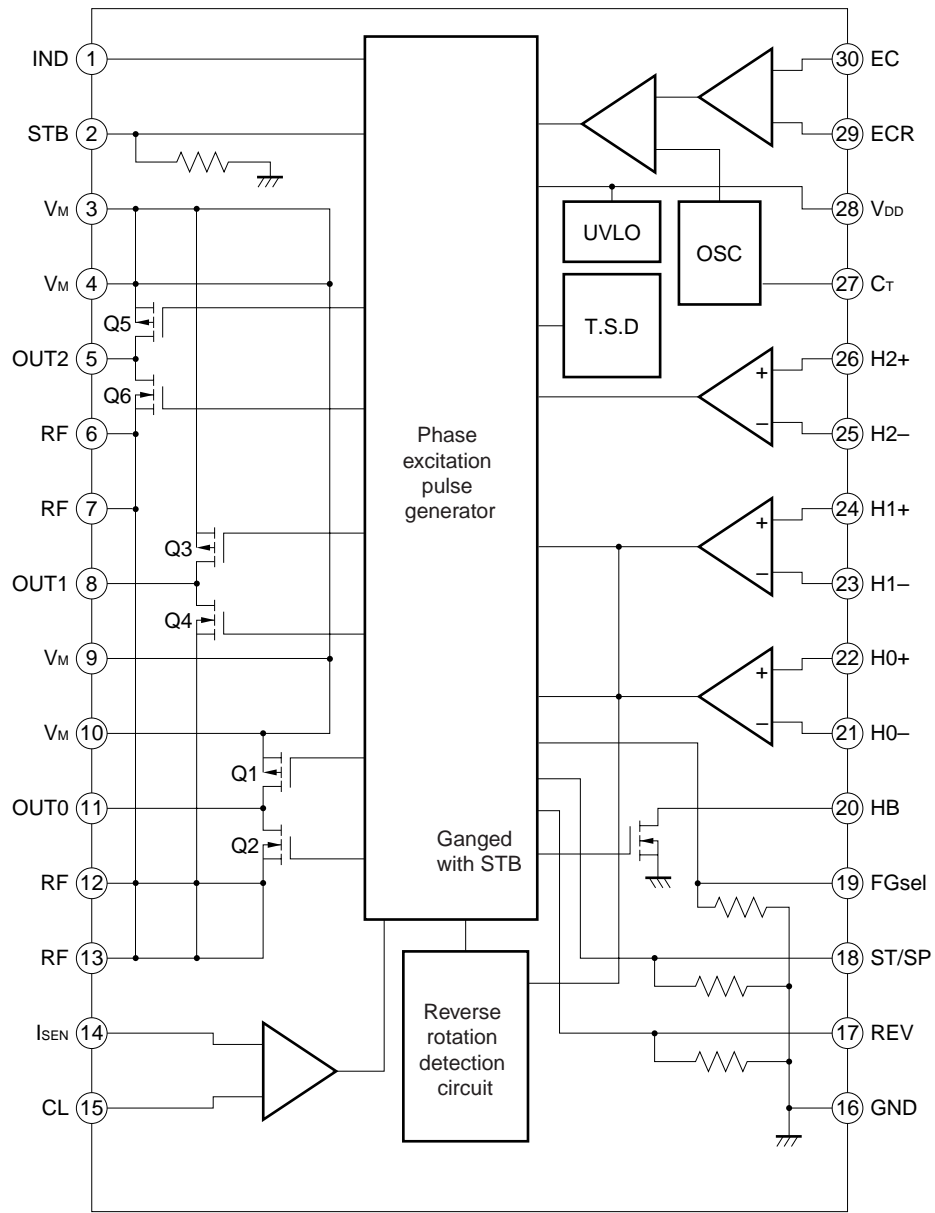

Caution When there is more than one pin of the same kind of pin (V_M and RF), all pins should be connected to their targets.

TOTAL POWER DISSIPATION VS. AMBIENT TEMPERATURE CHARACTERISTICS

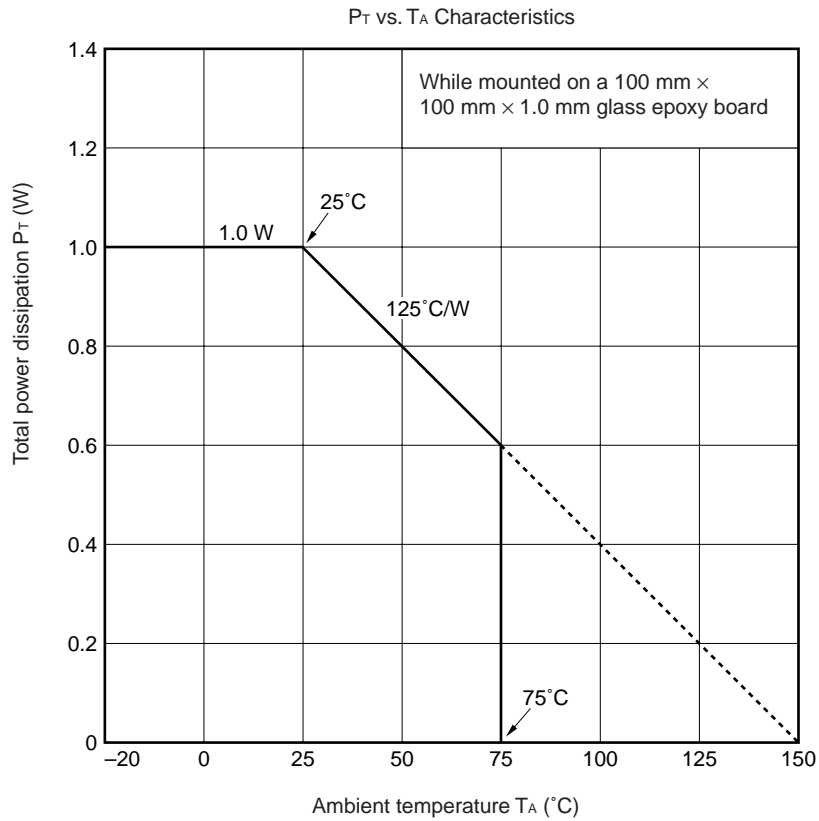

Remark It is possible to apply a maximum of 1 W of power when the ambient temperature is 25°C or lower. When the ambient temperature is higher than 25°C, derate based on the above chart. It is possible to apply 0.6 W to the IC when the ambient temperature is 75°C, which is within recommended ambient temperature conditions.

STANDARD CHARACTERISTICS CURVES (UNLESS OTHERWISE SPECIFIED, T_A = 25°C)

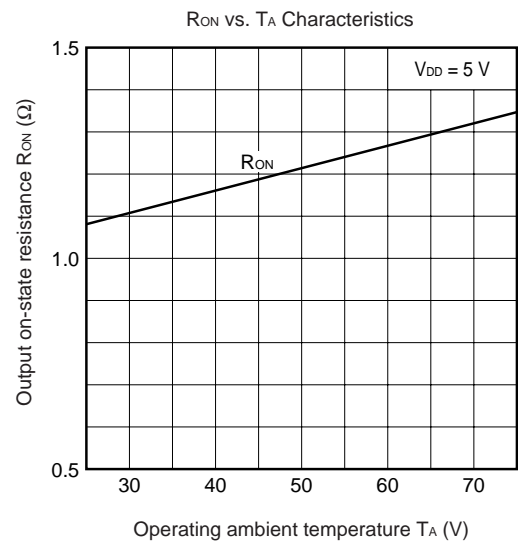
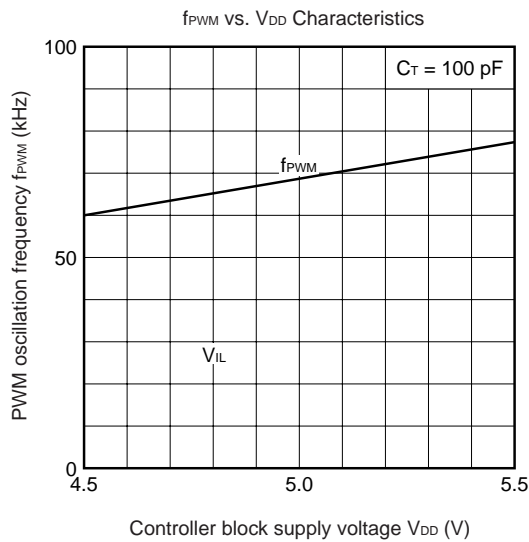
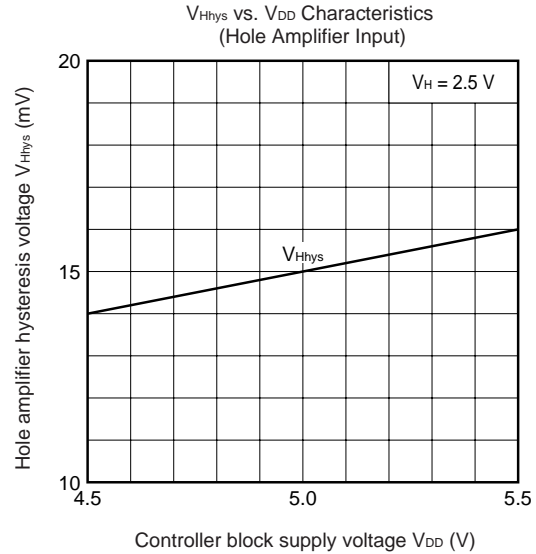
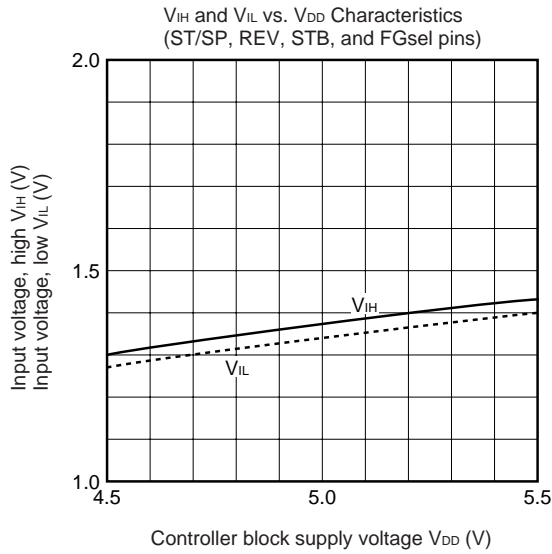
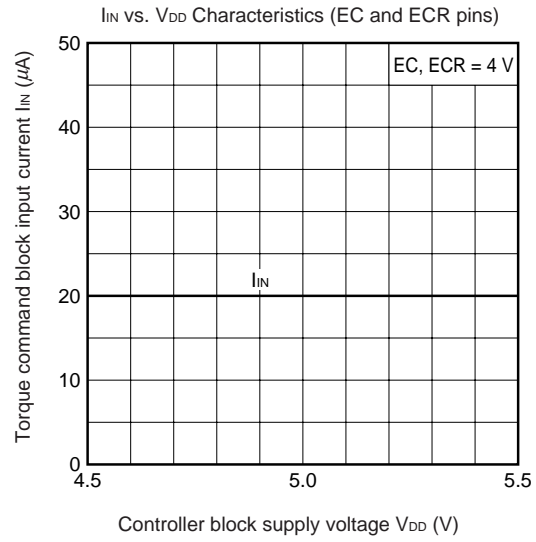
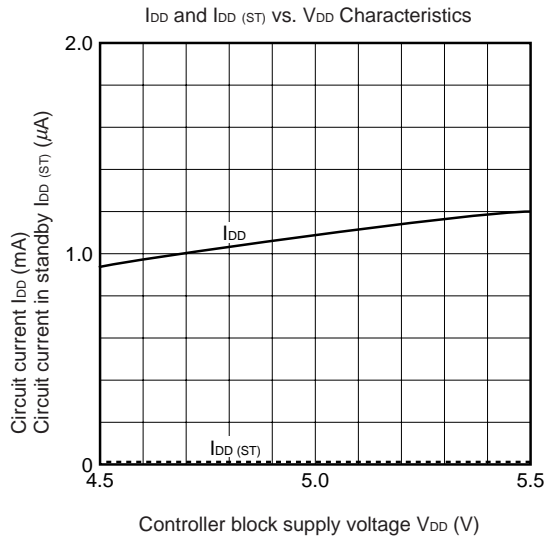

FUNCTION OPERATION TABLE

(1) ST/SP = “H”

Input Signal				Circuit Operation Mode	Source → Sink
CMP0	CMP1	CMP2	PWM		
H	H	L	H	Operation	W → V
H	H	L	L	Brake	
H	L	L	H	Operation	W → U
H	L	L	L	Brake	
H	L	H	H	Operation	V → U
H	L	H	L	Brake	
L	L	H	H	Operation	V → W
L	L	H	L	Brake	
L	H	H	H	Operation	U → W
L	H	H	L	Brake	
L	H	L	H	Operation	U → V
L	H	L	L	Brake	

Brake: Regenerates via the high-side Pch MOS FET channel.

(2) ST/SP = “L”

Input Signal				Circuit Operation Mode
CMP0	CMP1	CMP2	PWM	
-	-	-	-	Short brake

Short brake: Turns the high-side MOS FET on and the low-side MOS FET off.

(3) Torque Command

The curve shown below is the relationship to torque of the difference (ECR – EC) between the control reference voltage (ECR) and the control voltage (EC).

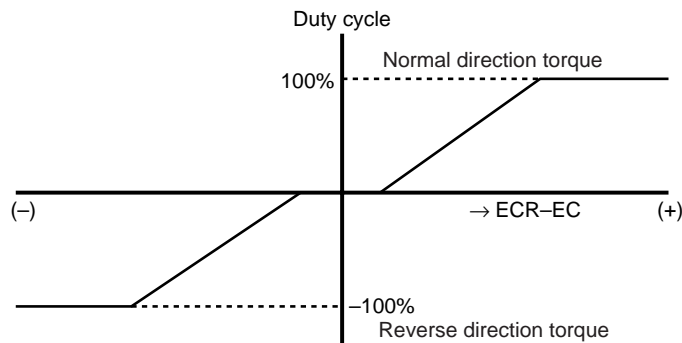

	Reverse Rotation Pin Voltage (REV)	
	L	H
ECR > EC	Normal rotation	Reverse rotation ^{Note}
ECR < EC	Reverse rotation ^{Note}	Stop

Note Stops after detecting reverse rotation
The reverse drive current flows in the high-side Pch MOS FET channel on reverse rotation.

(4) Standby Mode

The setting of the standby mode allows the power supply in the device to be turned off forcibly.

The status of outputs from pins in standby is high impedance (H-bridge all OFF). In addition it is possible to reduce the circuit current since the internal oscillation block stops.

When the stop operation is executed by the standby pin during normal operation, the motor is stopped by inertia force.

When the normal status is reset, it takes several tens of μ s to be activated.

STB Pin	Operation Mode
H	Normal operation mode
L	Standby mode

TIMING CHART

(1) Hole Signal Input

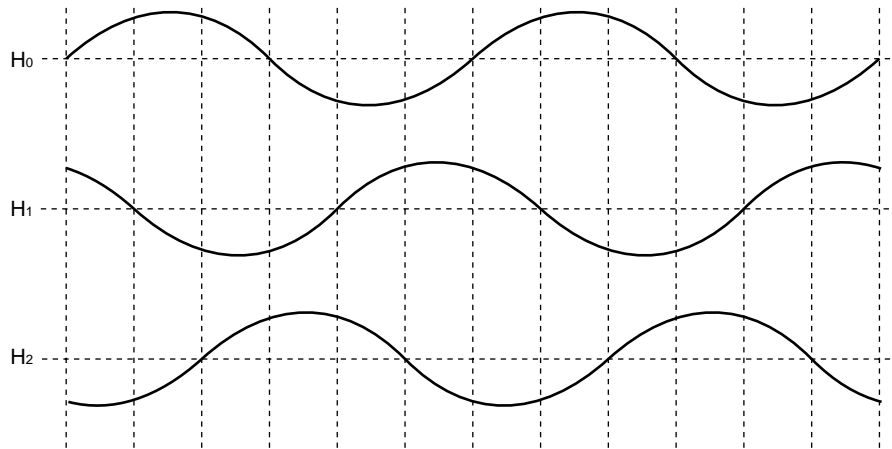

(2) CMP Signal (FGsel = L: IND1, FGsel = H: IND2)

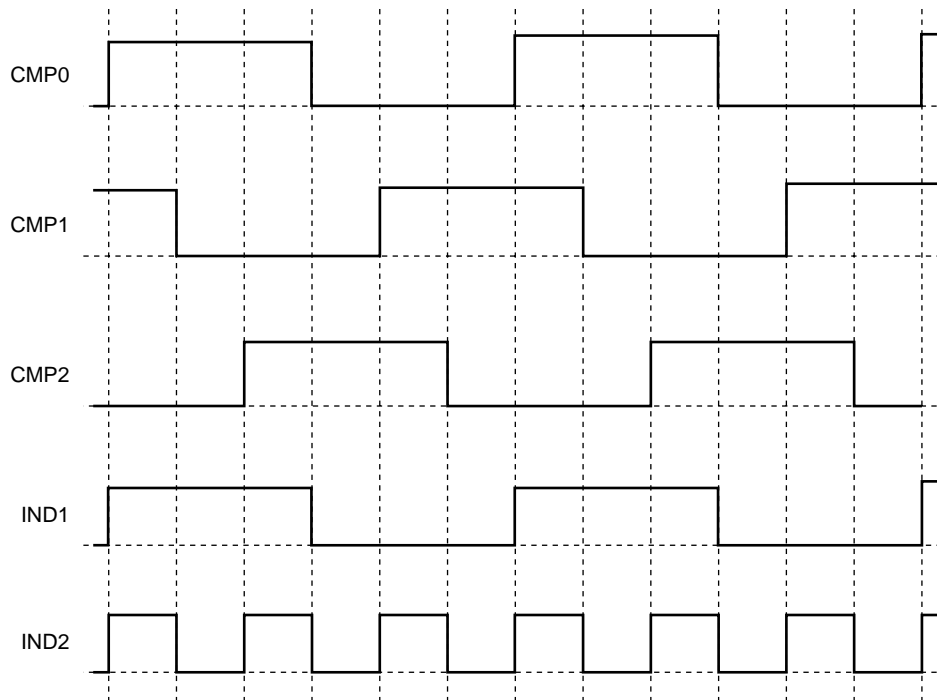

(3) Selection of Output MOS FET Drive and Comparator (A Blank Indicates Switch OFF)

Q1	\overline{SW}	SW		ON	ON		\overline{SW}	\overline{SW}		ON	ON		
Q2	SW	SW					SW	SW					
Q3	\overline{SW}		ON	ON		\overline{SW}	\overline{SW}		ON	ON		\overline{SW}	\overline{SW}
Q4	SW					SW	SW					SW	SW
Q5	ON	ON		\overline{SW}	\overline{SW}		ON	ON		\overline{SW}	\overline{SW}		ON
Q6				SW	SW					SW	SW		

(4) Motor Drive Waveform

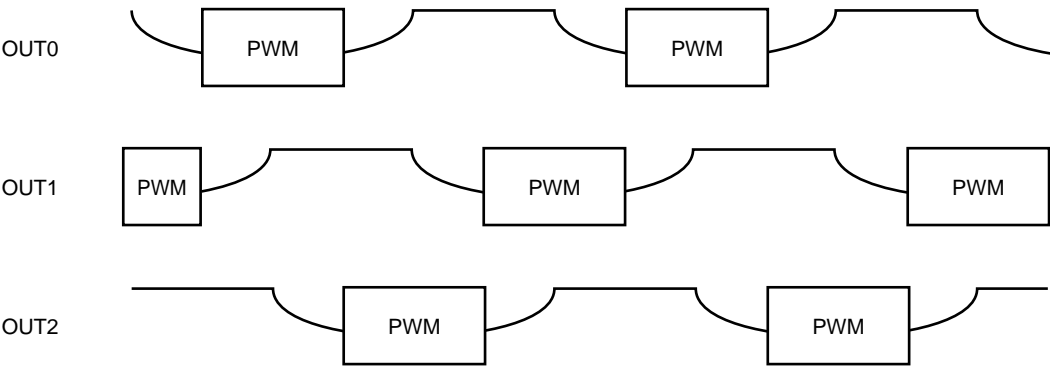

APPLICATION CIRCUIT EXAMPLE

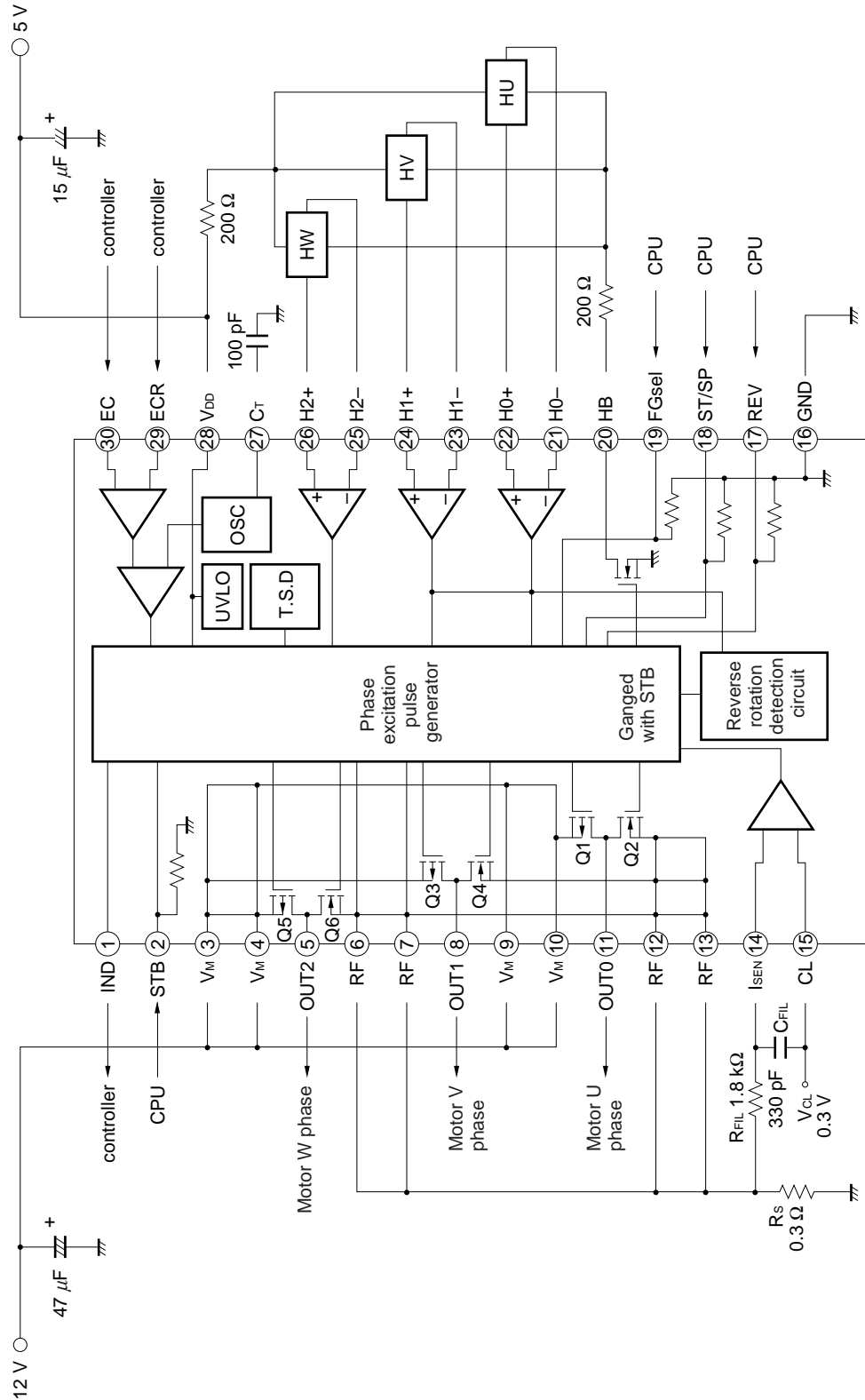

Remark To eliminate noise during PWM, it is recommended to insert a tantalum capacitor between VM and GND (47 μF in the above figure).
 Moreover, set V_{CL} and R_s to values within the ratings.
 This circuit is for reference only and is not intended for use in mass production.

PACKAGE DRAWING

30-Pin Plastic Shrink SOP (300 mil) (Unit: mm)

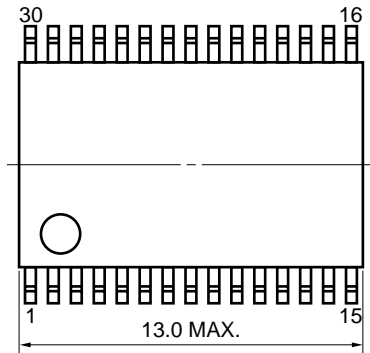

Detail of lead end

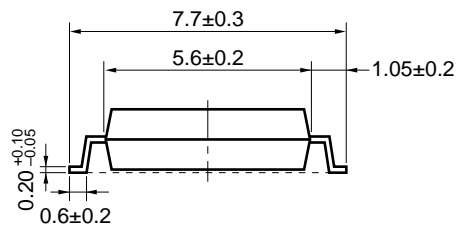
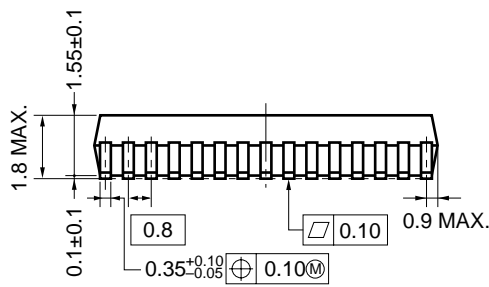
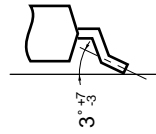

RECOMMENDED SOLDERING CONDITIONS

μPD16856 should be soldered and mounted under the following recommended conditions. For soldering methods and conditions other than those recommended below, contact your NEC sales representative.

- For the details of the recommended soldering conditions, refer to the document **Semiconductor Device Mounting Technology Manual (C10535E)**.

Soldering Method	Soldering Conditions	Recommended Condition Symbol
Infrared reflow	Package peak temperature: 235°C, Time: 30 sec. Max. (at 210°C or higher), Count: three times or less, Exposure limit: none ^{Note} , Flux: Rosin-based flux with little chlorine content (chlorine: 0.2 Wt% Max.) is recommended	IR35-00-3
VPS	Package peak temperature: 215°C, Time: 40 sec. Max. (at 200°C or higher), Count: three times or less, Exposure limit: none ^{Note} , Flux: Rosin-based flux with little chlorine content (chlorine: 0.2 Wt% Max.) is recommended	VP15-00-3
Wave soldering	Package peak temperature: 260°C, Time: 10 sec. Max., Proheating temperature: 120°C Max., Count: once, Flux: Rosin-based flux with little chlorine content (chlorine: 0.2 Wt% Max.) is recommended	WS60-00-1

Note After opening the dry pack, store it at 25°C or less and 65% RH or less for the allowable storage period.

Caution Do not use different soldering methods together.

Regional Information

Some information contained in this document may vary from country to country. Before using any NEC product in your application, please contact the NEC office in your country to obtain a list of authorized representatives and distributors. They will verify:

- Device availability
- Ordering information
- Product release schedule
- Availability of related technical literature
- Development environment specifications (for example, specifications for third-party tools and components, host computers, power plugs, AC supply voltages, and so forth)
- Network requirements

In addition, trademarks, registered trademarks, export restrictions, and other legal issues may also vary from country to country.

NEC Electronics Inc. (U.S.)

Santa Clara, California
Tel: 408-588-6000
800-366-9782
Fax: 408-588-6130
800-729-9288

NEC Electronics (Germany) GmbH

Duesseldorf, Germany
Tel: 0211-65 03 02
Fax: 0211-65 03 490

NEC Electronics (UK) Ltd.

Milton Keynes, UK
Tel: 01908-691-133
Fax: 01908-670-290

NEC Electronics Italiana s.r.l.

Milano, Italy
Tel: 02-66 75 41
Fax: 02-66 75 42 99

NEC Electronics (Germany) GmbH

Benelux Office
Eindhoven, The Netherlands
Tel: 040-2445845
Fax: 040-2444580

NEC Electronics (France) S.A.

Velizy-Villacoublay, France
Tel: 01-30-67 58 00
Fax: 01-30-67 58 99

NEC Electronics (France) S.A.

Spain Office
Madrid, Spain
Tel: 91-504-2787
Fax: 91-504-2860

NEC Electronics (Germany) GmbH

Scandinavia Office
Taeby, Sweden
Tel: 08-63 80 820
Fax: 08-63 80 388

NEC Electronics Hong Kong Ltd.

Hong Kong
Tel: 2886-9318
Fax: 2886-9022/9044

NEC Electronics Hong Kong Ltd.

Seoul Branch
Seoul, Korea
Tel: 02-528-0303
Fax: 02-528-4411

NEC Electronics Singapore Pte. Ltd.

United Square, Singapore 1130
Tel: 65-253-8311
Fax: 65-250-3583

NEC Electronics Taiwan Ltd.

Taipei, Taiwan
Tel: 02-2719-2377
Fax: 02-2719-5951

NEC do Brasil S.A.

Electron Devices Division
Rodovia Presidente Dutra, Km 214
07210-902-Guarulhos-SP Brasil
Tel: 55-11-6465-6810
Fax: 55-11-6465-6829

J99.1

No part of this document may be copied or reproduced in any form or by any means without the prior written consent of NEC Corporation. NEC Corporation assumes no responsibility for any errors which may appear in this document.

NEC Corporation does not assume any liability for infringement of patents, copyrights or other intellectual property rights of third parties by or arising from use of a device described herein or any other liability arising from use of such device. No license, either express, implied or otherwise, is granted under any patents, copyrights or other intellectual property rights of NEC Corporation or others.

While NEC Corporation has been making continuous effort to enhance the reliability of its semiconductor devices, the possibility of defects cannot be eliminated entirely. To minimize risks of damage or injury to persons or property arising from a defect in an NEC semiconductor device, customers must incorporate sufficient safety measures in its design, such as redundancy, fire-containment, and anti-failure features.

NEC devices are classified into the following three quality grades:

"Standard", "Special", and "Specific". The Specific quality grade applies only to devices developed based on a customer designated "quality assurance program" for a specific application. The recommended applications of a device depend on its quality grade, as indicated below. Customers must check the quality grade of each device before using it in a particular application.

Standard: Computers, office equipment, communications equipment, test and measurement equipment, audio and visual equipment, home electronic appliances, machine tools, personal electronic equipment and industrial robots

Special: Transportation equipment (automobiles, trains, ships, etc.), traffic control systems, anti-disaster systems, anti-crime systems, safety equipment and medical equipment (not specifically designed for life support)

Specific: Aircrafts, aerospace equipment, submersible repeaters, nuclear reactor control systems, life support systems or medical equipment for life support, etc.

The quality grade of NEC devices is "Standard" unless otherwise specified in NEC's Data Sheets or Data Books. If customers intend to use NEC devices for applications other than those specified for Standard quality grade, they should contact an NEC sales representative in advance.

Anti-radioactive design is not implemented in this product.