

AN8783SB

4-channel linear driver IC for CD/CD-ROM drive

■ Overview

The AN8783SB employs one channel of power op-amp. system and three channels of H-bridge system. Two channels out of three channels of H-bridge method are a current feedback system. So this IC is optimum for driving an actuator and a motor of CD/CD-ROM drive. It comes with a surface mount package which excels in a heat radiation characteristic.

■ Features

- Little phase delay due to current feedback system (2-channel for actuator)
- 4 modes of forward, reverse rotations, braking and standby can be selected from channels for loading motor (H-bridge method) by a digital signal from a microcomputer.
- Wide output dynamic range regardless of reference voltage of the system
- Setting the input level of a driver by an external resistor is possible.
- PC (power cut) function built-in (common for ch. 1, ch. 3 and ch. 4)
- Thermal shut-down circuit built-in (with hysteresis)

■ Applications

- CD/CD-ROM drive

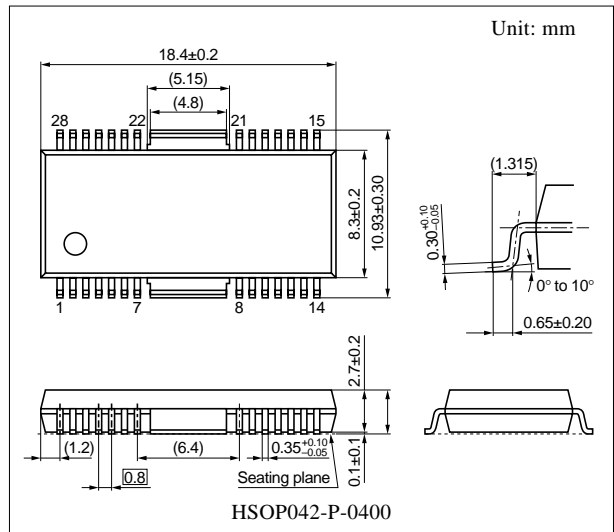

■ Block Diagram

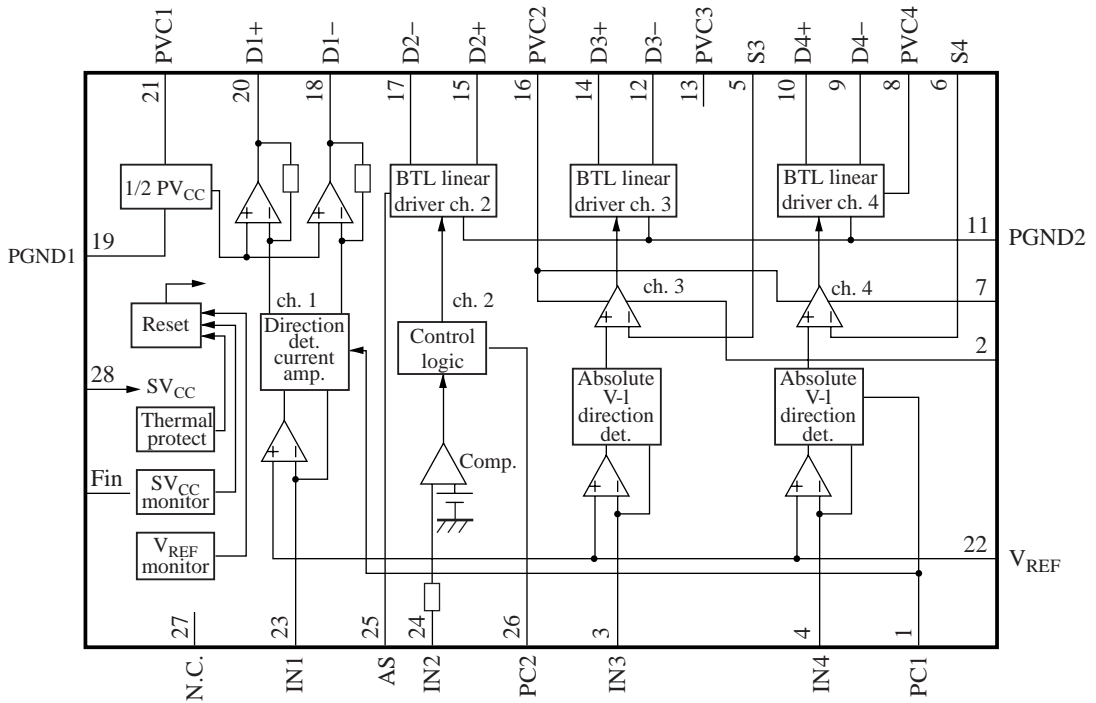

■ Pin Descriptions

Pin No.	Description	Pin No.	Description
1	PC1 (power cut) input pin	16	Driver-2 power supply pin
2	Driver-3 phase compensation pin	17	Driver-2 reverse rotation output pin
3	Driver-3 input pin	18	Driver-1 reverse rotation output pin
4	Driver-4 input pin	19	Driver-1 GND pin
5	Driver-3 feedback pin	20	Driver-1 forward rotation output pin
6	Driver-4 feedback pin	21	Driver-1 power supply pin
7	Driver-4 phase compensation pin	22	V _{REF} input pin
8	Driver-4 current feedback power supply pin	23	Driver-1 input pin
9	Driver-4 reverse rotation output pin	24	Driver-2 input pin
10	Driver-4 forward rotation output pin	25	Driver-2 output voltage adjustment pin
11	Driver-2, driver-4 GND pin	26	PC2 (power cut) input pin
12	Driver-3 reverse rotation output pin	27	N.C.
13	Driver-3 current feedback power supply pin	28	Power supply pin
14	Driver-3 forward rotation output pin	Fin	GND pin
15	Driver-2 forward rotation output pin		

■ Absolute Maximum Ratings

Parameter	Symbol	Rating	Unit
Supply voltage	SV_{CC}	14.4	V
Supply current	I_{CC}	—	mA
Power dissipation *2	P_D	542	mW
Operating ambient temperature *1	T_{opr}	-30 to +85	°C
Storage temperature *1	T_{stg}	-55 to +150	°C

Note) *1: Except for the operating ambient temperature and storage temperature, all ratings are for $T_a = 25^\circ\text{C}$.

*2: Referring to "■ Application Circuit Example", use within the range of $P_D = 542$ mW or less at $T_a = 85^\circ\text{C}$, following the allowable power dissipation characteristic curve of "■ Application Notes".

■ Recommended Operating Range

Parameter	Symbol	Range	Unit
Supply voltage	SV_{CC}	6.4 to 14	V
	PV_{C1}, PV_{C2}	4.5 to 14	

■ Electrical Characteristics at $SV_{CC} = 12\text{ V}$, $V_{CC1} = 12\text{ V}$, $V_{CC2} = 5\text{ V}$, $R_L = 8\ \Omega$, $V_{PC1} = 0\text{ V}$, $V_{PC2} = 5\text{ V}$, $T_a = 25^\circ\text{C}$

Parameter	Symbol	Conditions	Min	Typ	Max	Unit
Current consumption 1 with no signal	I_{SVCC}	$I_{IN1} = I_{IN3} = I_{IN4} = 0\ \mu\text{A}$	—	15	30	mA
Current consumption 2 with no signal	I_{VCC1}	$I_{IN1} = I_{IN3} = I_{IN4} = 0\ \mu\text{A}$	—	4	6	mA
Current consumption 3 with no signal	I_{VCC2}	$I_{IN1} = I_{IN3} = I_{IN4} = 0\ \mu\text{A}$	—	1	4	mA

Driver 1

Output offset voltage	V_{OOF-1}		-30	0	30	mV
Gain (+)	G_{1+}		18.5	21.0	23.5	dB
Relative gain (+/-)	ΔG_{1-}		-3.0	0	3.0	dB
Limit voltage (+)	V_{L1+}		6.5	8.0	—	V
Limit voltage (-)	V_{L1-}		—	-8.0	-6.5	V

Driver 2

Output voltage 1 (+)	V_{21+}	$V_{PC1} = 5\text{ V}$, $V_{PC2} = 0\text{ V}$, $V_{IN2} = 1\text{ V}$, $R_{AS} = 10\text{ k}\Omega$	2.4	2.7	3.0	V
Output voltage 1 (-)	V_{21-}	$V_{PC1} = 5\text{ V}$, $V_{PC2} = 0\text{ V}$, $V_{IN2} = 4\text{ V}$, $R_{AS} = 10\text{ k}\Omega$	-3.0	-2.7	-2.4	V
Output voltage 2 (+)	V_{22+}	$V_{PC1} = 5\text{ V}$, $V_{PC2} = 0\text{ V}$, $V_{IN2} = 1\text{ V}$, $R_{AS} = 0\text{ k}\Omega$	3.4	4.0	—	V
Output voltage 2 (-)	V_{22-}	$V_{PC1} = 5\text{ V}$, $V_{PC2} = 0\text{ V}$, $V_{IN2} = 4\text{ V}$, $R_{AS} = 0\text{ k}\Omega$	—	-4.0	-3.4	V

■ Electrical Characteristics at $S_{V_{CC}} = 12\text{ V}$, $V_{CC1} = 12\text{ V}$, $V_{CC2} = 5\text{ V}$, $R_L = 8\ \Omega$, $V_{PC1} = 0\text{ V}$, $V_{PC2} = 5\text{ V}$, $T_a = 25^\circ\text{C}$ (continued)

Parameter	Symbol	Conditions	Min	Typ	Max	Unit
Driver 2 (continued)						
Braking ability	V_{BRK}	$V_{PC1} = 5\text{ V}$, $V_{PC2} = 0\text{ V}$, $V_{IN2} = 2.6\text{ V}$, $I_O = 200\text{ mA}$	—	0.3	1.0	V
Input pin bias current	I_{IN2}	$V_{PC1} = 5\text{ V}$, $V_{PC2} = 0\text{ V}$, $V_{IN2} = 5\text{ V}$	—	40	100	μA
Driver-2 power transistor current at power cut	I_{DRV2}	$V_{PC2} = 5\text{ V}$, $V_{IN2} = 2.6\text{ V}$	—	—	1.0	μA
Driver 3						
Output offset voltage	V_{OOF3}	$R_{S3} = 0.5\ \Omega$	-60	—	60	mV
Gain (+)	G_{3+}	$R_{S3} = 0.5\ \Omega$	8.5	10.5	12.5	dB
Relative gain (+/-)	ΔG_3	$R_{S3} = 0.5\ \Omega$	-1.0	0	1.0	dB
Limit voltage (+)	V_{L3+}	$R_{S3} = 0.5\ \Omega$	3.3	3.9	—	V
Limit voltage (-)	V_{L3-}	$R_{S3} = 0.5\ \Omega$	—	-3.9	-3.3	V
Dead zone width	V_{DZ3}	$R_{S3} = 0.5\ \Omega$	-5	15	45	mV
Driver 3						
Output offset voltage	V_{OOF4}	$R_{S4} = 0.5\ \Omega$	-60	—	60	mV
Gain (+)	G_{4+}	$R_{S4} = 0.5\ \Omega$	8.5	10.5	12.5	dB
Relative gain (+/-)	ΔG_4	$R_{S4} = 0.5\ \Omega$	-1.0	0	1.0	dB
Limit voltage (+)	V_{L4+}	$R_{S4} = 0.5\ \Omega$	3.3	3.9	—	V
Limit voltage (-)	V_{L4-}	$R_{S4} = 0.5\ \Omega$	—	-3.9	-3.3	V
Dead zone width	V_{DZ4}	$R_{S4} = 0.5\ \Omega$	-5	15	45	mV
Power cut operation						
PC1 threshold high-level voltage	V_{PC1H}		3.5	—	—	V
PC1 threshold low-level voltage	V_{PC1L}		—	—	1.0	V
PC2 threshold high-level voltage	V_{PC2H}		3.5	—	—	V
PC2 threshold low-level voltage	V_{PC2L}		—	—	1.0	V
PC1 input current	I_{PC1}		—	70	120	μA
PC2 input current	I_{PC2}		—	70	120	μA
Reset circuit						
Reset operation release supply voltage	V_{RST}		—	—	5	V
V_{REF} detection voltage	V_R		1.35	—	—	V

■ Electrical Characteristics at $V_{CC} = 12\text{ V}$, $V_{CC1} = 12\text{ V}$, $V_{CC2} = 5\text{ V}$, $R_L = 8\ \Omega$, $V_{PC1} = 0\text{ V}$, $V_{PC2} = 5\text{ V}$, $T_a = 25^\circ\text{C}$ (continued)

• Design reference data

Note) The characteristics listed below are theoretical values based on the IC design and are not guaranteed.

Parameter	Symbol	Conditions	Min	Typ	Max	Unit
Thermal protection circuit						
Thermal protection operating temperature	T_{THD}		—	160	—	$^\circ\text{C}$
Thermal protection hysteresis width	ΔT_{THD}		—	45	—	$^\circ\text{C}$
Reset circuit						
Voltage detection reset hysteresis width	V_{HYS}		—	0.2	—	V

■ Usage Notes

- V_{CC} must be used in the highest potential. Otherwise it possibly causes an operation error.
- Ch. 3 and ch. 4 are current feedback type drivers. Do not apply voltage directly to PVC3 and PVC4, but apply from PVC2 through the current feedback detection resistors RS3 and RS4, respectively. And commonly connect S3 pin to PVC3 pin and S4 pin to PVC4 pin.

At this time, as an output current flows on the detection resistors RS3 and RS4, use a resistor which has a sufficient allowable power dissipation.

To set gain for ch. 3 and ch. 4, use the following formula:

$$\frac{|V_{IN3(4)} - V_{REF}|}{R_{3(4)} + 500\ \Omega} \times 2.2\ \text{k}\Omega = R_{S3(4)} \times I_{OUT3(4)}$$

(I_{OUT3} and I_{OUT4} are the load current for ch. 3 and ch. 4, respectively.)

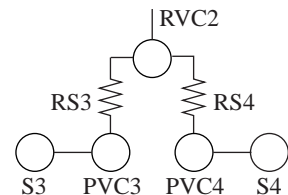

3. Power cut operation

Power cut pins PC1 (for ch. 1, ch. 3, ch. 4) and PC2 (only for ch. 2) are high for mute and low for active.

While ch. 2 is exclusive to a loading motor, ch. 2, ch. 3 and, ch. 4 are driven by the output current from the same source (PVC2). Therefore, do not use ch. 2 and ch. 3, ch. 4 simultaneously because noise is likely to be put on ch. 3, ch. 4 when ch. 2 is being driven.

4. Appropriate care should be taken on the characteristics.

When changing an external circuit constant on actual use, secure an appropriate margin in consideration of characteristic fluctuation of external parts and our ICs including transient characteristics as well as static ones.

- Avoid the short-circuits between output pin and V_{CC} , output pin and GND (line-to-supply and line-to-ground), and between output pins (load short-circuit). Otherwise, the IC is likely to emit smoke and break down.

Application Notes

- $P_D - T_a$ curves of HSOP042-P-0400

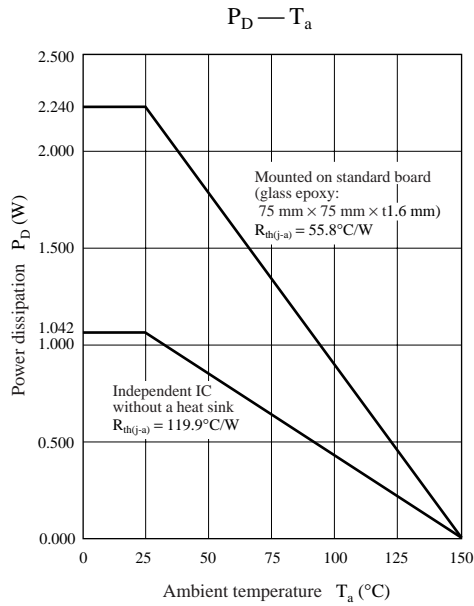

Application Circuit Example

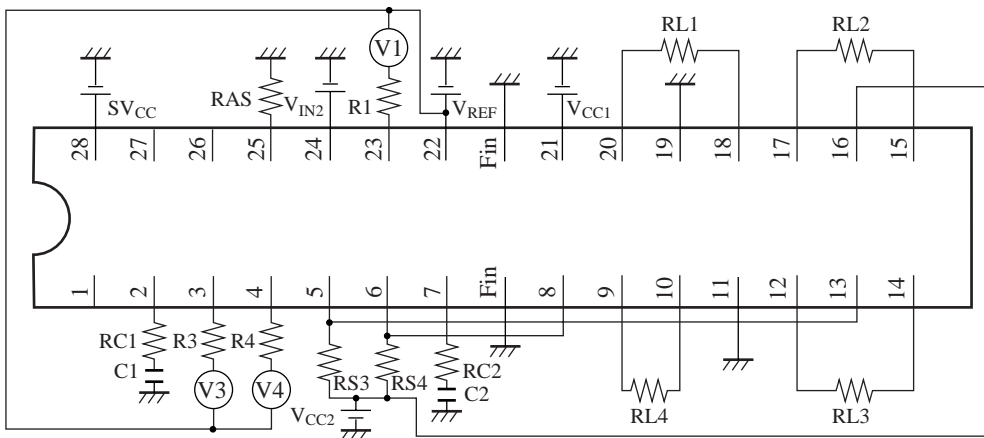

When the AN8783SB is used, take into account the following cautions and follow the power dissipation characteristic curve.

1. Load current I_{P1} flowing into load RL1 is supplied through pin 21.

$$I_{P1} = |V_{20} - V_{18}| / R_{L1}$$

2. Load current I_{P2} flowing into load RL2 is supplied through pin 16.

$$I_{P2} = |V_{17} - V_{15}| / R_{L2}$$

3. Load current I_{P3} flowing into load RL3 is supplied through pin 13 via the resistor RS3.

$$I_{P3} = |V_{14} - V_{12}| / R_{L3}$$

4. Load current I_{P4} flowing into load RL4 is supplied through pin 8 via the resistor RS4.

$$I_{P4} = |V_{10} - V_9| / R_{L4}$$

■ Application Circuit Example (continued)

5. Dissipation increase (ΔP_D) inside the IC (power output stage) caused by loads RL1, RL2, RL3 and RL4 is as follows:

$$\begin{aligned}\Delta P_D &= (V_{CC1} - |V_{20} - V_{18}|) \times \frac{|V_{20} - V_{18}|}{R_{L1}} + \{V_{CC2} - (R_{S3} + R_{L3}) \times \frac{|V_{14} - V_{12}|}{R_{L3}}\} \times \frac{|V_{14} - V_{12}|}{R_{L3}} \\ &= (V_{CC2} - |V_{17} - V_{15}|) \times \frac{|V_{17} - V_{15}|}{R_{L2}} + \{V_{CC2} - (R_{S4} + R_{L4}) \times \frac{|V_{10} - V_9|}{R_{L4}}\} \times \frac{|V_{10} - V_9|}{R_{L4}}\end{aligned}$$

6. Dissipation increase (ΔP_S) inside the IC (signal block supplied from pin 28) caused by loads RL1, RL2, RL3 and RL4 comes roughly as follows:

$$\begin{aligned}\Delta P_S &= 3 \times \frac{V_1}{R_1} \times (2 \times SV_{CC} + |V_{20} - V_{18}|) + \frac{I_{P2}}{K} \times (SV_{CC} - |V_{17} - V_{15}|) \\ &\quad + \frac{I_{P3}}{K} \times (SV_{CC} - |V_{14} - V_{12}|) + \frac{I_{P4}}{K} \times (SV_{CC} - |V_{10} - V_9|), \text{ where } K \approx 100\end{aligned}$$

7. Dissipation increase in a driver operating mode is $\Delta P_D + \Delta P_S$.

8. Allowable power dissipation without load (P_{D1}) can be found as follows:

$$P_{D1} = SV_{CC} \times I_{(SVCC)} + V_{CC1} \times I_{(VCC1)} + V_{CC2} \times I_{(VCC2)}$$

9. Allowable power dissipation in a load operating mode (P_D) comes roughly as follows:

$$P_D = P_{D1} + \Delta P_D + \Delta P_S$$