

FEATURES

- Normally Open, Single Pole Single Throw
- Control 400 VAC or DC Voltage
- Switch 130 mA Loads
- LED Control Current, 2mA
- Low ON-Resistance
- dv/dt , >500 V/ms
- Isolation Test Voltage, 1500 VAC_{RMS}
- UL, CSA, FCC compatible
- Applications
 - Telecommunications
 - Telecom Switching
 - Tip/Ring Circuits
 - Modem Switching (Laptop, Notebook, Pocket Size)
 - Hookswitch
 - Dial Pulsing
 - Ground Start
 - Ringer Injection
 - Instrumentation
 - Multiplexers
 - Data Acquisition
 - Electronic Switching
 - I/O Subsystems
 - Meters (Watt-Hour, Water, Gas)
 - Medical Equipment
 - High Voltage Test Equipment
 - TRIAC Driver
 - Motor Control
 - Security
 - Aerospace
 - Industrial Controls

DESCRIPTION

The AQY214S is a single pole single throw (SPST), normally open (NO), Mos Relay. The relay can control AC or DC loads currents up to 130 mA, with a supply voltage up to 400 V. The device is packaged in a 4 pin SO package. This package offers an insulation dielectric withstand of 1500 VAC_{RMS}.

The coupler consists of a AlGaAs LED that is optically coupled to a dielectrically isolated photodiode array which drives two series connected high voltage MOS transistors. The typical ON-Resistance is 20 Ω at 25 mA and is linear up to 50mA. The incremental resistance drops to less than 20 Ω beyond 50 mA while reducing internal power dissipation at high load currents.

- Turn on/Turn off time

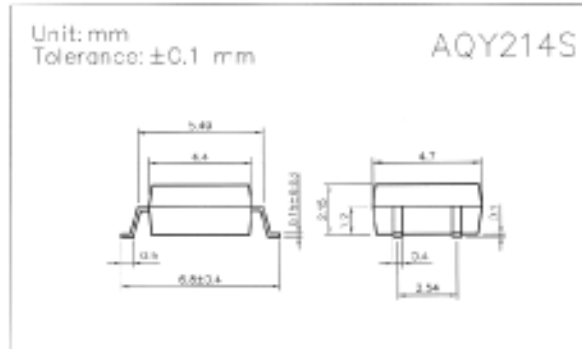

Absolute Maximum Ratings ($T_A = 25^\circ\text{C}$)

Emitter (Input)

Reverse Voltage.....	5.0V
Continuous Forward Current.....	50mA
Peak Forward Current (1s).....	1A
Power Dissipation.....	100mW
Derate Linearly from 25 $^\circ\text{C}$	3mW/ $^\circ\text{C}$

Detector (Output)

Output Breakdown Voltage.....	$\pm 400\text{V}$
Continuous Load Current.....	$\pm 130\text{mA}$
Power Dissipation.....	500mW

General Characteristics

Isolation Test Voltage.....	1500VAC _{RMS}
Isolation Resistance	
$V_{IO} = 500\text{V}, T_A = 25^\circ\text{C}$	$\geq 10^{10}\Omega$
Total Power Dissipation.....	550mW
Derate Linearly from 25 $^\circ\text{C}$	2.5mW/ $^\circ\text{C}$
Storage Temperature Range.....	-40 to +150 $^\circ\text{C}$
Operating Temperature Range.....	-40 to +85 $^\circ\text{C}$
Junction Temperature.....	100 $^\circ\text{C}$
Soldering Temperature, 2mm from case, 10 sec...	260 $^\circ\text{C}$

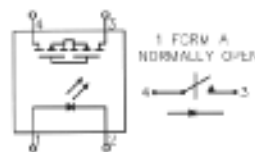

Characteristics

(T_A = 25°C)

Description	Symbol	Min.	Typ.	Max.	Unit	Test Condition
Emitter (Input)						
Forward Voltage	V _F		1.8	2.0	V	I _F = 10 mA
Operation Input Current	I _{FON}			5	mA	V _L = ± 20 V, I _L = 100 mA, t = 10 ms
Recovery Input Current	I _{FOFF}	0.2			mA	V _L = ± 20 V, I _L = < 5 μA
Detector (output)						
Output Breakdown Voltage	V _B	400			V	I _B = 50 μA
Output Off-State Leakage	I _{T(OFF)}		0.2	1	μA	V _T = 100 V, I _F = 0 mA
I/O Capacitance	C _{ISO}		6		pF	I _F = 0, f = 1 MHz
ON Resistance	R _{ON}		20	30	Ω	I _L = 100 mA, I _F = 10 mA
Turn-on Time	T _{ON}		0.3	1.0	ms	I _F = 10 mA, V _L = ± 20 V
Turn-off Time	T _{OFF}		0.7	1.5	ms	t = 10 ms, I _L = ± 100 mA

Mos Relay Schematic and Wiring Diagrams					
Type	Schematic	Output configuration	Load	Con-nection	Wiring diagram
AQY214S		1a	AC/DC	-	

DATA CURVE

Load current vs. ambient temperature
 Allowable ambient temperature:
 -40°C to + 85°C

On resistance vs. ambient temperature
 Across terminals 3 and 4 pin
 LED current: 5 mA
 Continuous load current: 130 mA(DC)

Turn on time vs. ambient temperature
 Load voltage 400 V(DC)
 LED current : 5 mA
 Continuous load current: 130 mA(DC)

