

GaAs MMIC

Data Sheet

CMY 213

- Ultralinear mixer with integrated IF-amplifier and LO-Buffer for CDMA receiver applications
- Typical overall performance at cellular frequencies for $P_{LO} = -5$ dBm (operation conditions: 3 V, 8 mA; $f_{RF} = 850$ MHz; $f_{LO} = 740$ MHz):
Gain 9.5 dB, Input IP3 10 dBm, Noise figure 8 dB
- RF-frequency range 0.5 - 2.5 GHz
- Operating voltage range: 2.6 to 5 V
- Small SCT-598-8-1 plastic package

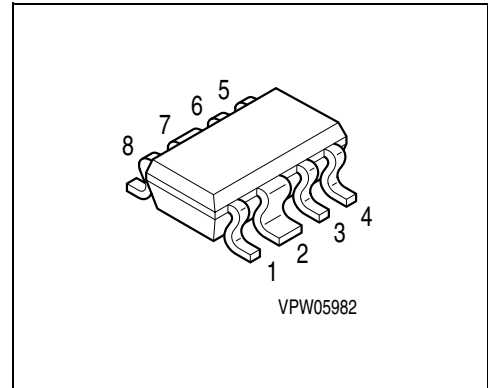

ESD: Electrostatic discharge sensitive device, observe handling precautions!

Type	Marking	Ordering Code (tape and reel)	Package
CMY 213	M6s	Q62702-M0032	SCT-598-8-1

Maximum Ratings

Parameter	Port	Symbol	Limit Values		Unit
			min.	max.	
Supply Voltage	3, 6	V_{DD}	0	5	V
DC-Voltage at LO Input	4	V_6	- 3	0.5	V
DC-Voltage at Mixer RF-IF Port	1	V_8	- 0.5	+ 0.5	V
Power into Mixer RF Port	1	P_{RF}	-	10	dBm
Power into LO Input	4	$P_{IN, LO}$	- 10	10	dBm
Channel Temperature	-	T_{Ch}	-	150	°C
Operating Temperature	-	T_{OP}	- 30	85	°C
Storage Temperature	-	T_{stg}	- 55	150	°C

Thermal Resistance

Parameter	Symbol	Values	Unit
Channel to Soldering Point (GND)	R_{thChS}	260	K/W

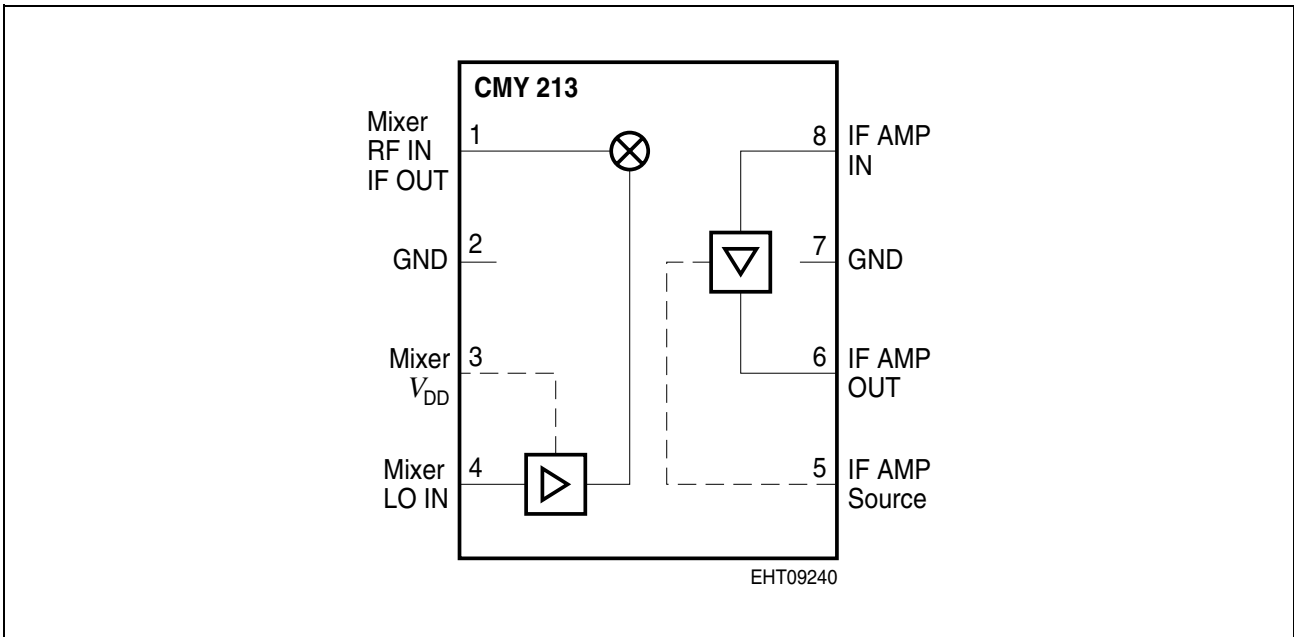

Figure 1 Block Diagram

Electrical Characteristics - Mixer

Parameter	Comment	Limit Values			Unit
		min.	typ.	max.	
RF - Frequency range	External match	0.5	–	2.5	GHz
LO - Frequency range	External match	0.5	–	2.5	GHz
IF Frequency range	External match	45	–	250	MHz

Typical Performance at Cellular Frequencies*

$T_A = 25\text{ °C}$; $V_{DD} = 3\text{ V}$, $f_{RF} = 850\text{ MHz}$; $f_{LO} = 740\text{ MHz}$; $P_{LO} = -5\text{ dBm}$;
 $f_{IF} = 110\text{ MHz}$; $Z_S = Z_L = 50\text{ }\Omega$; unless otherwise specified

Parameter	Symbol	Limit Values			Unit
		min.	typ.	max.	
Total operating Current (Mixer + IF amplifier)	I_{OP}	–	8.0	9.5	mA
Conversion Gain	G_C	8.0	9.5	–	dB
SSB Noise Figure	F_{SSB}	–	8	–	dB
RF Input -/ IF Output return loss (external matching required)	RFIrl/IFOrl	–	10	–	dB
3 rd Order Input Intercept Point	$IIP3$	8	10	–	dBm
LO-RF Isolation	Iso	–	10	–	dB

***Important Note:**

During production, the RF performance at PCS frequencies is screened. The passed devices also achieve the specified RF performance at cellular frequencies.

Test Conditions at PCS Frequencies

$T_A = 25\text{ °C}$; $V_{DD} = 3\text{ V}$, $f_{RF} = 1960\text{ MHz}$; $f_{LO} = 1750\text{ MHz}$; $P_{LO} = -5\text{ dBm}$;
 $f_{IF} = 210\text{ MHz}$; $Z_S = Z_L = 50\text{ }\Omega$; unless otherwise specified

Parameter	Symbol	Limit Values			Unit
		min.	typ.	max.	
Total operating Current (Mixer + IF amplifier)	I_{OP}	–	8.0	9.5	mA
Conversion Gain	G_C	7	8.5	–	dB
SSB Noise Figure	F_{SSB}	–	8.5	–	dB
RF Input -/ IF Output return loss (external matching required)	RFIrl/IFOrl	–	10	–	dB
3 rd Order Input Intercept Point	$IIP3$	10	12	–	dBm
LO-RF Isolation	Iso	–	6	–	dB

Typical Device Behavior at Cellular Frequencies

$T_A = 25\text{ }^\circ\text{C}$; $V_{DD} = 3\text{ V}$, $f_{RF} = 850\text{ MHz}$;
 $f_{LO} = 740\text{ MHz}$; $f_{IF} = 110\text{ MHz}$;
 $Z_S = Z_L = 50\ \Omega$; unless otherwise specified

Typical Device Behavior at PCS Frequencies

$T_A = 25\text{ }^\circ\text{C}$; $V_{DD} = 3\text{ V}$, $f_{RF} = 1960\text{ MHz}$;
 $f_{LO} = 1750\text{ MHz}$; $f_{IF} = 210\text{ MHz}$;
 $Z_S = Z_L = 50\ \Omega$; unless otherwise specified

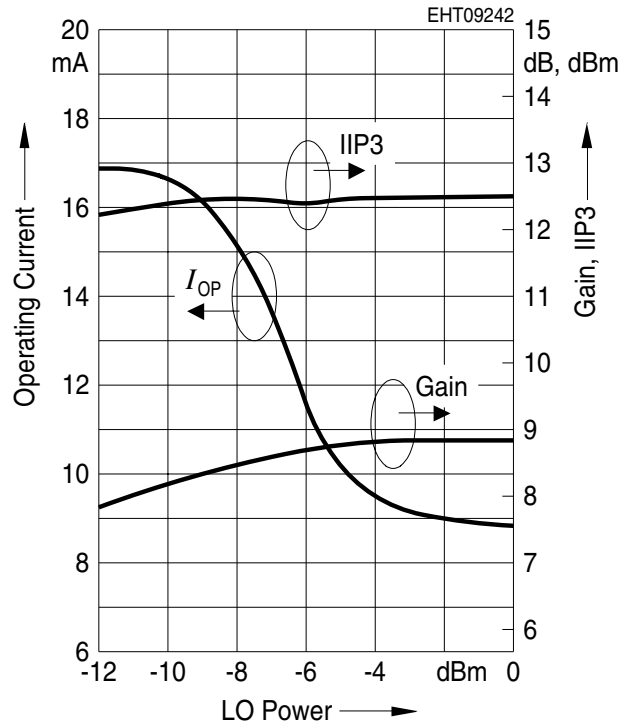
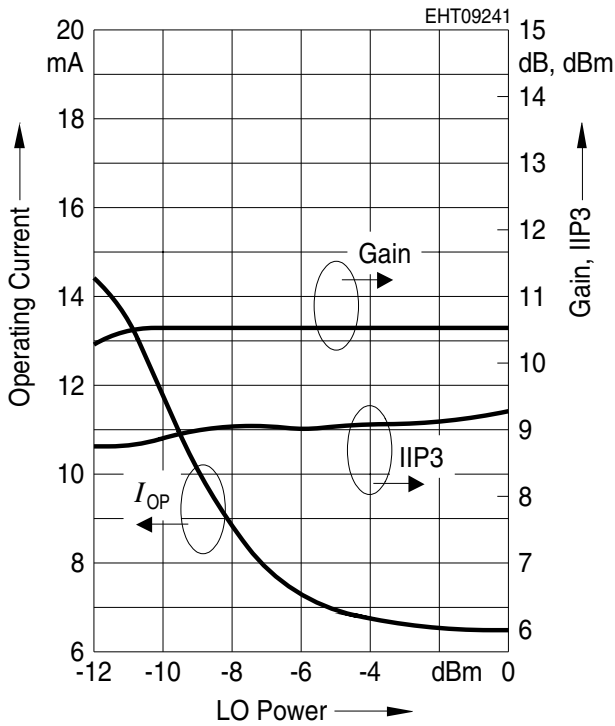

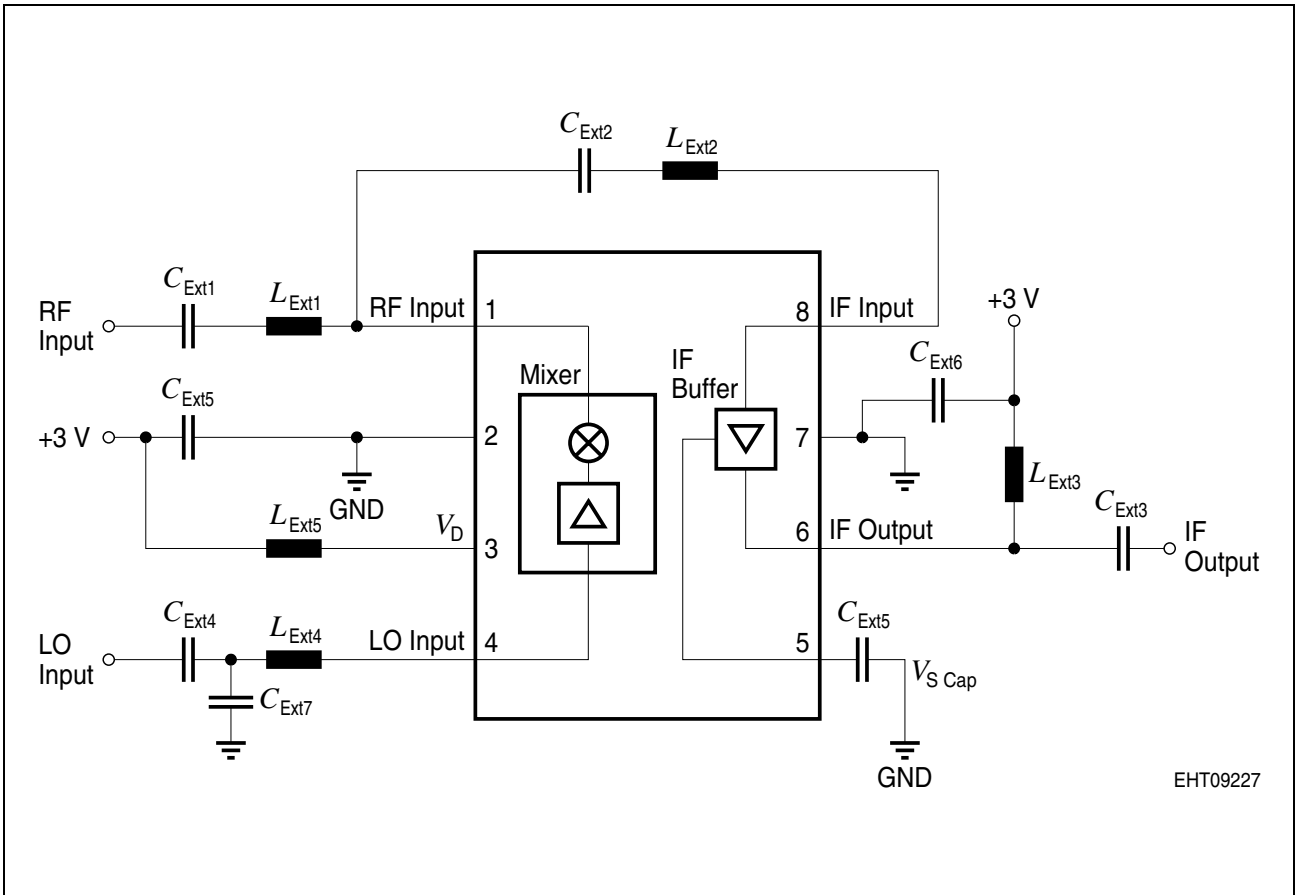

Figure 2 Test Circuit

External Components for Cellular Frequencies
 $f_{RF} = 850 \text{ MHz}; f_{LO} = 740 \text{ MHz}; f_{IF} = 110 \text{ MHz}$

Capacitors	(Murata 0402)	Inductors	(Toko)
C_{ext1}	1.5 pF	L_{ext1}	27 nH LL1005
C_{ext2}	1 nF	L_{ext2}	180 nH LL1608
C_{ext3}	18 pF	L_{ext3}	150 nH LL1608
C_{ext4}	100 pF	L_{ext4}	27 nH LL1005
C_{ext5}	1 nF	L_{ext5}	27 nH LL1005
C_{ext6}	1 nF	–	–
C_{ext7}	3 pF	–	–
C_{ext8}	100 nF	–	–

External Components for PCS Frequencies
 $f_{RF} = 1960 \text{ MHz}; f_{LO} = 1750 \text{ MHz}; f_{IF} = 210 \text{ MHz}$

Capacitors	(Murata 0402)	Inductors	(Toko)
C_{ext1}	1 pF	L_{ext1}	5.6 nH LL1005
C_{ext2}	1 nF	L_{ext2}	68 nH LL1608
C_{ext3}	8 pF	L_{ext3}	68 nH LL1608
C_{ext4}	22 pF	L_{ext4}	4.7 nH LL1005
C_{ext5}	1 nF	L_{ext5}	4.7 nH LL1005
C_{ext6}	1 nF	–	–
C_{ext7}	3 pF	–	–
C_{ext8}	100 nF	–	–

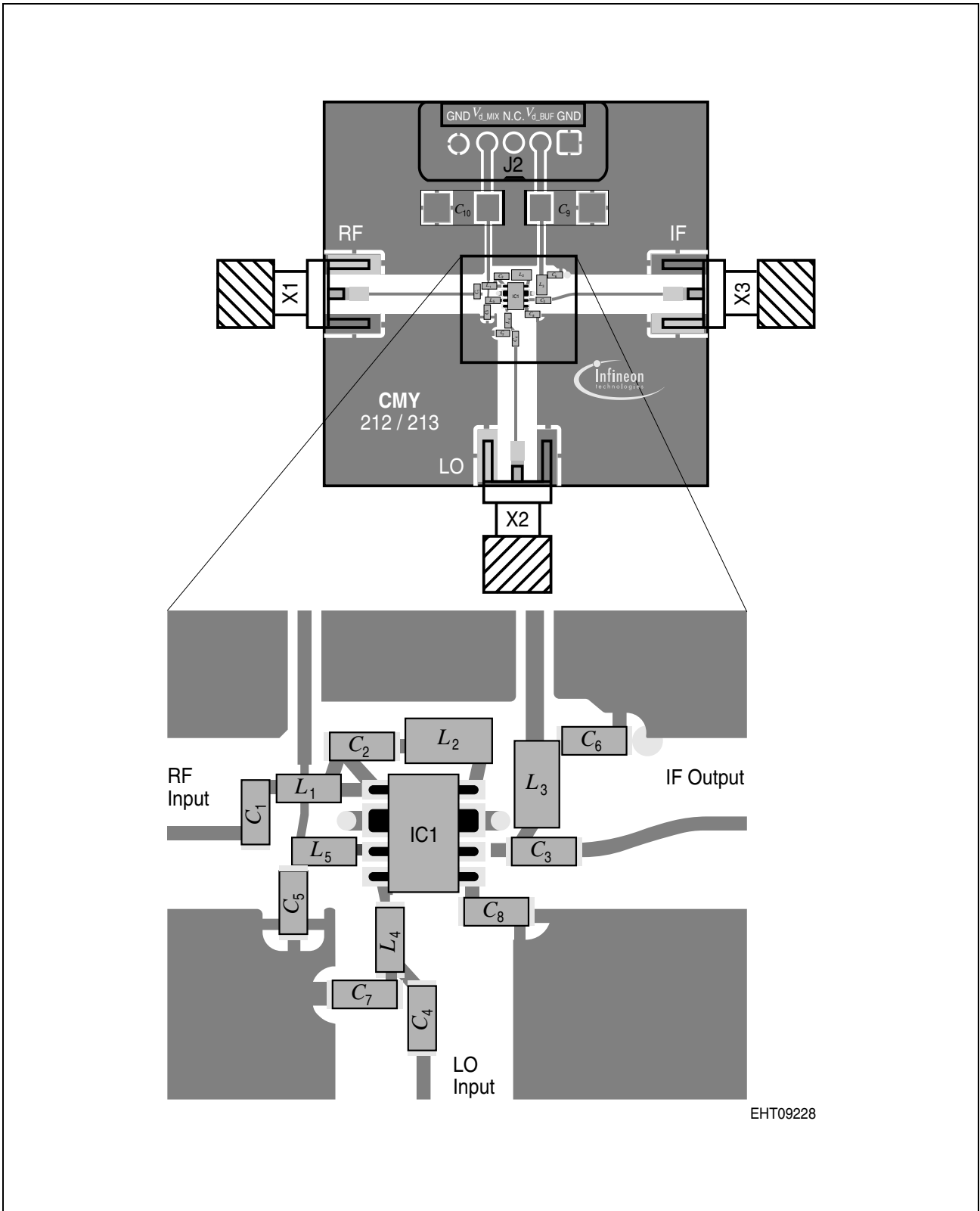

Figure 3 PCB Layout

Size 35 × 35 mm²

General Description and Notes for CMY 213

CMY 213 is a general purpose down-converter device designed for multiple applications such as cellular and PCS mobile phones, ISM bands, GPS receivers, L-band satellite terminals, WLAN and pagers. Due to its excellent intermodulation characteristics and its high conversion gain, CMY 213 is particularly suited for CDMA receiver applications.

The device combines an ultra-linear mixer with LO - driver and a single stage IF-amplifier in a very small SCT-598-8-1 package. The mixer section of CMY 213 combines low conversion losses and excellent intermodulation characteristics with low requirements of LO- and DC-power. The internal level controlled LO-Buffer enables a good performance over a wide LO level range. The input and output matching of the IF amplifier can be adapted externally within a frequency range from 45 to 250 MHz.

Package Outlines

SCT-598-8-1
(Special Package)

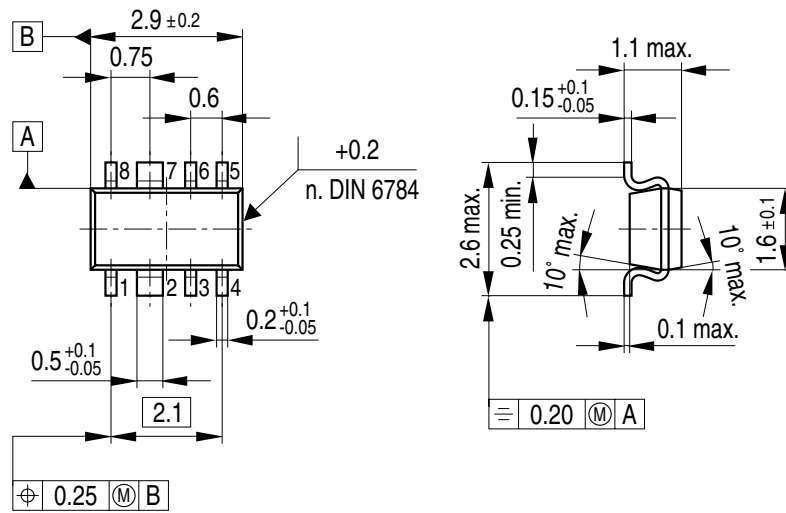

GPW05982

Sorts of Packing

Package outlines for tubes, trays etc. are contained in our Data Book "Package Information".

SMD = Surface Mounted Device

Dimensions in mm