

4M (256K x 16) Static RAM

Features

- Wide voltage range: 2.7V–3.6V
- Ultra-low active, standby power
- Easy memory expansion with \overline{CE} and \overline{OE} features
- TTL-compatible inputs and outputs
- Automatic power-down when deselected
- CMOS for optimum speed/power
- Package available in a standard 44-Pin TSOP Type II (forward pinout) package

Functional Description^[1]

The CY62146V is a high-performance CMOS static RAM organized as 256K words by 16 bits. These devices feature advanced circuit design to provide ultra-low active current. This is ideal for providing More Battery Life[®] (MoBL[®]) in portable applications such as cellular telephones. The device also has an automatic power-down feature that significantly reduces power consumption by 99% when addresses are not toggling. The device can also be put into standby mode when

deselected (\overline{CE} HIGH). The input/output pins (I/O_0 through I/O_{15}) are placed in a high-impedance state when: deselected (\overline{CE} HIGH), outputs are disabled (\overline{OE} HIGH), BHE and BLE are disabled (BHE , BLE HIGH), or during a write operation (\overline{CE} LOW, and \overline{WE} LOW).

Writing to the device is accomplished by taking Chip Enable (\overline{CE}) and Write Enable (\overline{WE}) inputs LOW. If Byte Low Enable (BLE) is LOW, then data from I/O pins (I/O_0 through I/O_7), is written into the location specified on the address pins (A_0 through A_{16}). If Byte High Enable (BHE) is LOW, then data from I/O pins (I/O_8 through I/O_{15}) is written into the location specified on the address pins (A_0 through A_{17}).

Reading from the device is accomplished by taking Chip Enable (\overline{CE}) and Output Enable (\overline{OE}) LOW while forcing the Write Enable (\overline{WE}) HIGH. If Byte Low Enable (BLE) is LOW, then data from the memory location specified by the address pins will appear on I/O_0 to I/O_7 . If Byte High Enable (BHE) is LOW, then data from memory will appear on I/O_8 to I/O_{15} . See the truth table at the back of this data sheet for a complete description of read and write modes.

Logic Block Diagram

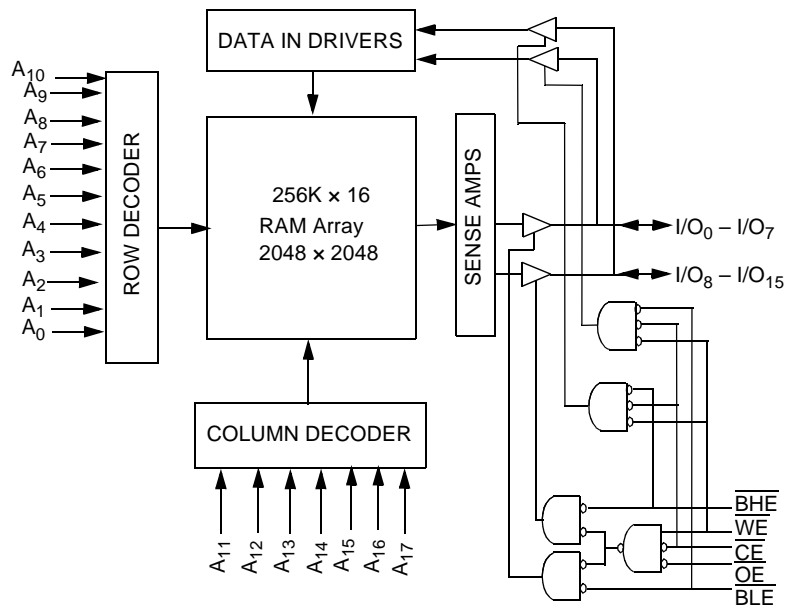

Note:

1. For best practice recommendations, please refer to the Cypress application note "System Design Guidelines" on <http://www.cypress.com>.

Pin Configurations

**TSOP II (Forward)
Top View**

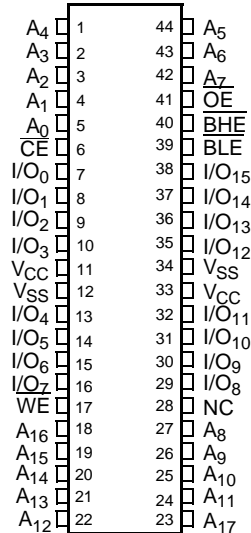

Maximum Ratings

(Above which the useful life may be impaired. For user guidelines, not tested.)

Storage Temperature	-65°C to +150°C
Ambient Temperature with Power Applied.....	-55°C to +125°C
Supply Voltage to Ground Potential	-0.5V to +4.6V
DC Voltage Applied to Outputs in High-Z State ^[2]	-0.5V to V _{CC} + 0.5V
DC Input Voltage ^[2]	-0.5V to V _{CC} + 0.5V

Output Current into Outputs (LOW).....	20 mA
Static Discharge Voltage.....	>2001V (per MIL-STD-883, Method 3015)
Latch-up Current.....	>200 mA

Operating Range

Range	Ambient Temperature	V _{CC}
Industrial	-40°C to +85°C	2.7V to 3.6V

Product Portfolio

Product	V _{CC} Range (V)			Speed (ns)	Power Dissipation			
	V _{CC(min.)}	V _{CC(typ.)} ^[3]	V _{CC(max.)}		Operating I _{CC} , (mA)		Standby I _{SB2} , (µA)	
					Typ. ^[3]	Maximum	Typ. ^[3]	Maximum
CY62146VLL	2.7	3.0	3.6	70	7	15	2	20

Notes:

- V_{IL(min.)} = -2.0V for pulse durations less than 20 ns.
- Typical values are included for reference only and are not guaranteed or tested. Typical values are measured at V_{CC} = V_{CC(typ.)}, T_A = 25°C.

Electrical Characteristics Over the Operating Range

Parameter	Description	Test Conditions	CY62146V-70			Unit
			Min.	Typ. ^[3]	Max.	
V _{OH}	Output HIGH Voltage	I _{OH} = -1.0 mA, V _{CC} = 2.7V	2.4			V
V _{OL}	Output LOW Voltage	I _{OL} = 2.1 mA, V _{CC} = 2.7V			0.4	V
V _{IH}	Input HIGH Voltage	V _{CC} = 3.6V	2.2		V _{CC} + 0.5V	V
V _{IL}	Input LOW Voltage	V _{CC} = 2.7V	-0.5		0.8	V
I _{IX}	Input Load Current	GND ≤ V _I ≤ V _{CC}	-1	±1	+1	μA
I _{OZ}	Output Leakage Current	GND ≤ V _O ≤ V _{CC} , Output Disabled	-1	+1	+1	μA
I _{CC}	V _{CC} Operating Supply Current	I _{OUT} = 0 mA, f = f _{MAX} = 1/t _{RC} , CMOS Levels		7	15	mA
		I _{OUT} = 0 mA, f = 1 MHz, CMOS Levels		1	2	mA
I _{SB1}	Automatic CE Power-down Current—CMOS Inputs	$\overline{CE} \geq V_{CC} - 0.3V$, V _{IN} ≥ V _{CC} - 0.3V or V _{IN} ≤ 0.3V, f = f _{MAX}		2	20	μA
I _{SB2}	Automatic CE Power-down Current—CMOS Inputs	$\overline{CE} \geq V_{CC} - 0.3V$, V _{IN} ≥ V _{CC} - 0.3V or V _{IN} ≤ 0.3V, f = 0	V _{CC} = 3.6V			

Capacitance^[4]

Parameter	Description	Test Conditions	Max.	Unit
C _{IN}	Input Capacitance	T _A = 25°C, f = 1 MHz, V _{CC} = V _{CC} (typ.)	6	pF
C _{OUT}	Output Capacitance		8	pF

Thermal Resistance

Parameter	Description	Test Conditions	BGA	TSOPII	Unit
Θ _{JA}	Thermal Resistance (Junction to Ambient) ^[4]	Still Air, soldered on a 4.25 x 1.125 inch, 4-layer printed circuit board	55	60	°C/W
Θ _{JC}	Thermal Resistance (Junction to Case) ^[4]		16	22	°C/W

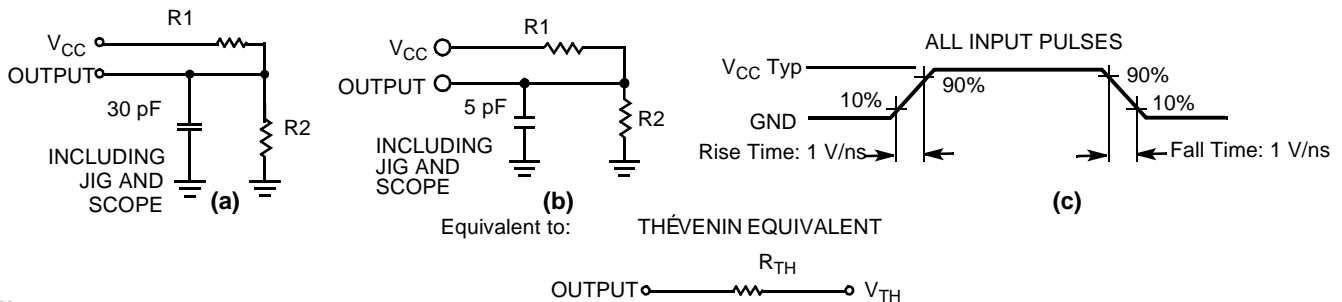
AC Test Loads and Waveforms

Note:

4. Tested initially and after any design or process changes that may affect these parameters.

Parameter	3.0V	Unit
R1	1105	Ohms
R2	1550	Ohms
R _{TH}	645	Ohms
V _{TH}	1.75	V

Data Retention Characteristics (Over the Operating Range)

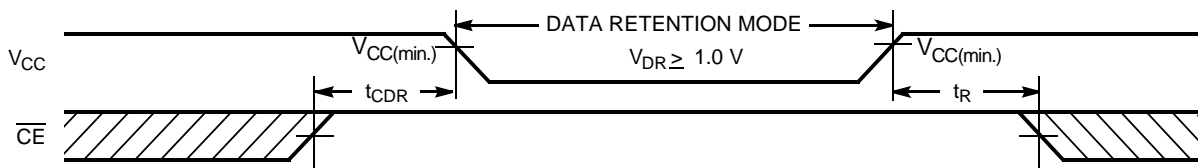
Parameter	Description	Conditions	Min.	Typ. ^[3]	Max.	Unit
V _{DR}	V _{CC} for Data Retention)		1.0		3.6	V
I _{CCDR}	Data Retention Current	V _{CC} = 1.0V, CE ≥ V _{CC} - 0.3V, V _{IN} ≥ V _{CC} - 0.3V or V _{IN} ≤ 0.3V; No input may exceed V _{CC} + 0.3V		1	10	μA
t _{CDR} ^[4]	Chip Deselect to Data Retention Time		0			ns
t _R ^[5]	Operation Recovery Time		70			ns

Data Retention Waveform

Switching Characteristics Over the Operating Range ^[6]

Parameter	Description	70 ns		Unit
		Min.	Max.	
Read Cycle				
t _{RC}	Read Cycle Time	70		ns
t _{AA}	Address to Data Valid		70	ns
t _{OHA}	Data Hold from Address Change	10		ns
t _{ACE}	CE LOW to Data Valid		70	ns
t _{DOE}	OE LOW to Data Valid		25	ns
t _{LZOE}	OE LOW to Low-Z ^[7, 8]	5		ns
t _{HZOE}	OE HIGH to High-Z ^[8]		20	ns
t _{LZCE}	CE LOW to Low-Z ^[7]	10		ns
t _{HZCE}	CE HIGH to High-Z ^[7, 8]		20	ns
t _{PU}	CE LOW to Power-up	0		ns
t _{PD}	CE HIGH to Power-down		70	ns
t _{DBE}	BHE / BLE LOW to Data Valid		35	ns
t _{LZBE}	BHE / BLE LOW to Low-Z	5		ns
t _{HZBE}	BHE / BLE HIGH to High-Z		20	ns
Write Cycle^[9, 10]				
t _{WC}	Write Cycle Time	70		ns

Notes:

- Full Device AC operation requires linear V_{CC} ramp from V_{DR} to V_{CC(min.)} ≥ 10 μs or stable V_{CC(min.)} ≥ 10 μs.
- Test conditions assume signal transition time of 5 ns or less, timing reference levels of 1.5V, input pulse levels of 0 to V_{CC(typ.)}, and output loading of the specified I_{OL}/I_{OH} and 30 pF load capacitance.
- At any given temperature and voltage condition, t_{HZCE} is less than t_{LZCE}, t_{HZOE} is less than t_{LZOE}, and t_{HZWE} is less than t_{LZWE} for any given device.
- t_{HZOE}, t_{HZCE}, and t_{HZWE} are specified with C_L = 5 pF as in part (b) of AC Test Loads. Transition is measured ±500 mV from steady-state voltage.
- The internal write time of the memory is defined by the overlap of CE LOW and WE LOW. Both signals must be LOW to initiate a write and either signal can terminate a write by going HIGH. The data input set-up and hold timing should be referenced to the rising edge of the signal that terminates the write.
- The minimum write cycle time for Write Cycle #3 (WE controlled, OE LOW) is the sum of t_{HZWE} and t_{SD}.

Switching Characteristics Over the Operating Range (continued)^[6]

Parameter	Description	70 ns		Unit
		Min.	Max.	
t_{SCE}	CE LOW to Write End	60		ns
t_{AW}	Address Set-up to Write End	60		ns
t_{HA}	Address Hold from Write End	0		ns
t_{SA}	Address Set-up to Write Start	0		ns
t_{PWE}	WE Pulse Width	40		ns
t_{BW}	BHE / BLE Pulse Width	60		ns
t_{SD}	Data Set-up to Write End	30		ns
t_{HD}	Data Hold from Write End	0		ns
t_{HZWE}	WE LOW to High-Z ^[7, 8]		25	ns
t_{LZWE}	WE HIGH to Low-Z ^[7]	10		ns

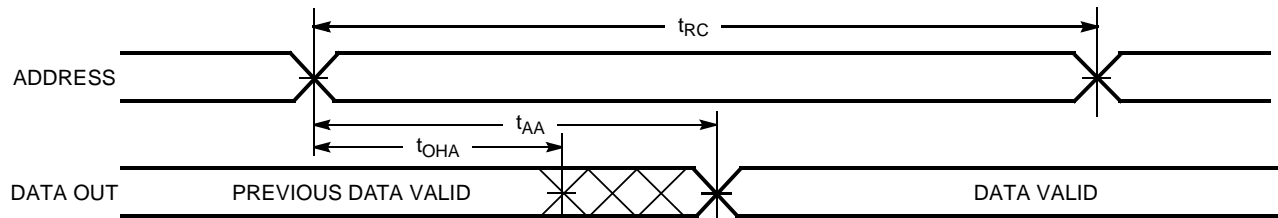
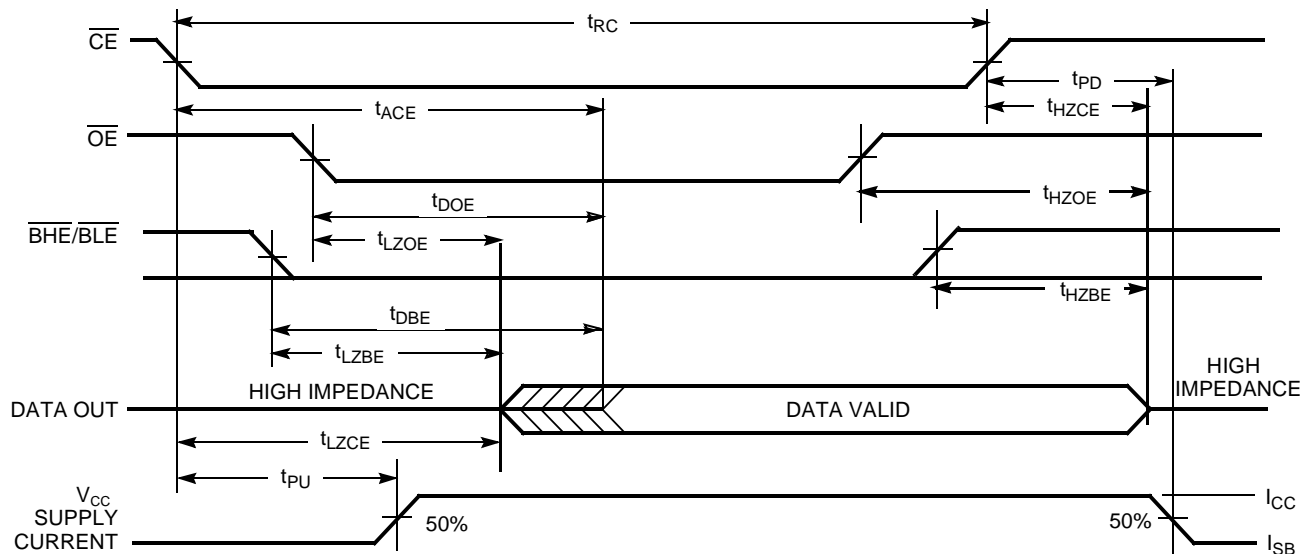
Switching Waveforms
Read Cycle No. 1 ^[11, 12]

Read Cycle No. 2 ^[12, 13]

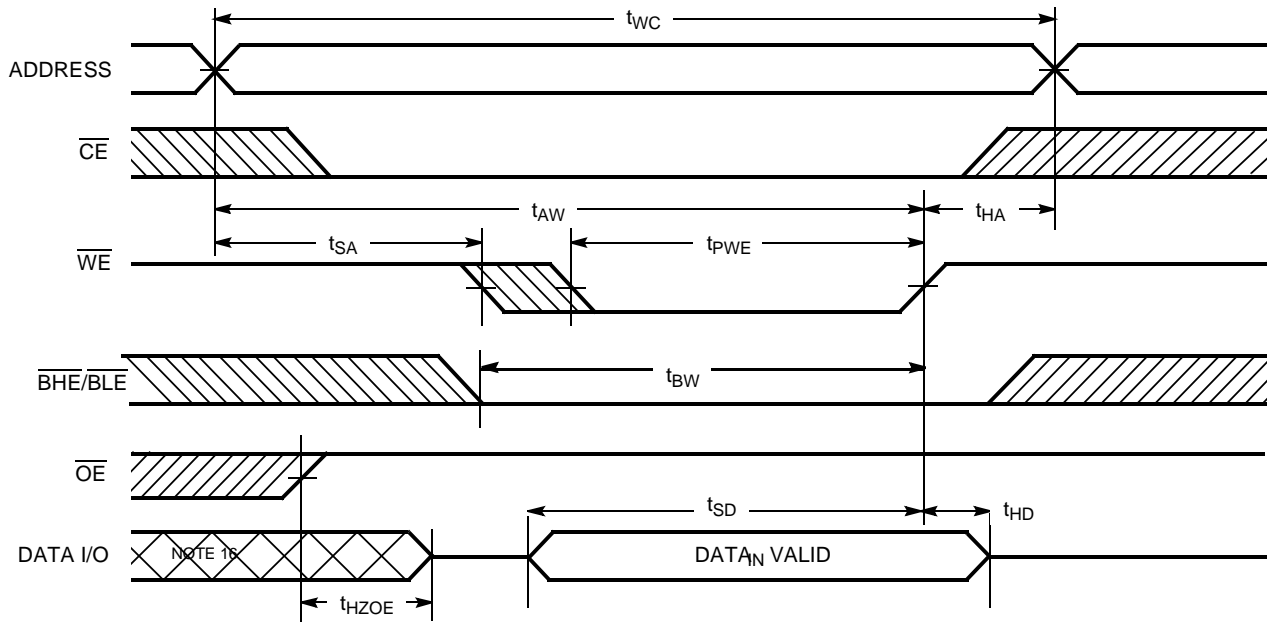
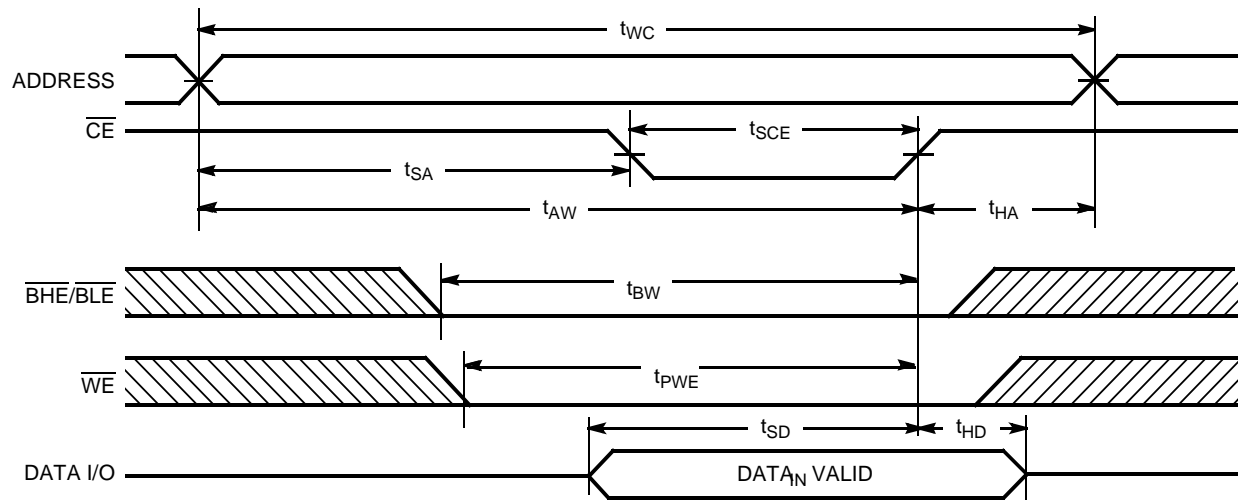
Notes:

- Device is continuously selected. \overline{OE} , $\overline{CE} = V_{IL}$.
- WE is HIGH for read cycle.
- Address valid prior to or coincident with \overline{CE} transition LOW.

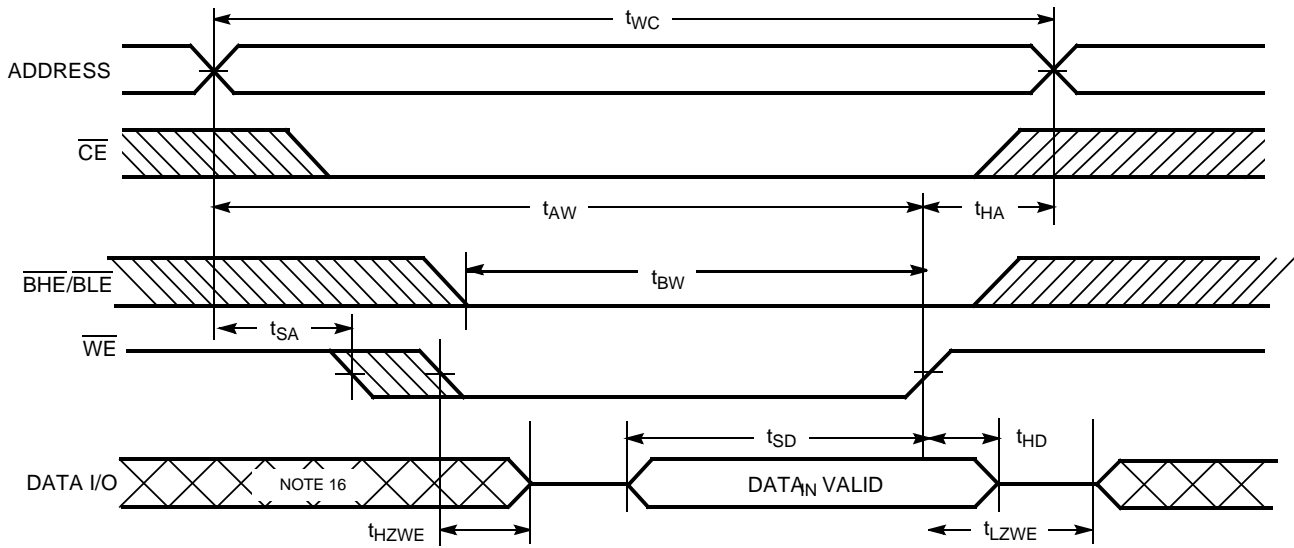
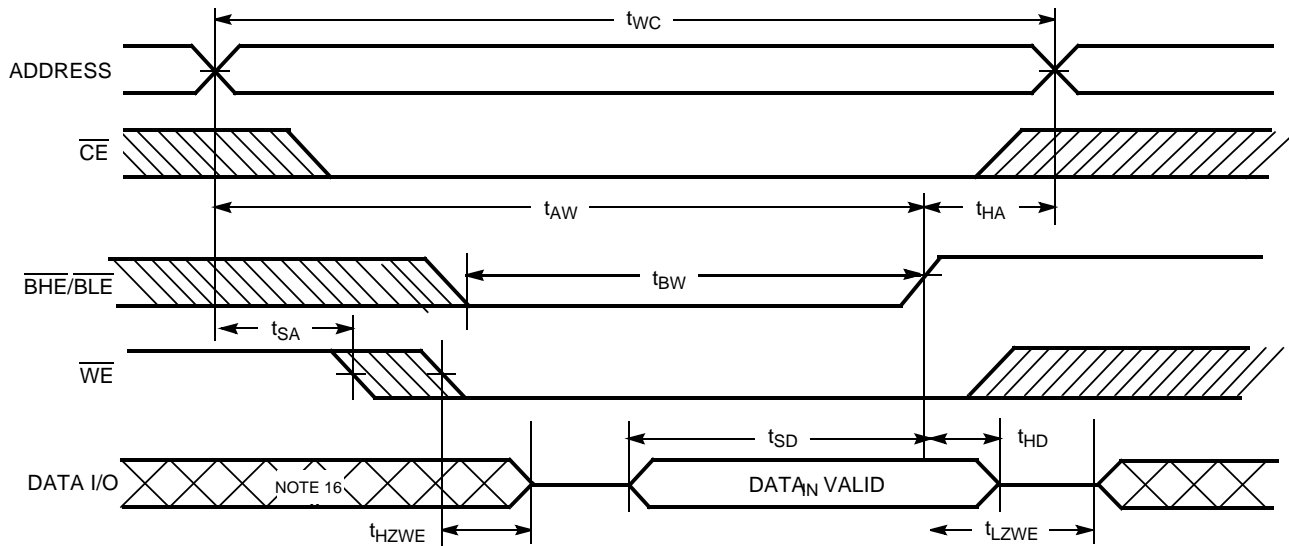
Switching Waveforms (continued)
Write Cycle No. 1 (\overline{WE} Controlled) ^[9, 14, 15]

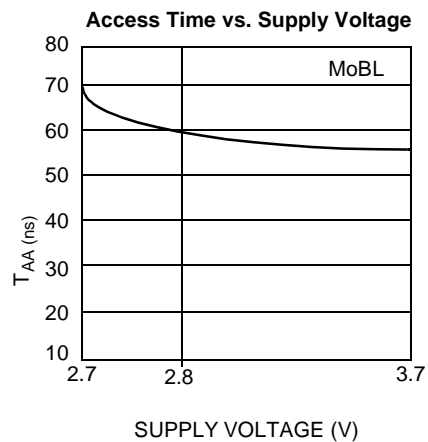
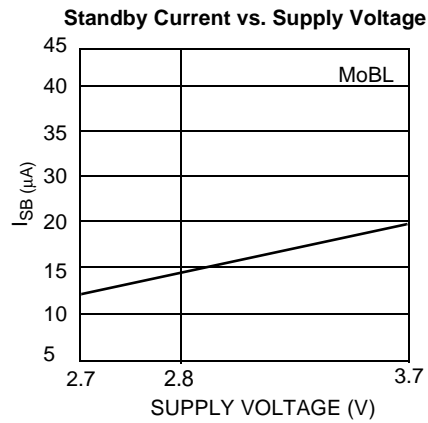
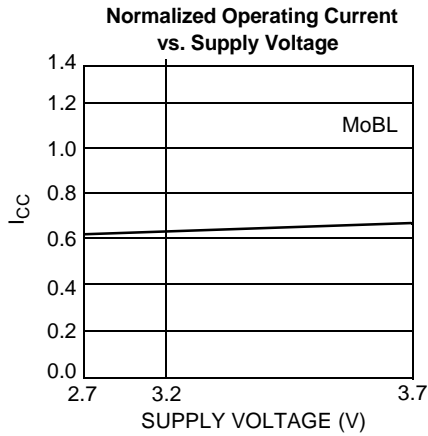
Write Cycle No. 2 (\overline{CE} Controlled) ^[9, 14, 15]

Notes:

14. Data I/O is high-impedance if $\overline{OE} = V_{IH}$.
15. If \overline{CE} goes HIGH simultaneously with \overline{WE} HIGH, the output remains in a high-impedance state.
16. During this period, the I/Os are in output state and input signals should not be applied.

Switching Waveforms (continued)
Write Cycle No. 3 ($\overline{\text{WE}}$ Controlled, $\overline{\text{OE}}$ LOW)^[10, 15]

Write Cycle No. 4 ($\overline{\text{BHE}}/\overline{\text{BLE}}$ Controlled, $\overline{\text{OE}}$ LOW)^[16]

Typical DC and AC Characteristics

Truth Table

\overline{CE}	\overline{WE}	\overline{OE}	\overline{BHE}	\overline{BLE}	Inputs/Outputs	Mode	Power
H	X	X	X	X	High-Z	Deselect/Power-down	Standby (I_{SB})
L	H	L	L	L	Data Out (I/O ₀ –I/O ₁₅)	Read	Active (I_{CC})
L	H	L	H	L	Data Out (I/O ₀ –I/O ₇); I/O ₈ –I/O ₁₅ in High-Z	Read	Active (I_{CC})
L	H	L	L	H	Data Out (I/O ₈ –I/O ₁₅); I/O ₀ –I/O ₇ in High-Z	Read	Active (I_{CC})
L	H	L	H	H	High-Z	Output Disabled	Active (I_{CC})
L	H	H	X	X	High-Z	Output Disabled	Active (I_{CC})
L	L	X	L	L	Data In (I/O ₀ –I/O ₁₅)	Write	Active (I_{CC})
L	L	X	H	L	Data In (I/O ₀ –I/O ₇); I/O ₈ –I/O ₁₅ in High-Z	Write	Active (I_{CC})
L	L	X	L	H	Data In (I/O ₈ –I/O ₁₅); I/O ₀ –I/O ₇ in High-Z	Write	Active (I_{CC})
L	L	X	H	H	High-Z	Output Disabled	Active (I_{CC})

Ordering Information

Speed (ns)	Ordering Code	Package Name	Package Type	Operating Range
70	CY62146VLL-70ZI	Z44	44-pin TSOP II	Industrial

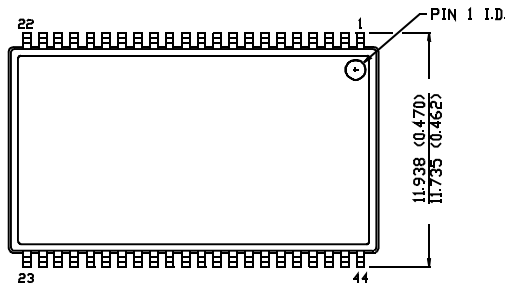
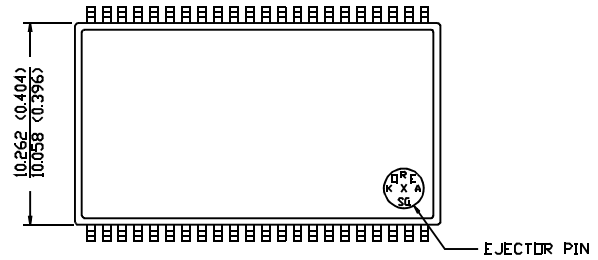
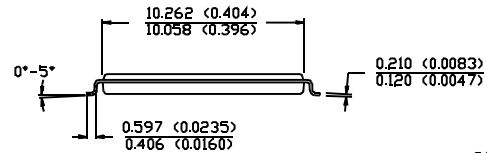
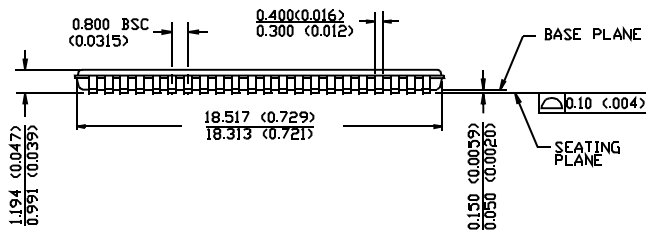
Package Diagram
44-Pin TSOP II Z44

 DIMENSION IN MM (INCH)
 MAX
 MIN

TOP VIEW

BOTTOM VIEW

51-85087-A

MoBL is a registered trademark, and More Battery Life is a trademark, of Cypress Semiconductor. All product and company names mentioned in this document are the trademarks of their respective holders.

Document Title: CY62146V MoBL[®] 4M (256K x 16) Static RAM
Document Number: 38-05159

REV.	ECN NO.	Issue Date	Orig. of Change	Description of Change
**	109963	10/02/01	SZV	Change from Spec number: 38-00647 to 38-05159
*A	116594	09/04/02	GBI	Added footnote 1. Deleted fBGA package; replacement fBGA package is available in CY62146CV30.