



133-MHz Spread Spectrum FTG for Pentium® II Platforms

Features

- Maximized EMI Suppression using Cypress's Spread Spectrum Technology
- Three copies of CPU outputs at 100 or 133 MHz
- Three copies of 66-MHz output at 3.3V
- Ten copies of PCI clocks at 33 MHz, 3.3V
- Two copies of 14.318-MHz reference output at 3.3V
- One copy of 48-MHz USB clock
- One copy of CPU-divide-by-2 output as reference input to Direct Rambus™ Clock Generator (Cypress W134)
- Available in 48-pin SSOP (300 mils)

Key Specifications

Supply Voltages: $V_{DDQ2} = 2.5V \pm 5\%$
 $V_{DDQ3} = 3.3V \pm 5\%$

CPU, CPUdiv2 Output Jitter: 250 ps
 CPU, CPUdiv2 Output Skew: 175 ps
 IOAPIC, 3V66 Output Skew: 250 ps
 PCI0:9 Output Skew: 500 ps
 Duty Cycle: 45/55

Spread Spectrum Modulation: -0.5%
 CPU to 3V66 Output Offset: 0.0–1.5 ns (CPU leads)
 3V66 to PCI Output Offset: 1.5–3.0 ns (3V66 leads)
 CPU to IOAPIC Output Offset: 1.5–4.0 ns (CPU leads)

Table 1. Pin Selectable Frequency

| SEL133/100# | SEL1 | SEL0 | Function |
|-------------|------|------|-------------------------------------|
| 0 | 0 | 0 | All outputs Three-State |
| 0 | 0 | 1 | (Reserved) |
| 0 | 1 | 0 | Active 100-MHz, 48-MHz PLL inactive |
| 0 | 1 | 1 | Active 100-MHz, 48-MHz PLL active |
| 1 | 0 | 0 | Test Mode |
| 1 | 0 | 1 | (Reserved) |
| 1 | 1 | 0 | Active 133-MHz, 48-MHz PLL inactive |
| 1 | 1 | 1 | Active 133-MHz, 48-MHz PLL active |

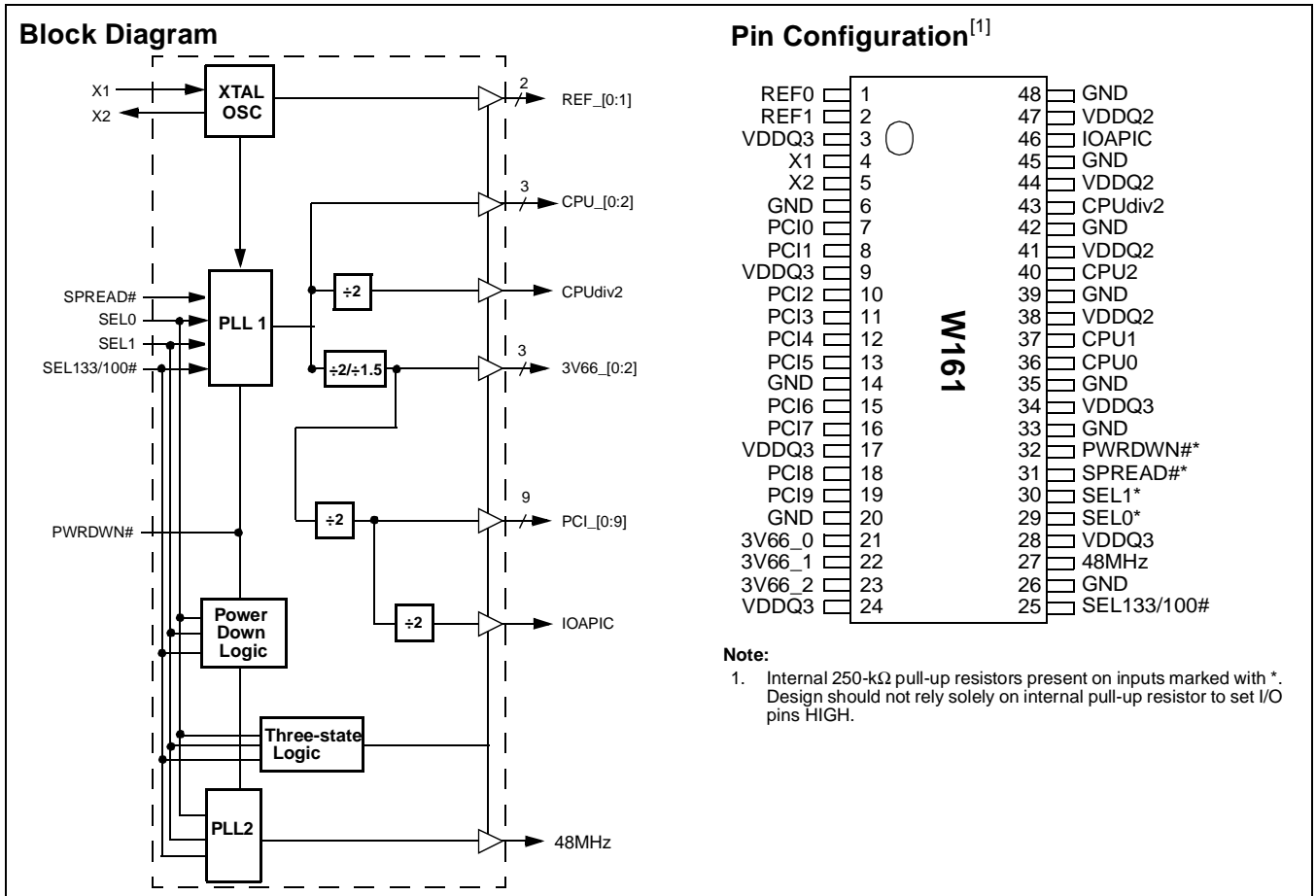

Note:
 1. Internal 250-kΩ pull-up resistors present on inputs marked with *. Design should not rely solely on internal pull-up resistor to set I/O pins HIGH.

Pentium is a registered trademark of Intel Corporation. Direct Rambus is a trademark of Rambus, Inc.

Pin Definitions

| Pin Name | Pin No. | Pin Type | Pin Description |
|-------------|---------------------------------------|----------|--|
| CPU0:2 | 36, 37, 40 | O | CPU Clock Outputs 0 through 2: CPU clock outputs. Their output voltage swing is controlled by voltage applied to VDDQ2. |
| PCI0:9 | 7, 8, 10, 11, 12, 13, 15, 16, 18, 19 | O | PCI Clock Outputs 0 through 9: Output voltage swing is controlled by voltage applied to VDDQ3. |
| CPUdiv2 | 43 | O | CPU-Divide-By-2 Output: This serves as a reference input signal for Direct Rambus Clock Generator (Cypress W134). The output voltage is determined by VDDQ2. |
| 3V66_0:2 | 21, 22, 23 | O | 66-MHz Clock Outputs 0 through 2: Output voltage swing is controlled by voltage applied to VDDQ3. |
| IOAPIC | 46 | O | I/O APIC Clock Output: Provides an output synchronous to CPU clock. See <i>Table 1</i> for their relation to other system clock outputs. |
| 48 MHz | 27 | O | 48-MHz Output: Fixed clock output at 48 MHz. |
| SPREAD# | 31 | I | Spread Spectrum Enable: This input enables spread spectrum modulation on the PLL1 generated frequency outputs of the W161. Modulation range is -0.5%. |
| PWRDWN# | 32 | I | Power Down Control |
| REF0:1 | 1, 2 | I | Fixed 14.318-MHz Output 0 and 1: Output voltage swing is controlled by voltage applied to VDDQ3. |
| SEL0:1 | 29, 30 | I | Mode Select Input 0 through 1: 3.3V LVTTTL-compatible input for selecting clock output modes. As shown in <i>Table 1</i> . |
| SEL133/100# | 25 | I | Frequency Selection Input: 3.3V LVTTTL-compatible input that selects CPU output frequency as shown in <i>Table 1</i> . |
| X1 | 4 | I | Crystal Connection or External Reference Frequency Input: This pin has dual functions. It can be used as an external 14.318-MHz crystal connection or as an external reference frequency input. |
| X2 | 5 | I | Crystal Connection: An input connection for an external 14.318-MHz crystal. If using an external reference, this pin must be left unconnected. |
| VDDQ2 | 38, 41, 44, 47 | P | Power Connection: Connected to 2.5V power supply. |
| VDDQ3 | 3, 9, 17, 24, 28, 34 | P | Power Connection: Connected to 3.3V power supply. |
| GND | 6, 14, 20, 26, 33, 35, 39, 42, 45, 48 | G | Ground Connection: Connect all ground pins to the common system ground plane. |

Overview

The W161, a motherboard clock synthesizer, provides 2.5V CPU clock outputs for advanced CPU and a CPU-divide-by-2 reference frequency for Direct Rambus Clock Generator (such Cypress W134) interface. Fixed output frequencies are provided for other system functions.

CPU Frequency Selection

CPU frequency is selected with input pins 25, 29, and 30 (SEL133/100#, SEL0, and SEL1, respectively). Refer to *Table 1* for details.

Output Buffer Configuration

Clock Outputs

All clock outputs are designed to drive serial terminated clock lines. The W161 outputs are CMOS-type, which provide rail-to-rail output swing.

Crystal Oscillator

The W161 requires one input reference clock to synthesize all output frequencies. The reference clock can be either an externally generated clock signal or the clock generated by the internal crystal oscillator. When using an external clock signal, pin X1 is used as the clock input and pin X2 is left open.

The internal crystal oscillator is used in conjunction with a quartz crystal connected to device pins X1 and X2. This forms a parallel resonant crystal oscillator circuit. The W161 incorporates the necessary feedback resistor and crystal load capacitors. Including typical stray circuit capacitance, the total load presented to the crystal is approximately 18 pF. For optimum frequency accuracy without the addition of external capacitors, a parallel-resonant mode crystal specifying a load of 18 pF should be used. This will typically yield reference frequency accuracies within ± 100 ppm.

Spread Spectrum Feature

The device generates a clock that is frequency modulated in order to increase the bandwidth that it occupies. By increasing the bandwidth of the fundamental and its harmonics, the amplitudes of the radiated electromagnetic emissions are reduced. This effect is depicted in *Figure 1*.

As shown in *Figure 1*, a harmonic of a modulated clock has a much lower amplitude than that of an unmodulated signal. The reduction in amplitude is dependent on the harmonic number and the frequency deviation or spread. The equation for the reduction is

$$dB = 6.5 + 9 \cdot \log_{10}(P) + 9 \cdot \log_{10}(F)$$

Where P is the percentage of deviation and F is the frequency in MHz where the reduction is measured.

The output clock is modulated with a waveform depicted in *Figure 2*. This waveform, as discussed in "Spread Spectrum Clock Generation for the Reduction of Radiated Emissions" by Bush, Fessler, and Hardin produces the maximum reduction in the amplitude of radiated electromagnetic emissions. The deviation selected for this chip is -0.5% downspread. *Figure 2* details the Cypress spreading pattern. Cypress does offer options with more spread and greater EMI reduction. Contact your local Sales representative for details on these devices.

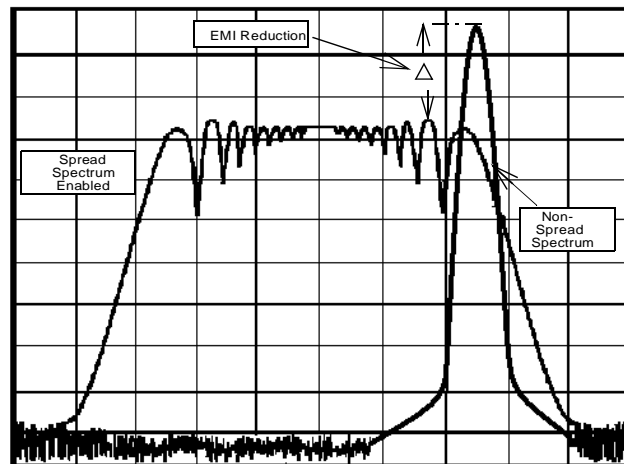

Figure 1. Typical Clock and SSFTG Comparison

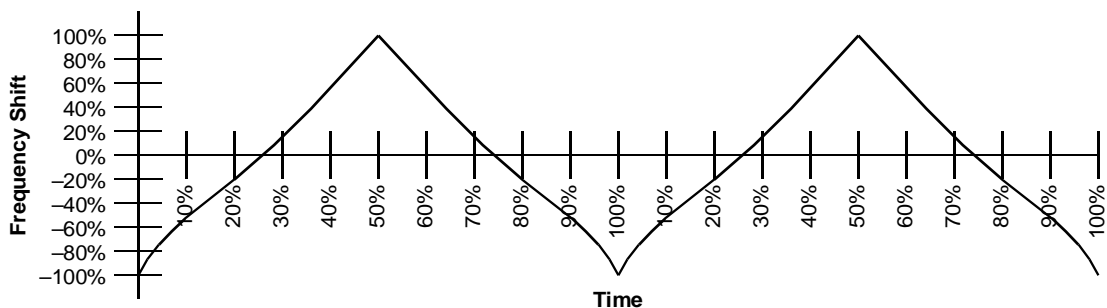

Figure 2. Typical Modulation Profile

Absolute Maximum Ratings

Stresses greater than those listed in this table may cause permanent damage to the device. These represent a stress rating only. Operation of the device at these or any other conditions

above those specified in the operating sections of this specification is not implied. Maximum conditions for extended periods may affect reliability.

| Parameter | Description | Rating | Unit |
|------------------|--|--------------|------|
| V_{DD}, V_{IN} | Voltage on any pin with respect to GND | -0.5 to +7.0 | V |
| T_{STG} | Storage Temperature | -65 to +150 | °C |
| T_A | Operating Temperature | 0 to +70 | °C |
| T_B | Ambient Temperature under Bias | -55 to +125 | °C |
| ESD_{PROT} | Input ESD Protection | 2 (min.) | kV |

DC Electrical Characteristics: $T_A = 0^\circ\text{C}$ to $+70^\circ\text{C}$, $V_{DDQ3} = 3.3\text{V} \pm 5\%$, $V_{DDQ2} = 2.5\text{V} \pm 5\%$

| Parameter | Description | Test Condition | Min. | Typ. | Max. | Unit |
|--|--|---------------------------------|-------------|-------------|----------------|-------------|
| Supply Current | | | | | | |
| $I_{DD-3.3V}$ | Combined 3.3V Supply Current | CPU0:3 = 133 MHz ^[2] | | | 160 | mA |
| $I_{DD-2.5}$ | Combined 2.5V Supply Current | CPU0:3 = 133 MHz ^[2] | | | 90 | mA |
| Logic Inputs (All referenced to $V_{DDQ3} = 3.3V$) | | | | | | |
| V_{IL} | Input Low Voltage | | GND - 0.3 | | 0.8 | V |
| V_{IH} | Input High Voltage | | 2.0 | | $V_{DD} + 0.3$ | V |
| I_{IL} | Input Low Current ^[3] | | | | -25 | μA |
| I_{IH} | Input High Current ^[3] | | | | 10 | μA |
| I_{IL} | Input Low Current, SEL133/100# ^[3] | | | | -5 | μA |
| I_{IH} | Input High Current, SEL133/100# ^[3] | | | | 5 | μA |
| Clock Outputs | | | | | | |
| CPU, CPUdiv2, IOAPIC (Referenced to V_{DDQ2}) | | Test Condition | Min. | Typ. | Max. | Unit |
| V_{OL} | Output Low Voltage | $I_{OL} = 1\text{ mA}$ | | | 50 | mV |
| V_{OH} | Output High Voltage | $I_{OH} = -1\text{ mA}$ | 2.2 | | | V |
| I_{OL} | Output Low Current | $V_{OL} = 1.25V$ | 45 | 65 | 100 | mA |
| I_{OH} | Output High Current | $V_{OH} = 1.25V$ | 45 | 65 | 100 | mA |
| 48MHz, REF (Referenced to V_{DDQ3}) | | Test Condition | Min. | Typ. | Max. | Unit |
| V_{OL} | Output Low Voltage | $I_{OL} = 1\text{ mA}$ | | | 50 | mV |
| V_{OH} | Output High Voltage | $I_{OH} = -1\text{ mA}$ | 3.1 | | | V |
| I_{OL} | Output Low Current | $V_{OL} = 1.5V$ | 45 | 65 | 100 | mA |
| I_{OH} | Output High Current | $V_{OH} = 1.5V$ | 45 | 65 | 100 | mA |
| PCI, 3V66 (Referenced to V_{DDQ3}) | | Test Condition | Min. | Typ. | Max. | Unit |
| V_{OL} | Output Low Voltage | $I_{OL} = 1\text{ mA}$ | | | 50 | mV |
| V_{OH} | Output High Voltage | $I_{OH} = -1\text{ mA}$ | 3.1 | | | V |
| I_{OL} | Output Low Current | $V_{OL} = 1.5V$ | 70 | 100 | 145 | mA |
| I_{OH} | Output High Current | $V_{OH} = 1.5V$ | 65 | 95 | 135 | mA |

Notes:

- All clock outputs loaded with 6" 60Ω transmission lines with 20-pF capacitors.
- W161 logic inputs have internal pull-up devices, except SEL133/100# (pull-ups not CMOS level).

DC Electrical Characteristics: $T_A = 0^{\circ}\text{C}$ to $+70^{\circ}\text{C}$, $V_{DDQ3} = 3.3\text{V}\pm 5\%$, $V_{DDQ2} = 2.5\text{V}\pm 5\%$ (continued)

| Parameter | Description | Test Condition | Min. | Typ. | Max. | Unit |
|-----------------------------------|--|--------------------|------|------|------|------|
| Crystal Oscillator | | | | | | |
| V_{TH} | X1 Input threshold Voltage ^[4] | | | 1.65 | | V |
| C_{LOAD} | Load Capacitance, Imposed on External Crystal ^[5] | | | 18 | | pF |
| $C_{IN,X1}$ | X1 Input Capacitance ^[6] | Pin X2 unconnected | | 28 | | pF |
| Pin Capacitance/Inductance | | | | | | |
| C_{IN} | Input Pin Capacitance | Except X1 and X2 | | | 5 | pF |
| C_{OUT} | Output Pin Capacitance | | | | 6 | pF |
| L_{IN} | Input Pin Inductance | | | | 7 | nH |

3.3V AC Electrical Characteristics

 $T_A = 0^{\circ}\text{C}$ to $+70^{\circ}\text{C}$, $V_{DDQ3} = 3.3\text{V}\pm 5\%$, $V_{DDQ2} = 2.5\text{V}\pm 5\%$, $f_{XTL} = 14.31818\text{ MHz}$
Spread Spectrum function turned off

AC clock parameters are tested and guaranteed over stated operating conditions using the stated lump capacitive load at the clock output.^[7]

3V66 Clock Outputs, 3V66_0:3 (Lump Capacitance Test Load = 30 pF)

| Parameter | Description | Test Condition/Comments | Min. | Typ. | Max. | Unit |
|-----------|--|---|------|------|------|----------|
| f | Frequency | Note 8 | | 66.6 | | MHz |
| t_R | Output Rise Edge Rate | Measured from 0.4V to 2.4V | 1 | | 4 | V/ns |
| t_F | Output Fall Edge Rate | Measured from 2.4V to 0.4V | 1 | | 4 | V/ns |
| t_D | Duty Cycle | Measured on rising and falling edge at 1.5V | 45 | | 55 | % |
| f_{ST} | Frequency Stabilization from Power-up (cold start) | Assumes full supply voltage reached within 1 ms from power-up. Short cycles exist prior to frequency stabilization. | | | 3 | ms |
| Z_o | AC Output Impedance | Average value during switching transition. Used for determining series termination value. | | 15 | | Ω |

Notes:

4. X1 input threshold voltage (typical) is $V_{DD}/2$.
5. The W161 contains an internal crystal load capacitor between pin X1 and ground and another between pin X2 and ground. Total load placed on crystal is 18 pF; this includes typical stray capacitance of short PCB traces to crystal.
6. X1 input capacitance is applicable when driving X1 with an external clock source (X2 is left unconnected).
7. Period, jitter, offset, and skew measured on rising edge at 1.5V.
8. 3V66 is CPU/2 for CPU = 133 MHz and (2 x CPU)/3 for CPU = 100 MHz.

PCI Clock Outputs, PCI0:9 (Lump Capacitance Test Load = 30 pF)

| Parameter | Description | Test Condition/Comments | Min. | Typ. | Max. | Unit |
|-----------|--|---|------|------|------|----------|
| t_P | Period | Measured on rising edge at 1.5V ^[9] | 30 | | | ns |
| t_H | High Time | Duration of clock cycle above 2.4V | 12 | | | ns |
| t_L | Low Time | Duration of clock cycle below 0.4V | 12 | | | ns |
| t_R | Output Rise Edge Rate | Measured from 0.4V to 2.4V | 1 | | 4 | V/ns |
| t_F | Output Fall Edge Rate | Measured from 2.4V to 0.4V | 1 | | 4 | V/ns |
| t_D | Duty Cycle | Measured on rising and falling edge at 1.5V | 45 | | 55 | % |
| t_{JC} | Jitter, Cycle-to-Cycle | Measured on rising edge at 1.5V. Maximum difference of cycle time between two adjacent cycles. | | | 500 | ps |
| t_{SK} | Output Skew | Measured on rising edge at 1.5V. | | | 500 | ps |
| t_O | 3V66 to PCI Clock Skew | Covers all 3V66/PCI outputs. Measured on rising edge at 1.5V. 3V66 leads PCI output. | 1.5 | | 3 | ns |
| f_{ST} | Frequency Stabilization from Power-up (cold start) | Assumes full supply voltage reached within 1 ms from power-up. Short cycles exist prior to frequency stabilization. | | | 3 | ms |
| Z_O | AC Output Impedance | Average value during switching transition. Used for determining series termination value. | | 15 | | Ω |

REF Clock Outputs, REF0:1 (Lump Capacitance Test Load = 20 pF)

| Parameter | Description | Test Condition/Comments | Min. | Typ. | Max. | Unit |
|-----------|--|---|------|--------|------|----------|
| f | Frequency, Actual | Frequency generated by crystal oscillator | | 14.318 | | |
| t_R | Output Rise Edge Rate | Measured from 0.4V to 2.4V | 0.5 | | 2 | V/ns |
| t_F | Output Fall Edge Rate | Measured from 2.4V to 0.4V | 0.5 | | 2 | V/ns |
| t_D | Duty Cycle | Measured on rising and falling edge at 1.5V | 45 | | 55 | % |
| f_{ST} | Frequency Stabilization from Power-up (cold start) | Assumes full supply voltage reached within 1 ms from power-up. Short cycles exist prior to frequency stabilization. | | | 3 | ms |
| Z_O | AC Output Impedance | Average value during switching transition. Used for determining series termination value. | | 25 | | Ω |

48-MHZ Clock Output (Lump Capacitance Test Load = 20 pF)

| Parameter | Description | Test Condition/Comments | Min. | Typ. | Max. | Unit |
|-----------|--|---|------|--------|------|----------|
| f | Frequency, Actual | Determined by PLL divider ratio (see m/n below) | | 48.008 | | MHz |
| f_D | Deviation from 48 MHz | $(48.008 - 48)/48$ | | +167 | | ppm |
| m/n | PLL Ratio | $(14.31818 \text{ MHz} \times 57/17 = 48.008 \text{ MHz})$ | | 57/17 | | |
| t_R | Output Rise Edge Rate | Measured from 0.4V to 2.4V | 0.5 | | 2 | V/ns |
| t_F | Output Fall Edge Rate | Measured from 2.4V to 0.4V | 0.5 | | 2 | V/ns |
| t_D | Duty Cycle | Measured on rising and falling edge at 1.5V | 45 | | 55 | % |
| f_{ST} | Frequency Stabilization from Power-up (cold start) | Assumes full supply voltage reached within 1 ms from power-up. Short cycles exist prior to frequency stabilization. | | | 3 | ms |
| Z_O | AC Output Impedance | Average value during switching transition. Used for determining series termination value. | | 25 | | Ω |

Note:

9. PCI clock is CPU/4 for CPU = 133 MHz and CPU/3 for CPU = 100 MHz.

2.5V AC Electrical Characteristics
 $T_A = 0^\circ\text{C to } +70^\circ\text{C}$, $V_{DDQ3} = 3.3\text{V} \pm 5\%$, $V_{DDQ2} = 2.5\text{V} \pm 5\%$
 $f_{XTL} = 14.31818 \text{ MHz}$

Spread Spectrum function turned off

 AC clock parameters are tested and guaranteed over stated operating conditions using the stated lump capacitive load at the clock output.^[10]
CPU Clock Outputs, CPU0:2 (Lump Capacitance Test Load = 20 pF)

| Parameter | Description | Test Condition/Comments | CPU = 133 MHz | | | CPU = 100 MHz | | | Unit |
|-----------|--|---|---------------|------|------|---------------|------|------|------|
| | | | Min. | Typ. | Max. | Min. | Typ. | Max. | |
| t_P | Period | Measured on rising edge at 1.25V | 7.5 | | 7.65 | 10 | | 10.2 | ns |
| t_H | High Time | Duration of clock cycle above 2.0V | 1.87 | | | 3.0 | | | ns |
| t_L | Low Time | Duration of clock cycle below 0.4V | 1.67 | | | 2.8 | | | ns |
| t_R | Output Rise Edge Rate | Measured from 0.4V to 2.0V | 1 | | 4 | 1 | | 4 | V/ns |
| t_F | Output Fall Edge Rate | Measured from 2.0V to 0.4V | 1 | | 4 | 1 | | 4 | V/ns |
| t_D | Duty Cycle | Measured on rising and falling edge at 1.25V | 45 | | 55 | 45 | | 55 | % |
| t_{JC} | Jitter, Cycle-to-Cycle | Measured on rising edge at 1.25V. Maximum difference of cycle time between two adjacent cycles. | | | 250 | | | 250 | ps |
| t_{SK} | Output Skew | Measured on rising edge at 1.25V | | | 175 | | | 175 | ps |
| f_{ST} | Frequency Stabilization from Power-up (cold start) | Assumes full supply voltage reached within 1 ms from power-up. Short cycles exist prior to frequency stabilization. | | | 3 | | | 3 | ms |

CPUdiv2 Clock Outputs, CPUdiv2 (Lump Capacitance Test Load = 20 pF)

| Parameter | Description | Test Condition/Comments | CPU = 133 MHz | | | CPU = 100 MHz | | | Unit |
|-----------|--|---|---------------|------|------|---------------|------|------|----------|
| | | | Min. | Typ. | Max. | Min. | Typ. | Max. | |
| t_P | Period | Measured on rising edge at 1.25V | 15 | | 15.3 | 20 | | 20.4 | ns |
| t_H | High Time | Duration of clock cycle above 2.0V | 5.25 | | | 7.5 | | | ns |
| t_L | Low Time | Duration of clock cycle below 0.4V | 5.05 | | | 7.3 | | | ns |
| t_R | Output Rise Edge Rate | Measured from 0.4V to 2.0V | 1 | | 4 | 1 | | 4 | V/ns |
| t_F | Output Fall Edge Rate | Measured from 2.0V to 0.4V | 1 | | 4 | 1 | | 4 | V/ns |
| t_D | Duty Cycle | Measured on rising and falling edge at 1.25V | 45 | | 55 | 45 | | 55 | % |
| t_{JC} | Jitter, Cycle-to-Cycle | Measured on rising edge at 1.25V. Maximum difference of cycle time between two adjacent cycles. | | | 250 | | | 250 | ps |
| t_{SK} | Output Skew | Measured on rising edge at 1.25V | | | 175 | | | 175 | ps |
| f_{ST} | Frequency Stabilization from Power-up (cold start) | Assumes full supply voltage reached within 1 ms from power-up. Short cycles exist prior to frequency stabilization. | | | 3 | | | 3 | ms |
| Z_o | AC Output Impedance | Average value during switching transition. Used for determining series termination value. | | 20 | | | 20 | | Ω |

Note:

10. Period, Jitter, offset, and skew measured on rising edge at 1.25V.

IOAPIC Clock Output, IOAPIC (Lump Capacitance Test Load = 20 pF)

| Parameter | Description | Test Condition/Comments | Min | Typ | Max | Unit |
|-----------------|--|---|-----|-------|-----|------|
| f | Frequency | Note 11 | | 16.67 | | MHz |
| t _R | Output Rise Edge Rate | Measured from 0.4V to 2.0V | 1 | | 4 | V/ns |
| t _F | Output Fall Edge Rate | Measured from 2.0V to 0.4V | 1 | | 4 | V/ns |
| t _D | Duty Cycle | Measured on rising and falling edge at 1.25V | 45 | | 55 | % |
| f _{ST} | Frequency Stabilization from Power-up (cold start) | Assumes full supply voltage reached within 1 ms from power-up. Short cycles exist prior to frequency stabilization. | | | 3 | ms |
| Z _O | AC Output Impedance | Average value during switching transition. Used for determining series termination value. | | 20 | | Ω |

Note:

11. IOAPIC clock is CPU/8 for CPU = 133 MHz and CPU/6 for CPU = 100 MHz.

Ordering Information

| Ordering Code | Package Name | Package Type |
|---------------|--------------|------------------------|
| W161 | H | 48-pin SSOP (300 mils) |

Document #: 38-00817

Package Diagram

48-Pin Small Shrink Outline Package (SSOP, 300 mils)

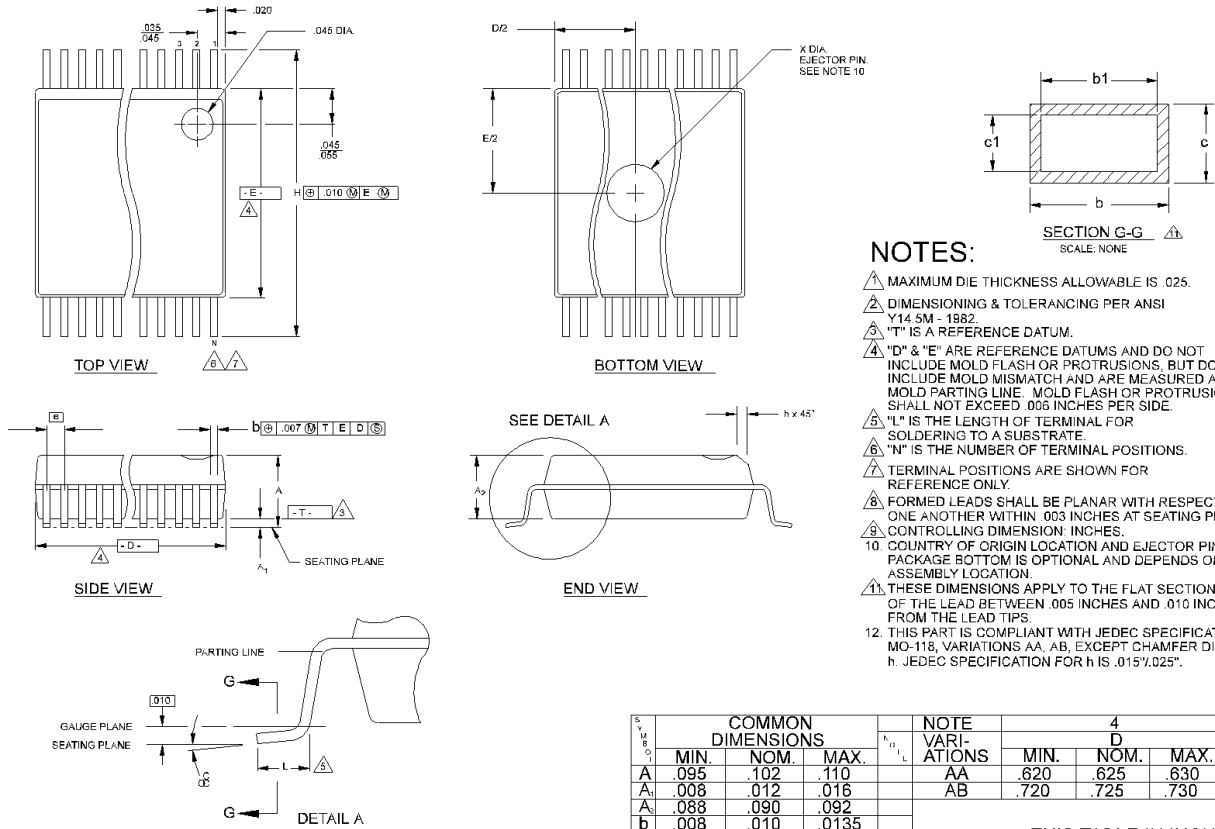

NOTES:

- 1. MAXIMUM DIE THICKNESS ALLOWABLE IS .025.
- 2. DIMENSIONING & TOLERANCING PER ANSI Y14.5M - 1982.
- 3. "T" IS A REFERENCE DATUM.
- 4. "D" & "E" ARE REFERENCE DATUMS AND DO NOT INCLUDE MOLD FLASH OR PROTRUSIONS, BUT DOES INCLUDE MOLD MISMATCH AND ARE MEASURED AT THE MOLD PARTING LINE. MOLD FLASH OR PROTRUSIONS SHALL NOT EXCEED .006 INCHES PER SIDE.
- 5. "L" IS THE LENGTH OF TERMINAL FOR SOLDERING TO A SUBSTRATE.
- 6. "N" IS THE NUMBER OF TERMINAL POSITIONS.
- 7. TERMINAL POSITIONS ARE SHOWN FOR REFERENCE ONLY.
- 8. FORMED LEADS SHALL BE PLANAR WITH RESPECT TO ONE ANOTHER WITHIN .003 INCHES AT SEATING PLANE.
- 9. CONTROLLING DIMENSION INCHES.
- 10. COUNTRY OF ORIGIN LOCATION AND EJECTOR PIN ON PACKAGE BOTTOM IS OPTIONAL AND DEPENDS ON ASSEMBLY LOCATION.
- 11. THESE DIMENSIONS APPLY TO THE FLAT SECTION OF THE LEAD BETWEEN .005 INCHES AND .010 INCHES FROM THE LEAD TIPS.
- 12. THIS PART IS COMPLIANT WITH JEDEC SPECIFICATION MO-118, VARIATIONS AA, AB, EXCEPT CHAMFER DIMENSION h. JEDEC SPECIFICATION FOR h IS .015"±.025".

Summary of nominal dimensions in inches:

Body Width: 0.296
Lead Pitch: 0.025
Body Length: 0.625
Body Height: 0.102

| SYMBOL | COMMON DIMENSIONS | | | NOTE VARIATIONS | 4 D | | | 6 N |
|----------------|-------------------|------|-------|-----------------|------|------|------|-----|
| | MIN. | NOM. | MAX. | | MIN. | NOM. | MAX. | |
| A | .095 | .102 | .110 | AA | .620 | .625 | .630 | 48 |
| A ₁ | .088 | .090 | .092 | AB | .720 | .725 | .730 | 56 |
| b | .008 | .010 | .0135 | | | | | |
| b ₁ | .008 | .010 | .012 | | | | | |
| c | .005 | - | .010 | | | | | |
| c ₁ | .005 | .006 | .0085 | | | | | |
| D | SEE VARIATIONS | | | 4 | | | | |
| E | .292 | .296 | .299 | | | | | |
| e | .025 BSC | | | | | | | |
| H | .400 | .406 | .410 | | | | | |
| h | .010 | .013 | .016 | | | | | |
| L | .024 | .032 | .040 | | | | | |
| N | SEE VARIATIONS | | | 6 | | | | |
| X | .085 | .093 | .100 | 10 | | | | |
| α | 0° | 5° | 8° | | | | | |

THIS TABLE IN INCHES

| SYMBOL | COMMON DIMENSIONS | | | NOTE VARIATIONS | 4 D | | | 6 N |
|----------------|-------------------|-------|-------|-----------------|-------|-------|-------|-----|
| | MIN. | NOM. | MAX. | | MIN. | NOM. | MAX. | |
| A | 2.41 | 2.59 | 2.79 | AA | 15.75 | 15.88 | 16.00 | 48 |
| A ₁ | 0.20 | 0.31 | 0.41 | AB | 18.29 | 18.42 | 18.54 | 56 |
| A ₂ | 2.24 | 2.29 | 2.34 | | | | | |
| b | 0.203 | 0.254 | 0.343 | | | | | |
| b ₁ | 0.203 | 0.254 | 0.305 | | | | | |
| c | 0.127 | - | 0.254 | | | | | |
| c ₁ | 0.127 | 0.152 | 0.216 | | | | | |
| D | SEE VARIATIONS | | | 4 | | | | |
| E | 7.42 | 7.52 | 7.59 | | | | | |
| e | 0.635 BSC | | | | | | | |
| H | 10.16 | 10.31 | 10.41 | | | | | |
| h | 0.25 | 0.33 | 0.41 | | | | | |
| L | 0.61 | 0.81 | 1.02 | | | | | |
| N | SEE VARIATIONS | | | 6 | | | | |
| X | 2.16 | 2.36 | 2.54 | 10 | | | | |
| α | 0° | 5° | 8° | | | | | |

THIS TABLE IN MILLIMETERS