

## 1.0 DESCRIPTION

### 1.1 FEATURES

- Two fully programmable and independent serial I/O ports configurable as PC/AT compatible (WD16C452) or PS/2 compatible (WD16C552)
  - Loopback controls for communications link fault isolation for each ACE
  - Line break generation and detection for each ACE
  - Complete status reporting capabilities
  - Generation and stripping of serial asynchronous data control bits (start, stop, parity)
  - Programmable baud rate generator and MODEM control signals for each port
  - Programmable baud rate generator input clock
  - Optional 16 byte FIFO buffers on both transmit and receive of each port for CPU relief during high speed data transfer
  - Programmable FIFO threshold levels of 1, 4, 8, or 14 bytes on each port
- Parallel port configurable as a fully Centronics or PS/2 compatible, bidirectional parallel port
- Independently programmable parallel port
- Interrupt multiplexing logic
  - Selectable multiplexing logic for connecting PC/AT interrupt request lines to the WD76C10 single chip AT controller
- Clock generation circuitry
  - 80287 coprocessor clock generation
  - WD76C10 and floppy controller clock generation
  - 8042 keyboard clock generation
- Built-in testability features
- Hardware or software controllable sleep mode
- CMOS implementation for high speed and low power requirements
- Pulse extension on IRQ inputs
- 84-pin PLCC and PQFP packages

### 1.2 GENERAL

The WD76C30 device provides three functional groups. It is a Peripheral Controller, Interrupt Multiplexer, and Clock Generator.

The low power CMOS WD76C30 is a single device solution which provides interrupt multiplexing logic, clock generation, two serial ports, and one bidirectional parallel port.

Interrupt multiplexing logic interfaces the PC/AT interrupt request lines with the WD76C10 Single Chip AT Controller.

Integrated clock generation circuitry uses the 48 MHz input signal to generate the 1.8462, 3.072, and 8.0 MHz clocks used internally for the two serial ports, a 9.6 MHz signal used for the keyboard controller and floppy controller, a programmable duty/frequency clock for the 80287 coprocessor, and a 16 MHz clock for driving the WD76C10 Single Chip AT Controller, and floppy controller.

For low power implementations such as laptops, oscillator disable and sleep modes are available to power down unused logic.

The bidirectional parallel port is software configurable as either a PC/AT or a PS/2 compatible port. The parallel port data lines and open drain printer signals have high current drive capabilities.

Each ACE is programmable as either a WD16C550 or WD16C450 compatible device. Each WD16C550 configured ACE is capable of buffering up to 16 bytes of data upon reception, relieving the CPU of interrupt overhead. Buffering of data also allows greater latency time in interrupt servicing which is vital in a multitasking environment. Each ACE has a maximum recommended data rate of 512 Kbaud.

1.3 PERIPHERAL CONTROLLER

The peripheral controller is functionally equivalent to the WD16C452/552. The mode of operation of the serial ports and parallel port is selectable via the Mode Select Register. Each serial port is configurable as either a FIFO enhanced ACE

(WD16C550 compatible) or a standard ACE (WD16C450). The parallel port is configurable as either a PS/2 bidirectional parallel port or a PC/AT compatible parallel port. A detailed description of the Mode Selection Register is described in the parallel port section.

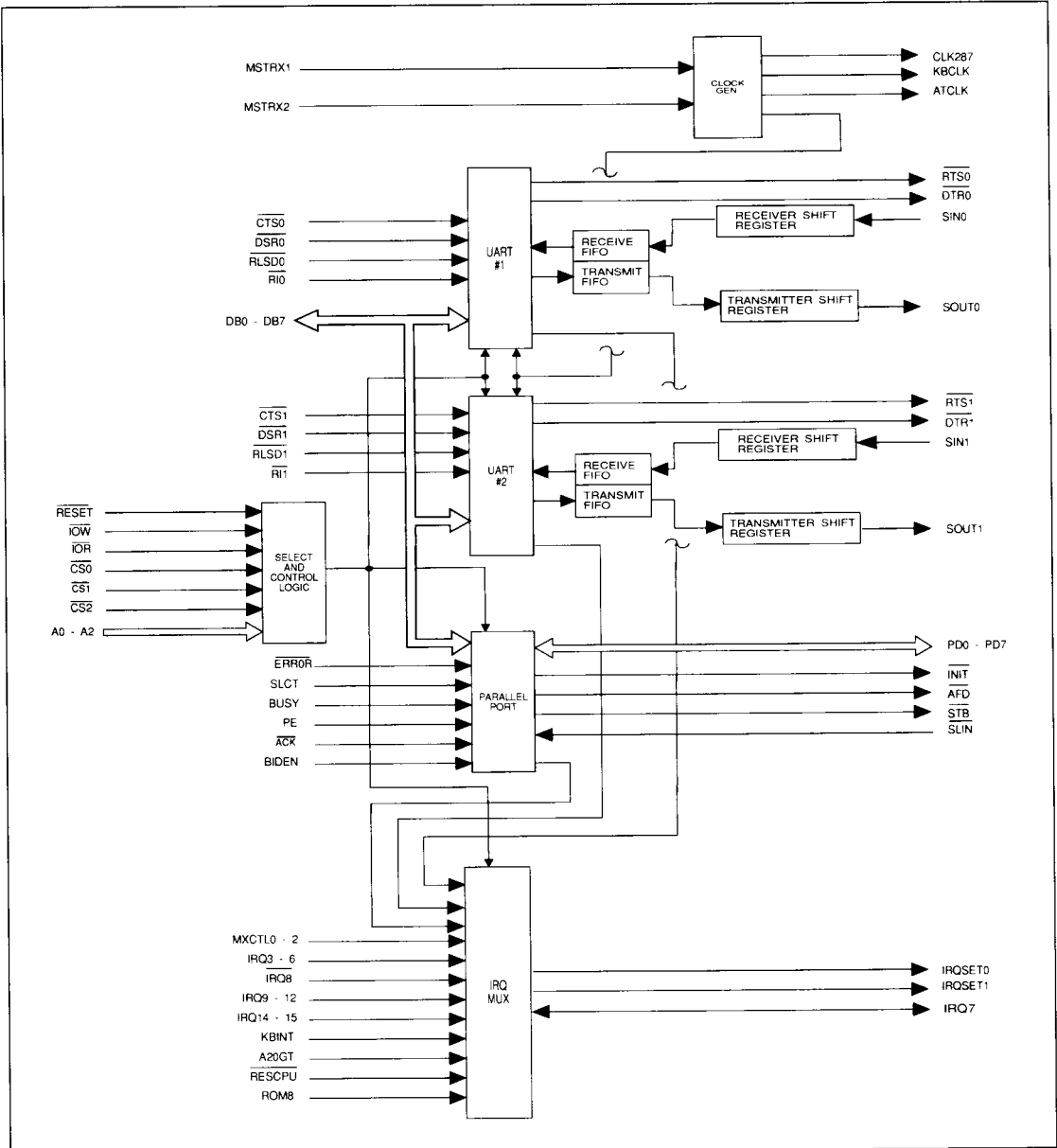

FIGURE 1-1. WD76C30 BLOCK DIAGRAM



## 2.0 PIN DESCRIPTION

Table 2-1 provides a description of the signals serviced by the WD76C30. A drawing of the 84-pin QUAD package, showing the pin and signal loca-

tions, is provided in Figure 2-1. The DC operating characteristics and timing are presented in section 6.

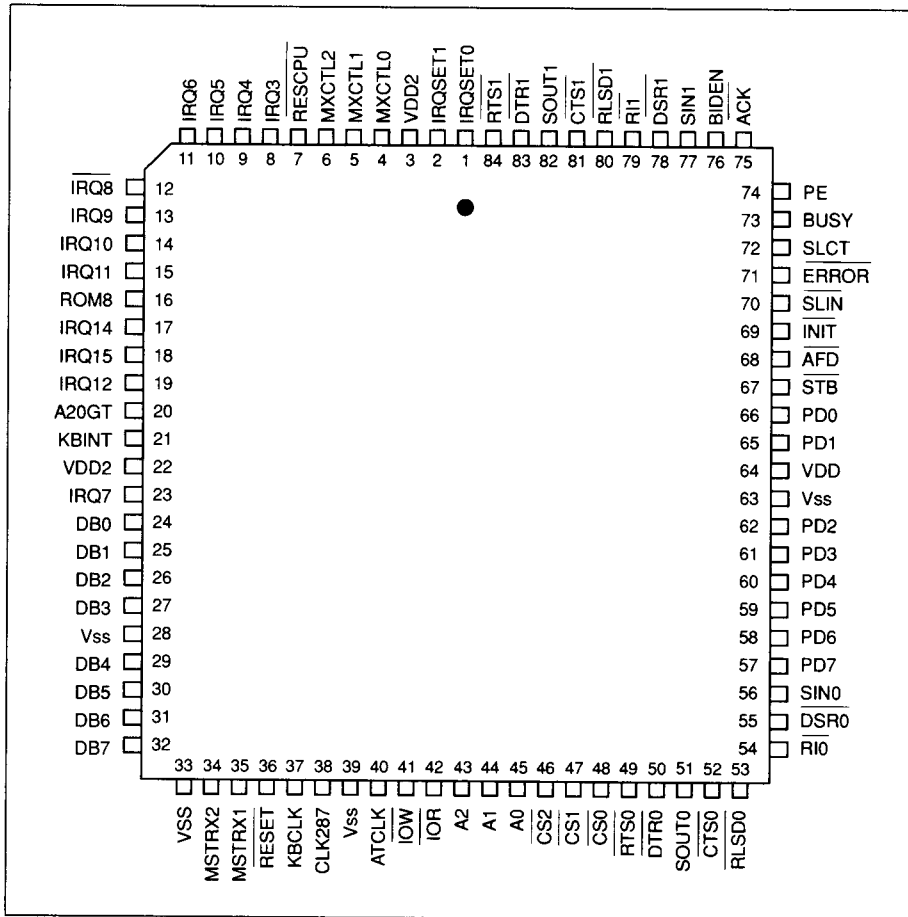

FIGURE 2-1. 84-PIN PLCC - SIGNAL/PIN ASSIGNMENT



PIN NUMBER	MNEMONIC	SIGNAL NAME	I/O	DESCRIPTION
76	BIDEN	Bidirectional Enable	I	When de-asserted, the BIDEN enables the parallel port data lines as outputs. When asserted, BIDEN works in conjunction with the DIR bit (see Table 4-3) to control the direction of the parallel port data bit.
78, 55	$\overline{\text{DSR1}}, \overline{\text{DSR0}}$	$\overline{\text{Data Set Ready}}$	I	The communication link asserts these signals to indicate that it is ready to exchange data with the associated Asynchronous Communications Element (ACE). Bit 5 of the associated MODEM Status Register reflects the logical state of DSR.
79, 54	$\overline{\text{RI1}}, \overline{\text{RI0}}$	$\overline{\text{Ring Indicator}}$	I	When asserted, these signals indicate that a ringing signal for the associated ACE is being received by the MODEM or data set. This logical value is reflected in bit 6 of the associated MODEM Status Register.
80 53	$\overline{\text{RLSD1}}$ $\overline{\text{RLSD0}}$	$\overline{\text{Received Line Signal Detect}}$	I	The Data Circuit-terminating Equipment (DCE) asserts these signals when the associated ACE is receiving a signal that meets its signal quality conditions. Bit 3 of the associated MODEM Status Register reflects this value.
82 51	SOUT1 SOUT0	Serial Data Output	O	SOUT1 is the transmitted Serial Data Output from ACE#1 to the communication link. SOUT0 is the transmitted Serial Data Output from ACE#0 to the communication link. The SOUT signals are set to a marking condition (logical 1) upon a Master Reset.
77, 56	SIN1, SIN0	Serial Data Inputs	I	SIN1 is the received Serial Data Input from the communication link to ACE#1. SIN0 is the received Serial Data Input from the communication link to ACE#0.  Data on the serial data inputs are disabled when exercising loop back mode and internally connected to their respective SOUT lines.
83, 50	$\overline{\text{DTR1}}, \overline{\text{DTR0}}$	$\overline{\text{Data Terminal Ready}}$	O	When asserted, the Data Terminal Ready informs the MODEM or data set that the associated ACE is ready to receive. This value is reflected in bit 0 of the MODEM Control Register.
84, 49	$\overline{\text{RTS1}}, \overline{\text{RTS0}}$	$\overline{\text{Request To Send}}$	O	When asserted, the $\overline{\text{Request To Send}}$ informs the MODEM or data set that the associated ACE is ready to transmit data. This value is reflected in bit 1 of the MODEM Control Register.

TABLE 2-1. PIN DESCRIPTION



PIN NUMBER	MNEMONIC	SIGNAL NAME	I/O	DESCRIPTION
81, 52	$\overline{\text{CTS1}}, \overline{\text{CTS0}}$	$\overline{\text{Clear to Send}}$	I	The DCE asserts the $\overline{\text{Clear To Send}}$ to signal the associated ACE that a remote device is ready to transmit. This value is reflected in bit 4 of the MODEM Status Register.
32 - 29, 27 - 24	DB7 - DB0	Data Bits	I/O	The Data Bits are tri-state, bidirectional communication lines between the WD76C30 and Data Bus.  DB0 is the least significant bit and the first serial bit to be transmitted or received.
43 - 45	A2, A1, A0	Address lines A2-A0	I	Address Lines A2 - A0 are used to select the registers internal to the WD76C30.
41	$\overline{\text{IOW}}$	$\overline{\text{Input/Output Write Strobe}}$	I	When $\overline{\text{Input/Output Write Strobe}}$ is asserted, data is written to the Port's addressed register from the Data Bus (DB7 - DB0). The register is addressed by Address Lines A2 - A0. ACE#0, ACE#1, or the Parallel Port is selected by CS0, CS1, or CS2 respectively.
42	$\overline{\text{IOR}}$	$\overline{\text{Input/Output Read Strobe}}$	I	When $\overline{\text{Input/Output Read Strobe}}$ is asserted, data is read from the Port's addressed register and placed on the Data Bus (DB7 - DB0). The register is addressed by Address Lines A2 - A0. ACE#0, ACE#1, or the Parallel Port is selected by CS0, CS1, or CS2 respectively.
48	$\overline{\text{CS0}}$	$\overline{\text{Chip Select 0}}$	I	$\overline{\text{Chip Select 0}}$ when asserted, selects serial port 0.
47	$\overline{\text{CS1}}$	$\overline{\text{Chip Select 1}}$	I	$\overline{\text{Chip Select 1}}$ when asserted, selects serial port 1.
46	$\overline{\text{CS2}}$	$\overline{\text{Chip Select 2}}$	I	$\overline{\text{Chip Select 2}}$ when asserted, enables the parallel port.
36	$\overline{\text{RESET}}$	$\overline{\text{Reset}}$	I	When asserted, $\overline{\text{RESET}}$ forces the WD76C30 into an idle mode in which all serial data activities are terminated. The IRQ MUX is forced into a non-compatible mode. The WD76C30 remains in the idle state until programmed to begin data activities.
57 - 62, 65 - 66	PD7 - PD0	Parallel Data Bits	I/O	Bidirectional data port, providing parallel input and output to the parallel port.

TABLE 2-1. PIN DESCRIPTIONS Cont.



PIN NUMBER	MNEMONIC	SIGNAL NAME	I/O	DESCRIPTION
67	STB ①	<u>Line Printer Strobe</u>	O	When asserted, the <u>Line Printer Strobe</u> signals the line printer to latch the data currently on the parallel port (PD7 - PD0).
68	<u>AFD</u> ①	<u>Line Printer Autofeed</u>	O	When asserted, the <u>Line Printer Autofeed</u> signals the line printer to autofeed continuous form paper.
69	<u>INIT</u> ①	<u>Line Printer Initialize</u>	O	When asserted, <u>Line Printer Initialize</u> signals the line printer to begin an initialization routine.
70	<u>SLIN</u> ①	<u>Line Printer Select</u>	O	When asserted, <u>Line Printer Select</u> selects the printer.
23	IRQ7/ <u>IRQ7</u>	Interrupt Request 7	I/O	<p>IRQ7/<u>IRQ7</u> is an input to the IRQ MUX when the WD76C30 is <u>not</u> in the Stand Alone Mode.</p> <p>IRQ7/<u>IRQ7</u> is output as the Parallel Port Interrupt when the WD76C30 is in the Stand Alone Mode (refer to section 5.6, 5.7).</p> <p>When operating as the Parallel Port Interrupt, IRQ7/<u>IRQ7</u> is a tri-state signal and must be enabled by bit 4 in the Write Control Register (refer to section 4.0).</p> <p>When the Parallel Port Interrupt is PC/AT compatible, this signal is IRQ7 and is asserted at the rising edge of <u>ACK</u> and de-asserted at the falling edge of <u>ACK</u>.</p> <p>When the Parallel Port is PS/2 compatible, this signal is <u>IRQ7</u> and is asserted at the rising edge of <u>ACK</u> and de-asserted at the rising edge of <u>IOR</u>, when reading the Parallel Port Status Register.</p>
71	<u>ERROR</u>	<u>Line Printer Error</u>	I	The printer asserts this signal to inform the parallel port of a deselect condition, PE, or other error condition.
72	SLCT	Line Printer Select	I	The line printer asserts the Line Printer Select signal when it has been selected.
73	BUSY	Line Printer Busy	I	The line printer asserts the Line Printer Busy signal when it has an operation in progress.
74	PE	Line Printer Paper Empty	I	The line printer asserts the Line Printer Paper Empty signal when it is out of paper.

① These outputs are open drain with internal pull-ups.

TABLE 2-1. PIN DESCRIPTION Cont.



PIN NUMBER	MNEMONIC	SIGNAL NAME	I/O	DESCRIPTION
75	ACK	Line Printer Acknowledge	I	The line printer asserts the Line Printer Acknowledge signal to confirm that the data transfer from the WD76C30 to the printer was successful.
4 - 6	MXCTL0 - MXCTL2	IRQ MUX Control	I	MXCTL0 - MXCTL2 are encoded select signals generated by the WD76C10 for sampling the IRQ inputs.
8 - 15, 17-19	IRQ3 - 6 IRQ8 IRQ9-11 IRQ14, 15, 12	IRQ MUX Inputs	I	These 11 interrupt signals, along with <u>IRQ7</u> , <u>RESCPU</u> , <u>ROM8</u> , <u>KBINT</u> , and <u>A20GT</u> are multiplexed into <u>IRQSET0</u> and <u>IRQSET1</u> at a period rate defined by <u>MXCTL0</u> - <u>MXCTL2</u> .
7	RESCPU	Reset CPU	I	The keyboard controller asserts <u>Reset CPU</u> when the CPU should be reset.
16	ROM8	8-bit ROM	I	ROM8 is multiplexed into the <u>IRQSET1</u> signal and, when asserted, indicates to the WD76C10 that the system ROM is eight bits, when de-asserted it is 16 bits.
21	KBINT	Keyboard Interrupt	I	KBINT is multiplexed into the <u>IRQSET1</u> signal and indicates to the WD76C10 that a keyboard interrupt is pending.
20	A20GT	Address 20 Signal	I	A20GT is multiplexed into the <u>IRQSET1</u> signal and reflects the state of the address 20 signal. This allows compatibility with the 8086 and 80286 processors when addressing memory in the 64 Kbyte boundary above 1 Mbyte.
35	MSTRX1 ①	Master Clock 1	I	The Master Clock 1 signal can be driven by either a 16 MHz crystal or 48 MHz TTL oscillator.
34	MSTRX2 ①	Master Clock 2	O	Master Clock 2 is connected to the 16 MHz crystal to generate Master Clock 1 for the clock generation circuitry. This pin is left disconnected if Master Clock 1 is being driven by a 48 MHz TTL oscillator.
38	CLK287	80287 Clock	O	CLK287 clock drives the 80287 coprocessor. CLK287 is programmable via the Clock Selection Register. A variety of clock frequencies and duty cycles provide compatibility with a variety of 80287 or 80287 compatible coprocessors.

① Third overtone of 16 MHz crystal is used to generate the 48 MHz clock.

TABLE 2-1. PIN DESCRIPTION Cont.



PIN NUMBER	MNEMONIC	SIGNAL NAME	I/O	DESCRIPTION
37	KBCLK	Keyboard Clock	O	Keyboard Clock is a 9.6 MHz clock used to drive the keyboard controller. This signal can be used to drive the WD37C65 Floppy Disk Controller for systems not using the WD76C20 Storage Controller.
40	ATCLK	AT Clock	O	AT Clock is a 16 MHz clock used to drive the ATCLK input to the WD76C10. AT Clock provides a fixed reference that allows the PC/AT bus state machine to run with 8 MHz compatible timing. This signal can be used to drive the Floppy Disk Controller in the WD76C20 Storage Controller.
1 2	IRQSET0 IRQSET1	Interrupt Request Set 0, 1	O	These signals are outputs of the IRQ multiplexing logic. When in the Stand Alone Mode IRQSET0 and IRQSET1 become the tri-state interrupt outputs from Serial Port 0 and 1 respectively. (Refer to section 5.6)
64	VDD	Power Supply		+5V power supply to the serial and parallel port logic. This supply can be turned off.
3, 22	VDD2	Power Supply		+5V power supply to the WD76C30 with the exclusion of serial and parallel port logic.
28, 39, 63, 33	Vss	Ground		System signal ground.

TABLE 2-1. PIN DESCRIPTION Cont.





### 3.0 SERIAL PORT REGISTERS

The WD76C30 contains two serial ports, therefore, the following registers exist in duplicate, one per port.

#### 3.1 SERIAL PORT REGISTER ADDRESSING

##### 3.1.1 Chip Select ( $\overline{CS0}$ , $\overline{CS1}$ )

When  $\overline{CS0}$  is low, registers for serial port 0 can be accessed, and when  $\overline{CS1}$  is low, registers for serial port 1 can be accessed. No more than one  $\overline{CS}$  ( $\overline{CS0}$ ,  $\overline{CS1}$ , or  $\overline{CS2}$ ) should ever be low at any time, unless all three are low for Sleep Mode.

**Power Down Reset:**

In the Parallel Port, asserting Mode Selection Register bit 3 (PUD) described in section 5.5, causes the ACE to reset to the condition listed in Table 3-2.

**Software Reset:**

A software reset is performed by writing to the Divisor Latches, forcing the transmitter and receiver to an idle mode. Registers are not reset by this operation. Prior to enabling interrupts, the LSR and RBR registers should be read to clear out any data, returning them to a known state without resetting the system.

Chip Select ( $\overline{CS0}$ ,  $\overline{CS1}$ ) and register select (A0, A1, A2) signals must be stable for the duration of a read or write operation.

##### 3.1.2 Register Select (A0, A1, A2)

To select a register for read or write operation, see Table 3-1.

**NOTE**

Divisor Latch Access Bit (DLAB) is the MSB of the Line Control Register. DLAB must be programmed high (logic 1) by the system software to access the Baud Rate Generator Divisor Latches.

DLAB	A2	A1	A0	REGISTER
0	0	0	0	Receiver Buffer Register (read)
0	0	0	0	Transmitter Holding Register (write)
0	0	0	1	Interrupt Enable Register
X	0	1	0	Interrupt Identification Register (read)
X	0	1	0	FIFO Control Register (write)
X	0	1	1	Line Control Register
X	1	0	0	MODEM Control Register
X	1	0	1	Line Status Register (read only)
X	1	1	0	MODEM Status Register
X	1	1	1	Scratch Pad Register
1	0	0	0	Divisor Latch Register (least significant byte)
1	0	0	1	Divisor Latch Register (most significant byte)

TABLE 3-1. REGISTER ADDRESSING



## 3.2 ACE OPERATIONAL DESCRIPTION

## 3.2.2 ACE Accessible Registers

## 3.2.1 Master Reset

Asserting RESET on pin 36 causes the ACE to reset to the condition listed in Table 3-2.

The system programmer has access to any of the registers as summarized in Table 3-3. For individual register descriptions, refer to the following pages under register heading.

REGISTER/SIGNAL	RESET CONTROL	RESET STATE
Receiver Buffer Register	First Word Received	Data
Transmitter Holding Register	Writing into the Transmitter Holding Register	Data
Interrupt Enable Register	Master Reset or PUD = 1	All Bits Low (0-3 forced and 4-7 permanent)
Interrupt Identification Register	Master Reset or PUD = 1	Bit 0 is High and Bits 1-3; 6 and 7 are forced Low. Bits 4 and 5 are Permanently Low
Line Control Register	Master Reset or PUD = 1	All Bits Low
MODEM Control Register	Master Reset or PUD = 1	All Bits Low
Line Status Register	Master Reset or PUD = 1	All Bits Low, except Bits 5 and 6 are High
MODEM Status Register	Master Reset or PUD = 1 MODEM Signal Inputs	Bits 0-3 Low, Bits 4-7 at Input Signal
Divisor Latch (low order byte)	Writing into the Latch	Data
Divisor Latch (high order byte)	Writing into the Latch	Data
<u>SOUT</u>	Master Reset or PUD = 1	High
<u>RTS</u>	Master Reset or PUD = 1	High
<u>DTR</u>	Master Reset or PUD = 1	High
RCVR FIFO Counter	MR or FCR1 • FCR0 or ΔFCR0 or PUD = 1	All Bits Low
XMIT FIFO Counter	MR or FCR2 • FCR0 or ΔFCR0 or PUD = 1	All Bits Low
FIFO CONTROL	Master Reset or PUD = 1	All Bits Low
D7 - D0 Data Bus Lines	In Tristate Mode, Unless IOR = Low	Tri-State Data (ACE to CPU)
Address Selection Register	Master Reset	All Bits Low
Clock Selection Register	Master Reset	All Bits Low
CLK Disable Register	Master Reset	All Bits Low
Serial Port Interrupt Selection Register	Master Reset	All Bits Low
Serial Port Interrupt Selection Register	Master Reset	All Bits Low
Parallel Port Interrupt Selection Register	Master Reset	All Bits Low
Mode Selection Register	Master Reset	All Bits Low
Parallel Port Control	Master Reset or PUD = 1	Bits 7 - 6 High, Bits 5 - 0 Low
Parallel Port Data	Master Reset or PUD = 1	All Bits Low
Parallel Port Status	None	
<u>SLIN</u> , <u>INIT</u> , <u>AFD</u> , <u>STB</u> ,	Master Reset or PUD = 1	High, Low, High, High

\* Reset disables the Stand Alone Mode \*  
PUD is bit 3 of the Mode Selection Register

TABLE 3-2. RESET CONTROL OF REGISTERS AND PINOUT SIGNALS



REGISTER ADDRESS ②						
	DLAB = 0 A2-A0 = 0 Read Only	DLAB = 0 A2-A0 = 0 Write Only	DLAB = 0 A2-A0 = 1	DLAB = X A2-A0 = 2 Read Only	DLAB = X A2 - A0 = 2 Write Only	DLAB = X A2 - A0 = 3
REGISTER TITLE						
Bit No.	Receiver Buffer Register	Transmitter Holding Register	Interrupt Enable Register	Interrupt Identification Register	FIFO Control Register	Line Control Register
0	Data Bit 0	Data Bit 0	Enable Received Data Available Interrupt (ERBFI)	"0" if Interrupt Pending (IP)	FIFO Enable (FEWO)	Word Length Select Bit 0 (WLS0)
1	Data Bit 1	Data Bit 1	Enable Transmitter Holding Register Empty Interrupt (ETBEI)	Interrupt ID Bit 1 (IID)	Rcvr FIFO Reset (RFR)	Word Length Select Bit 1 (WLS1)
2	Data Bit 2	Data Bit 2	Enable Receiver Line Status Interrupt (ERLSI)	Interrupt ID Bit 2 (IID)	Transmitter FIFO Reset (TFR)	Number of Stop Bits (STB)
3	Data Bit 3	Data Bit 3	Enable MODEM Status Interrupt (EDSSI)	Interrupt ID Bit 3 (IID) ①	Not Used	Parity Enable (PEN)
4	Data Bit 4	Data Bit 4	0	0	Reserved	Even Parity Select (EPS)
5	Data Bit 5	Data Bit 5	0	0	Reserved	Stick Parity (STP)
6	Data Bit 6	Data Bit 6	0	FIFO Enabled ① (FERO)	Rcvr FIFO Trigger Level (LSB)(RFTL)	Set Break Control (SBR)
7	Data Bit 7	Data Bit 7	0	FIFO Enabled ① (FERO)	Rcvr FIFO Trigger Level (MSB) (RFTL)	Divisor Latch Access Bit (DLAB)

① These bits are 0 in Character Mode. ② See Table 3-1

TABLE 3-3. ACCESSIBLE WD76C30 SERIAL PORT REGISTERS



REGISTER ADDRESS ②						
	DLAB = X A2-A0 = 4	DLAB = X A2-A0 = 5	DLAB = X A2-A0 = 6	DLAB = X A2-A0 = 7	DLAB = 1 A2-A0 = 0	DLAB = 1 A2-A0 = 1
REGISTER TITLE						
Bit No.	MODEM Control Register	Line Status Register	MODEM Status Register	Scratch Pad Register	Divisor Latch (LSB)	Divisor Latch (MSB)
0	Data Terminal Ready (DTR)	Data Ready (DR)	Delta Clear to Send (DCTS)	Bit 0	Bit 0	Bit 8
1	Request to Send (RTS)	Overrun Error (OE)	Delta Data Set Ready (DDSR)	Bit 1	Bit 1	Bit 9
2	Not Connected (NC)	Parity Error (PE)	Trailing Edge Ring Indicator (TERI)	Bit 2	Bit 2	Bit 10
3	Interrupt (Int)	Framing Error (FE)	Delta Receive Line Signal Detect (DRLSD)	Bit 3	Bit 3	Bit 11
4	Loop	Break Interrupt (BI)	Clear to Send (CTS)	Bit 4	Bit 4	Bit 12
5	0	Transmitter Holding Register Empty (THRE)	Data Set Ready (DSR)	Bit 5	Bit 5	Bit 13
6	0	Transmitter Empty (TEMT)	Ring Indicator (RI)	Bit 6	Bit 6	Bit 14
7	0	Error in RCVR FIFO ① (EIRF)	Received Line Signal Detect (RLSD)	Bit 7	Bit 7	Bit 15

① This bit is 0 in Character Mode. ② See Table 3-1

TABLE 3-3. ACCESSIBLE WD76C30 SERIAL PORT REGISTERS (Cont.)



### 3.3 LINE CONTROL REGISTER

The Line Control Register provides control over the word length, number of Stop Bits, Parity, Break Control and selection of the Receiver Buffer, Transmitter Holding Register and Interrupt Enable Register.

Address A2-A0 = 3, DLAB = X - Read and Write

7	6	5	4	3	2	1	0
DLAB	SBR	STP	EPS	PEN	STB	WLS1	WLS0

<b>Signal Name</b>	<b>Default After Master Reset</b>
All signals . . . . .	0

#### Bit 7 - DLAB, Divisor Latch Access

DLAB = 0 -  
Access the Receiver Buffer, Transmitter Holding Register or Interrupt Enable Register.

DLAB = 1 -  
Access the Divisor Latches of the Baud Rate Generator during a Read or Write operation.

#### Bit 6 - SBR, Set Break Control

The SBR feature enables the CPU to alert a terminal in a computer communications system.

SBR = 0 -  
Serial Output (SOUT) follows the output of the transmitter.

SBR = 1 -  
The Serial Output (SOUT) is forced to the Spacing (logic 0) State and remains there (until reset by a low-level SBR), regardless of other transmitter activity.

#### Bit 5 - STP, Stick Parity

STP = 0 -  
When parity is enabled by PEN (bit 3), it is represented as indicated by the state of EPS (bit 4).

STP = 1 -  
When parity is enabled by PEN, the Parity bit is transmitted and then detected by the receiver in the opposite state indicated by EPS.

#### Bit 4 - EPS, Even Parity Select

EPS = 0 -  
When PEN (bit 3) equals 1 and STP equals 0, an odd number of logic 1's are transmitted or checked in the data word bits and Parity bit.

EPS = 1 -  
When PEN equals 1 and STP equals 0, an even number of bits are transmitted or checked.

#### Bit 3 - PEN, Parity Enable

PEN = 0 -  
No parity is generated or checked.

PEN = 1 -  
Parity is generated on transmitted data or checked on received data between the last data word bit and Stop bit of the serial data. The Parity bit is used to produce an even or odd number of 1's when the data word bits and the Parity bit are summed.

#### Bit 2 - STB, Number Of Stop Bits

This bit specifies the number of Stop Bits in each transmitted serial character.

STB = 0 -  
One Stop Bit is generated in the transmit data.

STB = 1 -  
When WLS1 and WLS0 (bits 1 and 0) select a 5-bit word length, 1-1/2 Stop bits are generated.

When WLS1 and WLS0 select a 6, 7 or 8-bit word length, two Stop bits are generated.

#### Bits 1, 0 - WLS1, WLS0, Word Length Select

WLS1 and WLS0 specify the number of bits in each transmitted or received serial character.

WLS1	WLS0	Word Length
0	0	5 bits
0	1	6 bits
1	0	7 bits
1	1	8 bits



### 3.4 ACE PROGRAMMABLE BAUD RATE GENERATOR

The ACE contains a programmable Baud Rate Generator with a programmable input clock of 1.843 MHz, 3.0 MHz or 8 MHz clocks, as well as a 48 MHz input for test purposes. The output frequency of the Baud Generator is 16 times the baud rate. Two 8-bit latches store the divisor in a 16-bit binary format. These Divisor Latches must be loaded during initialization in order to insure desired operation of the Baud Rate Generator. Upon loading either of the Divisor Latches, a 16-bit Baud counter is immediately loaded. This prevents long counts on initial load. Loading of either divisor Latch forces the Transmitter and Receiver into the Idle Mode. The transmitter does not enter the Idle Mode until after the character in the shift register has been transmitted.

Tables 3-3, 3-4 and 3-5 illustrate the use of the Baud Generator with three different driving frequencies. One is referenced to a 1.8432 MHz clock, another is a 3.072 MHz clock and the third is an 8.0 MHz clock.

#### NOTE

The maximum operating frequency of the Baud Rate Generator is 8.0 MHz.

The data rate should never be greater than 512 Kbaud.

DESIRED BAUD RATE	DIVISOR USED TO GENERATE 16 TIMES CLOCK	PERCENT ERROR DIFFERENCE BETWEEN DESIRED AND ACTUAL
50	2304	—
75	1536	—
110	1047	0.026
134.5	857	0.058
150	768	—
300	384	—
600	192	—
1200	96	—
1800	64	—
2000	58	0.690
2400	48	—
3600	32	—
4800	24	—
7200	16	—
9600	12	—
19200	6	—
38400	3	—
56000	2	2.860

TABLE 3-4. BAUD RATES USING 1.8432 MHz CLOCK



DESIRED BAUD RATE	DIVISOR USED TO GENERATE 16 TIMES CLOCK	PERCENT ERROR DIFFERENCE BETWEEN DESIRED AND ACTUAL
50	3840	—
75	2560	—
110	1745	0.026
134.5	1428	0.034
150	1280	—
300	640	—
600	320	—
1200	160	—
1800	107	—
2000	96	—
2400	80	—
3600	53	0.628
4800	40	—
7200	27	1.230
9600	20	—
19200	10	—
38400	5	—

TABLE 3-5. BAUD RATES USING 3.072 MHz CLOCK

DESIRED BAUD RATE	DIVISOR USED TO GENERATE 16 TIMES CLOCK	PERCENT ERROR DIFFERENCE BETWEEN DESIRED AND ACTUAL
50	10000	—
75	6667	0.005
110	4545	0.010
134.5	3717	0.013
150	3333	0.010
300	1667	0.020
600	833	0.040
1200	417	0.080
1800	277	0.080
2000	250	—
2400	208	0.160
3600	139	0.080
4800	104	0.160
7200	69	0.644
9600	52	0.160
19200	26	0.160
38400	13	0.160
56000	9	0.790
128000	4	2.344
256000	2	2.344
512000	1	2.344

TABLE 3-6. BAUD RATE USING 8.0 MHz CLOCK



### 3.5 LINE STATUS REGISTER

The Line Status Register provides status information to the CPU concerning the data transfer.

Address A2-A0 = 5, DLAB = X - Read

7	6	5	4	3	2	1	0
EIRF	TEMT	THRE	BI	FE	PE	OE	DR

Signal Name	Default After Master Reset
EIRF	0
TEMT	1
THRE	1
BI	0
FE	0
PE	0
OE	0
DR	0

#### Bit 7 - EIRF, Error in RCVR FIFO

EIRF = 0 -

When in Character Mode, EIRF is always 0.

When in FIFO Mode, a 0 indicates no error in the RCVR.

EIRF = 1 -

There is at least one parity error, framing error or break indication in the FIFO. EIRF is set to 0 when the Line Status Register is read and there are no additional errors in the FIFO.

#### Bit 6 - TEMT, Transmitter Empty

TEMT = 0 -

When in the Character Mode, at least one byte has been written into the Transmitter Holding Register.

When in the FIFO Mode, at least one byte has been written into the XMIT FIFO.

TEMT = 1 -

When in the Character Mode, the Transmitter Holding Register and Transmitter Shift Register are idle (empty).

In the FIFO Mode, the XMIT FIFO and XMIT Shift Registers are empty.

#### Bit 5 - THRE, Transmitter Holding Register Empty

##### Character Mode:

THRE indicates that the ACE is ready to accept a new character for transmission. THRE also causes the ACE to issue an interrupt to the CPU when the Transmit Holding Register Empty interrupt enable is set high.

THRE = 0 -

The CPU has loaded the Transmitter Holding Register.

THRE = 1 -

A character has been transferred from the Transmitter Holding Register into the Transmitter Shift Register.

##### FIFO Mode:

##### Normally

THRE responds immediately when the XMIT FIFO is emptied or when the first character is written into the XMIT FIFO.

The first transmitter interrupt after changing the first bit of FIFO Control Register will be immediate if the Transmit Holding Register Interrupt is enabled.

##### Exception

The Transmitter FIFO empty indications are delayed one character time, minus the last Stop Bit time, whenever the Transmitter FIFO is empty and there have not been at least two characters in Transmitter FIFO at the same time since the last time that Transmitter FIFO was empty.

THRE = 0 -

At least one character has been written into the XMIT FIFO.

THRE = 1 -

The XMIT FIFO is empty.

#### Bit 4 - BI, Break Interrupt

BI indicates that the received character is a Break.

BI = 0 -

The CPU read the contents of the Line Status Register. Restarting after a break is received requires the SIN pin to be high for at least one half bit time.





**BI = 1 -**

When in the Character Mode, the received data input has been held in the Spacing (Logic 0) state for longer than a full word transmission time (that is, the total time of Start Bit + data bits + Parity + Stop Bits).

When in FIFO Mode, BI is associated to the particular character in the FIFO, and is set when the associated character is in the top of the FIFO.

**Bit 3 - FE, Framing Error**

FE indicates that the received character did not have a valid Stop Bit.

**FE = 0 -**

The CPU read the contents of the Line Status Register.

**FE = 1 -**

In the Character Mode, the Stop Bit following the last data bit or parity bit was detected as a zero bit (Spacing Level).

In the FIFO Mode, an FE is associated with a particular character in the FIFO and is set when the associated character is at the top of the FIFO.

**Bit 2 - PE, Parity Error**

PE indicates that the received data character does not have the correct even or odd parity, as selected by the even-parity-select bit.

**PE = 0 -**

The CPU read the contents of the Line Status Register.

**PE = 1 -**

In the Character Mode, a parity error has been detected.

In the FIFO Mode, a parity error is associated with a particular character in the FIFO, and PE is set when the associated character is at the top of the FIFO.

**Bit 1 - OE, Overrun Error**

OE indicates that an Overrun Error occurred.

**OE = 0 -**

The CPU read the contents of the Line Status Register.

**OE = 1 -**

In the Character Mode, the data in the Receiver Buffer Register was not read by the CPU before the next character was transferred into the Receiver Buffer Register. This destroyed the previous character.

When in FIFO Mode, an OE occurs after the RCVR FIFO is full and the Receiver Shift Register has completely received the next character. An OE is indicated to the CPU as soon as it happens. The character in the shift register will be written over but nothing will be transferred to the FIFO.

**Bit 0 - DR, Receiver Data Ready****DR = 0 -**

In the Character Mode, the CPU read the data in the Receiver Buffer Register.

In the FIFO Mode, the receiver FIFO is empty.

**DR = 1 -**

In the Character Mode, a complete incoming character has been received and transferred into the Receiver Buffer Register.

In the FIFO Mode, a complete incoming character has been received and transferred into the RCVR FIFO.

**NOTE**

Bits 4 through 1 are the error conditions that produce a Receiver Line Status interrupt whenever any of the corresponding conditions are detected and Receiver Line Status interrupt is enabled. All bits of the Line Status Register, except bit 7, can be set or reset by writing to the register.



### 3.6 INTERRUPT IDENTIFICATION REGISTER

The ACE has an interrupt capability that allows for complete flexibility in interfacing with all popular microprocessors presently available. In order to provide minimum software overhead during data character transfers, the ACE prioritizes interrupts into four levels. Listed according to their priority the four levels of interrupt conditions are:

- Receiver Line Status
- Received Data Ready
- Transmitter Holding Register Empty
- MODEM Status

Information indicating that a prioritized interrupt is pending and source of that interrupt is stored in the Interrupt Identification Register (IIR).

The IIR, when addressed during chip-select time, freezes the highest priority interrupt pending and no other interrupts are acknowledged until the particular interrupt is serviced by the CPU. Bits 3-0 are further described in Table 3-7.

Address A2-A0 = 2, DLAB = X - Read only

7	6	5	4	3	2	1	0
FERO		0	0	IID			$\overline{IP}$

Signal Name	Default After Master Reset
FERO	00
IID	000
IP	1

#### Bits 7, 6 - FERO, FIFO Enable

The FERO bits identify whether the FIFO Control Register bit 0, has placed the device in the Character Mode or FIFO Mode.

FERO = 0 0 -  
The device is in the Character Mode

FERO = 1 1 -  
The device is in the FIFO Mode.

#### Bits 5, 4 - These bits are always logic 0.

#### Bits 3-1 - IID, Interrupt ID

The IID bits identify the highest priority interrupt pending (see Table 3-7).

#### Bit 0 - $\overline{IP}$ , Interrupt Pending

The  $\overline{IP}$  bit can be used in either a hardwired prioritized or polled environment to indicate whether an interrupt is pending.

$\overline{IP}$  = 0 -  
An interrupt is pending and the IIR contents may be used as a pointer to the appropriate interrupt service routine.

$\overline{IP}$  = 1 -  
No interrupt is pending and polling (if used) continues.



INTERRUPT IDENTIFICATION REGISTER				INTERRUPT SET AND RESET FUNCTIONS			
Bit 3	IID Bit 2	Bit 1	IP Bit 0	Priority Level	Interrupt Flag	Interrupt Source	Interrupt Reset Control
0	0	0	1	—	None	None	—
0	1	1	0	Highest	Receiver Line Status	Overrun Error or Parity Error or Framing Error or Break Interrupt	Reading the Line Status Register
0	1	0	0	Second	Received Data Available	Receiver Data Available	Reading the Receiver Buffer Register or FIFO dropping below the trigger level
1	1	0	0	Second	Character Timeout Identification	No Characters have been input or removed from RCVR FIFO during the last 4 character times, and at least one character occupies it during this time.	Reading the Receiver Buffer Register
0	0	1	0	Third	Transmitter Holding Register Empty	Transmitter Holding Register Empty	Reading the IIR Register (if source of interrupt) or Writing into the Transmitter Holding Register
0	0	0	0	Fourth	MODEM Status	Clear to Send or Data Set or Ring Indicator or Received Line Signal Detect	Reading the MODEM Status Register

TABLE 3-7. INTERRUPT CONTROL FUNCTIONS



**3.7 INTERRUPT ENABLE REGISTER**

When INT (bit 3 of Modem Control Register) is a logic 1, the Interrupt Enable Register controls the selection of the four interrupt sources of the ACE, making it possible to separately activate the device's internal interrupt signals.

It is possible to disable the entire interrupt system, or selected interrupts by configuring bits three through zero of the Interrupt Enable Register.

Disabling the interrupt system inhibits the Interrupt Identification Register and the active internal interrupt signal. All other system functions operate in their normal manner, including the setting of the Line Status and MODEM Status Registers.

Address A2-A0 = 1, DLAB = 0 - Read and Write

7	6	5	4	3	2	1	0
0	0	0	0	EDSSI	ERLSI	ETBEI	ERBFI

Signal Name	Default After Master Reset
All signals	0

**Bits 7-4** - These four bits are always set to 0 by the hardware.

- Bit 3 - EDSSI**, Enable MODEM Status Interrupt  
 EDSSI = 0 - Disables the MODEM Status Interrupt.  
 EDSSI = 1 - Enables the MODEM Status Interrupt.

- Bit 2 - ERLSI**, Enable Receiver Line Status Interrupt  
 ERLSI = 0 - Disables the Receiver Line Status Interrupt.  
 ERLSI = 1 - Enables the Receiver Line Status Interrupt.

- Bit 1 - ETBEI**, Enable Transmitter Holding Register Empty Interrupt  
 ETBEI = 0 - Disables the Transmitter Holding Register Empty Interrupt.  
 ETBEI = 1 - Enables the Transmitter Holding Register Empty Interrupt.

- Bit 0 - ERBFI**, Enable Received Data Available Interrupt  
 ERBFI = 0 - Disables the Received Data Available Interrupt.  
 ERBFI = 1 - Enables the Received Data Available Interrupt.

**3.8 SCRATCH PAD REGISTER**

This 8-bit register does not control or report status on any part of the ACE. It can be used by the programmer as a general purpose register.

Address A2-A0 = 7, DLAB = X - Read and Write

7	6	5	4	3	2	1	0

Signal Name	Default After Master Reset
All signals	None



### 3.9 FIFO CONTROL REGISTER

The FIFO Control Register is used to enable the FIFO Mode, clear FIFOs, set the RCVR FIFO trigger levels and select the mode of DMA signaling.

Address A2-A0 = 2, DLAB = X, Write only

7	6	5	4	3	2	1	0
RFTL		Reserved		Not Used	TFR	RFR	FEWO

Signal Name	Default After Master Reset
All signals	0

#### Bits 7, 6 - RFTL, RCVR FIFO Trigger Level

RFTL controls the trigger level of the Received Data Available Interrupt.

RFTL			
7	6	Trigger Level (bytes)	
0	0	- 01	
0	1	- 04	
1	0	- 08	
1	1	- 14	

**Bits 5, 4** - Reserved for future use and should be programmed to zeros.

**Bit 3** - Not Used

In the WD16C550 this is the DMS bit.

**Bit 2 - TFR, Transmitter FIFO Reset**

Writing a one to TFR clears all characters from the XMIT Error FIFO and resets its counters and this bit to 0. The shift register and XMIT FIFO are not cleared.

**Bit 1 - RFR, Receiver FIFO Reset**

Writing a one to RFR clears all characters from the RCVR Error FIFO and resets its counters and this bit to 0. The shift register and RCVR FIFO are not cleared.

**Bit 0 - FEWO, FIFO Enable**

FEWO = 0 -  
XMIT and RCVR FIFOs are disabled

FEWO = 1 -  
XMIT and RCVR FIFOs are enabled. When changing from Character Mode to FIFO Mode, data in the FIFOs does not automatically clear. Setting or resetting

FEWO clears all characters from the RCVR Error FIFO and resets the XMIT and RCVR FIFO counters to 0. FEWO must be set to 1 before setting TFR and RFR or they will not be programmed. As illustrated by the following boolean equation, FEWO along with SP\_FIFO in the Mode Selection Register determine whether the Character Mode or FIFO Mode is selected.

$$\text{Character Mode} = \overline{\text{FEWO}} + \overline{\text{SP\_FIFO}}$$

$$\text{FIFO Mode} = \text{FEWO} \bullet \text{SP\_FIFO}$$

### 3.10 MODEM CONTROL REGISTER

The MODEM Control Register controls the interface with the MODEM, data set or a peripheral device emulating a MODEM.

Address A2-A0 = 4, DLAB = X - Read and Write

7	6	5	4	3	2	1	0
0	0	0	LOOP	INT	NC	RTS	DTR

Signal Name	Default After Master Reset
All signals	0

**Bits 7-5** - These three bits are always set to 0 by the hardware.

**Bit 4 - LOOP, Loopback Mode**

This bit provides a loopback feature for diagnostic testing of the ACE. Selecting the Loopback Mode results in the following setup (Refer to Figure 3-1):

- The transmitter Serial Output (SOUT) is set to a logic 1 (high) state.
- The receiver Serial Input (SIN) is disconnected.
- The output of the Transmitter Shift Register is "looped back" into the Receiver Shift Register input.

8



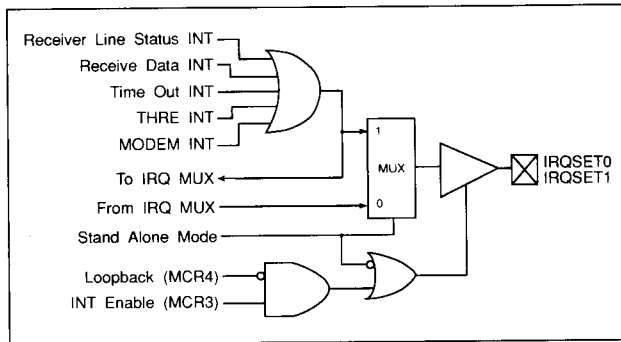

**FIGURE 3-1. INTERRUPT SIGNAL LOGIC**

- The four MODEM Control Inputs ( $\overline{\text{CTS}}$ ,  $\overline{\text{DSR}}$ ,  $\overline{\text{RLSD}}$  and  $\overline{\text{RI}}$ ) are disconnected, and the MODEM Control Register bits 3-0 are internally connected to the four MODEM Control inputs.

While in the Stand Alone and Loopback Mode, the IRQSET outputs are tri-stated (see Figure 3-1). In the Loopback Mode, data that is transmitted is immediately received. This feature allows the processor to verify the transmit and receive data paths of the ACE.

In the Loopback Mode, the receiver and transmitter interrupts are fully operational. The MODEM Control Interrupts are also operational but the interrupts' sources are now the lower four bits of the MODEM Control Register instead of the four MODEM Control inputs. The interrupts are still controlled by the Interrupt Enable Register.

The ACE MODEM interrupt system can be tested by writing into the lower four bits of the MODEM Status Register.

To return to normal operation, the registers must be reprogrammed for normal operation and then LOOP (bit 4) reset to a logic 0.

LOOP = 0 -  
Normal Mode.

LOOP = 1 -  
Loopback Mode.

### Bit 3 - INT, Interrupt

INT enables the IRQSET output when in the Stand Alone Mode. In Loopback Mode this bit is connected internally to bit 7 of the MODEM Status Register (Refer to Figure 3-1).

INT = 0 -

The IRQSET output is tristated.

INT = 1 -

The IRQSET output is enabled in the Stand Alone Mode.

### Bit 2 - NC, No external connection.

In the Loopback Mode, this bit is connected internally to bit 6 of the MODEM Status Register.

### Bit 1 - RTS, Request To Send

Bit 1 controls the  $\overline{\text{RTS}}$  signal. In the Loopback Mode, this bit is connected internally to bit 4 of the MODEM Status Register.

RTS = 0 -

$\overline{\text{RTS}}$  is set to a logic one.

RTS = 1 -

$\overline{\text{RTS}}$  is set to a logic zero.

### Bit 0 - DTR, Data Terminal Ready

Bit 0 controls the  $\overline{\text{DTR}}$  signal. In the Loopback Mode, this bit is connected internally to bit 5 of the MODEM Status Register.

DTR = 0 -

$\overline{\text{DTR}}$  is set to a logic one.

DTR = 1 -

$\overline{\text{DTR}}$  is set to a logic zero.

### NOTE

The  $\overline{\text{DTR}}$  output of the ACE may be applied to an EIA inverting line driver (such as the DS1488) to obtain the proper polarity input at the succeeding MODEM or data set.



### 3.11 MODEM STATUS REGISTER

The MODEM Status Register provides the current state of the control lines from the MODEM (or peripheral device) to the CPU. In addition to this current-state information, bits 3 through 0 of the MODEM Status Register provide change information. These bits are set to a logic 1 whenever a control input from the MODEM changes state. They are reset to logic 0 whenever the CPU reads the MODEM Status Register.

Address A2-A0 = 6, DLAB = X - Read and Write

7	6	5	4	3	2	1	0
RLSD	RI	DSR	CTS	DRLSD	TERI	DDSR	DCTS

Signal Name	Default After Master Reset
RLSD	X
RI	X
DSR	X
CTS	X
DRLSD	0
TERI	0
DDSR	0
DCTS	0

#### Bit 7 - RLSD, Received Line Signal Detect

RLSD is the complement of the Received Line Signal Detect (RLSD) input.

In the Loopback Mode (bit 4 of the MODEM Control Register set to 1) this bit is connected internally to bit 3 of the MODEM Control Register (INT).

#### Bit 6 - RI, Ring Indicator

RI is the complement of the Ring Indicator (RI) input. In the Loopback Mode (bit 4 of the MODEM Control Register set to 1) this bit is connected internally to bit 2 of the MODEM Control Register.

#### Bit 5 - DSR, Data Set Ready

DSR is the complement of the Data Set Ready (DSR) input. In the Loopback Mode (bit 4 of the MODEM Control Register set to 1) this bit is connected internally to bit 0 of the MODEM Control Register (DTR).

#### Bit 4 - CTS, Clear To Send

CTS is the complement of the Clear to Send (CTS) input. In the Loopback Mode (bit 4 of the MODEM Control Register set to 1) this bit is connected internally to bit 1 of the MODEM Control Register (RTS).

#### Bit 3 - DRLSD, Delta Received Line Signal Detector

DRLSD is the Delta Received Line Signal Detector (DRLSD) indicator.

DRLSD = 0 -

The RLSD input to the WD76C30 has not changed state since the last time it was read by the CPU.

DRLSD = 1 -

The RLSD input to the WD76C30 has changed state since the last time it was read by the CPU.

#### Bit 2 - TERI, Trailing Edge of Ring Indicator

TERI is the Trailing Edge of Ring Indicator (TERI) detector.

TERI = 0 -

The RI input to the WD76C30 has not changed from an On (logic 1) to an Off (logic 0) condition.

TERI = 1 -

The RI input to the WD76C30 has changed from an On (logic 1) to an Off (logic 0) condition.

#### Bit 1 - DDSR, Delta Data Set Ready

DDSR is the Delta Data Set Ready (DDSR) indicator.

DDSR = 0 -

The DSR input to the WD76C30 has not changed state since the last time it was read by the CPU.

DDSR = 1 -

The DSR input to the WD76C30 has changed state since the last time it was read by the CPU.

#### Bit 0 - DCTS, Delta Clear to Send

DCTS is the Delta Clear to Send (DCTS) indicator.



DCTS = 0 -

The CTS input to the WD76C30 has not changed state since the last time it was read by the CPU.

DCTS = 1 -

The CTS input to the WD76C30 has changed state since the last time it was read by the CPU.

#### NOTE

Setting bits 3, 2, 1, or 0 to a logic 1 generates a MODEM Status Interrupt.

## 3.12 FIFO OPERATION NOTES

### 3.12.1 FIFO Interrupt Mode Operation

When FEWO and ERBFI are 1 (bit 0 of the FIFO Control Register and bit 1 of the Interrupt Enable Register), the following RCVR interrupts will occur.

1. A FIFO timeout interrupt occurs when the following is true:
  - a. There is at least one byte in the RCVR FIFO.
  - b. No character has been received in four continuous character times (if two stop bits are being used, the second one is included in this time delay).
  - c. The most recent CPU read from the FIFO has exceeded four continuous character times.

The timeout counter is proportional to the baud rate. After a timeout interrupt, the interrupt is cleared and the timer is reset when the CPU reads a character from the RCVR FIFO.

2. When the RCVR FIFO reaches its programmed trigger level, the receive data interrupt is set. This interrupt is cleared as soon as the FIFO level falls below the trigger level.
3. When the XMIT FIFO is empty, the THRE interrupt is set and is reset when one character is written to the XMIT FIFO.

### 3.12.2 FIFO Polling Mode Operation

The FIFO Polling Mode is initialized when FEWO is 1 and EDSSI, ERLSI, ETBEI and ERBFI are 0 (bit 1 of the FIFO Control Register and bits 3 through 0 of the Interrupt Enable Register). In polling mode, the user can poll the LSR directly to check the transmitter and receiver status. Since the receiver and transmitter are controlled separately, either one or both can be in polling mode.

There is no trigger level reached or timeout condition indicated on the interrupt pin in the FIFO Polling Mode. However, the RCVR and XMIT FIFOs are still fully capable of holding characters.

### 3.12.3 FIFO Pointer

The RCVR FIFO has an internal pointer that automatically points to the RCVR Data byte and associated Status byte to be read. Reading the RCVR Data byte increments the internal counter, while reading the Status byte does not, therefore, the Status byte should always be read prior to reading the Data byte associated with it.





### 4.0 PARALLEL PORT DESCRIPTION

The parallel port supports Centronics type printers. When  $\overline{CS2}$  is asserted, the parallel port is selected, allowing access to all parallel port control and status registers. (Refer to Tables 4-1 and 4-2.)

A2	A1	A0	$\overline{IOR}$	$\overline{IOW}$	REGISTER
X	0	0	1	0	Data - Write
X	0	0	0	1	Data - Read
X	0	1	0	1	Status - Read
X	1	0	1	0	Control - Write
X	1	0	0	1	Control - Read
0	1	1	1	0	Address Select Register - Write
0	1	1	0	1	Address Select Register - Read
1	1	1	1	0	Data Access Register - Write ①
1	1	1	0	1	Data Access Register - Read ①
X	0	1	1	0	Invalid

① A2-A0,  $\overline{IOR}$  and  $\overline{IOW}$ , in conjunction with bits 2-0 of the Address Selection Register, select one of six registers. See section 5.1.

TABLE 4-1. PARALLEL PORT ( $\overline{CS2} = 0$ ) REGISTER ADDRESS

BIT NO.	READ DATA 0	WRITE DATA 0	READ STATUS 1	READ CONTROL 2	WRITE CONTROL 2
0	Data Bit 0	Data Bit 0	1	STB	STB
1	Data Bit 1	Data Bit 1	1	AFD	AFD
2	Data Bit 2	Data Bit 2	$\overline{INT}$ ①	$\overline{INIT}$	$\overline{INIT}$
3	Data Bit 3	Data Bit 3	$\overline{ERROR}$	SLIN	SLIN
4	Data Bit 4	Data Bit 4	SLCT	IRQ ENB	IRQ ENB
5	Data Bit 5	Data Bit 5	PE	1	DIR ②
6	Data Bit 6	Data Bit 6	$\overline{ACK}$	1	NC
7	Data Bit 7	Data Bit 7	$\overline{BUSY}$	1	NC

① This bit is only available when the parallel port interrupt is PS/2 compatible (Mode Selection Register bit 2 is a 1), Otherwise the bit is always a 1.

② This bit is only available when the parallel port bus is PS/2 compatible (Mode Selection Register bit 1 is a 1).

TABLE 4-2. ACCESSIBLE PARALLEL PORT REGISTERS



**4.1 DATA REGISTER**

This read/write register is used to write to or read data from the Parallel Port Data Bus.

Register select - Write:

CS2 asserted - IOR de-asserted - IOW asserted  
Address A2 = X, A1-A0 = 0

Register select - Read:

CS2 asserted - IOR asserted - IOW de-asserted  
Address A2 = X, A1-A0 = 0

7	6	5	4	3	2	1	0
Parallel Bus Data							

Signal Name	Default After Master Reset
All signals . . . . .	0

**Bits 7-0**

These bits represent the data being written to or read from the Parallel Port Data Bus.

**4.2 STATUS REGISTER - READ**

The contents of this read only register represents the status of the corresponding Parallel Port pins (refer to Tables 2-1, 4-2 and Figure 2-1).

Register select:

CS2 asserted - IOR asserted - IOW de-asserted  
Address A2 = X, A1-A0 = 1

7	6	5	4	3	2	1	0
BUSY	ACK	PE	SLCT	ERROR	INT	1	1

Signal Name	Default After Master Reset
BUSY . . . . .	X
ACK . . . . .	X
PE . . . . .	X
SLCT . . . . .	X
ERROR . . . . .	X
INT . . . . .	0
Bits 1, 0 . . . . .	1

**Bit 7 - BUSY**

**Bit 6 - ACK, Acknowledge**

**Bit 5 - PE, Parity Error**

**Bit 4 - SLCT, Select**

**Bit 3 - ERROR**

**Bit 2 - INT, Interrupt**

INT represents the status of the Parallel Port's internal interrupt signal. This bit is only available when the parallel port interrupt is PS/2 compatible (Mode Selection Register bit 2 equals 1) otherwise it is a 1.

**Bits 1, 0**

These bits are set to one by the hardware.



**4.3 CONTROL REGISTER - WRITE**

The Control Register is used to write to the associated lines and, with the exception of bits 7 through 5, may be read by a Control Register - Read operation. See section 4.4.

Register select:  
 CS2 asserted - IOR de-asserted - IOW asserted  
 Address A2 = X, A1-A0 = 2

7	6	5	4	3	2	1	0
NC	NC	DIR	IRQ_ENB	SLIN	INIT	AFD	STB

Signal Name	Default After Master Reset
Bits 7, 6	X
DIR	0
IRQ_ENB	0
SLIN	0
INIT	0
AFD	0
STB	0

Bits 7, 6 - Not connected

**Bit 5 - DIR**, Direction

DIR works in conjunction with the BIDEN pin to determine the direction of the parallel port data bus (refer to Table 4-3). DIR only functions when the parallel port bus is PS/2 compatible as indicated by the Mode Selection Register bit 1 = 1.

Port Mode	Biden Pin 76	Direction Bit - 5	Port Direction	Compatibility
Extended	1	0	Write *	PS/2
Extended	0	X	Write *	PS/2
Extended	1	1	Read *	PS/2
Compatible	1	N/A	Read *	PC/AT
Compatible	0	N/A	Write *	PC/AT

\* Read and write refer to internal WD76C30 reading and writing the Parallel Port.

**TABLE 4-3. PARALLEL PORT OPERATION MODES**

**Bit 4 - IRQ\_ENB**, Interrupt Enable

IRQ\_ENB = 0 -  
 Parallel Port Interrupt is not enabled.

IRQ\_ENB = 1 -  
 Parallel Port Interrupt is enabled.

**Bit 3 - SLIN**, Line Printer Select

**Bit 2 - INIT**, Line Printer Initialize

**Bit 1 - AFD**, Line Printer Autofeed

**Bit 0 - STB**, Line Printer Strobe

**4.4 CONTROL REGISTER - READ**

Bits 4 through 0 are read/write bits and represent the state as set by a Control Register - Write operation. Bit 5 (DIR) is a write only bit, and, along with bits 7 and 6, are always represented with a 1. See section 4.3

Register select:  
 CS2 asserted - IOR asserted - IOW de-asserted  
 Address A2 = X, A1-A0 = 2

7	6	5	4	3	2	1	0
1	1	1	IRQ_ENB	SLIN	INIT	AFD	STB

Signal Name	Default After Master Reset
Bits 7-5	1
IRQ_ENB	0
SLIN	0
INIT	0
AFD	0
STB	0

**Bits 7-5**

These bits are set to one by the hardware.

**Bit 4 - IRQ\_ENB**, Interrupt Enable

IRQ\_ENB = 0 -  
 Parallel Port Interrupt is not enabled.

IRQ\_ENB = 1 -  
 Parallel Port Interrupt is enabled.

**Bit 3 - SLIN**, Line Printer Select

**Bit 2 - INIT**, Line Printer Initialize

**Bit 1 - AFD**, Line Printer Autofeed

**Bit 0 - STB**, Line Printer Strobe



## 5.0 INTERRUPT, CLOCK AND MODE SELECTION REGISTERS

The internal registers used for the interrupt multiplexing, clock selection and mode selection are accessed in a two step process, using two address locations in the Parallel Port Register. First, the address for the desired register to be accessed is written into the Address Select Register located at address three of the Parallel Port. Then the data to be read from or written to the selected register is accessed through the Data Access Register (see Table 4-1), located at address seven in the Parallel Port. It is not necessary for these write operations to follow each other.

### 5.1 ADDRESS SELECTION REGISTER

Register select - Read:  
 CS2 asserted - IOR asserted - IOW de-asserted  
 Address A2-A0 = 3

Register select - Write:  
 CS2 asserted - IOR de-asserted - IOW asserted  
 Address A2-A0 = 3

7	6	5	4	3	2	1	0
TEST BIT	SER_PRT_1 CLK	SER_PRT_0 CLK	DAT_ACC_REG				

<b>Signal Name</b>	<b>Default After Master Reset</b>
All signals . . . . .	0

#### Bit 7 - Testbit

The Testbit replaces the Serial 1, Serial 0 and Parallel Port interrupt signals to the internal interrupt multiplexer with the SLCT, BUSY and PE signals, respectively.

#### Bits 6, 5 - SER\_PRT\_1 CLK, Serial Port 1 Clock

These bits select the input clock used by serial port 1.

SER\_PRT\_1 CLK

6	5	Serial Port 1 Clock
0	0	1.8432 MHz
0	1	3.072 MHz
1	0	MSTRX1
1	1	8.0 MHz

#### Bits 4, 3 - SER\_PRT\_0 CLK, Serial Port 0 Clock

These bits select the input clock used for serial port 0.

SER\_PRT\_0 CLK

4	3	Serial Port 0 Clock
0	0	1.8432 MHz
0	1	3.072 MHz
1	0	MSTRX1
1	1	8.0 MHz

#### Bits 2-0 - DAT\_ACC\_REG, Data access register name

These bits, in conjunction with address A2-A0 = 7, select one of the six registers listed below. See Table 4-1.

When all accesses are completed, this field should be set to the Parking Value (7). This prevents inadvertent accesses to the Data Access Register from disturbing the setup during normal operation.

DAT\_ACC\_REG

2	1	0	Data Access Register Name	Reset Mode
0	0	0	Clock Select Reg.	00H
0	0	1	Clock Disable Reg.	00H
0	1	0	Serial Port 0 Int. Selection Reg.	00H
0	1	1	Serial Port 1 Int. Selection Reg.	00H
1	0	0	Parallel Port Int. Selection Reg.	00H
1	0	1	Mode Selection Reg.	00H
1	1	0	Version Register	
1	1	1	Parking Value	



B2 B1 B0	CLK287 FREQUENCY	COPROCESSOR SUPPORTED
0 0 0	8 MHz, 33% Duty Cycle	8 MHz Intel 80287 8 MHz AMD 80C287
0 0 1	9.6 MHz, 33% Duty Cycle	10 MHz Intel 80287 10 MHz AMD 80C287 10 MHz AMD 80EC287
0 1 0	12 MHz, 33% Duty Cycle	10 MHz AMD 80EC287 12 MHz AMD 80C287 12 MHz AMD 80EC287
0 1 1	12 MHz, 50% Duty Cycle	12 MHz Intel 80C287A
1 0 0	16 MHz, 33% Duty Cycle	16 MHz AMD 80C287 16 MHz AMD 80EC287
1 0 1	16 MHz, 50% Duty Cycle	Future Expansion
1 1 0	Logic Low	CLK287 Stopped low
1 1 1	Logic High	CLK287 Stopped high

TABLE 5-1. CLOCK SELECTION REGISTER

5.2 CLOCK SELECTION REGISTER

The Clock Selection Register is addressed by the Address Selection Register bits 2-0 = 0 and address bits A2-A0 = 7. See Table 4-1 and section 5.1.

7	6	5	4	3	2	1	0
RESERVED				CLOCK CO-CPU			

<b>Signal Name</b>	<b>Default After Master Reset</b>
All signals . . . . .	0

Bits 7-3 - Reserved for future use and should be programmed to 0.

Bits 2-0 - CLOCK CO-CPU

These bits are used to select the desired frequency and duty cycle for supporting the 80287 coprocessor. Refer to Table 5-1 for the bit configurations.

5.3 SLEEP MODE

For low power consumption, the internal oscillators may be individually disabled via the Clock Disable Register described in section 5.4. For minimum power consumption, a sleep mode is offered which disables the 48 MHz clock, KBCLK, CLK287, ATCLK, Parallel Port (PD0 - 7), Data Bus (D0-7), all outputs, all pullups and, except for CS0, CS1, CS2 and RESET, all inputs. Although KBCLK, CLK287, and ATCLK are disabled during sleep mode, their outputs are held low with small pulldown transistors.

Sleep Mode is activated by hardware asserting all three Chip Selects (CS0, CS1 and CS2) simultaneously. All registers are preserved in the sleep mode. Sleep Mode is deactivated when one or more of the Select signals are de-asserted.





### 5.5 MODE SELECTION REGISTER

The Mode Selection Register is addressed by the Address Selection Register bits 2-0 = 5 and address bits A2-A0 = 7. See Table 4-1 and section 5.1.

7	6	5	4	3	2	1	0
				PUD	ATPS2 INT	ATPS2 PP	SP FIFO

**Signal Name** . . . . . **Default After Master Reset**  
 All signals . . . . . 0

**Bits 7-4** - Reserved and should be programmed to 0.

#### Bit 3 - PUD, Power-up Power-down

PUD must always be high when powering down the ports by turning off V<sub>DD</sub>.

**PUD = 0** -  
 The serial and parallel ports are in the power-up mode.

**PUD = 1** -  
 The serial and parallel ports are in the power-down mode (see Tables 3-2 and 6-11).

With the exception of addresses 011 and 111 of the parallel port, all registers are reset. Also, the following signals are disabled: DTR0, DTR1, RST0, RST1, SOUT0, SOUT1, PD0-7, BIDEN, ERROR, SLCT, PE, ACK, BUSY, INIT, SLIN, STB AND AFD.

#### Bit 2 - ATPS2\_INT, PC/AT PS/2 Parallel Port Interrupt

**ATPS2\_INT = 0** -  
 The Parallel Port Interrupt signal is PC/AT compatible.

**ATPS2\_INT = 1** -  
 The Parallel Port interrupt signal is PS/2 compatible.

#### Bit 1 - ATPS2\_PP, PC/AT PS/2 Parallel Port

**ATPS2\_PP = 0** -  
 The Parallel Port Bus is configured as a PC/AT compatible Parallel Port.

**ATPS2\_PP = 1** -  
 The Parallel Port Bus is configured as a PS/2 extended Parallel Port.

#### Bit 0 - SP\_FIFO, Serial Port FIFO

**SP\_FIFO = 0** -  
 Both Serial Ports are configured to operate in non-FIFO mode (Character Mode).

**SP\_FIFO = 1** -  
 Both Serial Ports can operate in the FIFO mode if the applicable FEWO is set to 1. The FEWO bit is located in the FIFO Control Register described in section 3.9. The following boolean equation illustrates how to select the Character Mode or FIFO Mode.

$$\begin{aligned} \text{Character Mode} &= \overline{\text{FEWO}} + \overline{\text{SP\_FIFO}} \\ \text{FIFO Mode} &= \text{FEWO} \bullet \text{SP\_FIFO} \end{aligned}$$

### 5.6 INTERRUPT MULTIPLEXER

The WD76C30 provides the logic required to interface the PC/AT interrupt request lines with the WD7XC10 Single Chip AT Controller. The WD7XC10 generates input signals MXCTL2 - 0 and the WD76C30 uses these signals to select the IRQ inputs. Table 5-3 identifies the multiplexing sequence for the IRQSET0 and IRQSET1 signals. The output of the sampled IRQ inputs are provided on the IRQSET0 and IRQSET1 outputs (see Figure 5-2 IRQSET).

Negative pulse extension logic widens negative pulses on twelve of the sixteen MUX inputs. They are IRQ3-7, IRQ9-12, IRQ14,15 and KBINT. Positive pulse extension logic widens a positive pulse on IRQ8. The pulse width is extended by five positive going edges on MXCTL0 from the leading edge of the pulse or three positive going edges on MXCTL0 from the trailing edge of the pulse, whichever lasts longer. Note that pulses in the opposite direction that don't include three rising MXCTL0 edges are never seen on IRQSET0 or IRQSET1. None of this pulse extension logic applies to RESCPU, ROM8 or A20GT (see Figure 5-1 Interrupt Mux Block Diagram).



When the appropriate bits in the Serial Port 0 Interrupt Selection Register (see section 5.7) are set to the Stand Alone Mode, the interrupt multiplexing logic is disabled. IRQSET0 and IRQSET1 are defined in Table 5-2. The Serial Port 0 Interrupt Selection Register and Serial Port 1 Interrupt Selection Register are used to assign Serial Port Interrupts to IRQ MUX inputs. The Parallel Port Interrupt Selection Register is used to assign the Parallel Port Interrupt to one IRQ MUX input.

IRQSET0 = Serial Port 0 Interrupt (tri-state enabled by bit 3 of the Modem Control Register)
IRQSET1 = Serial Port 1 Interrupt (tri-state enabled by bit 3 of the Modem Control Register)
IRQ7 = Parallel Port Interrupt (tri-state enabled by bit 4 of the parallel port Write Control Register)

TABLE 5-2. STAND ALONE MODE

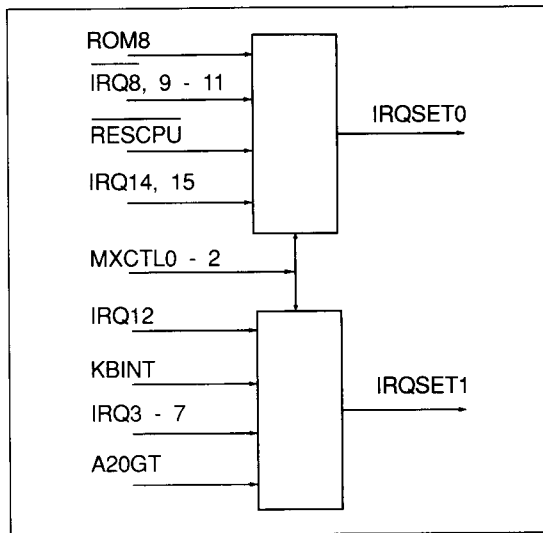

FIGURE 5-2. IRQSET - WHEN NOT IN STAND ALONE MODE

MXCTL			IRQSET0
2	1	0	
0	0	0	IRQ8
0	0	1	IRQ9
0	1	0	IRQ10
0	1	1	IRQ11
1	0	0	ROM8
1	0	1	RESCPU
1	1	0	IRQ14
1	1	1	IRQ15
MXCTL			IRQSET1
2	1	0	
0	0	0	IRQ12
0	0	1	KBINT
0	1	0	A20GT
0	1	1	IRQ3
1	0	0	IRQ4
1	0	1	IRQ5
1	1	0	IRQ6
1	1	1	IRQ7

TABLE 5-3. MXCTL2 - 0  
IRQSET0 - 1 MULTIPLEXING





**5.7 SERIAL PORT 0 INTERRUPT SELECTION REGISTER**

The Serial Port 0 Interrupt Selection Register is addressed by the Address Selection Register bits 2-0 = 2 and address bits A2-A0 = 7. See Table 4-1 and section 5.1.

7	6	5	4	3	2	1	0
SP0_INT_SEL							

<b>Signal Name</b>	<b>Default After Master Reset</b>
All signals . . . . .	0

**Bits 7-4** - Reserved and should be programmed to 0.

**Bits 3-0 - SP0\_INT\_SEL**, Serial Port 0 Interrupt Select

These bits determine which IRQ MUX input is to be replaced by the internal Serial Port 0 Interrupt. The Stand Alone Mode may also be selected by these bits and applies to all ports.

Bits 4 and 3 of the Modem Control Register (refer to section 3.10) must be set as follows:

$$EN = (MCR \text{ bit } 4 = 0 \bullet \text{ bit } 3 = 1)$$

EN	B3	B2	B1	B0	Serial Port 0 Interrupt Selection
X	0	0	0	0	Disabled
1	0	0	0	1	IRQ3
1	0	0	1	0	IRQ4
1	0	0	1	1	IRQ5
1	0	1	0	0	IRQ6
1	0	1	0	1	IRQ7
1	0	1	1	0	IRQ10
1	0	1	1	1	IRQ11
1	1	0	0	0	ROM8
1	1	0	0	1	IRQ15
X	1	1	1	1	Stand Alone Mode

All other combinations are reserved.

**5.8 SERIAL PORT 1 INTERRUPT SELECTION REGISTER**

The Serial Port 1 Interrupt Selection Register is addressed by the Address Selection Register bits 2-0 = 3 and address bits A2-A0 = 7. See Table 4-1 and section 5.1.

7	6	5	4	3	2	1	0
SP1_INT_SEL							

<b>Signal Name</b>	<b>Default After Master Reset</b>
All signals . . . . .	0

**Bits 7-4** - Reserved and should be programmed to 0.

**Bits 3-0 - SP1\_INT\_SEL**, Serial Port 1 Interrupt Select

These bits determine which IRQ MUX input is to be replaced by the internal Serial Port 1 Interrupt.

Bits 4 and 3 of the Modem Control Register (refer to section 3.10) must be set as follows:

$$EN = (MCR \text{ bit } 4 = 0 \bullet \text{ bit } 3 = 1)$$

EN	B3	B2	B1	B0	Serial Port 1 Interrupt Selection
X	0	0	0	0	Disabled
1	0	0	0	1	IRQ3
1	0	0	1	0	IRQ4
1	0	0	1	1	IRQ5
1	0	1	0	0	IRQ6
1	0	1	0	1	IRQ7
1	0	1	1	0	IRQ10
1	0	1	1	1	IRQ11
1	1	0	0	0	ROM8
1	1	0	0	1	IRQ15

All other combinations are reserved.

**NOTE**

The Serial Port 1 Interrupt Selection Register has priority over the Serial Port 0 Interrupt Selection Register. That is, Serial Port 1 interrupt replaces the Serial Port 0 interrupt when both registers select the same interrupt. The interrupts are not ORed.



**5.9 PARALLEL PORT INTERRUPT SELECTION REGISTER**

The Parallel Port Interrupt Selection Register is addressed by the Address Selection Register bits 2-0 = 4 and address bits A2-A0 = 7. See Table 4-1 and section 5.1.

7	6	5	4	3	2	1	0
				PP_INT_SEL			

**Signal Name** **Default After Master Reset**  
 All signals . . . . . 0

**Bits 7-4** - Reserved and should be programmed to 0.

**Bits 3-0 - PP\_INT\_SEL**, Parallel Port Interrupt Select

These bits determine which IRQ MUX input is to be replaced by the internal Parallel Port Interrupt.

IRQ\_ENB is bit 4 of the Parallel Port Control Register (refer to section 4.3) and must be set to 1.

IRQ EN	B3	B2	B1	B0	Parallel Port Interrupt Selection
X	0	0	0	0	Disabled
1	0	0	0	1	IRQ3
1	0	0	1	0	IRQ4
1	0	0	1	1	IRQ5
1	0	1	0	0	IRQ6
1	0	1	0	1	IRQ7
1	0	1	1	0	IRQ10
1	0	1	1	1	IRQ11
1	1	0	0	0	ROM8
1	1	0	0	1	IRQ15

All other combinations are reserved.

**NOTE**

The Parallel Port Interrupt Selection Register has priority over both of the Serial Port Interrupt Selection Registers. That is, the Parallel Port interrupt replaces the Serial Port 0 or 1 interrupt when the registers select the same interrupt. The interrupts are not ORed.

**5.10 VERSION REGISTER**

The Version Register is a read only register and contains the ones-compliment of the version of the WD76C30. FF hex represents Revision A, B and C. FE hex is revision D.

The Version Register is addressed by the Address Selection Register bits 2-0 = 6 and address bits A2-A0 = 7. See Table 4-1 and section 5.1.

7	6	5	4	3	2	1	0
Version Number							

**Signal Name** **Default After Master Reset**  
 All signals . . . . . X



## 6.0 ELECTRICAL SPECIFICATIONS

### 6.1 MAXIMUM RATINGS

Temperature Under Bias	.....0°C (32°F) to 70°C (158°F)
Storage Temperature	.....-65°C (-85°F) to +150°C (302°F)
All Input or Output Voltages with respect to Vss	.....-0.5V to +7.0V
Power Dissipation	.....300 mW

#### NOTE

Maximum limits indicate where permanent device damage occurs. Continuous operation at these limits is not intended and should be limited to those conditions specified under DC Operating Characteristics.

### 6.2 CAPACITANCE

Ta = 25°C (77°F), f = 1.0 MHz, VccA = 5.0V, VccB = 5.0V, Vss = 0V

SYMBOL	CHARACTERISTIC	TYP.	MAX.	UNITS	TEST CONDITIONS
Cxin	Clock Input Capacitance	15	20	pF	fc = 1 MHz
Cxout	Clock Output Capacitance	20	30	pF	
Cin	Input Capacitance	6	10	pF	Unmeasured Pins Returned to Vss
Cout	Output Capacitance	10	20	pF	Unmeasured Pins Returned to Vss

TABLE 6-1 CAPACITANCE

## 6.3 DC OPERATING CHARACTERISTICS

Ta = 0°C (32°F) to =70°C (158°F), VDD = +5V ±5%, VDD2 = +5V ±5%  
 Vss = 0V, unless otherwise specified.

SYMBOL	CHARACTERISTIC	MIN	MAX	UNITS	TEST CONDITIONS
Vilx	Clock Input Low Voltage	-0.5	0.8	V	
Vihx	Clock Input High Voltage	2.0	Vcc	V	
Vil	Input Low Voltage	-0.5	0.8	V	
Vih	Input High Voltage	2.0	Vcc	V	Except MXCTL2-0
		2.3	Vcc	V	MXCTL2-0
Vol	Output Low Voltage		0.4	V	Iol = 4.0 mA on DB0-DB7. Iol = 24 mA on PD0-PD7. Iol = 20 mA on INIT, STB, SLIN, AFD ① Iol = 2.0 mA on other outputs.
Voh	Output High Voltage	2.4		V	Ioh = -0.4 mA on DB0-DB7. Ioh = -15.0 mA on PD0-PD7. Ioh = -0.55 mA on INIT, AFD, STB, SLIN. Ioh = -0.2 mA on other outputs.
Icc	Power Supply Current		80	mA	Vcc = 5.5V MSTRX1 = 48 MHz All other inputs = 5.5V. All outputs floating Baud Rate = 512K. Serial Port CLK = 8 MHz.
Iil ②	Input Leakage		±15	µA	Vcc = 5.5V, Vss = 0.0V. All other pins float.
Icl	Clock Leakage				Vin = 0.0V, 5.5V.
Idl	Data Bus Leakage (DB and PD)		±10	µA	Vout = 0.4V, Vout = 4.5V Data Bus in High Impedance State.
Ioz	Tristate Leakage		± 20	µA	Vcc = 5.5V, GND = 0V, Vout = 0.0V, 5.5V.
Vil (RES)	Reset Schmitt Vil		0.8	V	
Vih (RES)	Reset Schmitt Vih	2.3		V	

TABLE 6-2. DC OPERATING CHARACTERISTICS

- ① The SLIN, AFD, STB and INIT outputs are all open collector with 2.5K to 3.5K Ohms internal pull-up resistors. In PS/2 mode IRQ7 is also an open collector. When in Vol state, each input sinks a minimum of 10 mA.
- ② RESCPU, IRQ3 - 7, IRQ8, IRQ9 - 12, IRQ14 - 15, ROM8, A20GT, KBINT, AND CS1 have nominally 300 µA pullups. These pullups, along with all others, are disabled when the 48 MHz oscillator is disabled by asserting CS0, CS1, and CS2 simultaneously. The pulldowns on KBCLK, ATCLK, and CLK287 are enabled when the three chip selects are low and sink 40 mA min.



#### 6.4 AC OPERATING CHARACTERISTICS AND TIMING

Ta = 0°C (32°F) to +70°C (158°F), Vss = +5V ± 5%, VDD2 = +5V ± 5%  
Table 6-1 lists the timing categories and their Figure and Table number.

FIGURE NUMBER	TABLE NUMBER	FIGURE TITLE
6-1	6-4	Receiver Timing
6-2	6-5	Transmitter Timing
6-3	6-6	MODEM Control Timing
6-4	6-7	Read Cycle Timing
6-5	6-7	Write Cycle Timing
6-6	6-4	RCVR FIFO Signaling Timing for First Byte
6-7	6-4	RCVR FIFO Signaling Timing after First Byte (RBR already set)
6-8	6-8	Parallel Port Timing
6-9	6-8	Parallel Port Interrupt Timing
6-10	6-9	Clock Generation Timing
6-11	6-10	Interrupt MUX Timing (A)
6-12	6-10	Interrupt MUX Timing (B)

**TABLE 6-3. TIMING FIGURE/TABLE NUMBERS**

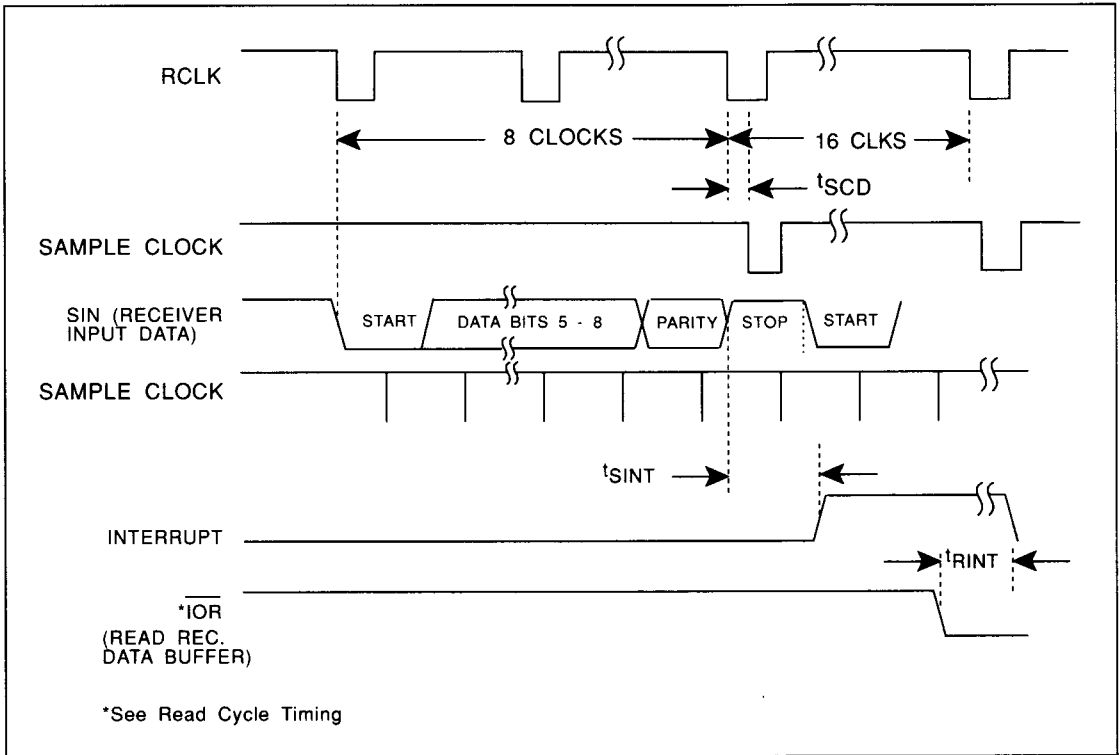

FIGURE 6-1. RECEIVER TIMING

SYMBOL	CHARACTERISTIC	MIN	MAX	UNITS	TEST CONDITIONS
$t_{SCD}$	Delay from RCLK ② to Sample Time		2	$\mu$ s	
$t_{SINT}$	Delay from Stop to Set Interrupt		17 ①	RCLK ② Cycles	100 pF Load
$t_{RINT}$	Delay from $\overline{IOR}$ (RD RBR) Reset Interrupt		250	ns	100 pF Load

TABLE 6-4. RECEIVER TIMING

① When receiving the first byte in FIFO Mode,  $t_{SINT}$  (only for timeout or trigger level interrupt) will be delayed 19 RCLK cycles, except for a timeout interrupt where  $t_{SINT}$  will be delayed 24 RCLK cycles.

② RCLK is an internal clock used for sampling serial in data. RCLK is equivalent to 16 times the baud rate clock.



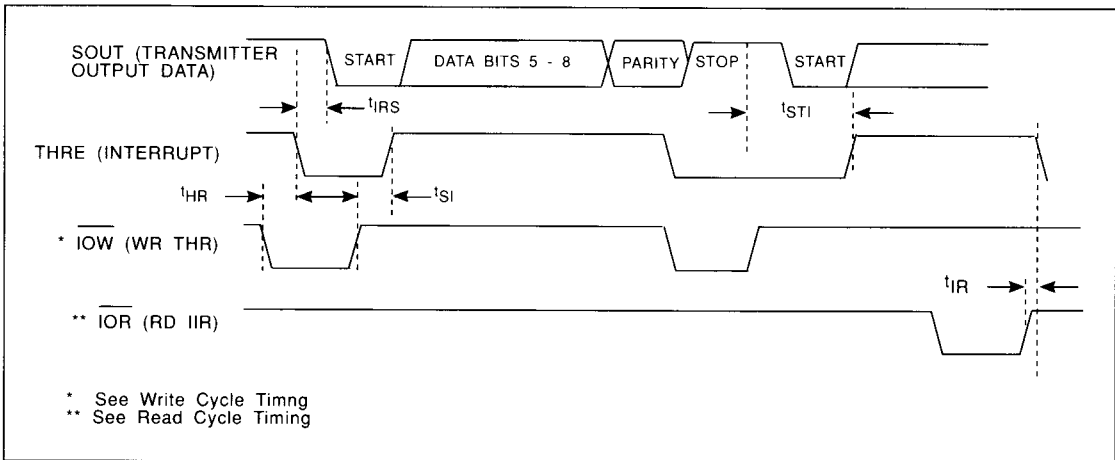

FIGURE 6-2. TRANSMITTER TIMING

SYMBOL	CHARACTERISTIC	MIN	MAX	UNITS	TEST CONDITIONS
$t_{HR}$	Delay from $\overline{IOW}$ (WR THR) to Reset Interrupt		175	ns	100 pF Load
$t_{IRS}$	Delay from initial INTR Reset to Transmit start	8	24	TCLK <sup>①</sup> Clock Cycles	
$t_{SI}$ <sup>②</sup>	Delay from Initial Write to Interrupt	16	24	TCLK <sup>①</sup> Clock Cycles	
$t_{STI}$	Delay from Stop to Interrupt (THRE)	8	8	TCLK <sup>①</sup> Clock Cycles	
$t_{IR}$	Delay from $\overline{IOR}$ (RD IIR to Reset Interrupt (THRE)		250	ns	100 pF Load

TABLE 6-5. TRANSMITTER TIMING

<sup>①</sup> TCLK is an internal clock used for sending serial out data. TCLK is equivalent to 16 times the baud rate clock.

<sup>②</sup> In FIFO mode  $t_{SI}$  might extend to beginning of Stop Bit. See Line Status Register for details.

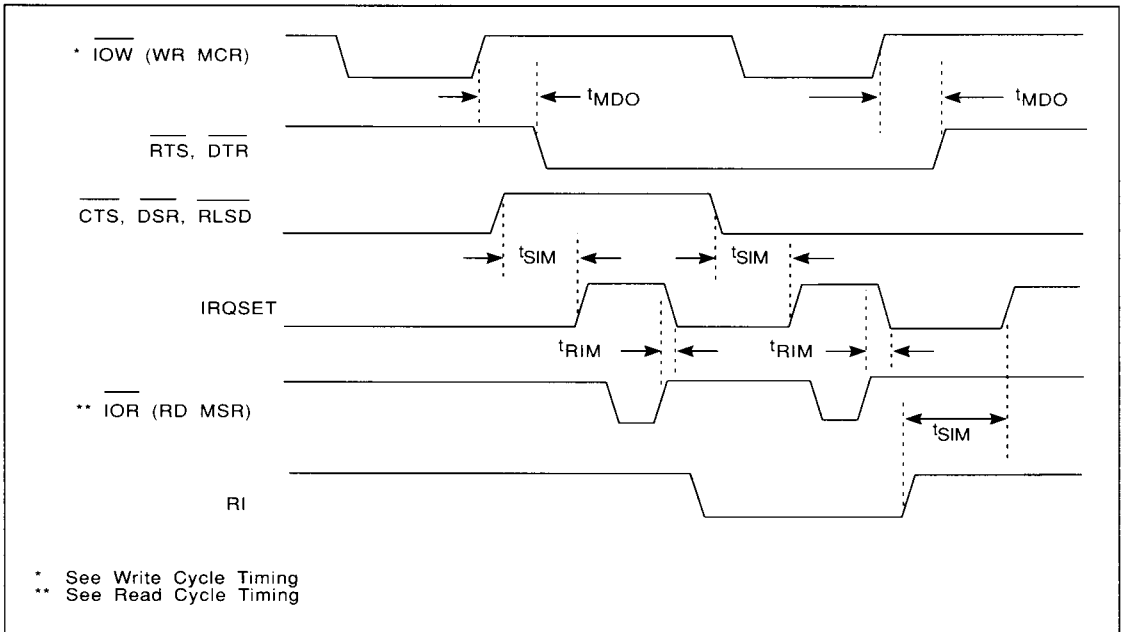

FIGURE 6-3. MODEM CONTROL TIMING

SYMBOL	CHARACTERISTIC	MIN	MAX	UNITS	TEST CONDITIONS
$t_{MDO}$	Delay from $\overline{IOW}$ (WR MCR) to Output		200	ns	100 pF Load
$t_{SIM}$	Delay to Set Interrupt from MODEM Input		250	ns	100 pF Load
$t_{RIM}$	Delay to Reset Interrupt from $\overline{IOR}$ (RD MSR)		250	ns	100 pF Load

TABLE 6-6. MODEM CONTROL TIMING





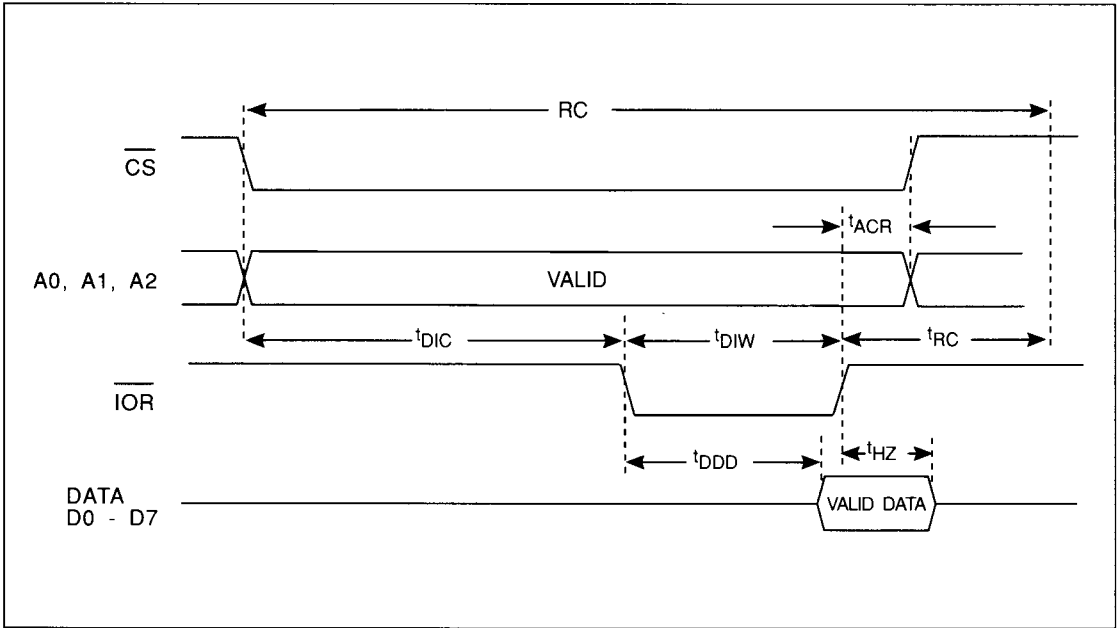

FIGURE 6-4. READ CYCLE TIMING

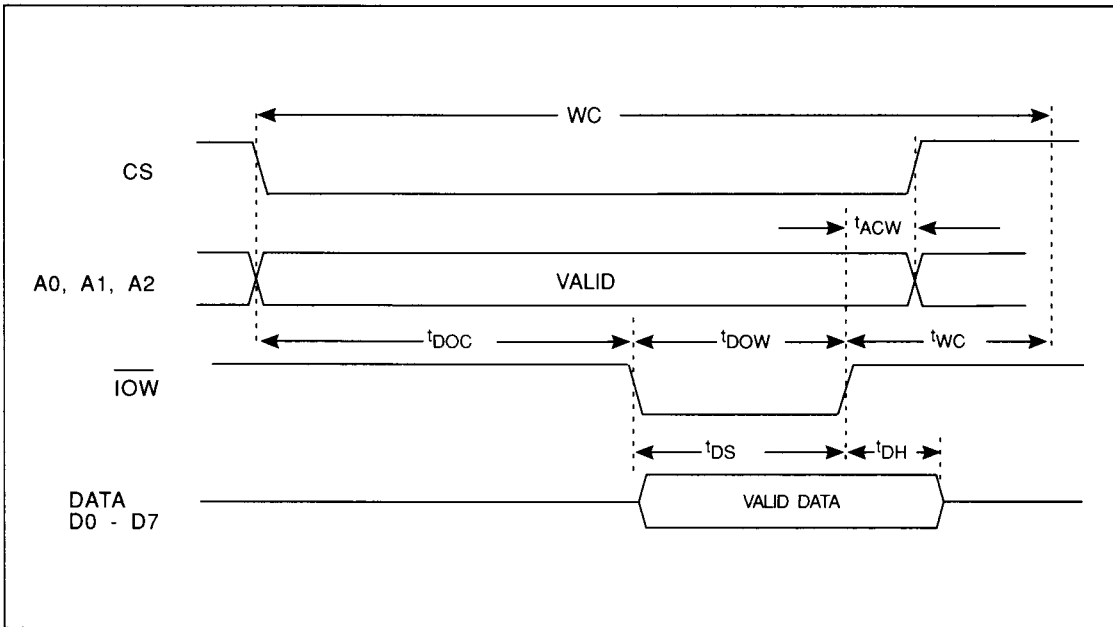

FIGURE 6-5. WRITE CYCLE TIMING



SYMBOL	CHARACTERISTIC	MIN	MAX	UNITS	TEST CONDITIONS
tDIW	$\overline{\text{IOR}}$ Strobe Width	125		ns	1TTL Load
tRC	Read Cycle Delay	125		ns	1TTL Load
RC	Read Cycle = tDIC + tDIW + tRC + 20 ns	300		ns	1TTL Load
tHZ	$\overline{\text{IOR}}$ to Floating Data Delay	0	100	ns	1TTL Load
tDOW	$\overline{\text{IOW}}$ Strobe Width	100		ns	1TTL Load
tWC	Write Cycle Delay	150		ns	1TTL Load
WC	Write Cycle = + tDOC + tDOW + tWC + 20 ns	300		ns	1TTL Load
tDS	Data Setup Time	30		ns	1TTL Load
tDH	Data Hold Time	30		ns	1TTL Load
tDIC	$\overline{\text{IOR}}$ DELAY from Select or Address	30		ns	1TTL Load
tDOC	$\overline{\text{IOW}}$ Delay from Select or Address	30		ns	1TTL Load
tACR	Address and Chip Select Hold Time from $\overline{\text{IOR}}$	20		ns	1TTL Load
tACW	Address and Chip Select Hold Time from $\overline{\text{IOW}}$	20		ns	1TTL Load
tDDD	Delay from $\overline{\text{IOR}}$ to data		100	ns	1 TTL Load
tMR	Master Reset Pulse Width	1.0		$\mu\text{s}$	1 TTL Load
tPWRUP	Delay from TTL Clock in to internal clock on power up.		50	$\mu\text{s}$	
tOSCUP	Delay from OSC clock in to internal clock on power up.		30	ms	

TABLE 6-7. READ/WRITE CYCLE TIMING



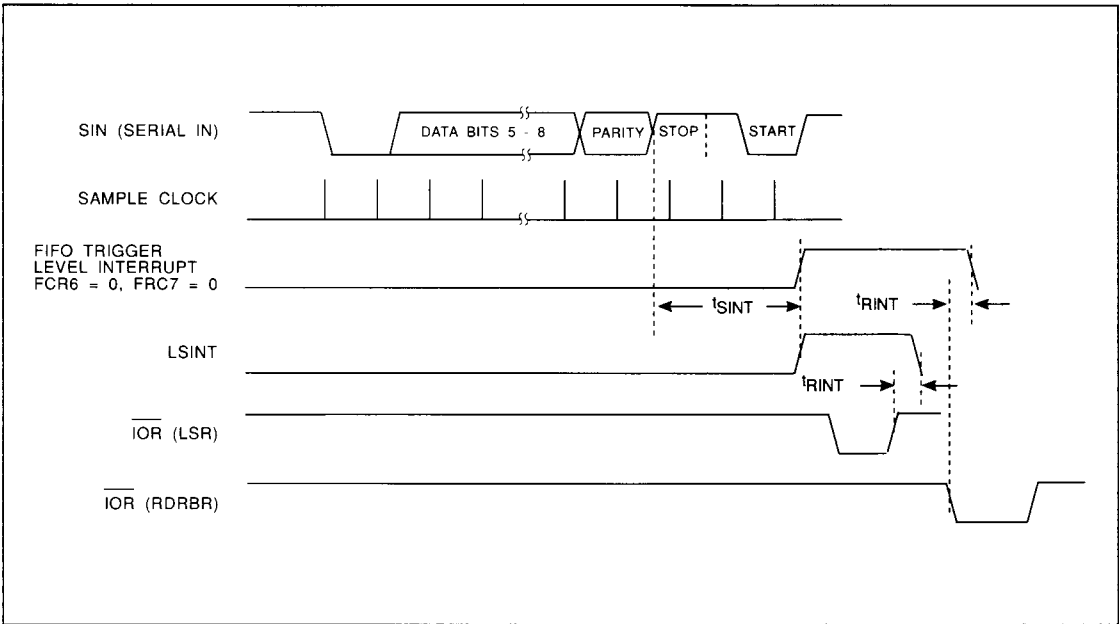

FIGURE 6-6. RCVR FIFO SIGNAL TIMING FOR FIRST BYTE

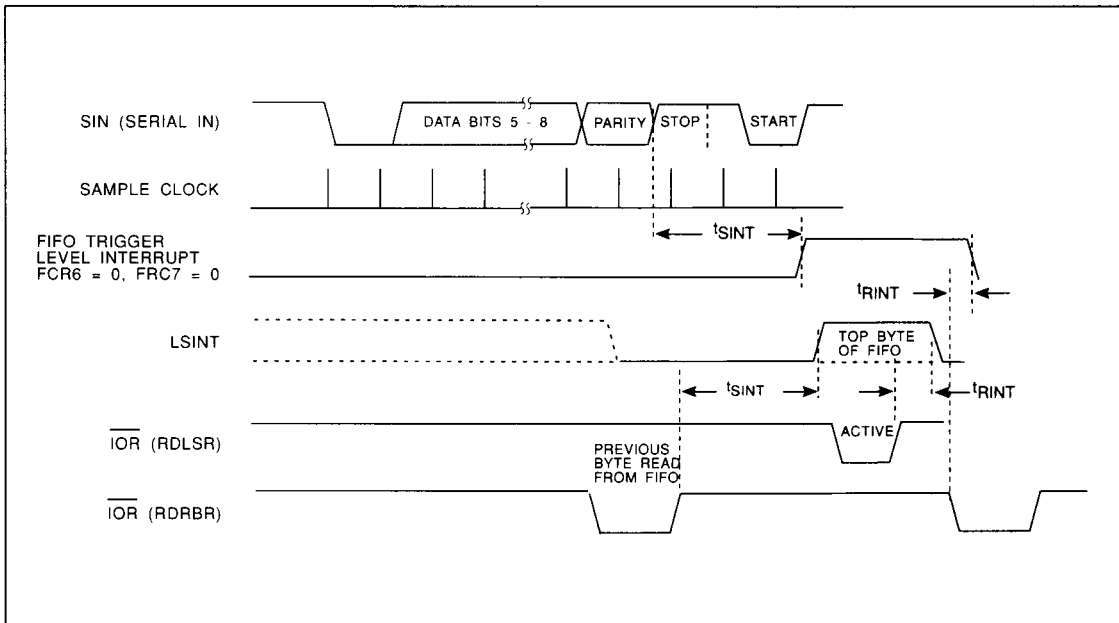

FIGURE 6-7. RCVR FIFO SIGNAL TIMING AFTER FIRST BYTE (RBR ALREADY SET)



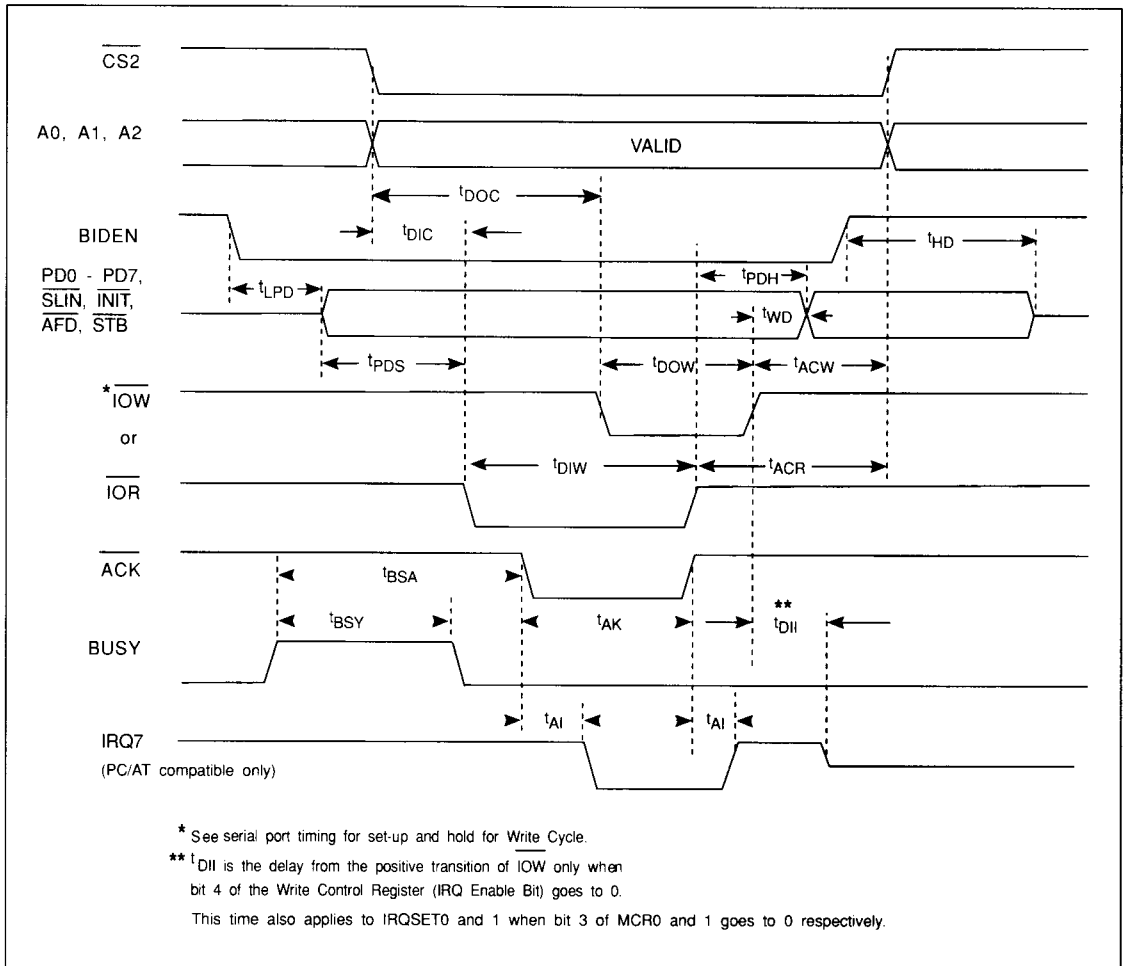

FIGURE 6-8. PARALLEL PORT TIMING

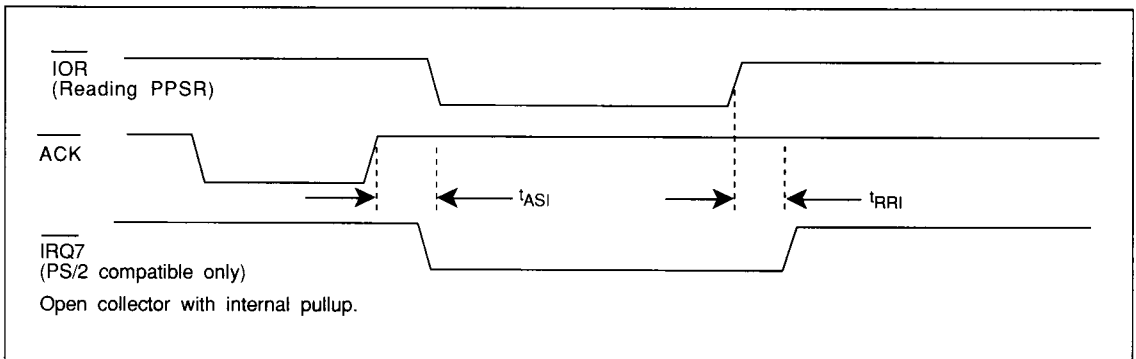

FIGURE 6-9. PARALLEL PORT INTERRUPT TIMING



SYMBOL	CHARACTERISTIC	MIN	MAX	UNITS	TEST CONDITIONS
t <sub>DOC</sub>	$\overline{IOW}$ Delay from Chip Select and Address	30		ns	
t <sub>DIC</sub>	$\overline{IOR}$ Delay from Chip Select and Address	30		ns	
t <sub>WD</sub>	$\overline{IOW}$ High to PD0-PD7, SLIN, INIT, AFD, STB		1	$\mu$ s	No External Pull-up Resistor and 50 pF Load
t <sub>HD</sub>	BIDEN High to PD0-PD7 Tri-State		120	ns	50 pF Load
t <sub>LPD</sub>	BIDEN Low to PD0-PD7 Delay		100	ns	50 pF Load
t <sub>PDH</sub>	PD0-PD7 Hold Time from $\overline{IOR}$	100		ns	
t <sub>PDS</sub>	PD0-PD7 Set-up Time from $\overline{IOR}$	100		ns	
t <sub>DOW</sub>	$\overline{IOW}$ Strobe Width	100		ns	
t <sub>DIW</sub>	$\overline{IOR}$ Strobe Width	125		ns	
t <sub>ACW</sub>	Chip Select and Address Hold Time from $\overline{IOW}$	20		ns	
t <sub>ACR</sub>	Chip Select and Address Hold Time from $\overline{IOR}$	20		ns	
t <sub>BSA</sub>	BUSY Start to $\overline{ACK}$	0		ns	
t <sub>BSY</sub>	BUSY Width	100		ns	
t <sub>AK</sub>	$\overline{ACK}$ Width	100		ns	
t <sub>AI</sub>	IRQ7 Delay from $\overline{ACK}$		60	ns	50 pF Load
t <sub>ASI</sub>	$\overline{ACK}$ to set interrupt		60	ns	50 pF Load
t <sub>RRI</sub>	Read Parallel Port Status Register (PPSR)		60	ns	50 pF Load
t <sub>DII</sub>	$\overline{IOW}$ to Tri-State	0	100	ns	50 pF Load

TABLE 6-8. PARALLEL PORT TIMING

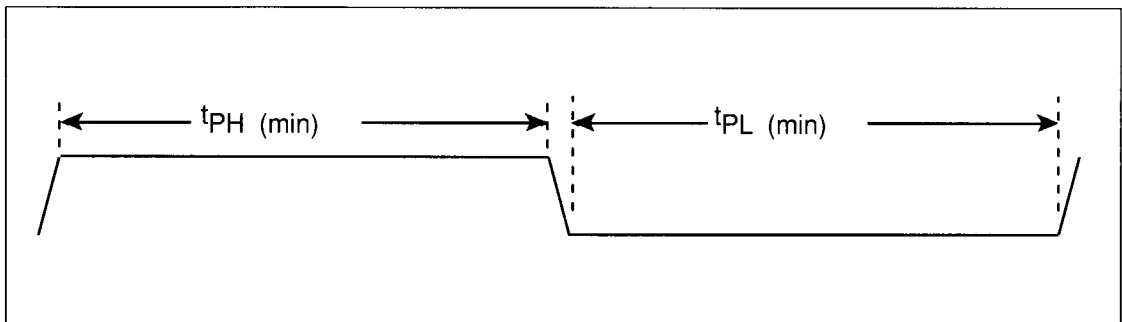

FIGURE 6-10. CLOCK GENERATION TIMING

CLOCK TYPE	$t_{PH}$ min. ns.	$t_{PL}$ min. ns.	FREQUENCY MHz	MAX. EDGE DELAY ① FROM MSTRX1 EDGE
CLK287 SEL				
0	40	68	8	100 ns
1	28	60	9.6	100 ns
2	20	50	12	100 ns
3	35	35	12	100 ns
4	14	35	16	100 ns
5	25	25	16	100 ns
KBCLK	50	33	9.6	100 ns
ATCLK	27	25	16	100 ns
MSTRX1	8	8	48	N/A

TABLE 6-9. CLOCK GENERATION TIMING

① All 50 pF loads

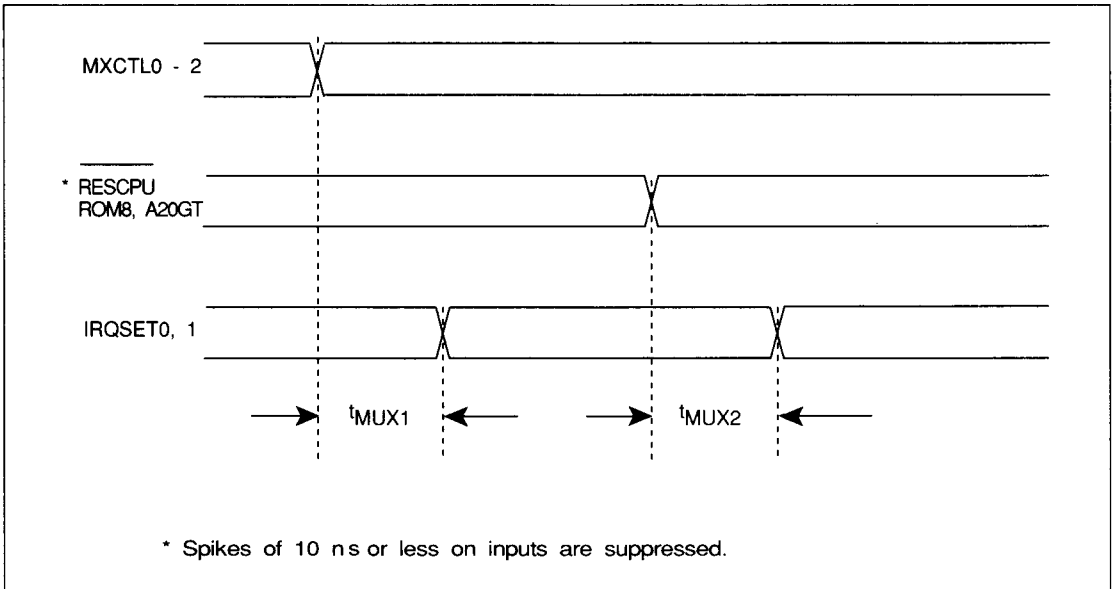

FIGURE 6-11. INTERRUPT MUX TIMING - A

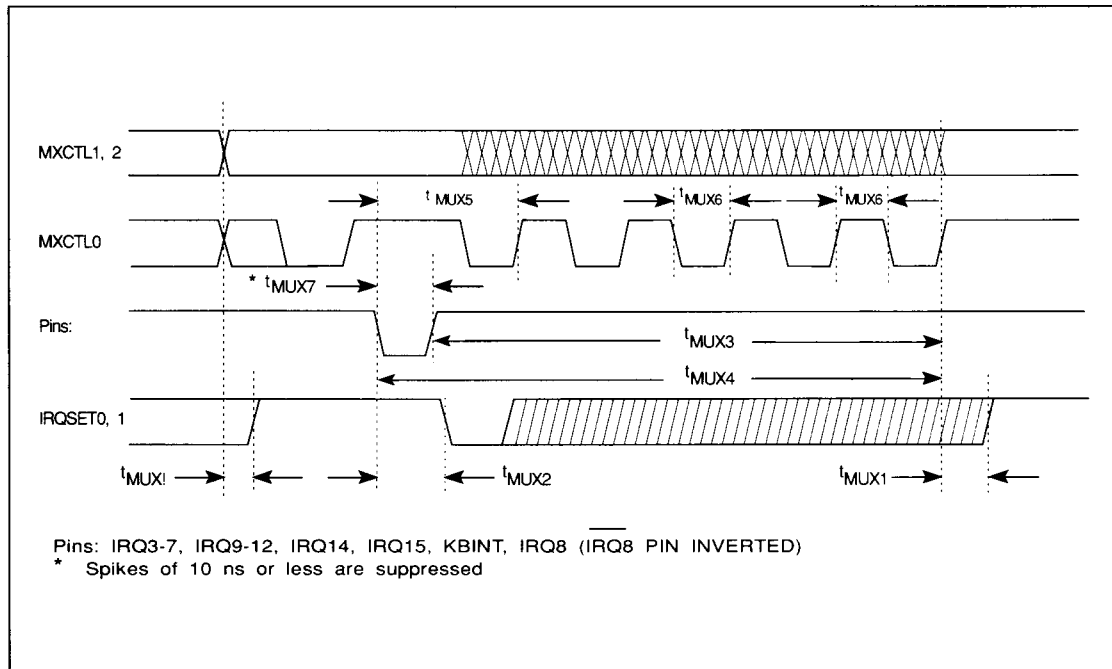

FIGURE 6-12. INTERRUPT MUX TIMING - B

SYMBOL	CHARACTERISTIC	MIN	MAX	UNITS	TEST CONDITIONS
t <sub>MUX1</sub>	Delay from MUX control change		25	ns	50 pF load
t <sub>MUX2</sub>	Delay from MUX input going low		125	ns	50 pF load
t <sub>MUX3</sub>	Rising MXCTL0 clock edges required	3	5		
t <sub>MUX4</sub>	Rising MXCTL0 clock edges required	5			
t <sub>MUX5</sub>	MUX input setup time	100		ns	
t <sub>MUX6</sub>	MXCTL0-2 pulse width	40		ns	
t <sub>MUX7</sub>	Pins pulse width	75		ns	

TABLE 6-10. INTERRUPT MUX TIMING





PIN NUMBER	SIGNAL NAME	① INPUT/OUTPUT	② SERIAL ③ PARALLEL POWER DOWN	② FULL ③ POWER DOWN
50	DTR0	O	OZ	OZ
83	DTR1	O	OZ	OZ
49	RTS0	O	OZ	OZ
84	RTS1	O	OZ	OZ
82, 51	SOUT1, 0	O	OZ	OZ
40	ATCLK ⑤ ⑦	O, P	O, PZ	OZ, PL
38	CLK287 ⑥ ⑦	O, P	O, PZ	OZ, PL
37	KBCLK ⑤ ⑦	O, P	O, PZ	OZ, PL
2, 1	IRQSET1, 0	O	O	OZ
23	IRQ7	I, O, P	I, O, PH	IX, OZ, PZ
57-62, 65, 66	PD7-0	I, O	IX, OZ	IX, OZ
76	BIDEN ⑧	I, P	IX, PZ	IX, PZ
71	ERROR	I	IX	IX
72	SLCT	I	IX	IX
74	PE	I	IX	IX
75	ACK	I	IX	IX
73	BUSY	I	IX	IX
69	INIT	I, O, P	IX, OZ, OZ	IX, OZ, OZ
70	SLIN	I, O, P	IX, OZ, PZ	IX, OZ, PZ
67	STB	I, O, P	IX, OZ, PZ	IX, OZ, PZ
68	AFD	I, O, P	IX, OZ, PZ	IX, OZ, PZ
48	CS0	I	I	I
46	CS2	I	I	I
47	CS1	I, P	I, PH	I, PZ
53	RLSD0	I	IX	IX
52	CTS0	I	IX	IX
54	RI0	I	IX	IX
55	DSR0	I	IX	IX
81	CTS1	I	IX	IX
80	RLSD1	I	IX	IX
79	RI1	I	IX	IX
78	DSR1	I	IX	IX
77, 56	SIN1, 0	I	IX	IX
6-4	MXCTL2-0	I	I	IX
8-11	IRQ3-6	I, P	I, PH	IX, PZ
12	IRQ8	I, P	I, PH	IX, PZ
13-15, 19	IRQ9-12	I, P	I, PH	IX, PZ
17, 18	IRQ14, 15	I, P	I, PH	IX, PZ
16	ROM8	I, P	I, PH	IX, PZ
20	A20GT	I, P	I, PH	IX, PZ

TABLE 6-11. STATE OF PINS AT POWER DOWN

PIN NUMBER	SIGNAL NAME	① INPUT/OUTPUT BUFFER	② SERIAL ③ PARALLEL POWER DOWN	② FULL ③ POWER DOWN
21	$\overline{\text{KBINT}}$	I, P	I, PH	IX, PZ
7	$\overline{\text{RESCPU}}$	I, P	I, PH	IX, PZ
32-24	$\overline{\text{D7-0}}$	I, O	I, O	IX, OZ
41	$\overline{\text{IOW}}$	I	I	IX
42	$\overline{\text{IOR}}$	I	I	IX
43-45	$\overline{\text{A2-A0}}$	I	I	IX
36	RESET	I	I	I
35	MSTRX1 ④	I, O	I, OB	I, OH
34	MSTRX2	O	O	OL

①	② POWER DOWN STATE	
<b>BUFFER TYPE</b>	OZ = Tri-state output	I = Input enabled
I = Input buffer	O = Driven output	IX = Input disabled, consumes no power, input between 0V and 5V
O = Output buffer	OH = Output driven high	PH = Pullup enabled
P = Pullup or pulldown	OL = Output driven low	PL = Pulldown enabled
	OB = Output driven to oscillator BIAS point	PZ = Pullup or pulldown disabled

③ Serial/Parallel Power Down: PUD = 1 (bit 3 of the Mode Selection Register described in section 5.5). Full Power Down:  $\overline{\text{CS2}}$ ,  $\overline{\text{CS1}}$  and  $\overline{\text{CS0}}$  on pins 46, 47 and 48 are low simultaneously. This has priority over PUD.

④ When driven by a TTL oscillator, MSTRX1 requires an input low current ( $I_{il}$ ) of approximately 1 mA. To eliminate this in full power down mode, the TTL oscillator driving MSTRX1 must be disabled or driven to +5 volts.

⑤ KBCLK and ATCLK can be programmed to stop with their outputs remaining low. Stopping is not synchronous and is separate from what happens during a full power down.

⑥ CLK287 can be programmed to stop with its output remaining high or low. Stopping is synchronous and is separate from what happens in full power down.

⑦ When entering full power down, the drivers for KBCLK, ATCLK and CLK287 are tri-stated and are driven low by a pulldown FET that is only enabled during a full power down. This FET sinks a minimum of 45  $\mu\text{A}$ , and drives the output low when connected to a CMOS input. Stopping is not synchronous.

⑧ BIDEN has an external pullup so that applications requiring a high can leave it floating.

TABLE 6-11. STATE OF PINS AT POWER DOWN Cont.



### 7.0 PACKAGE DIMENSIONS

Figure 7-1. Illustrates the 84-Pin PLCC package showing the dimensions in inches.  
 Figure 7-2. Illustrates the 84-Pin PQFP package showing the dimensions in inches.

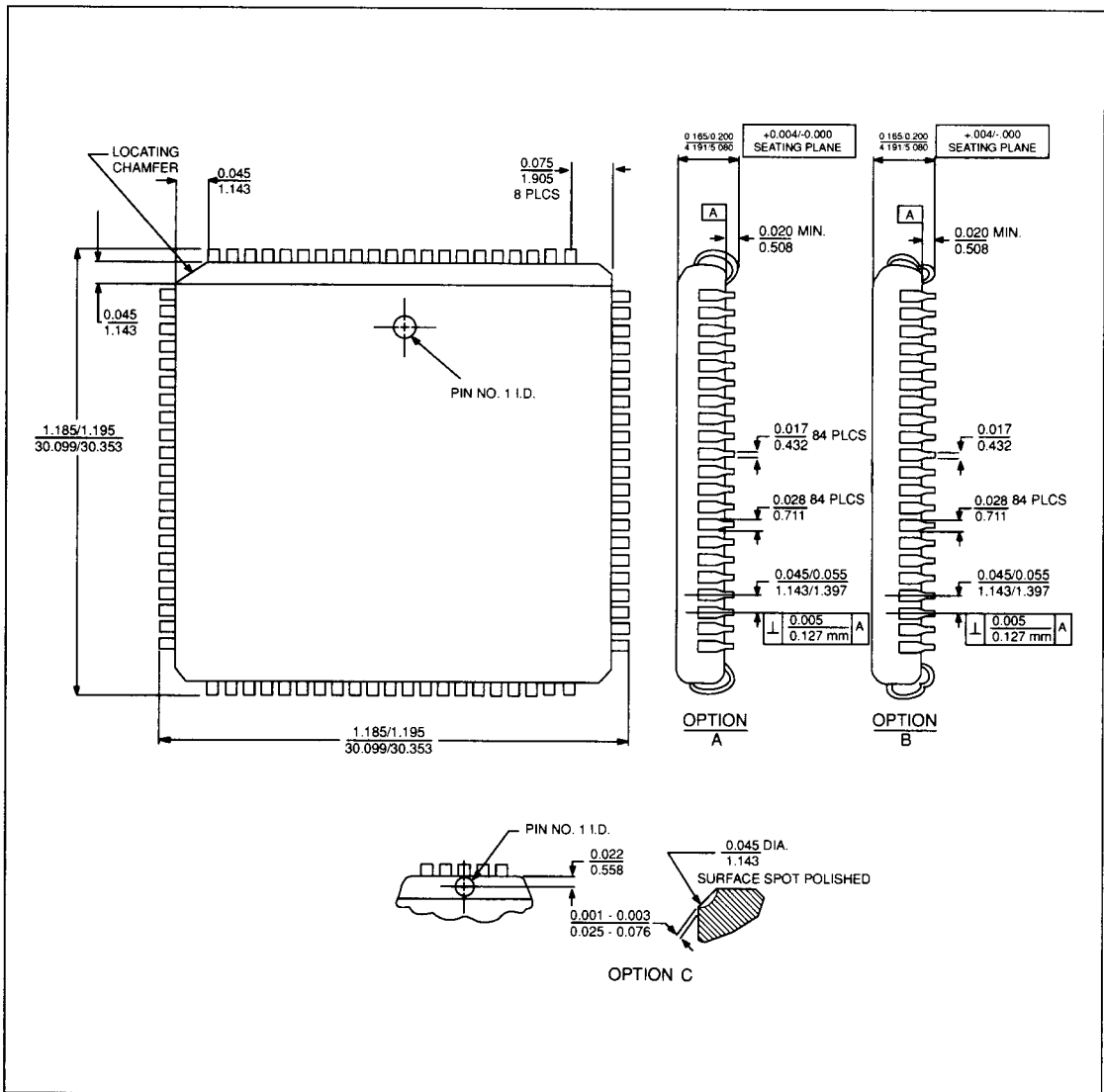

FIGURE 7-1. 84-PIN PLCC PACKAGE

8



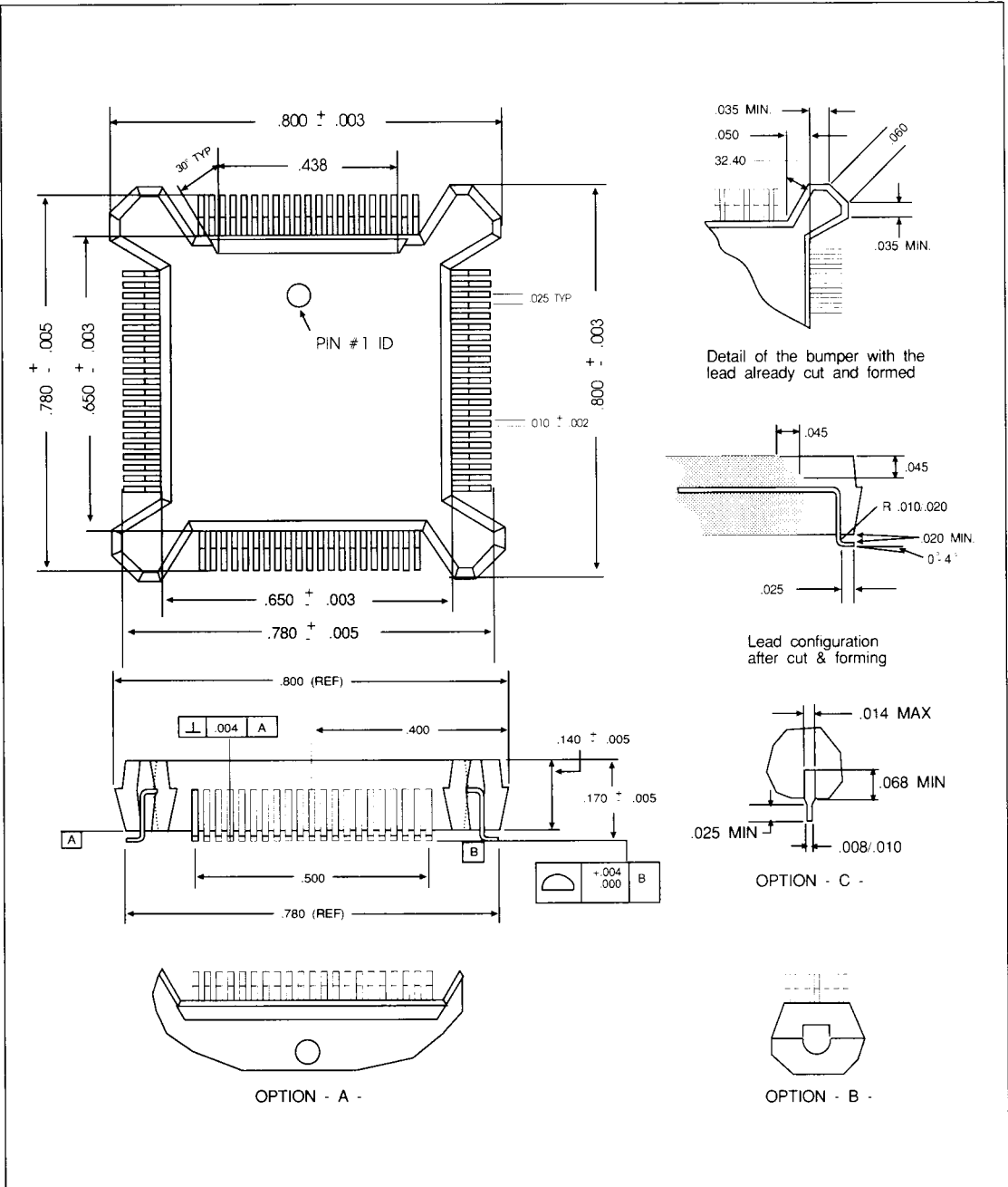

FIGURE 7-2. 84-PIN PQFP PACKAGE



### 8.0 CRYSTAL MANUFACTURES (Partial List)

American Time Products Division  
 Frequency Control Products, Inc.  
 Woodside, New York 11377

Bliley Electric Company  
 Eire, Pennsylvania 16508

Cryster Crystals  
 Whitby, Ontario

Erie Frequency Control  
 Carlisle, Pennsylvania 17013

Q-Matic Corporation  
 Costa Mesa, California 92626

### 8.1 CRYSTAL SPECIFICATIONS

Series resonant frequency tolerance at 25° C	48.0 MHz ± 50 PPM
Series resonant frequency tolerance at 0° C TO 70° C	48.0 MHz ± 100 PPM
Mode of oscillation	Third over-tone
Adjacent spurious frequency	20 db down, min.
Effective series resistance	80 ohms, max.
Shunt capacitance	5 pf max.
Drive level at room temperature	2000 microwatts
Operating temperature	0° C to 70° C
Insulation resistance	500M ohms/DC100V

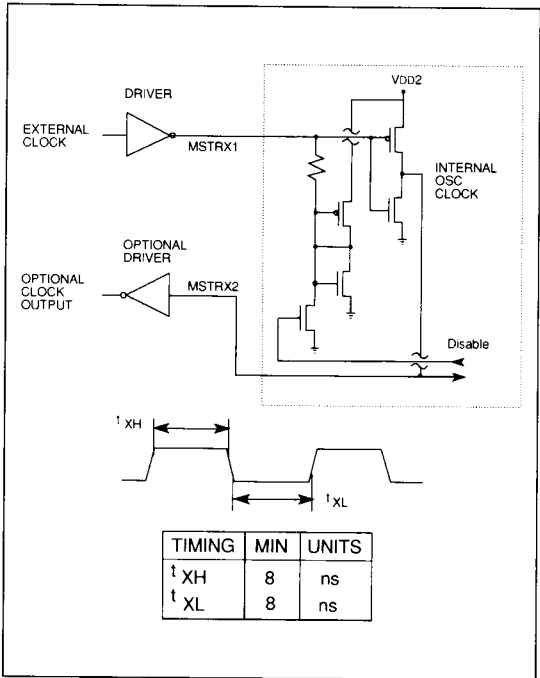

FIGURE 8-1. EXTERNAL CLOCK INPUT (48 MHz MAX.)

8

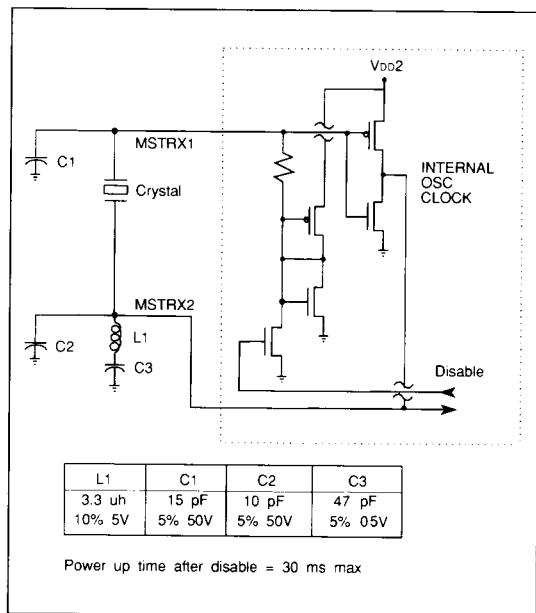

FIGURE 8-2. TYPICAL CRYSTAL OSCILLATOR NETWORK