

### HV9904 Multi Converter Controller

#### Features

- Eliminates High Voltage Input Electrolytic Capacitor
- Smallest and Most Reliable Off-Line Solution
- Constant Current or Constant Voltage Mode Control
- Can be Operated Directly from Rectified AC Mains
- 10V to 400V Input Range Internal Regulator
- 1.5mA Operating Supply Current
- PLL Based Loop Control with Soft Start
- On-Time Varies Inversely with Input Voltage
- Frequency Varies with Load
- 2.5V Differential Sense
- Recommended for <10W Applications

#### Applications

- Universal Input Voltage LED driver
- Constant Current Source
- Battery Charger

#### Ordering Information

Package Options		
8 Pin Plastic DIP	8 Pin SOIC	Dice
HV9904P	HV9904LG	HV9904X

#### General Description

The Supertex HV9904 is a second order PWM controller designed to provide a constant average current output or a constant average voltage output from an input of 10V to 400V DC or directly from rectified AC mains up to 280V. The second order topology is capable of extremely high dynamic control range, allowing operation directly from rectified AC mains without the need for bulky and expensive high voltage input electrolytic capacitor.

The PWM control utilizes feed forward circuitry to compensate for large variations in input voltage (i.e. rectified AC) and a novel integrator lock loop PLL scheme to regulate a differentially sensed feedback node where the signal may be discontinuous. This feedback node could be a current sense resistor or divider from regulated output voltage. For a constant load the switching frequency will be nearly constant with a dither of a few kHz helping to meet FCC conducted emissions requirements.

A high input voltage linear regulator provides a stable Vdd supply for the internal circuitry and gate drive to the external MOSFET. Under voltage lockout provides a power on reset and protection for the MOSFET

#### Typical Application Circuit

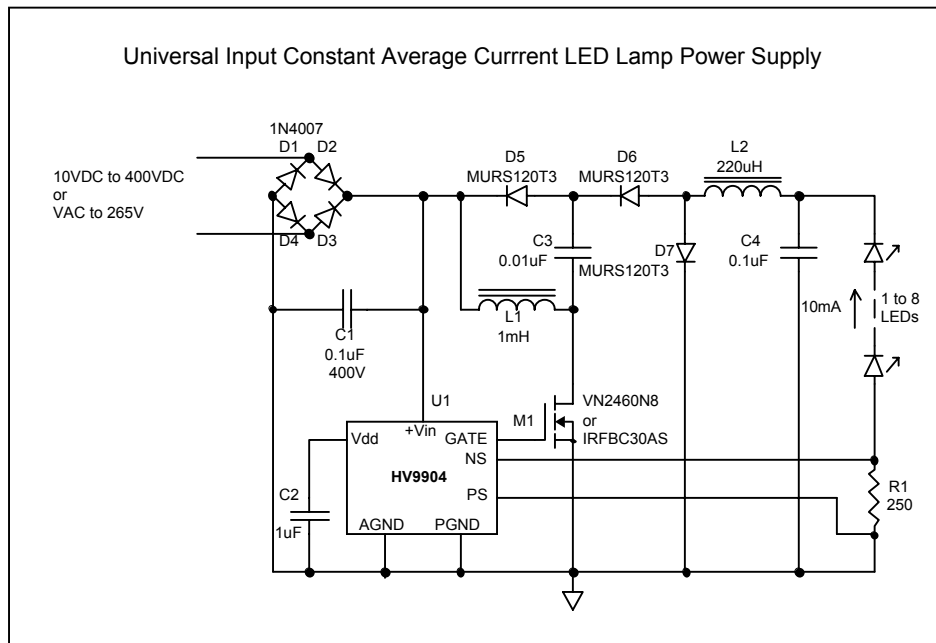

**Electrical Characteristics** (-40°C ≤ T<sub>A</sub> ≤ +85°C)

Symbol	Parameter	Min	Typ	Max	Units	Conditions
--------	-----------	-----	-----	-----	-------	------------

**Input Regulator/V<sub>DD</sub> Supply**

+V <sub>IN</sub>	Regulator Input Voltage	10		400	V	
+I <sub>IN</sub>	Input Current			1.5	mA	
V <sub>DD(REG)</sub>	Regulator Output Voltage		10		V	
V <sub>DD(RIPPLE)</sub>	Maximum Ripple Voltage			1	V(P-P)	
UVLO	Under Voltage Lockout Threshold		8		V	
UVLO	Under Voltage Lockout Hysteresis		0.5		V	

**MOSFET Gate Drive Output**

t <sub>R</sub>	Rise Time			75	nSec	C <sub>OUT</sub> = 750pF
t <sub>F</sub>	Fall Time			75	nSec	C <sub>OUT</sub> = 750pF

**PWM**

P <sub>MIN</sub>	Minimum Output Pulse Width		200	300	nSec	+V <sub>IN</sub> = 400V
P <sub>MAX</sub>	Maximum Output Pulse Width	2			uSec	+V <sub>IN</sub> = 15V
f <sub>MIN</sub>	Minimum Output Frequency	10			kHz	+V <sub>IN</sub> = 15V, V <sub>PS</sub> = 0V, V <sub>NS</sub> = -4V

**Current Sense**

V <sub>PS</sub> - V <sub>NS</sub>	Current Sense Voltage	2.3	2.5	2.7	V	-5V ≤ V <sub>PS</sub> ≤ 0V, -5V ≤ V <sub>NS</sub> ≤ 0V
-----------------------------------	-----------------------	-----	-----	-----	---	--

**Absolute Maximum Ratings\***

+V <sub>IN</sub> Input Voltage	-0.3V to +450V
Operating Ambient Temperature Range	-40°C to +85°C
Operating Junction Temperature Range	-40°C to +125°C
Storage Temperature Range	-65°C to +150°C
Power Dissipation @ 25°C, SOIC	750mW
Power Dissipation @ 25°C, Plastic DIP	750mW

\*All voltages referenced to AGND and PGND connected together.

**Pinout**

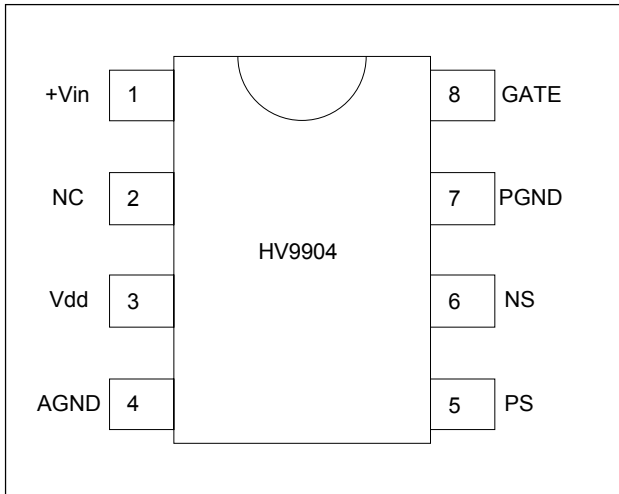

**Pin Description**

**+V<sub>IN</sub>** – This is the input to the internal linear regulator that provides the constant voltage VDD internal supply for the PWM. It can accept DC input voltages in the range of 10 to 400 Volts.

**V<sub>DD</sub>** – This is the output of the internal linear regulator and the supply pin for the PWM circuits. It must be bypassed with a capacitor capable of storing sufficient energy so that the voltage does not decay below the UVLO threshold during the time when the input voltage is below the minimum required by the regulator.

**NC** – No internal connection to this pin.

**AGRD** – Common connection for analog circuits.

**GATE** – This is the PWM output for driving the gate of an N-channel external MOSFET.

**PGRD** – Common connection for GATE drive circuit.

**NS** – This is negative sense input to the PWM control circuit.

**PS** – This is positive sense input to the PWM control circuit

**Functional Block Diagram**

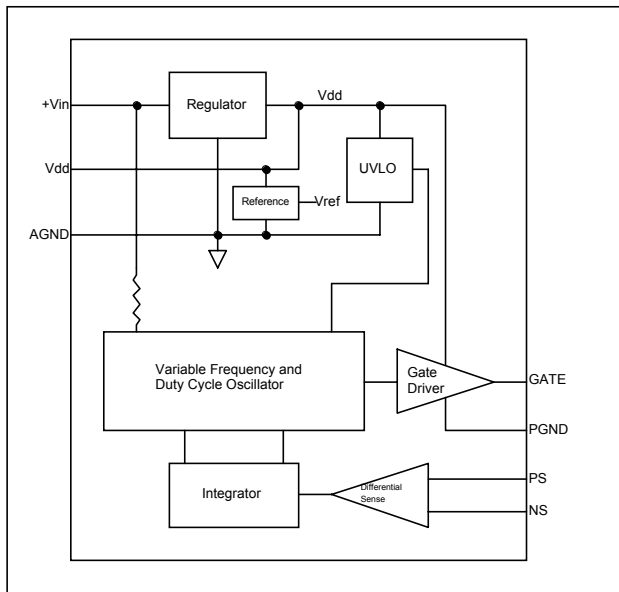

The duty cycle of the oscillator output and thus the on time of the MOSFET is determined by a feed forward circuit that sets the maximum on time based on the instantaneous value of the input voltage, thus avoiding core saturation of the magnetic elements. The oscillator is initially operating at its lowest frequency and continues to operate at this low frequency for several cycles to assure that a stable equilibrium state is reached. After this initial delay the feedback circuit is enabled and the oscillator frequency is increased in small steps on oscillator cycles until the PWM output (current or voltage) reaches the programmed value. Since the rate of increase in frequency is a function of the frequency the oscillator frequency will rise exponentially.

The differential sense circuit monitors the programming node (voltage on current sense resistor for constant average current control or voltage on resistive divider for constant average voltage control) using an integrator lock loop feedback to obtain a stable average value from even a discontinuous signal. As long as this average value is less than 2.5V the oscillator frequency is incremented. When the average value reaches 2.5V the oscillator frequency incrementing is halted. If the average value exceeds 2.5V then the oscillator frequency is decremented. In this manner the oscillator frequency is dithered to maintain output regulation while the feed forward sensing of the input voltage maintains a fixed value of energy transfer per oscillator cycle.

Line regulation is controlled by the instantaneous feed forward sensing of the input voltage, thus the PWM can easily track a full wave rectified sine wave of input voltage at 50Hz, 60Hz or 400Hz provided that the capacitor connected at Vdd can store sufficient energy to prevent decay below the UVLO threshold during the time when the resulting input voltage at +Vin is below 10V. For a 50Hz rectified sine wave a 1µF capacitor connected to Vdd is sufficient to guarantee stable operation at 50Hz.

Load regulation is controlled via the feedback sensing circuit by adjusting the oscillator frequency to maintain average energy transfer consistent with the load conditions. For relatively stable load conditions this method achieves excellent regulation. For a constant load the switching frequency will be nearly constant with a dither of a few kHz helping to meet FCC conducted emissions requirements.

**Functional Description**

On initial power application the high input voltage (10V to 400V) linear regulator charges the capacitor connected to Vdd and seeks to provide a stable supply for the internal circuitry and gate drive to the external MOSFET. Under voltage lockout (UVLO) holds the oscillator disabled and reset to its lowest frequency state until the Vdd supply rises above 8Volts assuring sufficient gate drive voltage for the external MOSFET. Once Vdd is above the UVLO threshold the oscillator is enabled and the external MOSFET is driven via the gate driver at the oscillator frequency. The UVLO has a 0.5V hysteresis to prevent false triggering due to ripple on Vdd.

## Application Information

### Non-Isolated Constant Current Output PWM

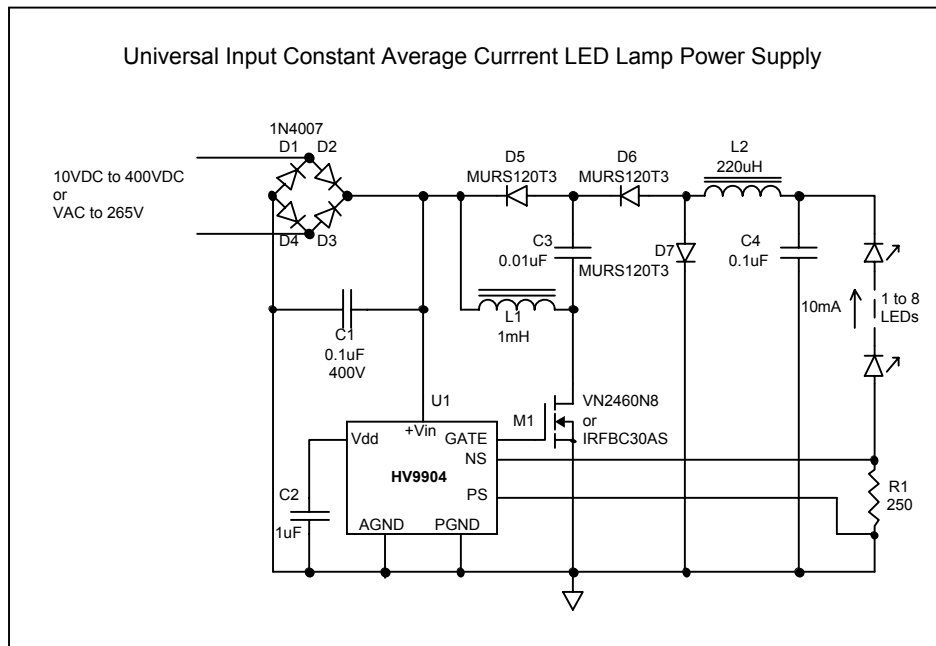

This circuit provides a constant average current output, which may be used to power LED lamps. The circuit maintains a constant average current and the value of C4 capacitor controls the peak-to-peak ripple, which decreases with increasing capacitor value. If

very high current ripple values are permissible then C4 may be omitted. The following BOM provides a list of suggested components.

Item Number	Quantity	Reference	Value	Manufacturer
1	1	C1	0.1µF, 500V	Vishay
2	1	C2	1µF, 15V	Vishay
3	1	C3	0.01µF, 500V	Vishay
4	1	C4	0.1µF, 25V	Vishay
5	4	D1, D2, D3, D4	1N4007	On Semiconductor
6	3	D5, D6, D7	MURS120T3	On Semiconductor
7	1	L1	DO1608C-105	Coilcraft
8	1	L2	DO1608C-224	Coilcraft
9	1	M1	VN2460N8	Supertex
10	1	R1	250Ω	
11	1	U1	HV9904LG	Supertex
<b>Total Part Count</b>	<b>16</b>			

Application Information - Continued

Non-Isolated Constant Voltage Output PWM

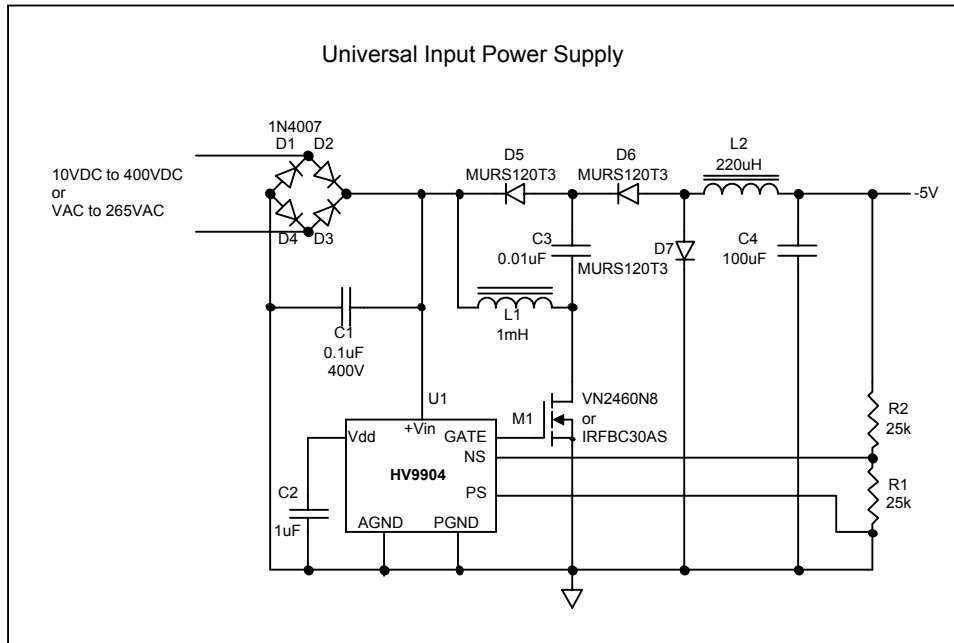

This circuit provides a non-isolated constant voltage output. The value of C4 capacitor controls the peak-to-peak ripple, which

decreases with increasing capacitor value. The following BOM provides a list of suggested components.

Item Number	Quantity	Reference	Value	Manufacturer
1	1	C1	0.1µF, 500V	Vishay
2	1	C2	1µF, 15V	Vishay
3	1	C3	0.01µF, 500V	Vishay
4	1	C4	100µF, 6.3V	Panasonic
5	4	D1, D2, D3, D4	1N4007	On Semiconductor
6	3	D5, D6, D7	MURS120T3	On Semiconductor
7	1	L1	DO1608C-105	Coilcraft
8	1	L2	DO1608C-224	Coilcraft
9	1	M1	VN2460N8	Supertex
10	1	R1	25kΩ	
11	1	R2	25kΩ	
12	1	U1	HV9904LG	Supertex
<b>Total Part Count</b>	<b>17</b>			