

# 40 Segment Static LCD Driver

## Features

- Serial data input / output
- Low dynamic current, 5  $\mu$ A max.
- Low standby current, 1  $\mu$ A max.
- Separate input and display voltages
- Wide power supply range:  
 $V_{DD}$  (logic) 2 to 8 V,  $V_{LCD}$  (display)  $V_{DD}$  to 12 V
- On-chip latches separate control and display sections
- Drives up to 40 LCD segments in direct drive
- Crossfree cascadable
- Schmitt Trigger on the inputs
- 30 ns (typ.) glitch filter on every input
- High noise immunity
- Segment outputs short circuit protected
- LCD blanking function
- - 40 to +85 °C temperature range
- On request extended temperature range,  
 - 40 to +125 °C
- QFP52 and TAB packages

## Description

The V6108 is a CMOS integrated circuit that drives LCD. The circuit drives up to 40 LCD segments from a serial clocked input. It has a serial output for cascading to further drives. The serially clocked data is parallel loaded into 40 latches under control of the strobe pin. The latched data determines which segments are ON or OFF. Any segment output can be used to drive a backplane. A blank function is provided to clear the display.

## Applications

- Balances and scales
- Automotive displays
- Utility meters
- Large displays
- Pagers
- Portable, battery operated products
- Telephones

## Typical Operating Configuration

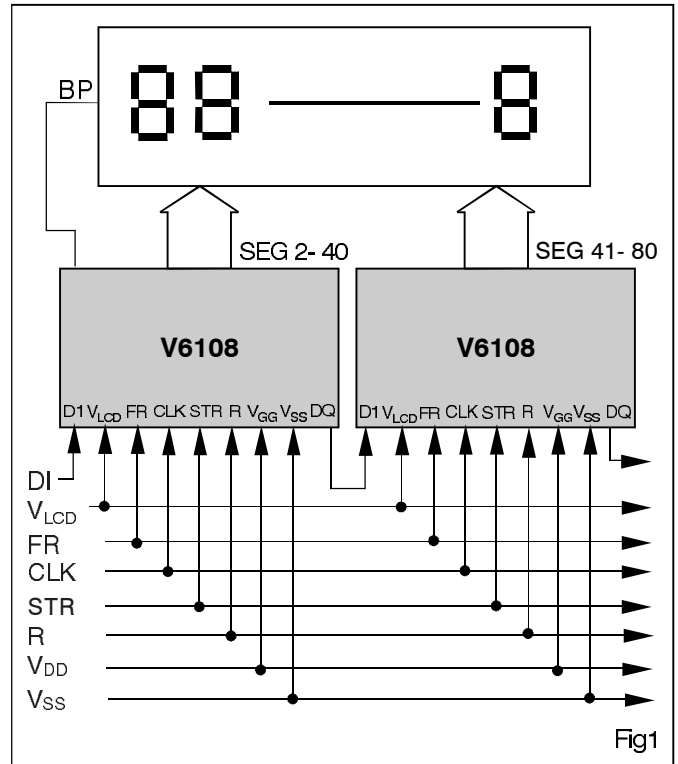

Fig1

## Pin Assignment

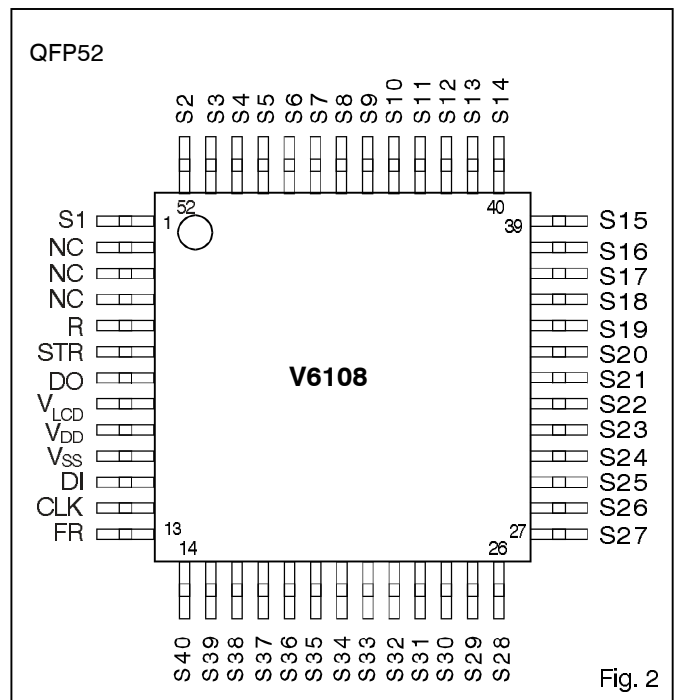
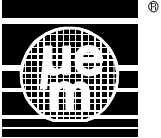

Fig. 2



## Absolute Maximum Ratings

Parameter	Symbol	Conditions
Logic supply voltage	V <sub>DD</sub>	-0.3V to +10V
LCD supply voltage <sup>1)</sup>	V <sub>LCD</sub>	-0.3V to +14V
Voltage at DI, CLK, STR, FR, R, DO	V <sub>LOGIC</sub>	-0.3V to V <sub>DD</sub> +0.3V
Voltage at S1 to S40	V <sub>DISP</sub>	V <sub>DD</sub> to V <sub>LCD</sub> + 0.3V
Storage temperature range	T <sub>STO</sub>	- 65 to +150 °C
Power dissipation	P <sub>MAX</sub>	100 mW
Electrostatic discharge max. to MIL-STD-883 C method 3015	V <sub>Smax</sub>	1000V
Max. soldering conditions	T <sub>S</sub>	250 °C x 10 s

<sup>1)</sup> V<sub>LCD</sub> has to be higher or equal to V<sub>DD</sub> Table 1  
Stresses above these listed maximum ratings may cause permanent damage to the device. Exposure beyond specified operating conditions may affect device reliability or cause malfunction.

## Electrical Characteristics

V<sub>DD</sub> = 5V ± 10%, V<sub>LCD</sub> = 12 V and T<sub>A</sub> = -40 to 85 °C, unless otherwise specified

Parameter	Symbol	Test Conditions	Min.	Typ.	Max.	Units
Static supply current	I <sub>DD</sub>	See note <sup>1)</sup>		0.1	1	μA
Static supply current	I <sub>LCD</sub>	See note <sup>1)</sup>		0.1	1	μA
Dynamic supply current	I <sub>DD</sub>	See note <sup>1)2)</sup>		55	75	μA
Dynamic supply current	I <sub>LCD</sub>	See note <sup>1)3)</sup>		0.6	5	μA
<b>All Input Signals</b>						
Low level input voltage	V <sub>IL</sub>				0.8	V
High level input voltage	V <sub>IH</sub>		3.8	3.5		V
Leakage Input current	I <sub>IL</sub>	V <sub>IN</sub> = V <sub>SS</sub> or V <sub>IN</sub> = V <sub>DD</sub>			1	μA
<b>Data Output DO</b>						
High level output voltage	V <sub>OH</sub>	I <sub>H</sub> = 100 μA V <sub>DD</sub> = V <sub>LCD</sub> = 4.5 V	V <sub>DD</sub> - 100			mV
Low level output voltage	V <sub>OL</sub>	I <sub>L</sub> = 100 μA V <sub>DD</sub> = V <sub>LCD</sub> = 4.5 V			V <sub>SS</sub> + 100	mV
<b>Driver Outputs S1...S40</b>						
High level output voltage	V <sub>SH</sub>	I <sub>H</sub> = 20 μA, V <sub>DD</sub> = V <sub>LCD</sub> = 4.5 V	V <sub>LCD</sub> - 100			mV
Low level output voltage	V <sub>SL</sub>	I <sub>L</sub> = 20 μA, V <sub>DD</sub> = V <sub>LCD</sub> = 4.5 V			V <sub>SS</sub> + 100	mV
Short Circuit Current	I <sub>SC</sub>	<b>only one output</b>		0.9	2	mA

<sup>1)</sup> Tested with V<sub>IL</sub> = V<sub>SS</sub>, V<sub>IH</sub> = V<sub>DD</sub>

<sup>2)</sup> Tested with f<sub>CL</sub> = 100 kHz, F<sub>DI</sub> = 50 kHz, 50 pF on each segment

<sup>3)</sup> Tested with f<sub>FL</sub> = 64 Hz, f<sub>CL</sub> = 0 Hz, 50 pF on each segment

Table 3

## Timing Characteristics

V<sub>DD</sub> = 5V ± 10%, V<sub>LCD</sub> = 12 V and T<sub>A</sub> = -40 to +85°C, unless otherwise specified

Parameter	Symbol	Test Conditions	Min.	Typ.	Max.	Units
Clock high pulse width	t <sub>CH</sub>		500			ns
Clock low pulse width	t <sub>CL</sub>		500			ns
Clock and FR rise time	t <sub>CR</sub>				500	ns
Clock and FR fall time	t <sub>CF</sub>				500	ns
Data input setup time	t <sub>DS</sub>		250			ns
Data input hold time	t <sub>DH</sub>		0			ns
Data output propagation	t <sub>PD</sub>	C <sub>LOAD</sub> = 50 pF		600	800	ns
CLK falling to STR rising	t <sub>P</sub>		50			ns
STR falling to CLK falling	t <sub>D</sub>		250			ns
STR pulse width	t <sub>STR</sub>		200			ns
FR frequency	f <sub>FR</sub>			64 Hz <sup>1)</sup>	1 <sup>2)</sup>	MHz
Delay S1 - S40 fall time	t <sub>SF</sub>			0.5	1	μs
Delay S1 - S40 rise time	t <sub>SR</sub>			2.9	5	μs

<sup>1)</sup> Recommended frame frequency.

<sup>2)</sup> Maximum test frequency.

Table 4

## Handling Procedures

This device has built-in protection against high static voltages or electric fields; however, anti-static precautions must be taken as for any other CMOS component. Unless otherwise specified, proper operation can only occur when all terminal voltages are kept within the supply voltage range. Unused inputs must always be tied to a defined logic voltage level.

## Operating Conditions

Parameter	Symbol	Min.	Typ.	Max.	Units
Operating temperature <sup>1)</sup>	T <sub>A</sub>	-40		+125	°C
Logic supply voltage	V <sub>DD</sub>	2.0		8	V
LCD supply voltage	V <sub>LCD</sub>	V <sub>DD</sub>		12	V

<sup>1)</sup> The maximum operating temperature is confirmed Table 2 by sampling at initial device qualification. In production, all devices are tested at +85 °C. On request devices tested at +125°C can be supplied.

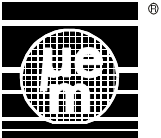

Timing Waveforms

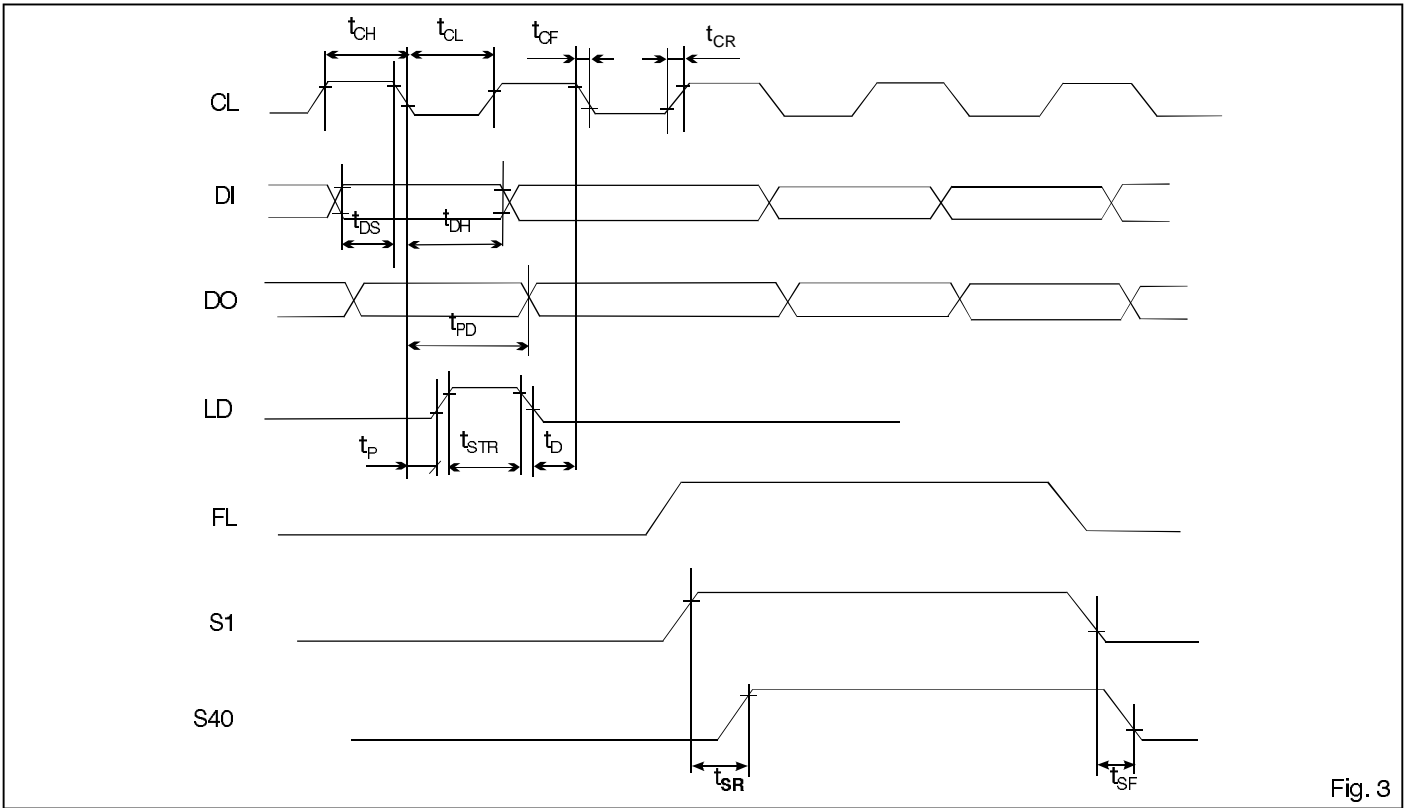

Fig. 3

$V_{OL}$  S1 ... S40 versus  $V_{LCD}$  at  $-40^\circ\text{C}$ ,  $+25^\circ\text{C}$  and  $+85^\circ\text{C}$

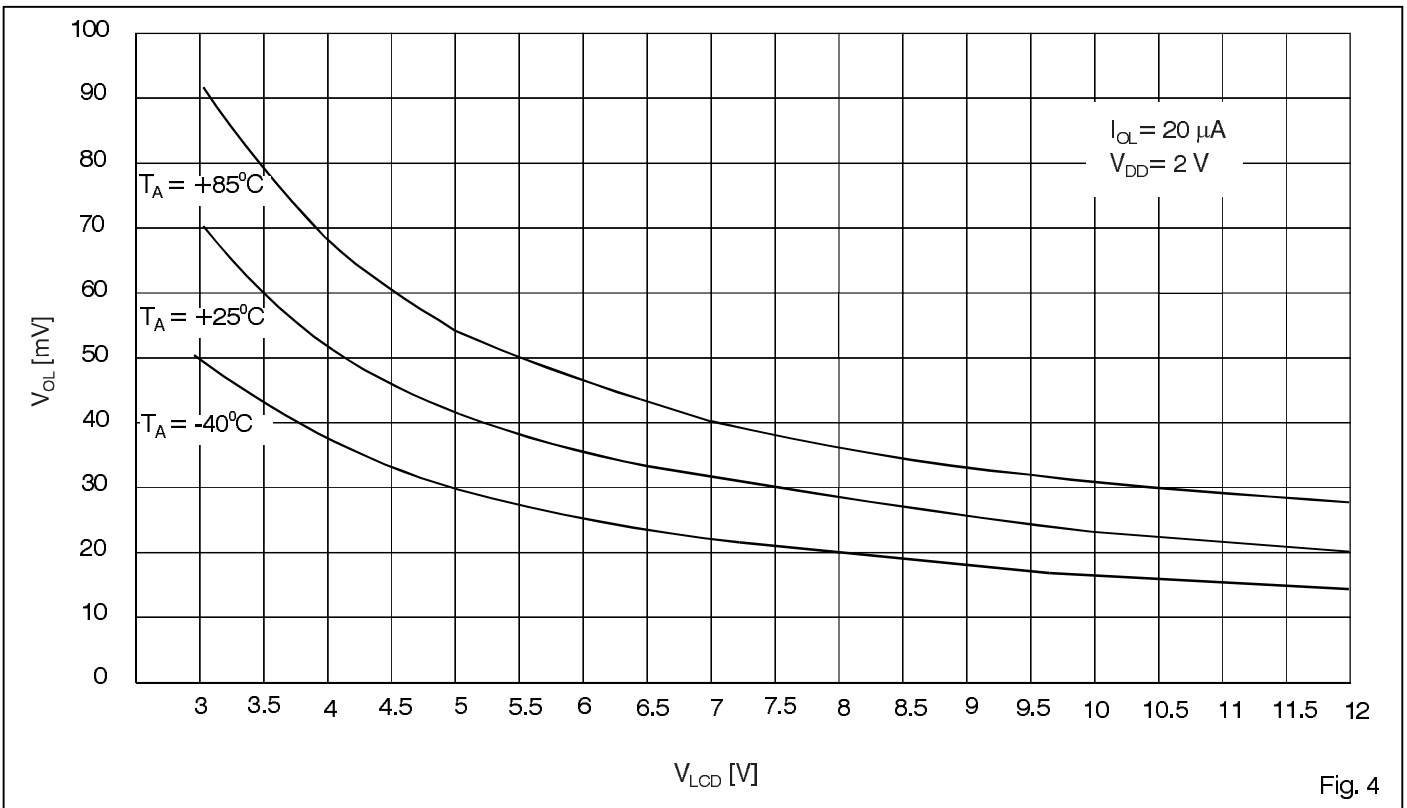
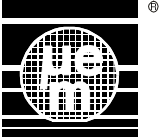

Fig. 4



## $V_{OH}$ S1 ... S40 versus $V_{LCD}$ at $-40^{\circ}\text{C}$ , $+25^{\circ}\text{C}$ and $+85^{\circ}\text{C}$

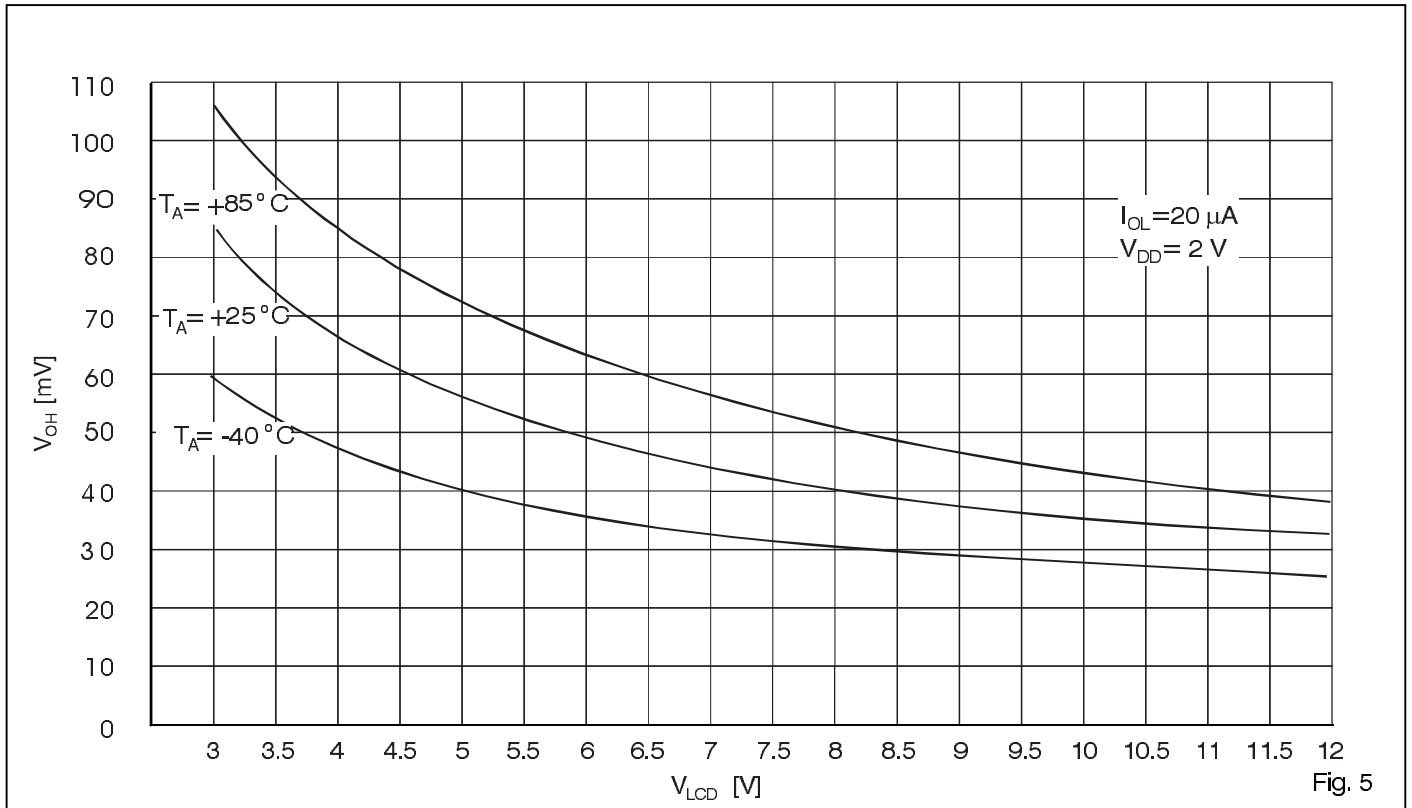

Fig. 5

## $V_{OL}$ DO versus $V_{DD}$ at $-40^{\circ}\text{C}$ , $+25^{\circ}\text{C}$ and $+85^{\circ}\text{C}$

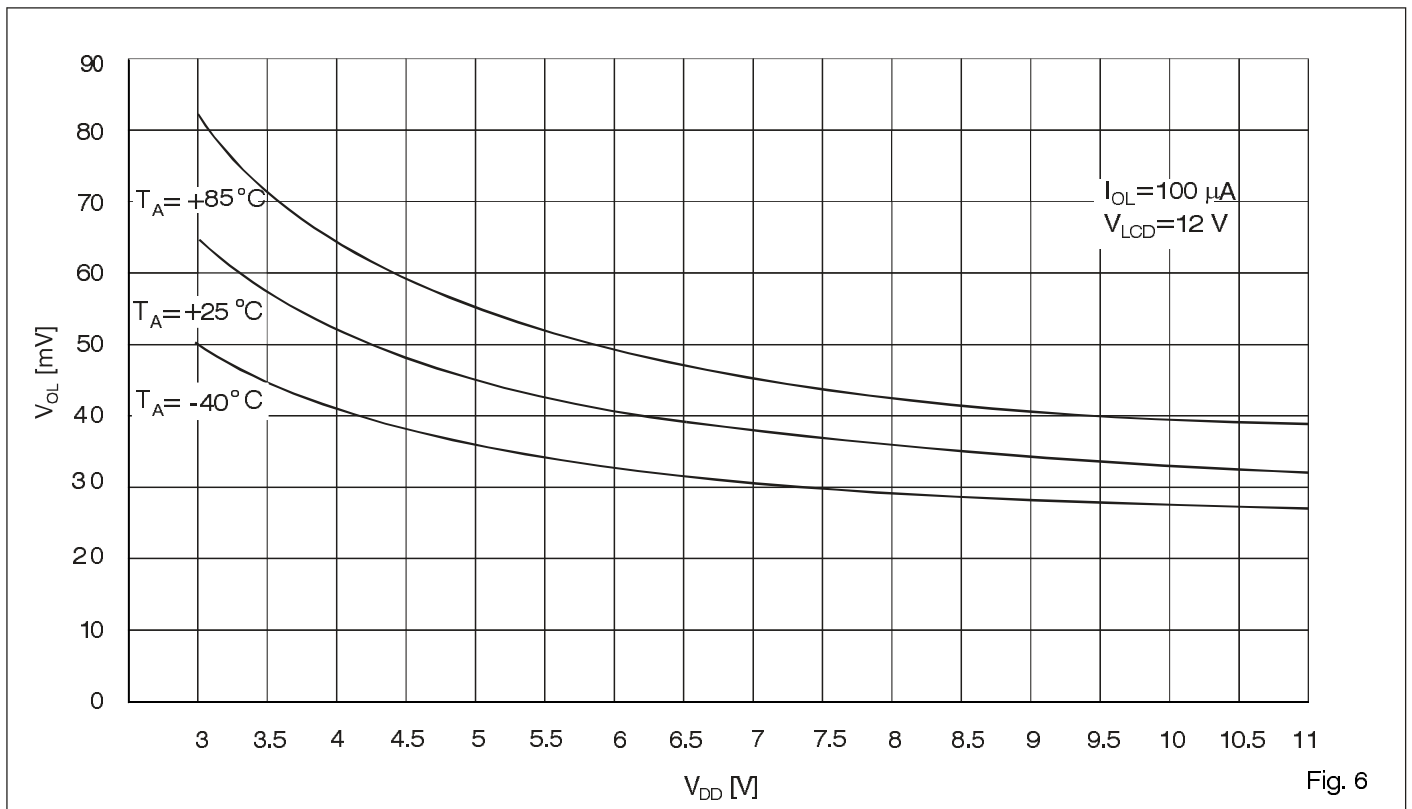
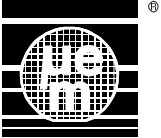

Fig. 6



## $V_{OH}$ DO versus $V_{DD}$ at $-40^{\circ}\text{C}$ , $+25^{\circ}\text{C}$ and $+85^{\circ}\text{C}$

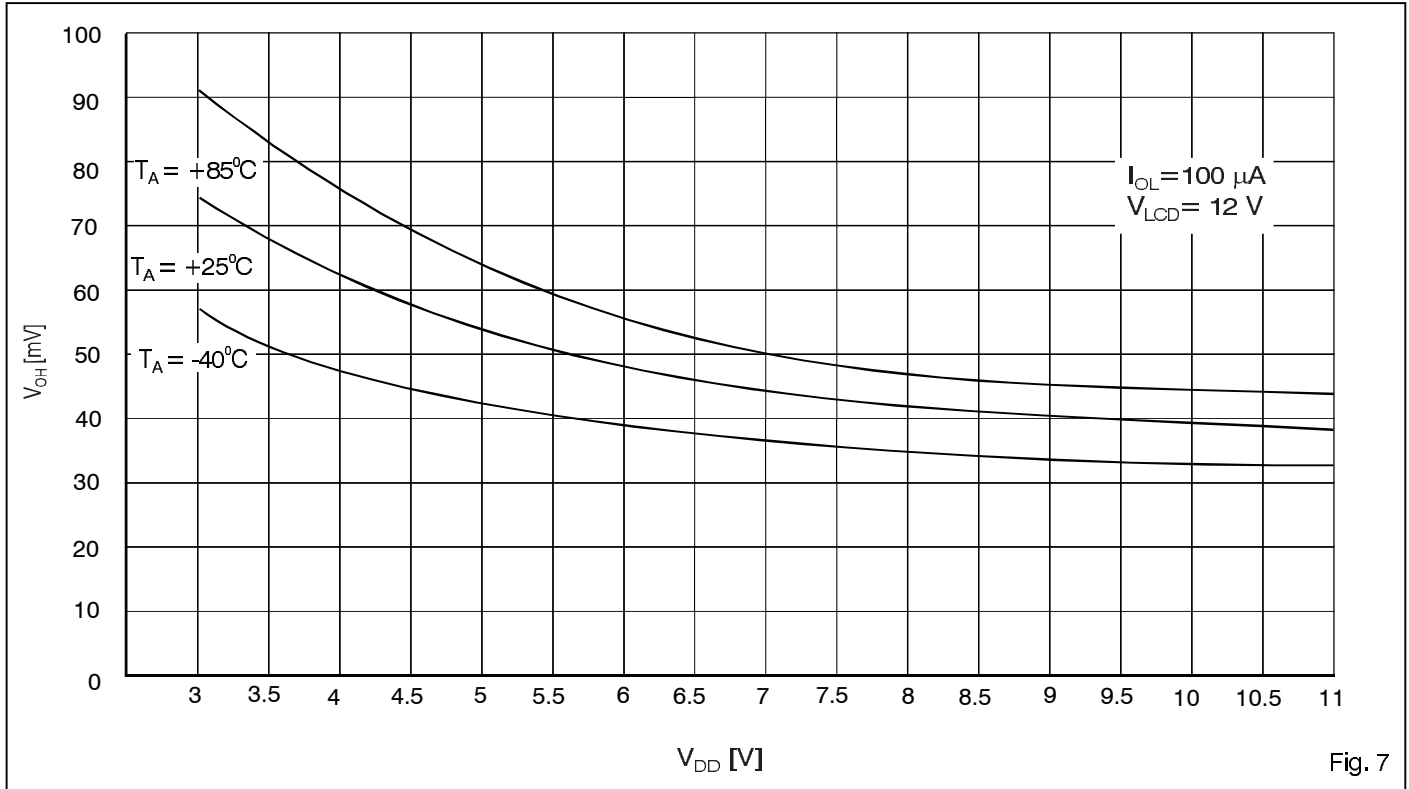

Fig. 7

## Block Diagram

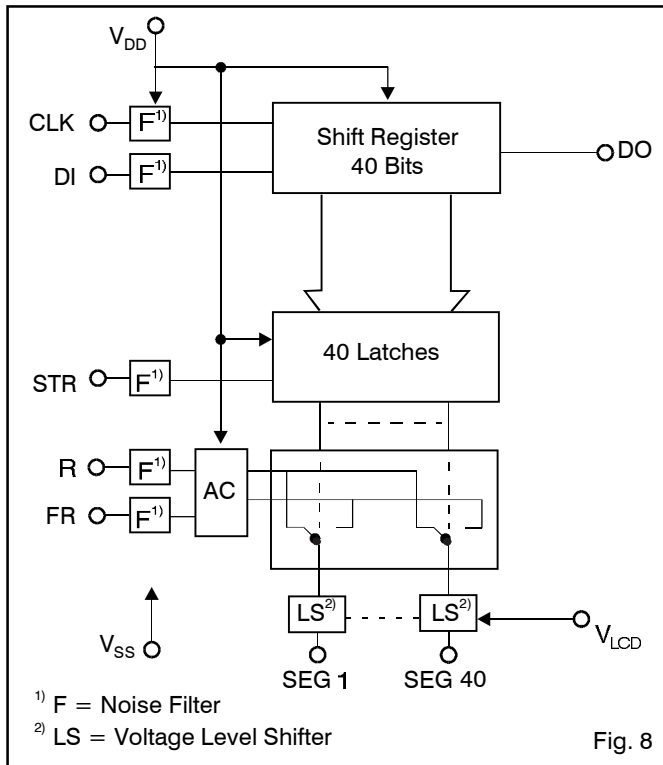

Fig. 8

## Pin Assignments

Name	Function
S1...S40	Segment drive outputs
$V_{LCD}$	Power supply for the LCD
$V_{DD}$	Power supply for logic
FR	Input for segment frequency control
DI	Serial data input
DO	Serial data output
CLK	Clock input
STR	Strobes the input data into the output latches
R	Display blank control input
$V_{SS}$	Supply ground

Table 5

## Functional Description

### Supply Voltages $V_{LCD}$ , $V_{DD}$ , $V_{SS}$

$V_{DD}$  is the positive supply line for the logic and  $V_{LCD}$  for the display signals.  $V_{LCD}$  has to be equal or higher than  $V_{DD}$ . All voltages are specified relative to  $V_{SS}$ .

### Data Input / Output (DI / DO)

The data input pin (DI) accepts serial data from the data source. The data is clocked in a rate determined by the clock input frequency (CLK). A logic "1" on DI corresponds to a visible segment when the backplane is driven by a signal corresponding to logic "0". The data at DO is equal to the data at DI delayed by 40 clock periods. In

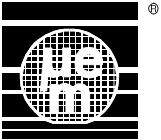

order to cascade devices the DO of one chip must be connected to DI of the following chip (see Fig. 1).

### CLK Input

The clock input pin (CLK) is used to clock the DI serial data into the 40-bit shift register. Loading, shifting and outputting of the data occurs at the falling edge of this clock (see Fig. 3). When cascading devices, all CLK lines should be tied together.

### STR Input

The strobe input pin (STR) is used to latch the input data shifted into the 40-bit shift register. The latched data is held for display. A logic "1" on the STR input transfers the data contained in the shift register cells to the corresponding latches. The latches remain open during the whole time STR remains at logic "1". When cascading devices the STR lines should all be connected.

### R Input

When R is active (high), the display is blanked: all segment outputs are tied to  $V_{SS}$ . R does not clear the information in the latches.

### Segment Driver

The number of segment drivers available on the chip is 40. Each segment driver can be used as backplane-driver. If two or more drivers are connected together, care must be taken to ensure the drivers do not cause circuit malfunction by driving one against the other.

### FR Input

This input controls the segment output switching frequency according to Table 6. It must be connected to an external clock signal. When cascading devices, their FR inputs may all be connected to a common signal.

### Segment Switching Table

Latched Signal (DI) 0 = $V_{IL}$ 1 = $V_{IH}$	Signal FR	Segment Voltage 0 = $V_{SS}$ 1 = $V_{LCD}$
0	0	0
0	1	1
1	0	1
1	1	0

Table 6

## Typical Applications

### Type V 6108 Circuits Driving an 79 Segment Display

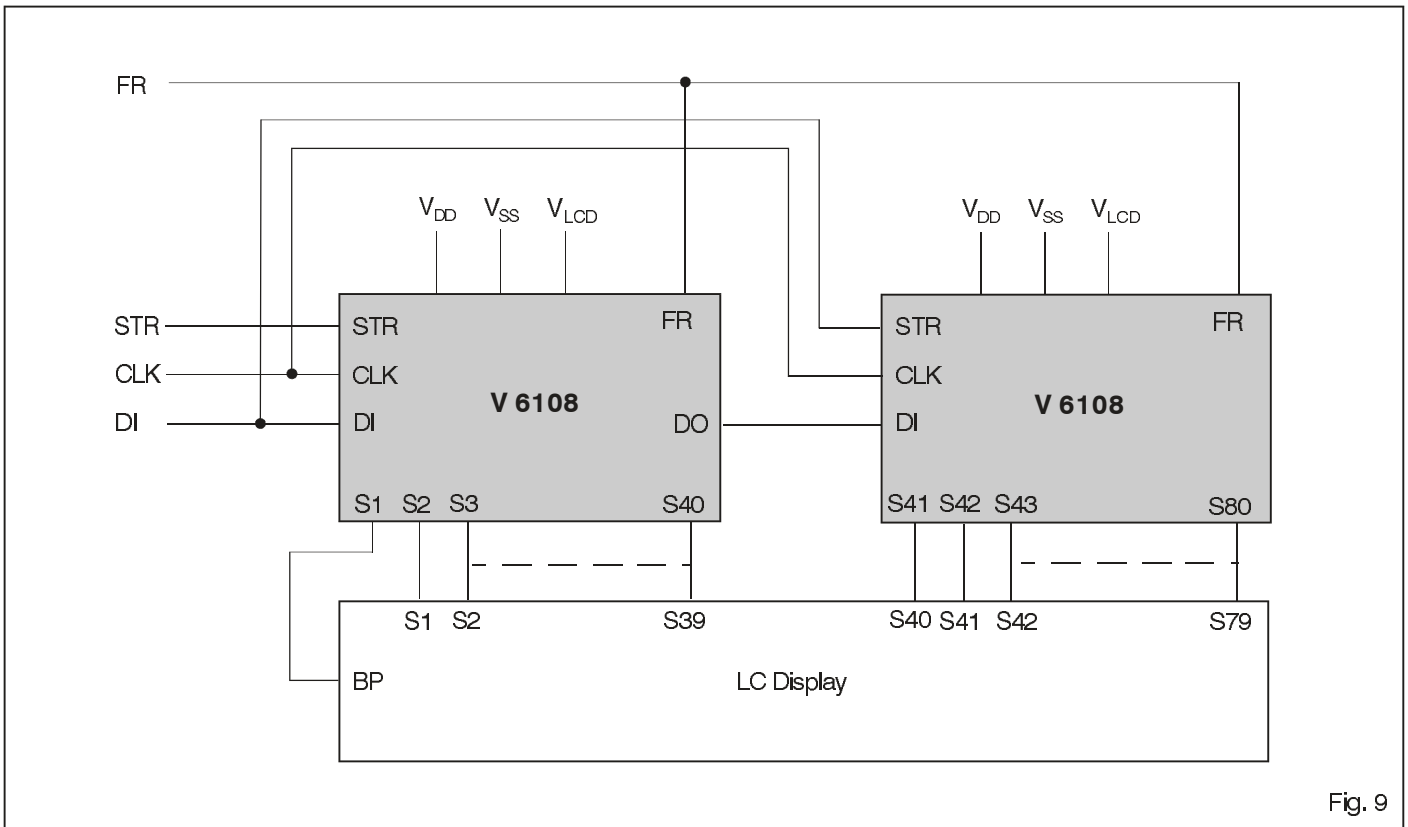
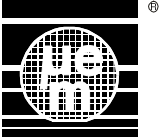

Fig. 9



## Cascaded V6108 TAB for Direct Drive Application

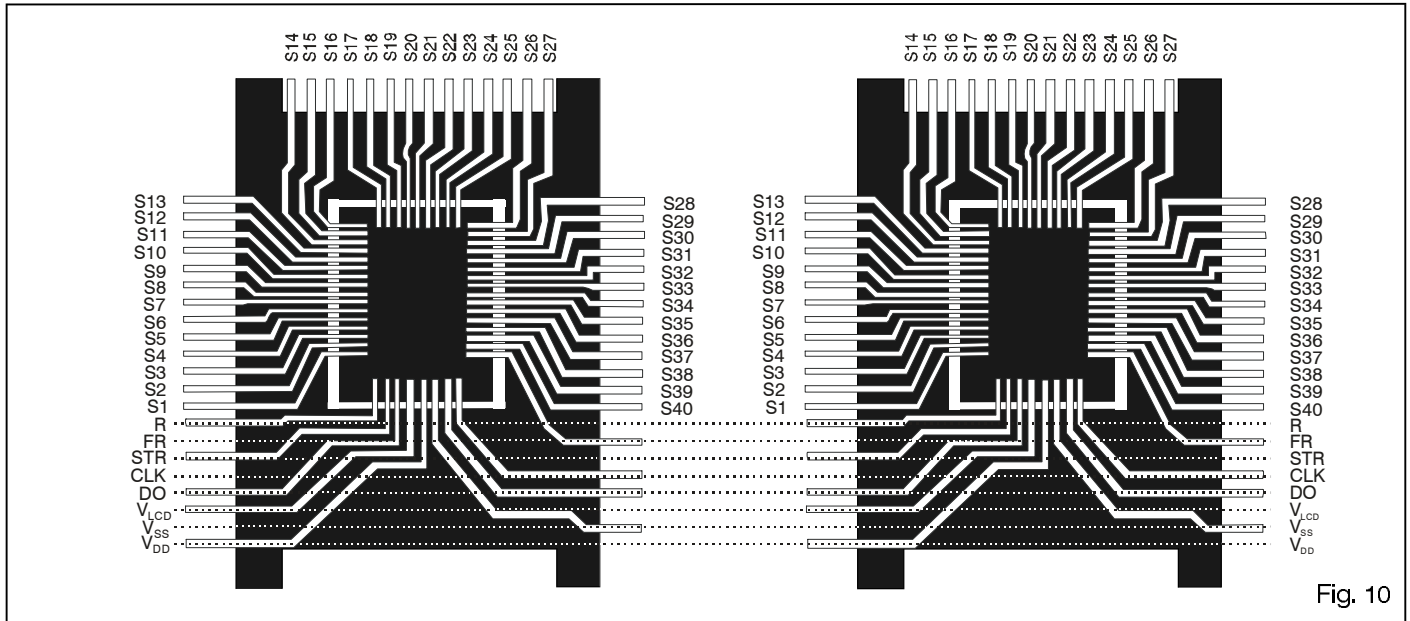
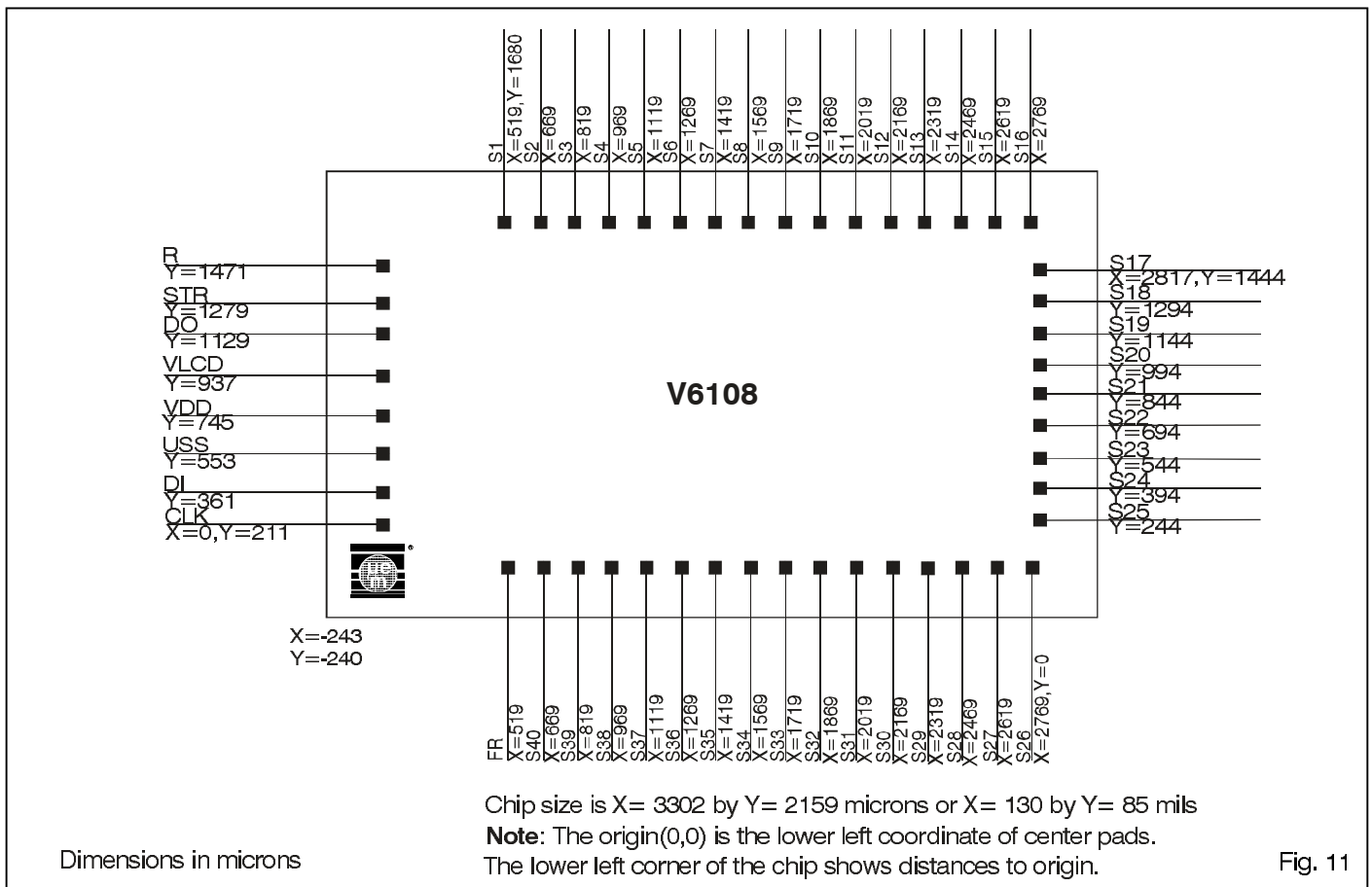
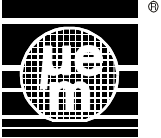

Fig. 10

## Package and Ordering Information

### Dimensions of Chip Form





## Side View and Recommended Solder Area

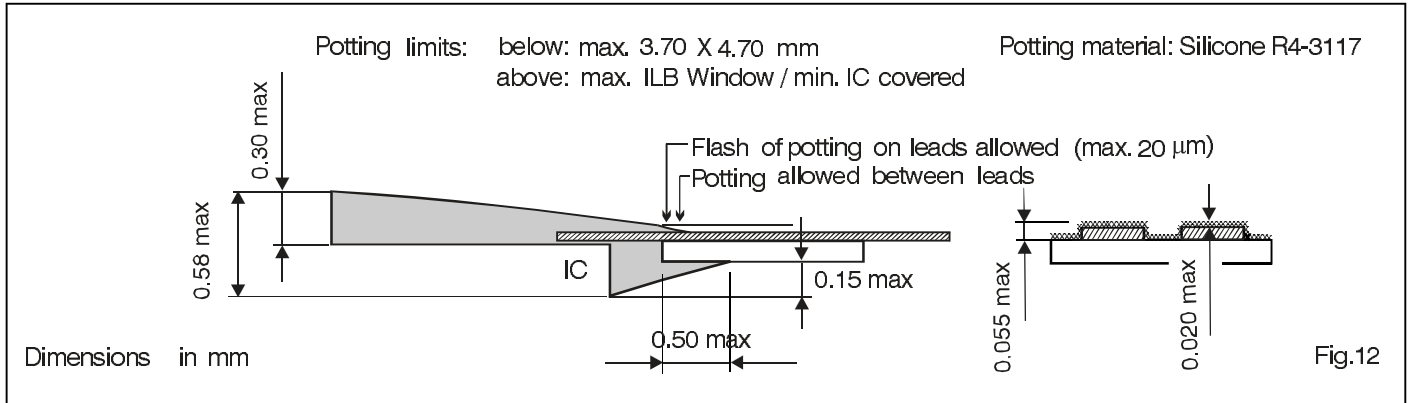

## Package and Ordering Information

The V 6108 is available in the following packages:

QFP52, pin plastic package	V6108 52F
TAB, tape automated bonding	V6108 TAB
Chip form	V6108 Chip *

When ordering, please specify the complete part number and package.

\* on request

EM Microelectronic-Marin SA cannot assume responsibility for use of any circuitry described other than circuitry entirely embodied in an EM Microelectronic-Marin product. EM Microelectronic-Marin reserves the right to change circuitry and specifications without notice at any time. You are strongly urged to ensure that the information given has not been superseded by a more up-to-date version.

© 1997 EM Microelectronic-Marin SA, 09/97, Rev. B/157