

TOSHIBA BiCMOS Integrated Circuit Silicon Monolithic

TB9000F

5 V Voltage Regulator with Watchdog Timer

The TB9000F is an IC specially designed for microcomputer systems in automobile. It features low standby current and various system reset functions.

With external pass Tr., TB9000F can supply high output current. As a protective function, current limiter function is incorporated.

The system reset includes low voltage reset/power on reset/watchdog timer.

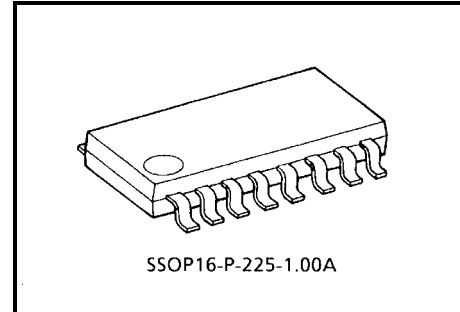

Weight: 0.14 g (typ.)

Features

- Accurate output: $5.0\text{ V} \pm 0.15\text{ V}$
- Low current consumption: $120\text{ }\mu\text{A}$ ($V_{\text{IN}} = 12\text{V}$, $T_a = 25^\circ\text{C}$) at 5 V Output + Reset timer
- Reset functions: Low voltage reset/Power on reset/Watchdog timer
- Current limiter: Adjustable with external resistor
- Operating temperature : -40 to 125°C
- Small SMD package: SSOP-16pin

Block Diagram & Pin Layout

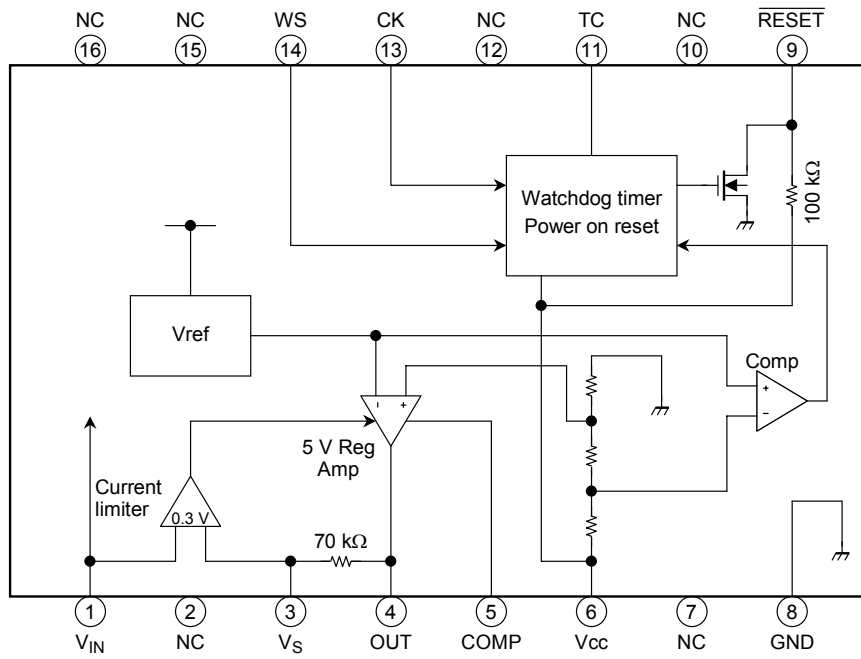

Note: Some of the functional blocks, circuits, or constants in the block diagram are omitted or simplified to clarify the descriptions of the relevant features.

Pin Description

Pin No.	Symbol	Description
1	V _{IN}	Power supply input pin. It contains current limiter and startup circuit.
3	V _S	Detection pin for the V _{CC} current limiter. A voltage drop occurring in the external resistor R _S between pins V _{IN} and V _S is monitored. The current limiter is actuated when the voltage drop exceeds 0.3 V. Ex.) When the current limiter need to be actuated at a load current of 600 mA R _S = 0.3 V/600 mA = 0.5 Ω
4	OUT	This pin is used to connect the base of an external PNP transistor. The output voltage is controlled by an internal op-amp to maintain it stably at 5 V. Since the recommended current of I _{OUT} is 8 mA, an output current of 600 mA can be flowed if H _{FE} of the external transistor is 80 or more.
5	COMP	Phase compensating pin for V _{CC} . Connect a phase compensating capacitor between pin V _{CC} and this pin.
6	V _{CC}	Voltage detection pin for the 5 V constant-voltage power supply, V _{CC} . It also supplies power to the reset timer circuit.
8	GND	Grounded
9	$\overline{\text{RESET}}$	Reset output pin for power on reset and watchdog timer. <ul style="list-style-type: none"> • Generates a reset signal which is determined by CT at the TC pin. • If no clock is fed to the CK input, this pin generates a reset pulse intermittently. This is an N-MOS drain output with a 100 kΩ pull-up resistor to V _{CC} .
11	TC	Time setup pin for the reset and watchdog timers. Connect capacitor CT to GND. The time is set up by internal constant current.
13	CK	Clock input pin for the watchdog timer. This pin detects rising edge of the input signal and does not require external coupling capacitor.
14	WS	Watchdog timer function ON/OFF control pin. Set to "Low" for active mode and "High" for inactive mode.
2, 7, 10, 12, 15, 16	NC	Not connected. (Electrically, this pin is completely open.)

Functional Description

The TB9000F incorporates a constant-voltage 5 V power supply function to feed stable power to the CPU and the system reset and CPU monitor functions to ensure stable operation of the CPU, etc. These functions are explained below.

(1) Constant-voltage 5V power supply function

This constant-voltage function has the reference voltage V_{ref} in the IC that is insusceptible to temperature changes and input voltage fluctuations. The power supply circuit is designed in such a way that this voltage is stepped up to 5 V by using an OP amp and a voltage-dividing resistor. These OP amp and dividing resistor and an output transistor connected to the OP amp output together configure a closed loop.

An overcurrent protection function is incorporated as a protective measure in case a fault such as shorting to GND occurs in the 5 V output. A current detecting resistor is inserted between the V_{IN} and the V_S pins, and a voltage drop across this resistor is detected by a comparator, thereby suppressing the operation of the OP amp to ensure that the voltage drop will not exceed 0.3 V. In this way, a current limiter function is actuated to prevent no more current from flowing.

(2) System reset function (See Timing Chart)

- **Voltage monitoring function**

When powered on, the power-on reset timer starts counting the moment the voltage V_{CC} applied to the CPU exceeds 4.7 V. When powered off, this voltage monitoring function outputs a reset signal immediately when V_{CC} drops below 4.7 V. A reset signal also is output immediately when V_{CC} drops for some reason during normal operation. Then, when V_{CC} is restored to the normal voltage and exceeds 4.7 V, the power-on reset timer starts counting.

The reset signal is output from the \overline{RESET} pin.

- **Power-on reset timer function**

To allow the 5 V constant voltage to stabilize at power-on, as well as provide a sufficient time for the clock oscillation in the CPU to stabilize, the device remains reset for a predetermined time before being released from the reset state. The duration of this time can be set as desired by choosing appropriate values for the external capacitor connected to the TC pin.

The system starts charging the capacitor when the V_{CC} voltage exceeds 4.7 V. When this charge voltage exceeds 4 V, the capacitor is discharged by the IC's internal transistor. When the capacitor is discharged down to 2 V, the reset signal is inverted to deactivate the reset.

- **Watchdog timer function**

Program your system to output a clock each time one program routine is finished in the CPU system software, and input this clock to the CK pin of the IC. The IC's TC pin is repeatedly charged and discharged between 2 V and 4 V. However, when a clock is input, it switches over and starts discharging in the middle of charging and then starts charging from 2 V again. Since the clock is generated at predetermined intervals when the CPU system is operating normally, the TC pin switches over and starts discharging before the charge voltage reaches 4 V. However, if no clock is input while being charged from 2 V to 4 V, the clock is assumed to have stopped, i.e., the CPU system has gone wild, so that a reset signal is output to reset the CPU system.

- **Watchdog timer stop function**

The watchdog timer can be switched ON or OFF by WS pin. If WS pin is fixed to low, the watchdog timer will be active. (TIMING CHART 1) If WS pin is fixed to high, the watchdog timer will be inactive. (TIMING CHART 2) When the WS pin is fixed to high, no reset signal is output, in which case only the power-on reset timer is useful.

Note: The overcurrent protection feature is only intended to protect the IC from a temporary short circuit. A short circuit over an extended period of time may place excessive stress on the IC, possibly causing it to be damaged. The system must be configured so that any overcurrent condition will be eliminated as soon as possible.

Timing Chart 1

WS = Low

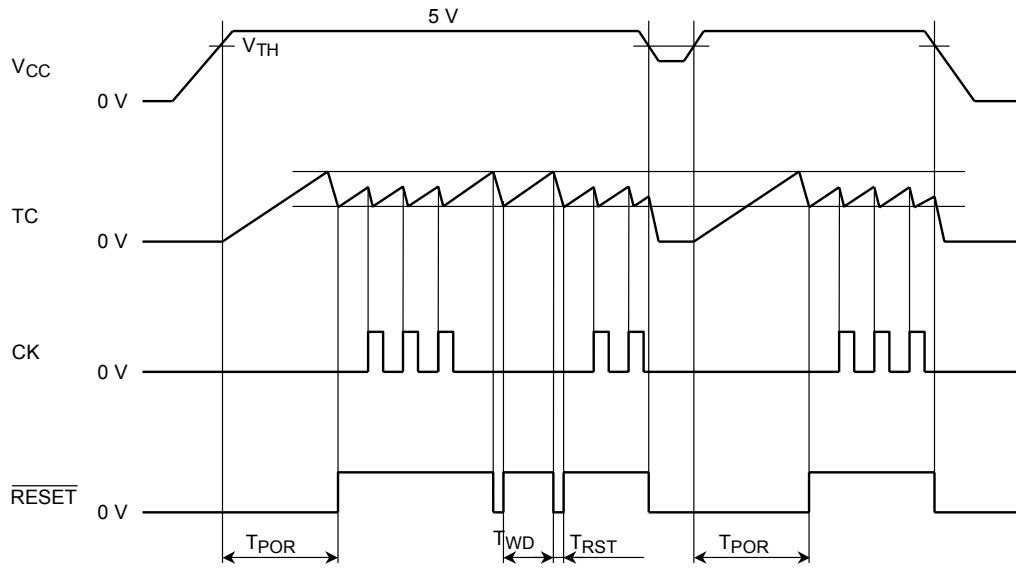

Timing Chart 2

WS = High

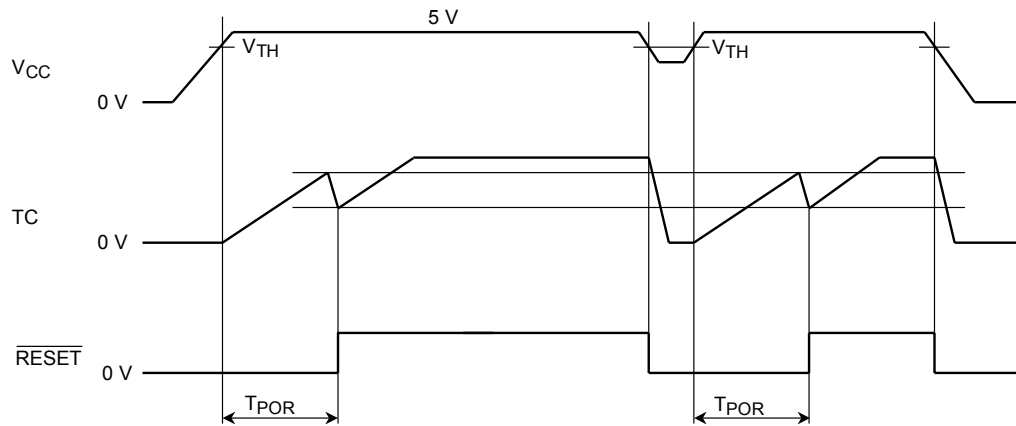

Note: Timing charts may be simplified to clarify the descriptions of features and operations.

Maximum Rating (Ta = 25°C)

Characteristics	Symbol	Rating	Unit
Input voltage	V _{IN}	45 (1 s)	V
	COMP, V _{CC} , RESET, CK, WS, TC	6.0	V
Output current	I _{OUT}	10	mA
Operating temperature	T _{opr}	-40 to 125	°C
Storage temperature	T _{stg}	-55 to 150	°C
Lead temperature-time	T _{sol}	240 (10 s)	°C

SSOP16-P-225 Thermal Resistance Data (Ta = 25°C)

Characteristics	Rating	Unit	Test Condition
R _{θj-a}	200	°C/W	Without radiation board
PD1	0.6	W	Without radiation board
PD2	0.78	W	50 × 50 × 1.6 mm 30% Cu board mounted

Note: The absolute maximum ratings of a semiconductor device are a set of specified parameter values which must not be exceeded during operation, even for an instant. If any of these levels is exceeded during operation, the device's electrical characteristics may be irreparably altered and the reliability and lifetime of the device can no longer be guaranteed, possibly causing damage to any other equipment with which it is used. Applications using the device should be designed such that the maximum ratings will never be exceeded in any operating conditions. Ensuring that the parameter values remain within these specified ranges during device operation will help to ensure that the integrity of the device is not compromised.

Electrical Characteristics ($V_{IN} = 6$ to 16 V, $I_{LOAD} = 10$ mA, $T_a = -40$ to 125°C)

Characteristics	Symbol	Pin	Test Circuit	Test Condition	Min	Typ.	Max	Unit
Output voltage	VREG	V _{CC}	—	Ta = -40 to 105°C	4.85	5.0	5.15	V
				Ta = -40 to 125°C	4.82	5.0	5.15	
Line regulation	VLINE	V _{CC}	—	V _{IN} = 6 to 40 V	—	0.1	0.5	%
Load regulation	VLOAD	V _{CC}	—	I _{LOAD} = 1 to 300 mA	—	0.2	1.0	%
Temperature coefficient	—	V _{CC}	—		—	0.01	—	%/°C
Output voltage	VOL	$\overline{\text{RESET}}$	—	I _{OL} = 2 mA	—	—	0.3	V
Output leakage current	I _{LEAK}	$\overline{\text{RESET}}$	—	V _{IN} ($\overline{\text{RESET}}$) = V _{CC}	—	—	5	μA
Input current	I _{IN}	TC	—	V _{IN} (TC) = GND	—	-10	—	μA
Input current	I _{IN}	CK	—	V _{IN} (CK) = 0 to V _{CC}	-5	—	5	μA
Input current	I _{IN}	WS	—	V _{IN} (WS) = 0 to V _{CC}	-5	—	5	μA
Input voltage	V _{IH}	CK	—		0.8 V _{CC}	—	—	V
	V _{IL}				—	—	0.2 V _{CC}	
Input voltage	V _{IH}	WS	—		0.8 V _{CC}	—	—	V
	V _{IL}				—	—	0.2 V _{CC}	
Current limiter detection	VLIMIT	V _{CC}	—		0.225	0.3	0.375	V
Current consumption	I _{CC}	—	—	Ta = 25°C, V _{IN} = 12 V	—	120	170	μA
				Ta = -40 to 125°C V _{IN} = 12 V	—	120	190	
Reset detection voltage	V _{TH}	V _{CC}	—		4.5	4.7	4.9	V
	ΔV _{TH}				V _{CC} - V _{TH}	0.25	0.30	
Power on reset	TPOR	$\overline{\text{RESET}}$	—		280 × CT	400 × CT	520 × CT	ms
Watchdog timer	TWD	$\overline{\text{RESET}}$	—		140 × CT	200 × CT	260 × CT	
Reset timer	TRST	$\overline{\text{RESET}}$	—		4.0 × CT	8.0 × CT	12.0 × CT	
Clock pulse width	Tw	CK	—		3	—	—	μs

Note1: CT is measured in unit of μF.

Note2: The specification values of power-on reset, watchdog timer and reset timer above are intended

to guarantee the IC itself. Note that the fluctuations of CT value should be taken into consideration

for practical use of the IC.

Note3: The specification of "Current consumption" is specified that I_{LOAD}=0mA.

Recommended Conditions

Part Name	Min	Typ.	Max	Unit
CT	0.01	0.25	10	μF

Reference Characteristics

Input – Output characteristics

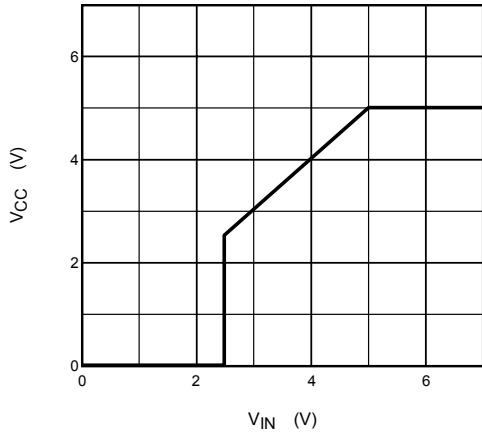

RESET output characteristics

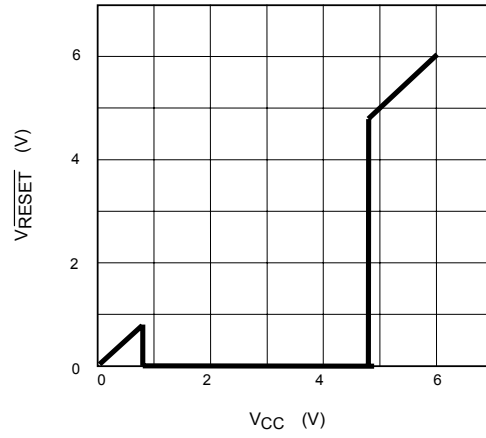

Current Limiter Characteristics

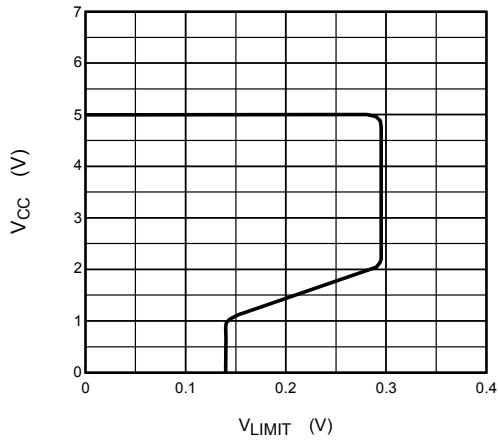

Example of Application Circuit

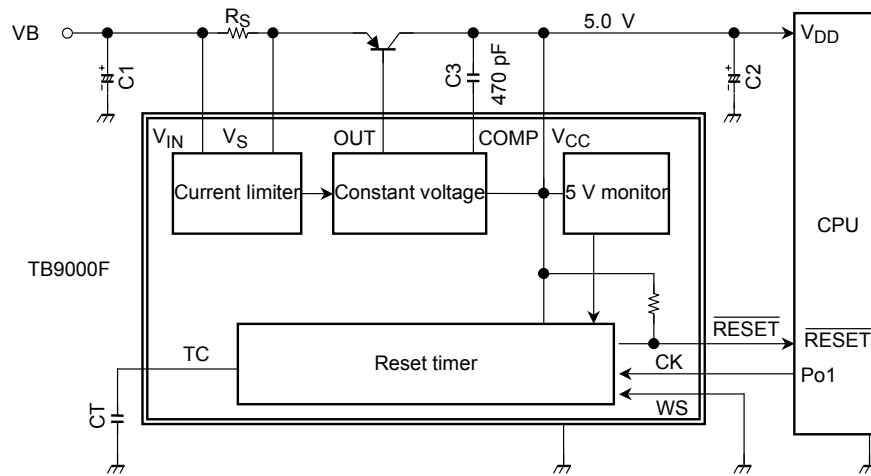

Caution for Wiring

- Note 1: C1 and C2 are for absorbing disturbances, noise, etc. C3 is for phase compensation.
- Note 2: Connect each capacitor as close to the IC as possible.
- Note 3: Ensure that the IC is mounted correctly. Failing to do so may result in the IC or target equipment being damaged.
- Note 4: The application circuit shown above is not intended to guarantee mass production. A thorough evaluation is required when designing an application circuit for mass production.

Package Dimensions

SSOP16-P-225-1.00A

Unit : mm

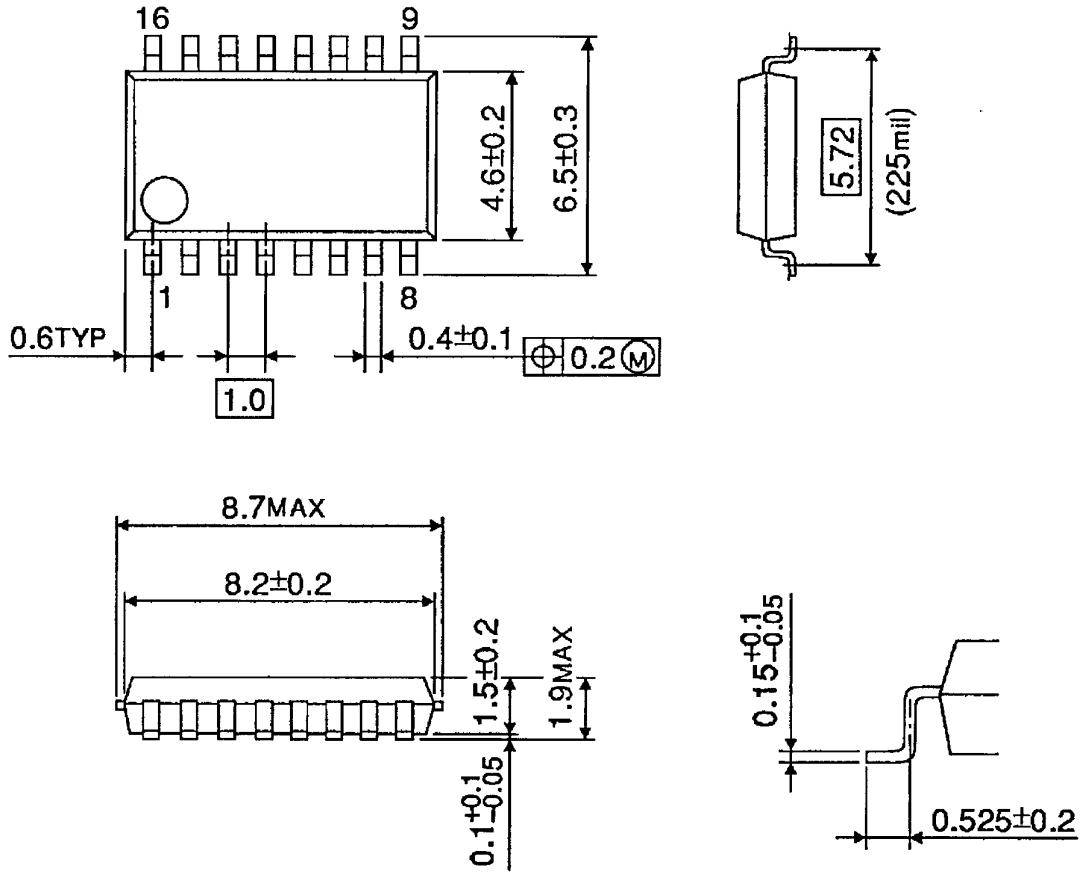

Weight: 0.14 g (typ.)

RESTRICTIONS ON PRODUCT USE

030619EBA

- The information contained herein is subject to change without notice.
- The information contained herein is presented only as a guide for the applications of our products. No responsibility is assumed by TOSHIBA for any infringements of patents or other rights of the third parties which may result from its use. No license is granted by implication or otherwise under any patent or patent rights of TOSHIBA or others.
- TOSHIBA is continually working to improve the quality and reliability of its products. Nevertheless, semiconductor devices in general can malfunction or fail due to their inherent electrical sensitivity and vulnerability to physical stress. It is the responsibility of the buyer, when utilizing TOSHIBA products, to comply with the standards of safety in making a safe design for the entire system, and to avoid situations in which a malfunction or failure of such TOSHIBA products could cause loss of human life, bodily injury or damage to property.
In developing your designs, please ensure that TOSHIBA products are used within specified operating ranges as set forth in the most recent TOSHIBA products specifications. Also, please keep in mind the precautions and conditions set forth in the "Handling Guide for Semiconductor Devices," or "TOSHIBA Semiconductor Reliability Handbook" etc..
- The TOSHIBA products listed in this document are intended for usage in general electronics applications (computer, personal equipment, office equipment, measuring equipment, industrial robotics, domestic appliances, etc.). These TOSHIBA products are neither intended nor warranted for usage in equipment that requires extraordinarily high quality and/or reliability or a malfunction or failure of which may cause loss of human life or bodily injury ("Unintended Usage"). Unintended Usage include atomic energy control instruments, airplane or spaceship instruments, transportation instruments, traffic signal instruments, combustion control instruments, medical instruments, all types of safety devices, etc.. Unintended Usage of TOSHIBA products listed in this document shall be made at the customer's own risk.
- The products described in this document are subject to the foreign exchange and foreign trade laws.
- TOSHIBA products should not be embedded to the downstream products which are prohibited to be produced and sold, under any law and regulations.