

Tiny Predictive Fan Failure Detector

Features

- Fan Wear-out Detection for 2-Wire Linear Controlled Fans
- Replacement System for 3-Wire Fans
- Fan Alert Signal when Fan Speed is below Programmed Threshold
- CLEAR Capability for Eliminating False Alarm
- Low Operating Current, 90 μ A (typ.)
- V_{DD} Range 3.0V to 5.5V
- Available in a 6-Pin SOT-23 Package

Applications

- Protection for Linear Controlled Fans
- Power Supplies
- Industrial Equipment
- PCs and Notebooks
- Data Storage
- Data Communications Equipment
- Instrumentation

Device Selection Table

Part Number	Package	Temp. Range
TC670ECH	6-Pin SOT-23	-40°C to +85°C

Package Type

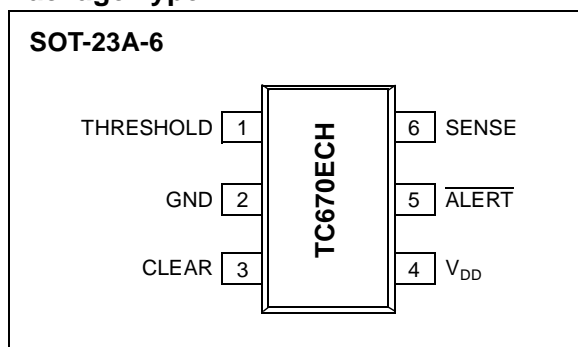

General Description

The TC670 is an integrated fan speed sensor that predicts and/or detects fan failure, preventing thermal damage to systems with cooling fans. When the fan speed falls below a user specified level, the TC670 asserts an $\overline{\text{ALERT}}$ signal. With this design, a critical minimum fan speed is determined by the user. The fan alert level is then set with a resistor divider on the THRESHOLD pin (Pin 1) of the TC670. When the minimum fan speed is reached, the $\overline{\text{ALERT}}$ pin (Pin 5) changes from a digital HIGH to LOW. This failure detection works with all linear controlled 2-wire fans. The TC670 eliminates the need for 3-wire fan solutions.

A CLEAR option can be used to reset the $\overline{\text{ALERT}}$ signal, allowing the flexibility of connecting the $\overline{\text{ALERT}}$ output of the TC670 with other Alert/FAULT interrupts in the system. This feature can be implemented so that false Fan Fault conditions do not initiate system shutdown.

The TC670 is specified to operate over the full industrial temperature range of -40°C to +85°C. The TC670 is offered in a SOT23-6 pin package and consumes 90 μ A (typ) during operation. The space saving package and low power consumption make this device an ideal choice for systems requiring fan speed monitoring.

Typical Application Circuit

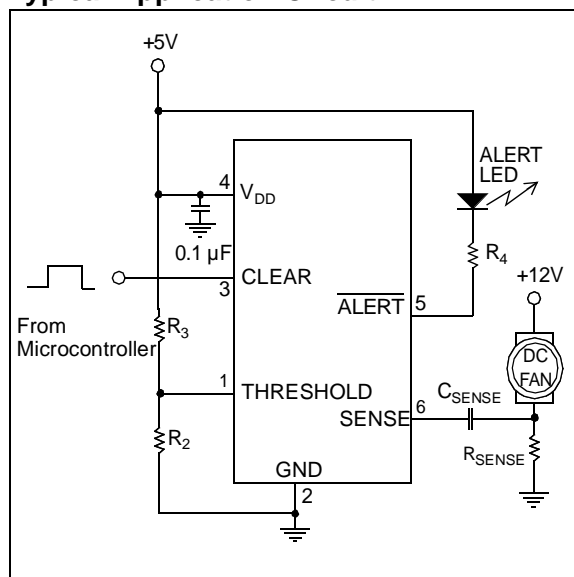

TC670

1.0 ELECTRICAL CHARACTERISTICS

Absolute Maximum Ratings*

V_{DD}	6.0V
All inputs and outputs w.r.t.	(GND – 0.3V) to (V_{DD} + 0.3V)
Difference Input voltage	IV_{DD} - GND
Output Short Circuit Current	continuous
Current at Input Pin	+/-2 mA
Current at Output Pin	+/-25 mA
Junction Temperature, T_J	150°C
ESD protection on all pins.....	≥ 4 kV
Operating Temperature Range.....	-40°C to +85°C
Storage Temperature Range	-55°C to +150°C

Stresses above those listed under “Absolute Maximum Ratings” may cause permanent damage to the device. These are stress ratings only and functional operation of the device at these or any other conditions above those indicated in the operation sections of the specifications is not implied. Exposure to Absolute Maximum Rating conditions for extended periods may affect device reliability.

TC670 ELECTRICAL SPECIFICATIONS

Electrical Characteristics: Unless otherwise specified, all limits are specified at +25°C, V_{DD} = 3.0V to 5.5V, CLEAR = Low. Boldface type specifications apply for temperature range of -40°C to +85°C						
Symbol	Parameters	Min	Typ	Max	Unit	Conditions
Power Supply:						
V_{DD}	Supply Voltage	3.0	—	5.5	V	
I_{DD}	Supply Current	—	90	150	μA	
CLEAR Input:						
V_{IH}	CLEAR Logic Input High Level	0.8 V_{DD}	—	—	V	
V_{IL}	CLEAR Logic Input Low Level	—	—	0.2 V_{DD}	V	
SENSE Input:						
$V_{TH(SENSE)}$	SENSE Input Level Threshold Voltage	—	124	—	mV	
R_{SENSE}	SENSE Input Resistance	—	50	—	kΩ	
THRESHOLD Input:						
	THRESHOLD Input Voltage Minimum	—	0.0	—	V	
	THRESHOLD Input Voltage Maximum	—	2.4	—	V	
	THRESHOLD Input Resistance	—	100	—	MΩ	
\overline{ALERT}_{ACC}	Programmed Fan Speed Alert Accuracy ⁽¹⁾	-10	—	+10	%	V_{DD} = 3.0V
ALERT Output:						
V_{LOW}	\overline{ALERT} Output Low Voltage	—	—	0.3	V	I_{SINK} = 2.5 mA
t_{DELAY}	\overline{ALERT} Output Delay Time	—	176	—	ms	

Note 1: The TC670 will operate properly over the entire power supply range of 3.0V to 5.5V. As V_{DD} varies from 3.0V, accuracy will degrade based on the percentage of V_{DD} as shown in Section 3.0.

TEMPERATURE SPECIFICATIONS

Electrical Characteristics: Unless otherwise specified, all limits are specified for -40°C to +85°C and V_{DD} = 3.0V to 5.5V						
Symbol	Parameters	Min	Typ	Max	Unit	Conditions
Temperature Ranges:						
T_A	Specified Temperature Range	-40	—	+85	°C	
T_A	Operating Temperature Range	-40	—	+85	°C	
Thermal Package Resistances:						
θ_{JA}	Thermal Resistance, 6L-SOT-23	—	230	—	°C/W	

2.0 PIN DESCRIPTIONS

The descriptions of the pins are listed in Table 2-1.

TABLE 2-1: PIN FUNCTION TABLE

Pin No. (6-Pin SOT-23)	Symbol	Description
1	THRESHOLD	Analog Input used to set Fan $\overline{\text{ALERT}}$ Threshold Voltage. Input range = 0.0V to 2.4V.
2	GND	Ground Terminal.
3	CLEAR	Digital Input. Active High. The $\overline{\text{ALERT}}$ Output is cleared when a high level signal is applied to this input.
4	VDD	Power Supply Input, 3.0V to 5.5V.
5	$\overline{\text{ALERT}}$	Digital (Open Drain) Output, active low. This pin goes low to indicate an alert condition when the fan speed at the SENSE pin reaches the alert threshold applied on the THRESHOLD pin.
6	SENSE	Analog Input. Current spikes are detected at this pin as the fan excitation signal transitions from high to low and low to high.

3.0 TYPICAL PERFORMANCE CHARACTERISTICS

Note: The graphs and tables provided following this note are a statistical summary based on a limited number of samples and are provided for informational purposes only. The performance characteristics listed herein are not tested or guaranteed. In some graphs or tables, the data presented may be outside the specified operating range (e.g., outside specified power supply range) and therefore outside the warranted range.

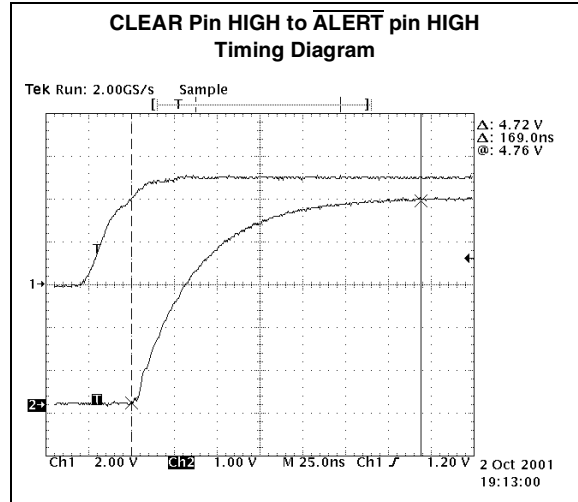
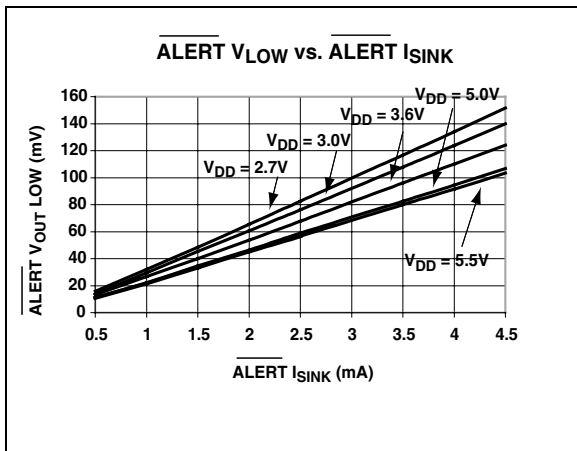
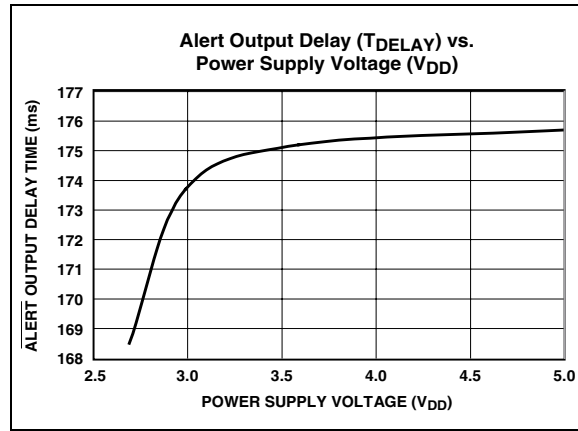
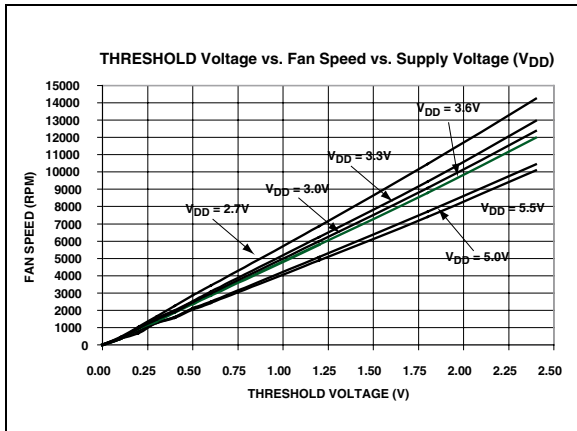
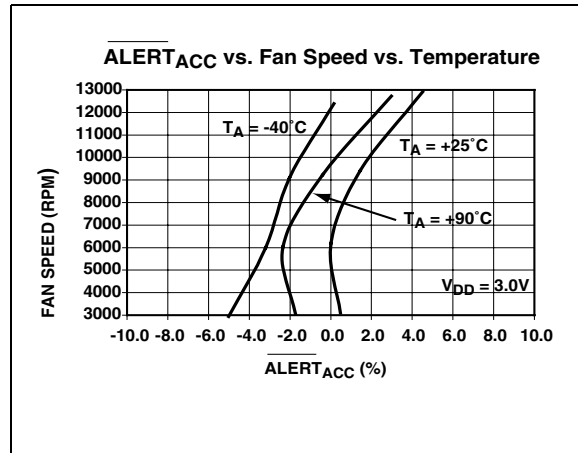
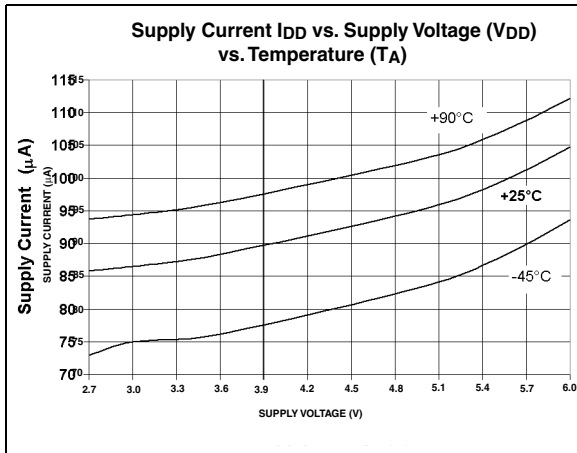

4.0 DETAILED DESCRIPTION

The TC670 is an integrated fan speed sensor that predicts/detects fan failure, consequently preventing thermal damage to systems with cooling fans. When the fan speed falls below a user programmed threshold level, the TC670 asserts an $\overline{\text{ALERT}}$ signal. This threshold is set with an external resistor divider network.

FIGURE 4-1: TC670 BLOCK DIAGRAM

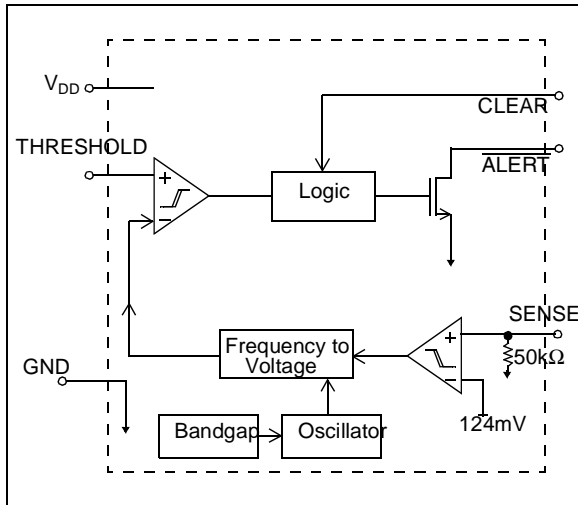

As shown in Figure 4-1, the TC670 senses the fan pulses and internally converts those pulses from a frequency into an analog voltage. This voltage is then compared with a DC voltage present on the THRESHOLD pin. If the converted frequency-to-voltage value from the fan's pulses falls below the THRESHOLD voltage, a FAULT signal is asserted through the $\overline{\text{ALERT}}$ pin (active LOW).

In a 3.0V system, the external fan alert level on the THRESHOLD pin can be designed from 0.0V (stalled fan) and up to 2.4V (for 13,000 RPM) to cover most of the common fan speeds. This failure detection system works with linear controlled 2-wire fans and eliminates the need for 3-wire fans. The TC670 can work with 3-wire fans as well either by using the SENSE circuit or by directly sensing the RPM output from the 3rd wire.

A CLEAR pin is provided to allow the user to reset the ALERT pin status back to a HIGH state. This CLEAR option also allows the flexibility of connecting the ALERT output of the TC670 with other Alert/FAULT interrupts in the system without having a risk of a system shutdown due to false Fan Fault condition.

FIGURE 4-2: TYPICAL APPLICATION CIRCUIT

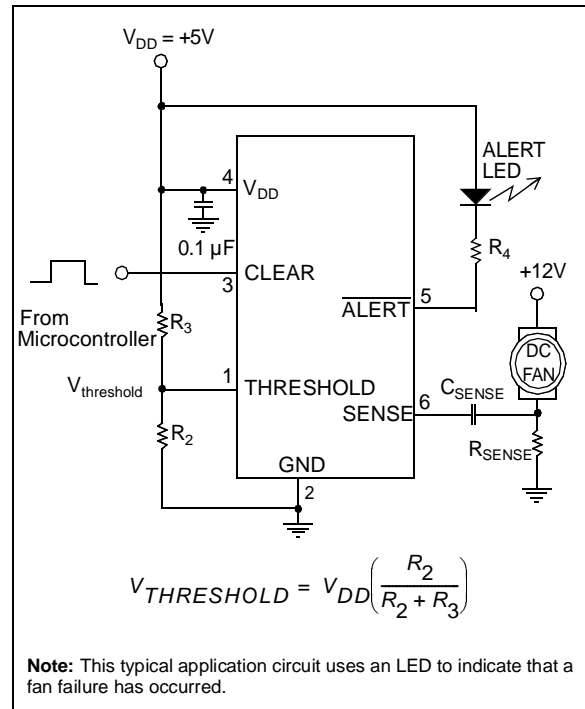

4.1 SENSE Input

As shown in Figure 4-2, the SENSE input (Pin 6) is connected through a sensing capacitor (C_{SENSE}). A low value current sensing resistor (R_{SENSE}) is also connected to the low side of the fan to the ground return leg of the fan. During normal fan operation, commutation occurs as each pole of the fan is energized. This causes brief interruptions in the fan current, seen as pulses across the sense resistor.

These short rapid changes in fan current cause a corresponding dV/dt voltage across the sense resistor as well as a corresponding dI/dt current across the sense capacitor. The current across C_{SENSE} is terminated with the internal 50k Ω input resistance at the SENSE pin of the TC670. When positive going fan pulses at the SENSE input are greater than 124mV (typ) the TC670 latches in those voltage spikes. This 124mV (typ) SENSE input built-in threshold reduces false triggering errors caused by extraneous noise pulses associated with a running fan. The presence and frequency of these pulses is a direct indication of fan operation and fan speed.

The design of the proper input SENSE circuitry is a matter of scaling R_{SENSE} to provide the necessary amount of gain and proper selection of the sensing capacitor. The following table (Table 4-1) lists some recommended values for R_{SENSE} according to the nominal operating current of the fan. Please note that the current draw specified by the fan manufacturer may not be the fan's nominal operating current, but a worst-case rating. If the fan current falls between two of the values listed, it is recommended that the higher value resistor is used.

TABLE 4-1: RECOMMENDED VALUES FOR R_{SENSE} PER FIGURE 4-2

Nominal Fan Current (mA)	R_{SENSE} (Ω)
100	4.7
200	2.4
300	1.8
400	1.3
500	1.0
600	0.8

A 0.1 μ F ceramic capacitor is recommended for C_{SENSE} . Smaller capacitor values will require larger sense resistors whereas larger capacitors are more expensive and occupy more board space.

4.2 THRESHOLD Input

The voltage at the THRESHOLD input sets the equivalent minimum allowable fan speed for the application. As shown in Section 3.0 typical performance curves, the relationship between the THRESHOLD voltage and minimum fan speed is also power supply and temperature dependant.

All the values for the THRESHOLD voltage that are shown in these graphs represent typical numbers and might not be optimized for all fans in all applications. To ensure accurate fan speed monitoring of a specific fan in a specific application, the user must perform a one-time correlation check with the prototype.

There are two techniques that can be used to calibrate the system. One approach is to find the fan's full scale capability and mathematically estimate the minimum acceptable speed of the fan. A second technique is to identify the fan's minimum speed and calibrate the THRESHOLD voltage accordingly.

4.2.1 THRESHOLD CALIBRATION USING FAN'S FULL SCALE SPEED

The fan should first be run at full speed. At full speed the $\overline{\text{THRESHOLD}}$ voltage level should be adjusted until the $\overline{\text{ALERT}}$ output is asserted. With this full scale value of the THRESHOLD voltage, the value can be scaled down to the Fan Fault speed as a percentage of the full speed. For example, if the fan full speed THRESHOLD voltage is 1.5V, then the Fan Fault THRESHOLD voltage at 30% of full speed would be 30% x 1.5V = 0.45V.

4.2.2 THRESHOLD CALIBRATION USING FAN'S MINIMUM ALLOWABLE SPEED ESTIMATE

For a more exact Fan Fault trip point, the user can run the fan at its minimum allowed speed. At this speed, the $\overline{\text{THRESHOLD}}$ voltage can be adjusted until the $\overline{\text{ALERT}}$ output is asserted.

4.3 CLEAR Input

The CLEAR input allows the user to reset the $\overline{\text{ALERT}}$ pin to a high status. This is an active HIGH input. Consequently, as long as CLEAR is HIGH, $\overline{\text{ALERT}}$ will always be HIGH as well. To allow $\overline{\text{ALERT}}$ to operate correctly CLEAR must be held LOW. This feature can be implemented so that false Fan Fault conditions do not initiate system shutdown.

4.4 $\overline{\text{ALERT}}$ Output

The $\overline{\text{ALERT}}$ output is an open drain output capable of sinking 2.5mA (typ). The $\overline{\text{ALERT}}$ output is asserted whenever the detected fan speed equals or falls below the equivalent voltage set at the THRESHOLD pin. The $\overline{\text{ALERT}}$ output is only deactivated once the CLEAR pin is brought to a HIGH state. Although the absolute maximum output current of this pin is 25mA, it is recommended that this current sinking into the $\overline{\text{ALERT}}$ Output does not exceed 20mA.

4.5 Power Supply Input, V_{DD}

To assure proper operation of the TC670 in a noisy environment where the fans are running, the V_{DD} pin (Pin 4) must be decoupled with a 0.1 μ F capacitor as shown in Figure 4-1. This capacitor should be located as close to the TC670 V_{DD} pin as possible as well being promptly terminated to the ground plane. A Ceramic capacitor is recommended.

4.6 Ground Terminal, GND

The GND pin (Pin 2) of the TC670 should be connected directly to the analog ground plane of the circuit board. Care should be taken in circuit layout to keep this pin away from switching signals, such as the fan excitation signals in order to avoid false signals on the SENSE pin.

5.0 PACKAGE INFORMATION

5.1 Package Marking Information

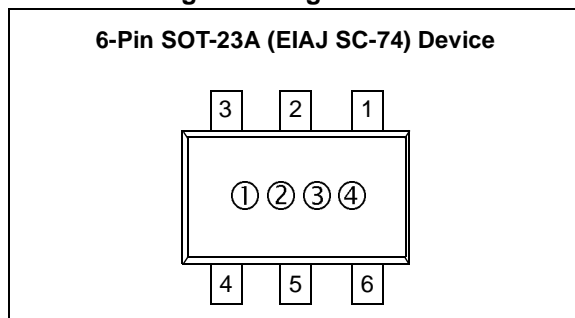

1 & 2 = part number code + temperature range and voltage

Part Number	Code
TC670ECH	

3 = year and quarter code

4 = lot ID number

TC670

5.2 Taping Form

Component Taping Orientation for 6-Pin SOT-23A (EIAJ SC-74) Devices

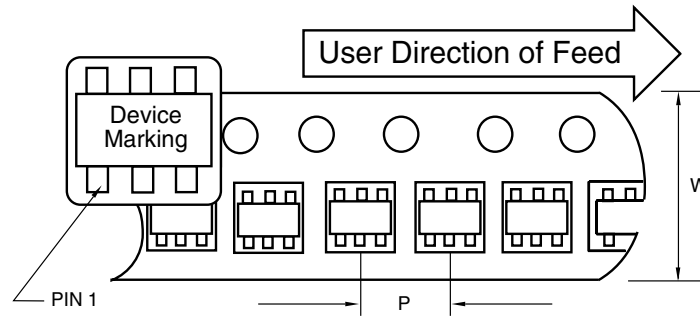

Standard Reel Component Orientation
For TR Suffix Device
(Mark Right Side Up)

Carrier Tape, Number of Components Per Reel and Reel Size

Package	Carrier Width (W)	Pitch (P)	Part Per Full Reel	Reel Size
6-Pin SOT-23A	8 mm	4 mm	3000	7 in

5.3 Package Dimensions

SOT-23A-6

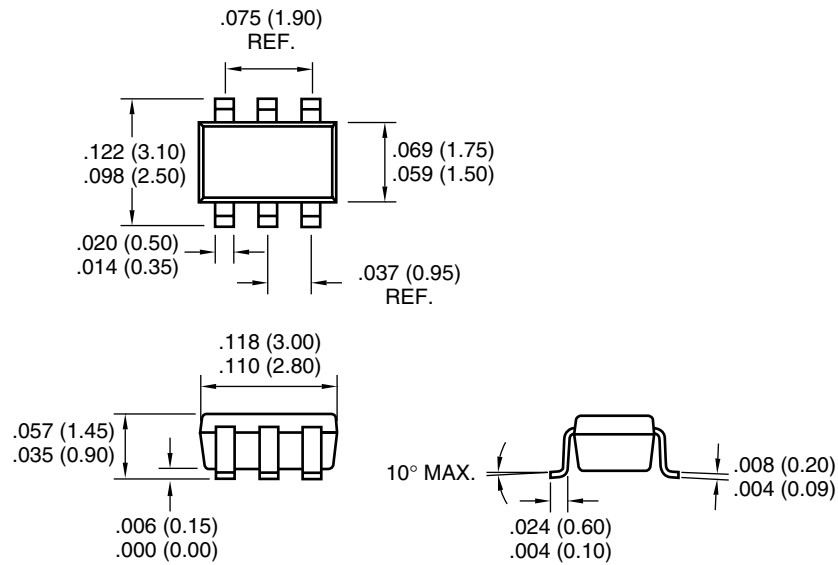

Dimensions: inches (mm)

SALES AND SUPPORT

Data Sheets

Products supported by a preliminary Data Sheet may have an errata sheet describing minor operational differences and recommended workarounds. To determine if an errata sheet exists for a particular device, please contact one of the following:

1. Your local Microchip sales office
2. The Microchip Corporate Literature Center U.S. FAX: (480) 792-7277
3. The Microchip Worldwide Site (www.microchip.com)

Please specify which device, revision of silicon and Data Sheet (include Literature #) you are using.

New Customer Notification System

Register on our web site (www.microchip.com/cn) to receive the most current information on our products.

TC670

NOTES:

Information contained in this publication regarding device applications and the like is intended through suggestion only and may be superseded by updates. It is your responsibility to ensure that your application meets with your specifications. No representation or warranty is given and no liability is assumed by Microchip Technology Incorporated with respect to the accuracy or use of such information, or infringement of patents or other intellectual property rights arising from such use or otherwise. Use of Microchip's products as critical components in life support systems is not authorized except with express written approval by Microchip. No licenses are conveyed, implicitly or otherwise, under any intellectual property rights.

Trademarks

The Microchip name and logo, the Microchip logo, FilterLab, KEELOQ, microID, MPLAB, PIC, PICmicro, PICMASTER, PICSTART, PRO MATE, SEEVAL and The Embedded Control Solutions Company are registered trademarks of Microchip Technology Incorporated in the U.S.A. and other countries.

dsPIC, ECONOMONITOR, FanSense, FlexROM, fuzzyLAB, In-Circuit Serial Programming, ICSP, ICEPIC, microPort, Migratable Memory, MPASM, MPLIB, MPLINK, MPSIM, MXDEV, PICC, PICDEM, PICDEM.net, rfPIC, Select Mode and Total Endurance are trademarks of Microchip Technology Incorporated in the U.S.A.

Serialized Quick Turn Programming (SQTP) is a service mark of Microchip Technology Incorporated in the U.S.A.

All other trademarks mentioned herein are property of their respective companies.

© 2002, Microchip Technology Incorporated, Printed in the U.S.A., All Rights Reserved.

 Printed on recycled paper.



Microchip received QS-9000 quality system certification for its worldwide headquarters, design and wafer fabrication facilities in Chandler and Tempe, Arizona in July 1999 and Mountain View, California in March 2002. The Company's quality system processes and procedures are QS-9000 compliant for its PICmicro® 8-bit MCUs, KEELOQ® code hopping devices, Serial EEPROMs, microperipherals, non-volatile memory and analog products. In addition, Microchip's quality system for the design and manufacture of development systems is ISO 9001 certified.



MICROCHIP

WORLDWIDE SALES AND SERVICE

AMERICAS

Corporate Office

2355 West Chandler Blvd.
Chandler, AZ 85224-6199
Tel: 480-792-7200 Fax: 480-792-7277
Technical Support: 480-792-7627
Web Address: <http://www.microchip.com>

Rocky Mountain

2355 West Chandler Blvd.
Chandler, AZ 85224-6199
Tel: 480-792-7966 Fax: 480-792-7456

Atlanta

500 Sugar Mill Road, Suite 200B
Atlanta, GA 30350
Tel: 770-640-0034 Fax: 770-640-0307

Boston

2 Lan Drive, Suite 120
Westford, MA 01886
Tel: 978-692-3848 Fax: 978-692-3821

Chicago

333 Pierce Road, Suite 180
Itasca, IL 60143
Tel: 630-285-0071 Fax: 630-285-0075

Dallas

4570 Westgrove Drive, Suite 160
Addison, TX 75001
Tel: 972-818-7423 Fax: 972-818-2924

Detroit

Tri-Atria Office Building
32255 Northwestern Highway, Suite 190
Farmington Hills, MI 48334
Tel: 248-538-2250 Fax: 248-538-2260

Kokomo

2767 S. Albright Road
Kokomo, Indiana 46902
Tel: 765-864-8360 Fax: 765-864-8387

Los Angeles

18201 Von Karman, Suite 1090
Irvine, CA 92612
Tel: 949-263-1888 Fax: 949-263-1338

New York

150 Motor Parkway, Suite 202
Hauppauge, NY 11788
Tel: 631-273-5305 Fax: 631-273-5335

San Jose

Microchip Technology Inc.
2107 North First Street, Suite 590
San Jose, CA 95131
Tel: 408-436-7950 Fax: 408-436-7955

Toronto

6285 Northam Drive, Suite 108
Mississauga, Ontario L4V 1X5, Canada
Tel: 905-673-0699 Fax: 905-673-6509

ASIA/PACIFIC

Australia

Microchip Technology Australia Pty Ltd
Suite 22, 41 Rawson Street
Epping 2121, NSW
Australia
Tel: 61-2-9868-6733 Fax: 61-2-9868-6755

China - Beijing

Microchip Technology Consulting (Shanghai)
Co., Ltd., Beijing Liaison Office
Unit 915
Bei Hai Wan Tai Bldg.
No. 6 Chaoyangmen Beidajie
Beijing, 100027, No. China
Tel: 86-10-85282100 Fax: 86-10-85282104

China - Chengdu

Microchip Technology Consulting (Shanghai)
Co., Ltd., Chengdu Liaison Office
Rm. 2401, 24th Floor,
Ming Xing Financial Tower
No. 88 TIDU Street
Chengdu 610016, China
Tel: 86-28-86766200 Fax: 86-28-86766599

China - Fuzhou

Microchip Technology Consulting (Shanghai)
Co., Ltd., Fuzhou Liaison Office
Unit 28F, World Trade Plaza
No. 71 Wusi Road
Fuzhou 350001, China
Tel: 86-591-7503506 Fax: 86-591-7503521

China - Shanghai

Microchip Technology Consulting (Shanghai)
Co., Ltd.
Room 701, Bldg. B
Far East International Plaza
No. 317 Xian Xia Road
Shanghai, 200051
Tel: 86-21-6275-5700 Fax: 86-21-6275-5060

China - Shenzhen

Microchip Technology Consulting (Shanghai)
Co., Ltd., Shenzhen Liaison Office
Rm. 1315, 13/F, Shenzhen Kerry Centre,
Renminnan Lu
Shenzhen 518001, China
Tel: 86-755-2350361 Fax: 86-755-2366086

China - Hong Kong SAR

Microchip Technology Hongkong Ltd.
Unit 901-6, Tower 2, Metroplaza
223 Hing Fong Road
Kwai Fong, N.T., Hong Kong
Tel: 852-2401-1200 Fax: 852-2401-3431

India

Microchip Technology Inc.
India Liaison Office
Divyasree Chambers
1 Floor, Wing A (A3/A4)
No. 11, O'Shaugnessey Road
Bangalore, 560 025, India
Tel: 91-80-2290061 Fax: 91-80-2290062

Japan

Microchip Technology Japan K.K.
Benex S-1 6F
3-18-20, Shinyokohama
Kohoku-Ku, Yokohama-shi
Kanagawa, 222-0033, Japan
Tel: 81-45-471-6166 Fax: 81-45-471-6122

Korea

Microchip Technology Korea
168-1, Youngbo Bldg. 3 Floor
Samsung-Dong, Kangnam-Ku
Seoul, Korea 135-882
Tel: 82-2-554-7200 Fax: 82-2-558-5934

Singapore

Microchip Technology Singapore Pte Ltd.
200 Middle Road
#07-02 Prime Centre
Singapore, 188980
Tel: 65-6334-8870 Fax: 65-6334-8850

Taiwan

Microchip Technology Taiwan
11F-3, No. 207
Tung Hua North Road
Taipei, 105, Taiwan
Tel: 886-2-2717-7175 Fax: 886-2-2545-0139

EUROPE

Denmark

Microchip Technology Nordic ApS
Regus Business Centre
Lautrup høj 1-3
Ballerup DK-2750 Denmark
Tel: 45 4420 9895 Fax: 45 4420 9910

France

Microchip Technology SARL
Parc d'Activite du Moulin de Massy
43 Rue du Saule Trapu
Batiment A - 1er Etage
91300 Massy, France
Tel: 33-1-69-53-63-20 Fax: 33-1-69-30-90-79

Germany

Microchip Technology GmbH
Gustav-Heinemann Ring 125
D-81739 Munich, Germany
Tel: 49-89-627-144 0 Fax: 49-89-627-144-44

Italy

Microchip Technology SRL
Centro Direzionale Colleoni
Palazzo Taurus 1 V. Le Colleoni 1
20041 Agrate Brianza
Milan, Italy
Tel: 39-039-65791-1 Fax: 39-039-6899883

United Kingdom

Microchip Ltd.
505 Eskdale Road
Winnersh Triangle
Wokingham
Berkshire, England RG41 5TU
Tel: 44 118 921 5869 Fax: 44-118 921-5820

04/20/02

