



Micro Commercial Components  
 21201 Itasca Street Chatsworth  
 CA 91311  
 Phone: (818) 701-4933  
 Fax: (818) 701-4939

## Features

- Fast Switching Speed
- Surface Mount Package Ideally Suited for Automatic Insertion
- For General Purpose Switching Applications
- High Conductance

## Mechanical Data

- Case: SOD-323, Molded Plastic
- Terminals: Solderable per MIL-STD-202, Method 208
- Polarity: Indicated by Cathode Band
- Weight: 0.008 grams ( approx.)

## Maximum Ratings @ 25°C Unless Otherwise Specified

Characteristic	Symbol	Value	Unit
Non-Repetitive Peak Reverse Volt.	$V_{RM}$	100	V
Peak Repetitive Reverse Voltage	$V_{RRM}$		
Working Peak Reverse Voltage	$V_{RWM}$	75	V
DC Blocking Voltage	$V_R$		
RMS Reverse Voltage	$V_{R(RMS)}$	53	V
Forward Continuous Current(Note1)	$I_{FM}$	300	mA
Average Rectified Output Current	$I_o$	150	mA
Non-Repetitive Peak @ $t \leq 1.0s$	$I_{FSM}$	2	A
Forward Surge Current @ $t = 10\mu s$		1	A
Power Dissipation(Note 1)	$P_d$	500	mW
Thermal Resistance(Note 1)	R	315	K/W
Operation/Storage Temp. Range	$T_j, T_{STG}$	-55 to +150	°C

## Electrical Characteristics @ 25°C Unless Otherwise Specified

Charateristic	Symbol	Max	Unit	Test Cond.
Maximum Forward Voltage Drop	$V_{FM}$	0.715	V	$I_F = 1.0mA$
		0.855		$I_F = 10mA$
		1		$I_F = 50mA$
		1.25		$I_F = 150mA$
Maximum Peak Reverse Current	$I_{RM}$	50	uA	$V_R = 20V, T_j = 150^\circ C$
		5		$V_R = 75V, T_j = 25^\circ C$
		25		$V_R = 20V$
Junction Capacitance	$C_j$	4	pF	$V_R = 0V, f = 1.0MHz$
Reverse Recovery Time	$t_{rr}$	4	ns	$I_F = I_R = 50mA, I_{rr} = 0.1I_R, R_L = 100 OHM$

**Note:** 1. Valid provided that terminals are kept at ambient temperature

# 1N4148WX

## High Speed Switching Diode 500mW

## SOD323

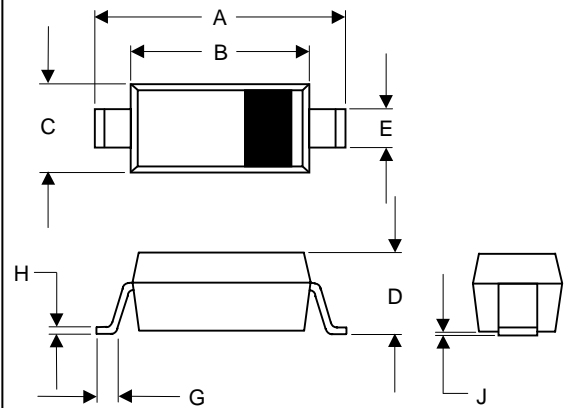

DIM	DIMENSIONS				NOTE
	INCHES		MM		
	MIN	MAX	MIN	MAX	
A	.090	.107	2.30	2.70	
B	.063	.071	1.60	1.80	
C	.045	.053	1.15	1.35	
D	.031	.045	0.80	1.15	
E	.010	.016	0.25	0.40	
G	.004	.018	0.10	0.45	
H	.004	.010	0.10	0.25	
J	-----	.006	-----	0.15	

### SUGGESTED SOLDER PAD LAYOUT

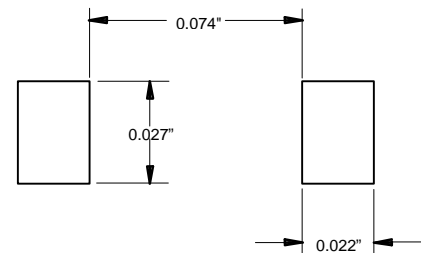

# 1N4148WX

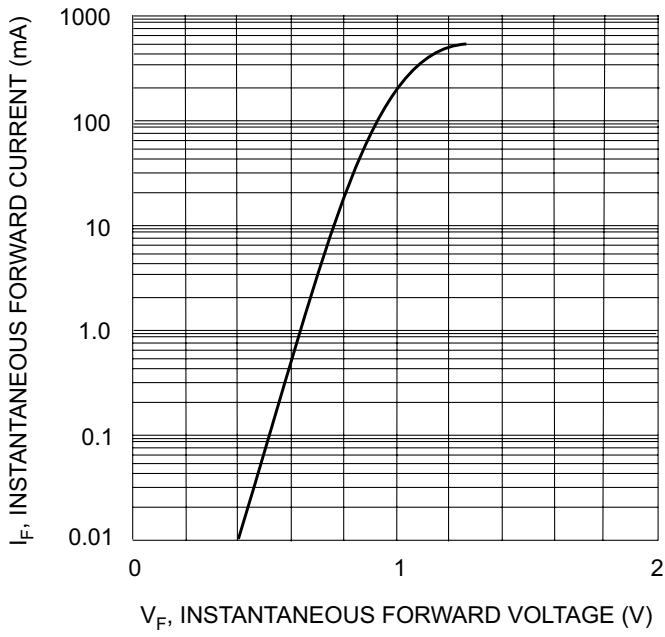

Fig. 1 Forward Characteristics

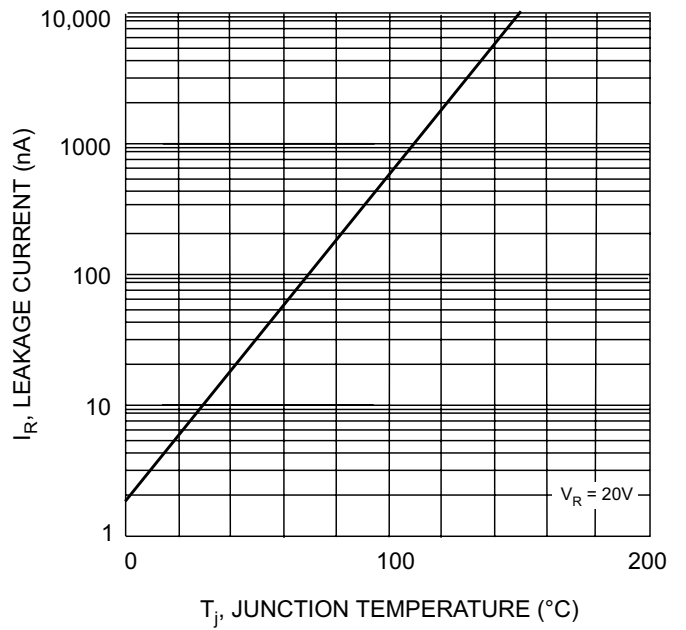

Fig. 2 Leakage Current vs Junction Temperature