

#### DUAL RECORD/PLAY PRE-AMPLIFIER

The KIA6268P is a dual preamplifier with ALC and muting designed for use in record/playback amplifier of tape recorder. It is suitable for a radio cassette tape recorder.

#### FEATURES

- Built-in ALC detector circuit.
- Built-in muting circuit.
- Operating supply voltage range :  $V_{CC}=6\sim 15V$ .

#### MAXIMUM RATINGS ( $T_a=25^\circ C$ )

CHARACTERISTIC	SYMBOL	RATING	UNIT
Supply Voltage	$V_{CC}$	16	V
Power Dissipation (Note)	$P_D$	750	mW
Operating Temperature	$T_{opr}$	$-25\sim 75$	$^\circ C$
Storage Temperature	$T_{stg}$	$-55\sim 150$	$^\circ C$

Note : Derated above  $T_a=25^\circ C$  in the proportion of  $6mW/^\circ C$  for KIA6268P

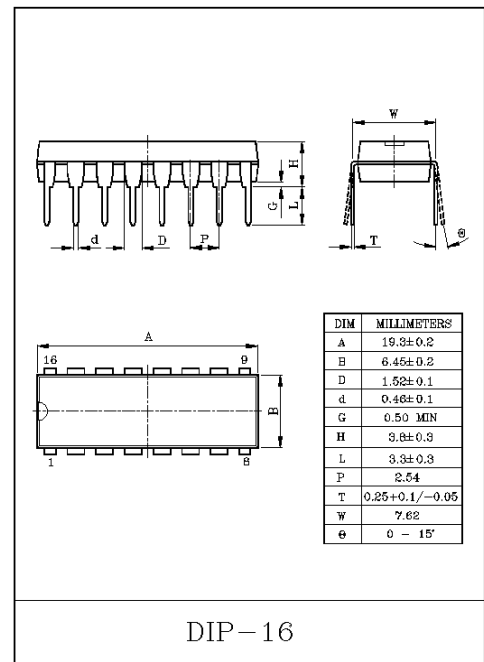

#### TYPICAL DC VOLTAGE OF EACH TERMINAL ( $V_{CC}=9V, T_a=25^\circ C$ , Terminal Voltage at No signal)

TERMINAL NO.	ITEM	SYMBOL	DC VOLTAGE	UNIT
Terminal 1	Rec. GND	$V_1$	0	V
2	$V_s$	$V_2$	8.2	V
3	Mute OUT	$V_3$	0	V
4	Rec. OUT	$V_4$	3.3	V
5	Pre. OUT & Rec. IN	$V_5$	1.3	V
6	Pre. IN NF	$V_6$	1.3	V
7	Pre. IN	$V_7$	0	V
8	ALC	$V_8$	0.9	V
9	Pre. GND	$V_9$	0	V
10	Pre. IN	$V_{10}$	0	V
11	Pre. IN NF	$V_{11}$	1.3	V
12	Pre OUT & Rec. IN	$V_{12}$	1.3	V
13	Rec. OUT	$V_{13}$	3.3	V
14	Mute OUT	$V_{14}$	0	V
15	Mute IN	$V_{15}$	2.4	V
16	$V_{CC}$	$V_{16}$	9.0	V

# KIA6268P

## BLOCK DIAGRAM & TEST CIRCUIT

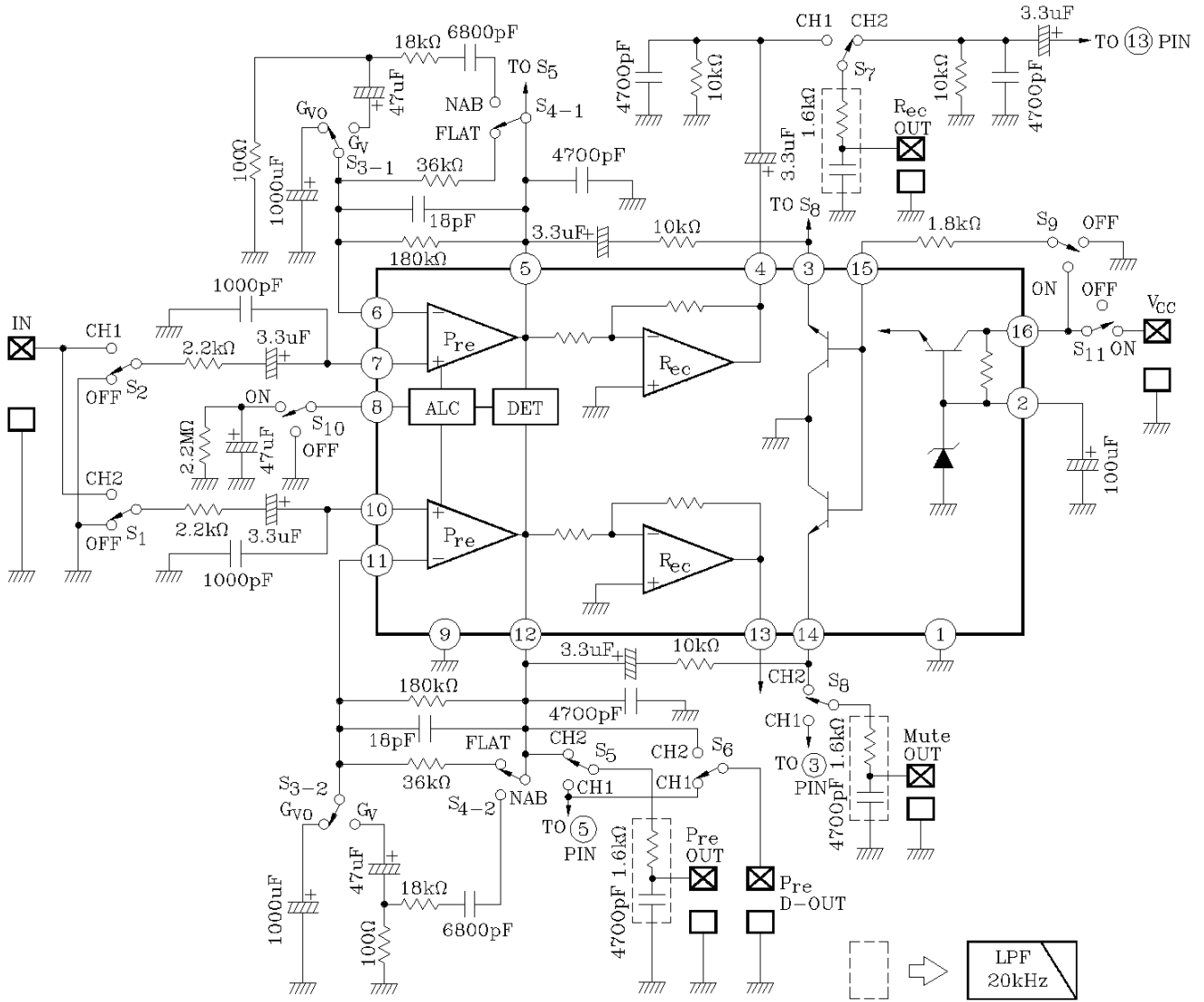

# KIA6268P

ELECTRICAL CHARACTERISTICS (Unless otherwise specified.  $V_{CC}=9V$ ,  $f=1kHz$ ,  $T_a=25^{\circ}C$ )

CHARACTERISTIC		SYMBOL	TEST CIRCUIT	TEST CONDITION	MIN.	TYP.	MAX.	UNIT
Quiescent Current		$I_{CCQ}$	1	$V_{IN}=0$	-	8.5	10.5	mA
PRE. AMP	Open Loop Voltage Gain	$G_{VO}$	1	$V_{IN}=-80dBm$	65	78	-	dB
	Max. Output Voltage	$V_{OM(1)}$	1	THD=1%	0.5	0.8	-	$V_{rms}$
	Total Harmonic Distortion	THD(1)	1	$V_O=0.2V_{rms}$	-	0.15	0.5	%
	Output Noise Voltage	$V_{NO}$	1	$R_g=2.2k\Omega$ , BW=20Hz~20kHz NAB EQ	-	0.26	0.6	$mV_{rms}$
	Cross Talk	C.T	1	$R_g=2.2k\Omega$ , $V_O=0dBm$	47	60	-	dB
REC. AMP	Closed Loop Voltage Gain	$G_V$	1	$R_L=10k\Omega$ , $V_O=0dBm$	12.7	14.7	16.7	dB
	Max. Output Voltage	$V_{OM(2)}$	1	THD=1%	2.0	2.5	-	$V_{rms}$
	Total Harmonic Distortion	THD(2)	1	$V_O=1.5V_{rms}$	-	0.2	-	%
	ALC Range (Note)	$R_{ALC}$	1	$V_{IN}=-60dBm$ , $R_{IN}=2.2k\Omega$	-	45	-	dB
	Total Harmonic Distortion (ALC)	THD(ALC)	1	$V_{IN}=-20dBm$ , $R_{IN}=2.2k\Omega$ , $R_L=10k\Omega$	-	0.3	1.0	%
	ALC Voltage	$V_O(ALC)$	1	$V_{IN}=-20dBm$ , $R_{IN}=2.2k\Omega$ , $R_L=10k\Omega$	0.9	1.1	1.42	$V_{rms}$
Muting Attenuation	ATT	1	-	45	55	-	dB	
ALC Balance	$B_{ALC}$	1	$V_{IN}=-20dBm$	-	0	2	dB	

Note : Input voltage range from  $V_{IN}=-60dBm$  to output voltage  $V_{OUT}$  3dB up.

# KIA6268P

## TEST METHOD

SYMBOL \ SW	S1	S2	S3	S4	S5	S6	S7	S8	S9	S10	MEASURE TERMINAL
I <sub>CCQ</sub>	※	※	※	※	※	※	※	※	OFF	※	V <sub>CC</sub>
G <sub>VO</sub>	OFF	CH1	G <sub>VO</sub>	FLAT	CH1	※	※	※	OFF	OFF	Pre OUT
V <sub>OM(1)</sub>	OFF	CH1	G <sub>V</sub>	NAB	CH1	※	※	※	OFF	OFF	Pre OUT
THD(1)	OFF	CH1	G <sub>V</sub>	NAB	CH1	※	※	※	OFF	OFF	Pre OUT
V <sub>NO</sub>	OFF	OFF	G <sub>V</sub>	NAB	CH2	CH1	※	※	OFF	OFF	Pre D-OUT
C.T.	OFF	CH1	G <sub>V</sub>	FLAT	CH1 →CH2	※	※	※	OFF	OFF	Pre OUT
G <sub>V</sub>	OFF	CH1	G <sub>V</sub>	FLAT	CH1	※	CH1	CH2	OFF	OFF	Pre OUT→Rec OUT
V <sub>OM(2)</sub>	OFF	CH1	G <sub>V</sub>	FLAT	CH2	※	CH1	CH2	OFF	OFF	Rec OUT
THD(2)	OFF	CH1	G <sub>V</sub>	FLAT	CH2	※	CH1	CH2	OFF	OFF	Rec OUT
R <sub>ALC</sub>	OFF	CH1	G <sub>V</sub>	FLAT	CH2	※	CH1	CH2	OFF	ON	Rec OUT
THD(ALC)	OFF	CH1	G <sub>V</sub>	FLAT	CH2	※	CH1	CH2	OFF	ON	Rec OUT
V <sub>O(ALC)</sub>	OFF	CH1	G <sub>V</sub>	FLAT	CH2	※	CH1	CH2	OFF	ON	Rec OUT
ATT	OFF	CH1	G <sub>V</sub>	FLAT	CH1	※	※	CH1	OFF →ON	OFF	Mute OUT
B <sub>ALC</sub>	CH2	CH1 →CH2	G <sub>V</sub>	FLAT	※	※	CH1 →CH2	※	OFF	ON	Rec OUT

※ : No specified.

# KIA6268P

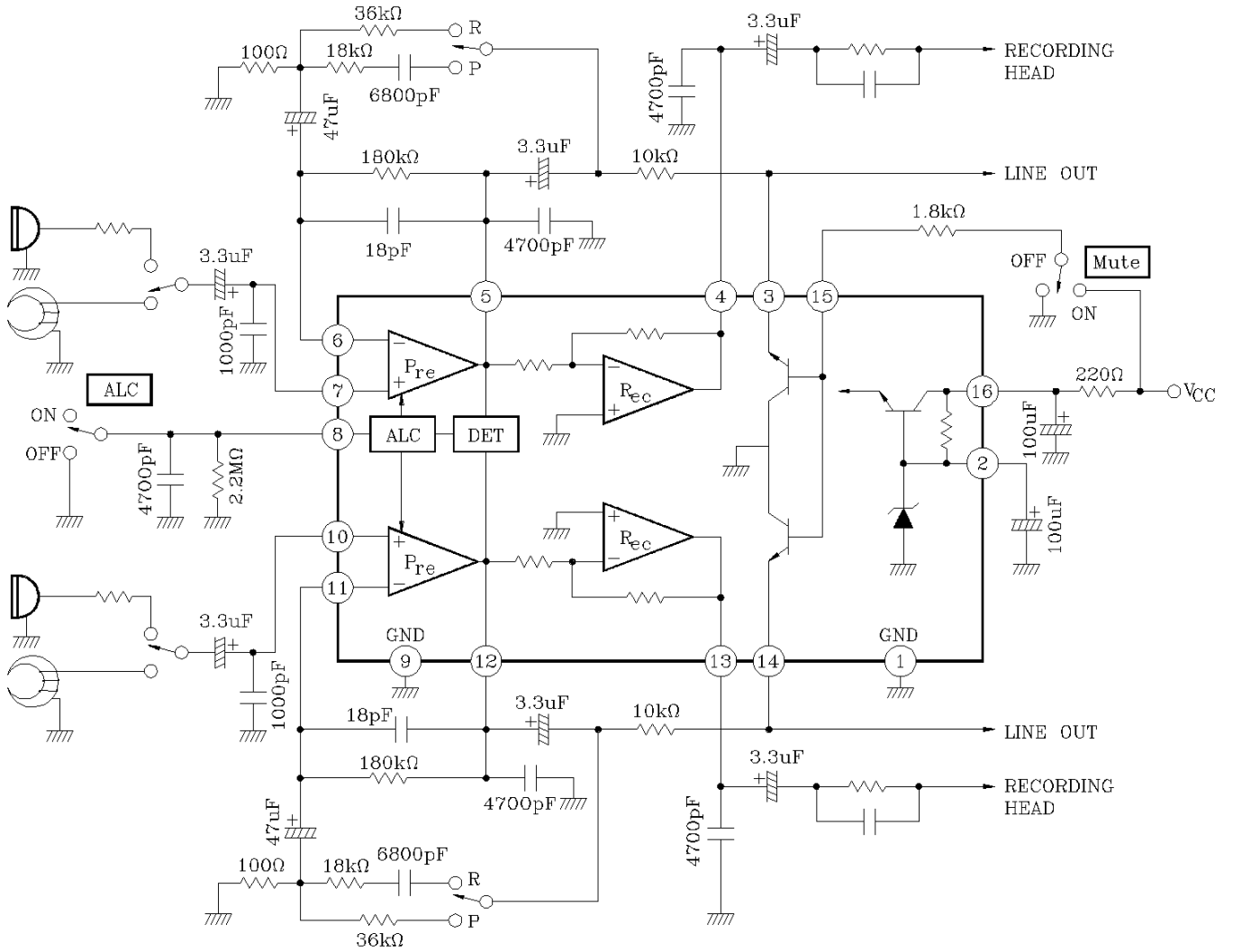

# KIA6268P

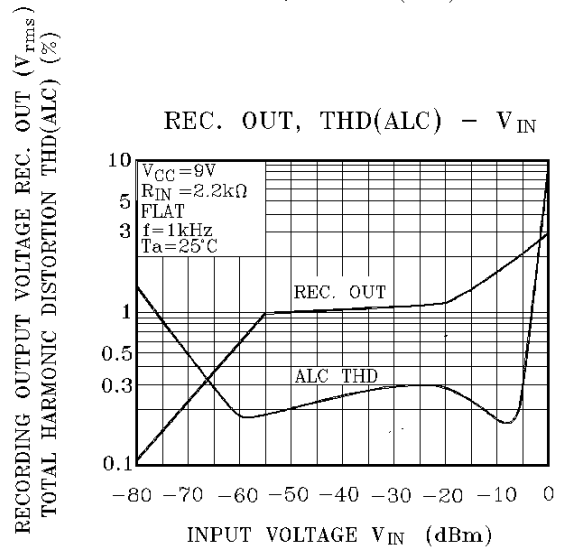
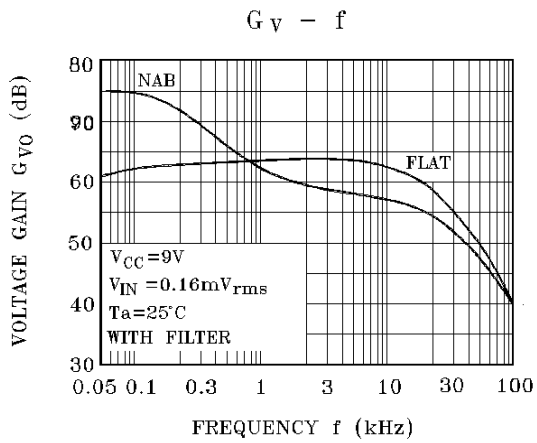
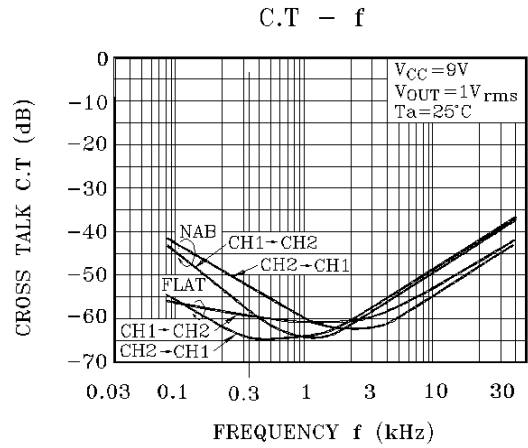
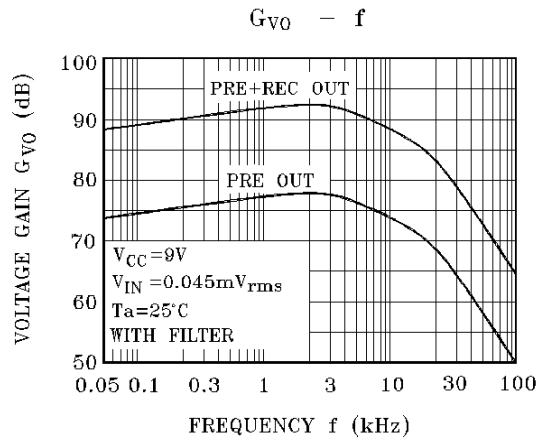

# KIA6268P

