

# MN657011H

## Low Power 8-Bit, 3-Channel CMOS D/A Converter for Image Processing

### ■ Overview

The MN657011H is an 8-bit, 3-channel CMOS digital-to-analog converter with a maximum conversion rate of 20 MSPS.

It is a 3.5 volt version of the MN65701FHP.

### ■ Features

- Maximum conversion rate: 20 MSPS (min.)
- Linearity error:  $\pm 0.2$  LSB (typ.)
- Differential linearity error:  $\pm 0.2$  LSB (typ.)
- Power supply voltage:  $3.5 \pm 0.1$  V
- Full scale current: 4 mA (typ.)
- Power consumption: 84 mW (typ.) ( $f_{CLK} = 15$  MHz)

### ■ Applications

- Digital television
- Digital video equipment
- Digital image processing equipment

### ■ Pin Assignment

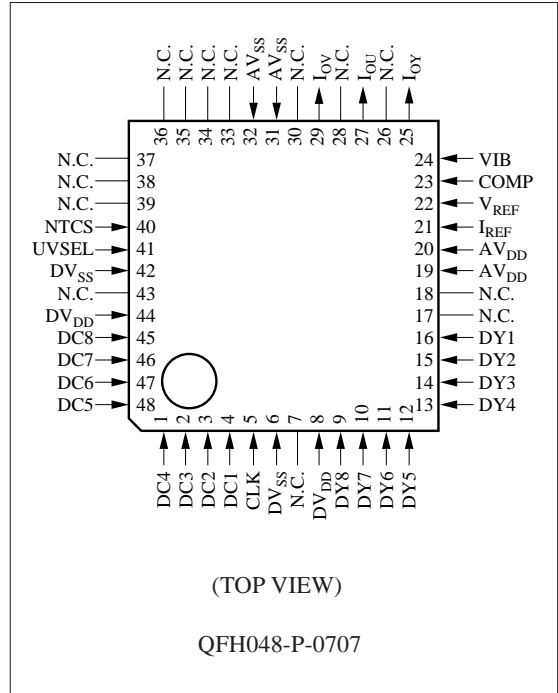

■ Block Diagram

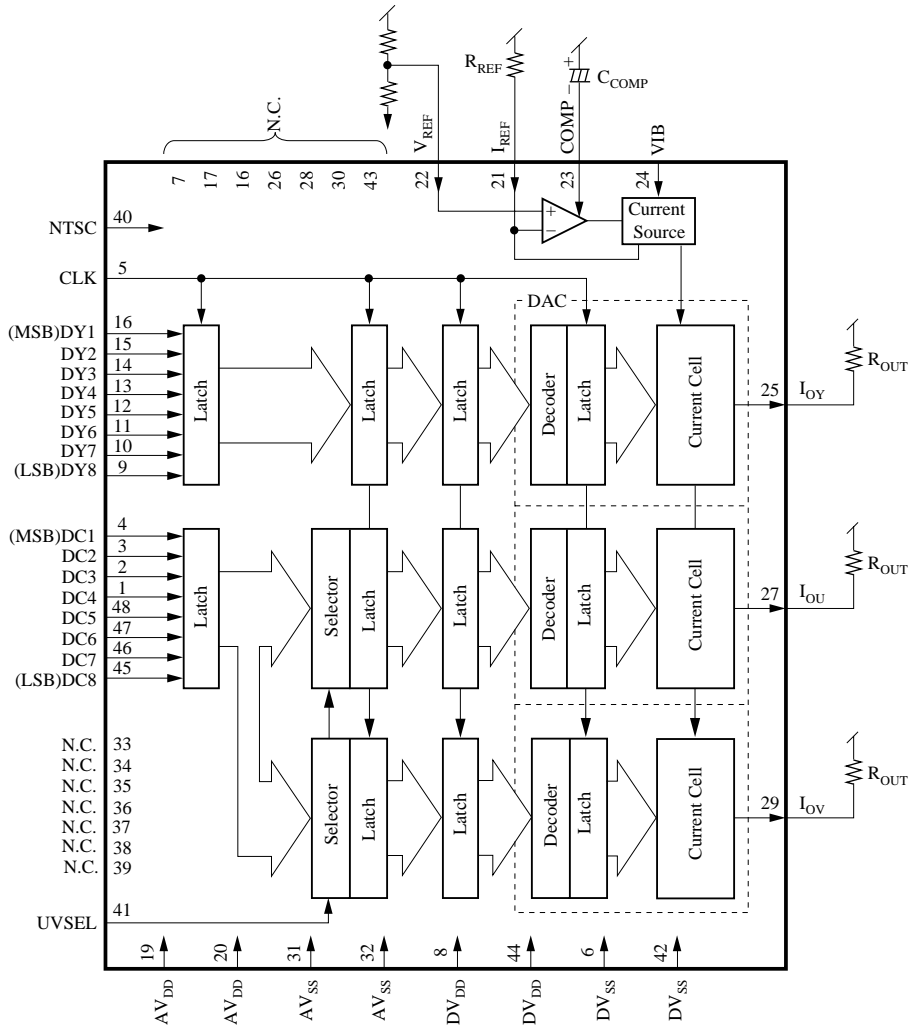

### ■ Pin Descriptions

Pin No.	Symbol	Function Description
1	DC4	C (chroma) digital input
2	DC3	C (chroma) digital input
3	DC2	C (chroma) digital input
4	DC1	C (chroma) digital input (MSB)
5	CLK	Sampling clock
6	DV <sub>SS</sub>	Ground for digital circuits
7	N.C.	No connection
8	DV <sub>DD</sub>	Power supply for digital circuits
9	DY8	Y (luminance) digital input (LSB)
10	DY7	Y (luminance) digital input
11	DY6	Y (luminance) digital input
12	DY5	Y (luminance) digital input
13	DY4	Y (luminance) digital input
14	DY3	Y (luminance) digital input
15	DY2	Y (luminance) digital input
16	DY1	Y (luminance) digital input (MSB)
17	N.C.	No connection
18	N.C.	No connection
19	AV <sub>DD</sub>	Power supply for analog circuits
20	AV <sub>DD</sub>	Power supply for analog circuits
21	I <sub>REF</sub>	Full scale adjustment resistor
22	V <sub>REF</sub>	Reference voltage input
23	COMP	Phase compensation
24	VIB	Capacitor connection
25	I <sub>OY</sub>	Y signal analog current output
26	N.C.	No connection
27	I <sub>OU</sub>	U signal analog current output
28	N.C.	No connection
29	I <sub>OV</sub>	V signal analog current output
30	N.C.	No connection
31	AV <sub>SS</sub>	Ground for analog circuits
32	AV <sub>SS</sub>	Ground for analog circuits
33	N.C.	No connection
34	N.C.	No connection
35	N.C.	No connection
36	N.C.	No connection
37	N.C.	No connection
38	N.C.	No connection
39	N.C.	No connection
40	NTCS	Format selection (two's complement/binary) for C (chroma) signal
41	UVSEL	U/V signal discrimination for C (chroma) signal
42	DV <sub>SS</sub>	Ground for digital circuits

### ■ Pin Descriptions (continued)

Pin No.	Symbol	Function Description
43	N.C.	No connection
44	DV <sub>DD</sub>	Power supply for digital circuits
45	DC8	C (chroma) digital input (LSB)
46	DC7	C (chroma) digital input
47	DC6	C (chroma) digital input
48	DC5	C (chroma) digital input

### ■ Absolute Maximum Ratings $T_a=25^\circ\text{C}$

Parameter	Symbol	Rating	Unit
Power supply voltage for digital circuits	DV <sub>DD</sub>	- 0.3 to +7.0	V
Power supply voltage for analog circuits	AV <sub>DD</sub>	- 0.3 to +7.0	V
Input voltage	V <sub>I</sub>	DV <sub>SS</sub> - 0.3 to DV <sub>DD</sub> +0.3	V
Output voltage	V <sub>O</sub>	AV <sub>SS</sub> - 0.3 to AV <sub>DD</sub> +0.3	V
Operating ambient temperature	T <sub>opr</sub>	-20 to +70	°C
Storage temperature	T <sub>stg</sub>	-55 to +125	°C

### ■ Recommended Operating Conditions $V_{DD}=AV_{DD}=DV_{DD}=3.5\text{V}$ , $V_{SS}=AV_{SS}=DV_{SS}=0\text{V}$ , $T_a=25^\circ\text{C}$

Parameter	Symbol	min	typ	max	Unit
Power supply voltage	V <sub>DD</sub>	3.4	3.5	3.6	V
Reference voltage	V <sub>REF</sub>	1.5	1.9	3.5	V
Reference resistance	R <sub>REF</sub>		820		Ω
External compensation capacitor	C <sub>COMP</sub>	0.33	1.0	3.3	μF
Output load resistance	R <sub>OUT</sub>		200		Ω
Digital input voltage	"H" level	V <sub>IH</sub>	V <sub>DD</sub> × 0.5	V <sub>DD</sub>	V
	"L" level	V <sub>IL</sub>	V <sub>SS</sub>	V <sub>DD</sub> × 0.16	V
Clock	"H" level pulse width	t <sub>WH</sub>	15		ns
	"L" level pulse width	t <sub>WL</sub>	15		ns

### ■ Electrical Characteristics $DV_{DD}=AV_{DD}=3.5\text{V}$ , $DV_{SS}=AV_{SS}=0\text{V}$ , $T_a=25^\circ\text{C}$

Parameter	Symbol	Conditions	min	typ	max	Unit
Power supply current	I <sub>DD</sub>	V <sub>DD</sub> =3.5V, f <sub>CLK</sub> =15MHz R <sub>OUT</sub> =200Ω, Output amplitude = 0.8V T=25°C		24	40	mA
Resolution	RES			8		bit
Linearity error	E <sub>L</sub>	V <sub>DD</sub> =3.5V, R <sub>OUT</sub> =200Ω		±0.2	±0.5	LSB
Differential linearity error	E <sub>D</sub>	R <sub>REF</sub> =820Ω		±0.2	±0.5	LSB
Full scale current	I <sub>FS</sub>	V <sub>REF</sub> =1.9V		4		mA
Setup time	t <sub>S</sub>		10			ns
Hold time	t <sub>H</sub>		10			ns
Settling time	t <sub>ST</sub>	V <sub>DD</sub> =3.5V, R <sub>OUT</sub> =200Ω		30	50	ns
Maximum conversion speed	F <sub>C(max.)</sub>	R <sub>REF</sub> =820Ω V <sub>REF</sub> =1.9V	20	33		MSPS
Analog output delay time	t <sub>d</sub>			10		ns

■ Timing Chart

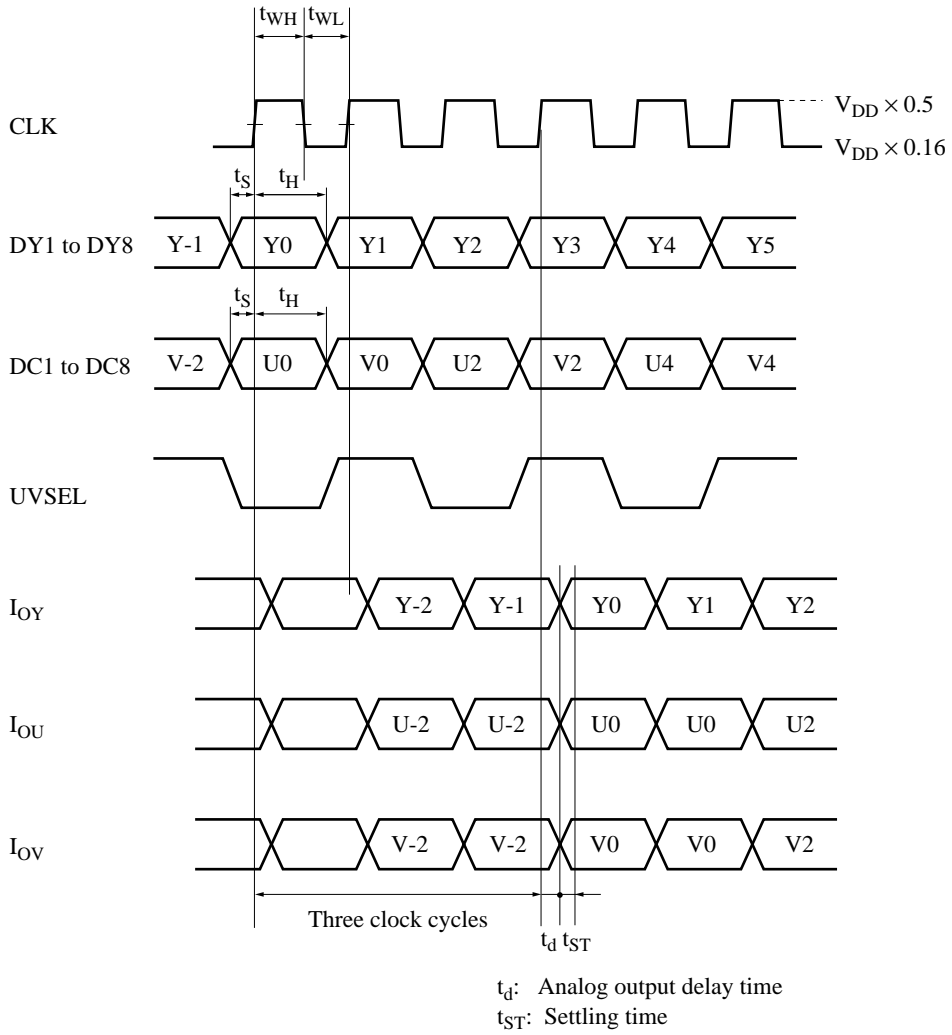

■ Package Dimensions (Unit:mm)

QFH048-P-0707

