

# BIPOLAR ANALOG INTEGRATED CIRCUIT

# $\mu$ PC2798GR

## IF DOWN CONVERTOR IC FOR DIGITAL CATV

### DESCRIPTION

The  $\mu$ PC2798GR is a Silicon monolithic IC designed for use as QAM IF down convertor for digital CATV. This IC consists of AGC amplifier, mixer, oscillator, and video amplifier.

The package is 20 pins SSOP suitable for high-density surface mount.

### FEATURES

- Low distortion AGC amplifier  $IIP_3 = -9$  dBm
- On chip IF convertor  $f_{in} = 30$  to 250 MHz
- On chip video amplifier  $V_{out} = 3.0$  V<sub>P-P</sub> (differential, @  $R_L = 1k\Omega$ )
- Supply voltage: 5 V
- Packaged in 20 pins SSOP suitable for high-density surface mount.

### ORDERING INFORMATION

PART NUMBER	PACKAGE	PACKAGE STYLE
$\mu$ PC2798GR-E1	20 pins plastic SSOP (225 mil)	Embossed tape 12 mm wide. 2.5 k/REEL. Pin 1 indicates pull-out direction of tape

\*: For evaluation sample order, please contact your local NEC office.

(Part number for sample order:  $\mu$ PC2798GR)

Please refer to "Quality grade on NEC Semiconductor Devices" (Document number C11531E) published by NEC Corporation to know the specification of quality grade on the devices and its recommended applications.

**Caution electro-static sensitive device**

The information in this document is subject to change without notice. Before using this document, please confirm that this is the latest version.  
Not all devices/types available in every country. Please check with local NEC representative for availability and additional information.

INTERNAL BLOCK DIAGRAM AND PIN CONFIGURATION (Top View)

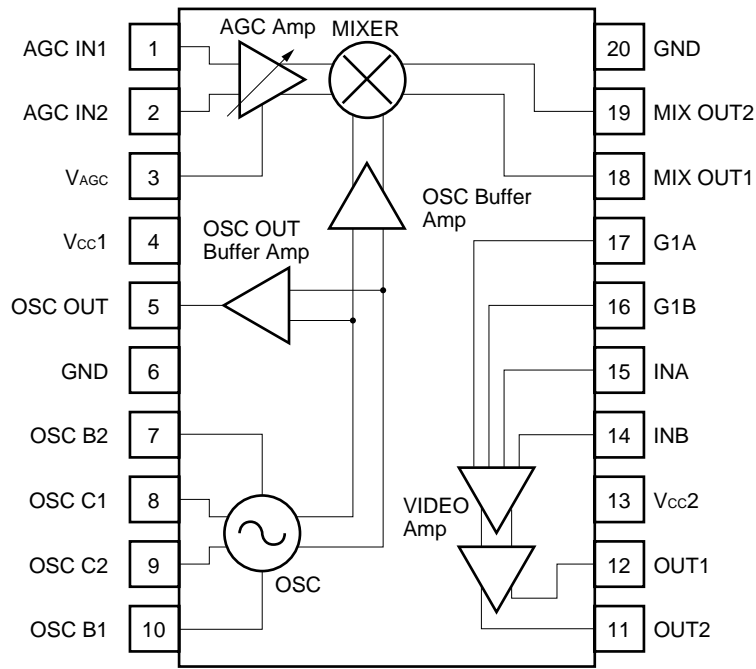

PIN EXPLANATIONS

Pin No.	Symbol	Pin Voltage (V, TYP.)	Explanation	Equivalent Circuit
1	AGC IN1	1.5	Input pin of IF signal. 1pin is same phase and 2pin is opposite phase at balance input. In case of single input, 1pin or 2pin should be grounded through capacitor.	
2	AGC IN2	1.5		
3	V <sub>AGC</sub>	0 to 5	Automatic gain control pin. This pin's bias govern the AGC output level. Minimum gain at V <sub>AGC</sub> = 0 V Maximum gain at V <sub>AGC</sub> = 5 V Recommend to use by deviding AGC voltage with externally resistor (ex. 100 kΩ).	
4	Vcc1	5.0	Power supply pin of IF down convertor block. Must be connected bypass capacitor to minimize ground impedance.	
5	OSC OUT	4.0	Output pin of Oscillator frequency. Connected to PLL synthesizer IC's input pin.	
6	GND	0.0	Ground pin. Must be connected to the system ground with minimum inductance. Ground pattern on the board should be formed as wide as possible.	
7	OSC B2	2.4	Internal oscillator consist in balance amplifier. 7 and 8pins, 9 and 10 pins should be externally connected to oscillate with active feedback loop. Connected LC resonator between 7pin and 10pin.	
8	OSC C1	4.6		
9	OSC C2	4.6		
10	OSC B1	2.4		

PIN EXPLANATIONS

Pin No.	Symbol	Pin Voltage (V, TYP.) ( ) is value at Vcc2 = 9 V.	Explanation	Equivalent Circuit
11	OUT2	2.5 (4.7)	Output pin of video amplifier. In case of $R_L = 1\text{ k}\Omega$ , differential output voltage equal $3\text{ V}_{P-P}$ . OUT1 and INA are same phase. OUT2 and INB are same phase.	
11	OUT1	2.5 (4.7)		
13	Vcc2	5 to 9	Power supply pin of video amplifier. Must be connected bypass capacitor to minimize ground impedance.	
14	INB	2.5 (4.1)	Signal input pin of video amplifier. This pin is high impedance.	
15	INA	2.5 (4.1)		
16	G1B	1.7 (3.3)	Gain control pin of video amplifier. Maximum gain at G1A-G1B = short. Minimum gain at G1A-G1B = open. Gain is able to adjust by inserting arbitrary resistor between 16pin and 17pin.	
17	G1A	1.7 (3.3)		
18	MIX OUT1	3.7	Output pin of mixer. This output pin features low-impedance because of its emitter-follower output port.	
19	MIX OUT2	3.7		
20	GND	0.0	Ground pin. Must be connected to the system ground with minimum inductance. Ground pattern on the board should be formed as wide as possible.	

**ABSOLUTE MAXIMUM RATINGS (T<sub>A</sub> = 25 °C unless otherwise specified)**

PARAMETER	SYMBOL	RATING	UNIT	TEST CONDITIONS
Supply Voltage 1	V <sub>cc1</sub>	6.0	V	Mixer block
Supply Voltage 2	V <sub>cc2</sub>	6.0	V	Video Amp block
Power Dissipation	P <sub>D</sub>	430	mW	T <sub>A</sub> = 85 °C <sup>1</sup>
Operating Ambient Temperature	T <sub>A</sub>	-40 to +85	°C	
Storage Temperature	T <sub>stg</sub>	-55 to +150	°C	

PARAMETER	SYMBOL	RATING	UNIT	TEST CONDITIONS
Supply Voltage 1	V <sub>cc1</sub>	6.0	V	Mixer block
Supply Voltage 2	V <sub>cc2</sub>	11.0	V	Video Amp block
Power Dissipation	P <sub>D</sub>	500	mW	T <sub>A</sub> = 75 °C <sup>1</sup>
Operating Ambient Temperature	T <sub>A</sub>	-40 to +75	°C	
Storage Temperature	T <sub>stg</sub>	-55 to +150	°C	

\*1. Mounted on 50 × 50 × 1.6 mm double copper epoxy glass board.

**RECOMMENDED OPERATING RANGE**

PARAMETER	SYMBOL	MIN.	TYP.	MAX.	UNIT
Supply Voltage 1	V <sub>cc1</sub>	4.5	5.0	5.5	V
Supply Voltage 2	V <sub>cc2</sub>	4.5	5.0	10.0	V
Operating Ambient Temperature 1 <sup>2</sup>	T <sub>A1</sub>	-40	+25	+85	°C
Operating Ambient Temperature 2 <sup>3</sup>	T <sub>A2</sub>	-40	+25	+75	°C

\*2. @V<sub>cc1</sub> = V<sub>cc2</sub> = 4.5 to 5.5 V

\*3. @V<sub>cc1</sub> = 4.5 to 5.5 V, V<sub>cc2</sub> = 4.5 to 10.0 V

**ELECTRICAL CHARACTERISTICS (T<sub>A</sub> = 25 °C)**

PARAMETER	SYMBOL	MIN.	TYP.	MAX.	UNIT	TEST CONDITIONS
Total Block (R <sub>L</sub> = 1 kΩ, by measurement circuit 5)						
Circuit Current 1	I <sub>cc1</sub>	24.0	35.5	45.0	mA	no input signal, V <sub>cc1</sub> = V <sub>cc2</sub> = 5 V
Maximum Conversion Gain 1	CG <sub>MAX1</sub>	68.0	74.0	76.0	dB	V <sub>AGC</sub> = 4.0 V, G1A-G1B pins: short <sup>4</sup>
Maximum Conversion Gain 2	CG <sub>MAX2</sub>	—	58.0	—	dB	V <sub>AGC</sub> = 4.0 V, G1A-G1B pins: open <sup>4</sup>
Minimum Conversion Gain 1	CG <sub>MIN1</sub>	32.0	39.0	43.0	dB	V <sub>AGC</sub> = 1.0 V, G1A-G1B pins: short <sup>4</sup>
Minimum Conversion Gain 2	CG <sub>MIN2</sub>	—	22.0	—	dB	V <sub>AGC</sub> = 1.0 V, G1A-G1B pins: open <sup>4</sup>
Circuit Current 2	I <sub>cc1</sub>	32.0	47.0	60.0	mA	no input signal, V <sub>cc1</sub> = 5 V, V <sub>cc2</sub> = 9 V
Maximum Conversion Gain 3	CG <sub>MAX3</sub>	72.0	78.5	81.0	dB	V <sub>AGC</sub> = 4.0 V, G1A-G1B pins: short <sup>4</sup>
Maximum Conversion Gain 4	CG <sub>MAX4</sub>	—	59.0	—	dB	V <sub>AGC</sub> = 4.0 V, G1A-G1B pins: open <sup>4</sup>
Minimum Conversion Gain 3	CG <sub>MIN3</sub>	—	43.5	—	dB	V <sub>AGC</sub> = 1.0 V, G1A-G1B pins: short <sup>4</sup>
Minimum Conversion Gain 4	CG <sub>MIN4</sub>	—	22.5	—	dB	V <sub>AGC</sub> = 1.0 V, G1A-G1B pins: open <sup>4</sup>

**ELECTRICAL CHARACTERISTICS (T<sub>A</sub> = 25 °C)**

PARAMETER	SYMBOL	MIN.	TYP.	MAX.	UNIT	TEST CONDITIONS
AGC Amplifier + Mixer Block (@V <sub>cc1</sub> = 5 V, R <sub>L</sub> = 50 Ω, by measurement circuit 1)						
Circuit Current 3	I <sub>cc3</sub>	15.0	23.0	28.0	mA	no input signal
RF Input Frequency Range	f <sub>RF</sub>	30	—	250	Mhz	
OSC Frequency Range	f <sub>osc</sub>	30	—	250	Mhz	
IF Output Frequency Range	f <sub>IF</sub>	DC	—	150	Mhz	
Minimum Conversion Gain 5	CG <sub>MAX5</sub>	—	25	—	dB	V <sub>AGC</sub> = 4.0 V <sup>*4</sup>
Minimum Conversion Gain 5	CG <sub>MIN5</sub>	—	-7	—	dB	V <sub>AGC</sub> = 1.0 V <sup>*4</sup>
AGC Dynamic Range	GCR	26	32	—	dB	V <sub>AGC</sub> = 1.0 to 4.0 V
Noise Figure	NF	—	9	—	dB	SSB, V <sub>AGC</sub> = 4.0 V (@Maximum Gain) <sup>*4,5</sup>
AGC Voltage High Level	V <sub>AGCH</sub>	4.0	—	—	V	@Maximum Gain
AGC Voltage Low Level	V <sub>AGCL</sub>	—	—	1.0	V	@Minimum Gain
Video Amp. Block (@V <sub>cc2</sub> = 5 V, R <sub>L</sub> = 1 kΩ, Input: 51 Ω terminated, by measurement circuit 3)						
Circuit Current 4	I <sub>cc4</sub>	9.0	12.5	17.0	mA	no input signal
Differential Gain 1	G1	—	200	—	V/V	G1A-G1B pins: short, V <sub>out</sub> = 3.0 V <sub>P-P</sub> , fin = 10 MHz
Differential Gain 2	G2	—	26.0	—	V/V	G1A-G1B pins: open, V <sub>out</sub> = 3.0 V <sub>P-P</sub> , fin = 10 MHz
Video Amp. Block (@V <sub>cc2</sub> = 9 V, R <sub>L</sub> = 1 kΩ, Input: 51 Ω terminated, by measurement circuit 3)						
Circuit Current 5	I <sub>cc5</sub>	17.0	24.0	32.0	mA	no input signal
Differential Gain 3	G3	—	385	—	V/V	G1A-G1B pins: short, V <sub>out</sub> = 3.0 V <sub>P-P</sub> , fin = 10 MHz
Differential Gain 4	G4	—	28.5	—	V/V	G1A-G1B pins: open, V <sub>out</sub> = 3.0 V <sub>P-P</sub> , fin = 10 MHz
Video Amp. Block (@V <sub>cc2</sub> = 5 V or 9 V: Common, R <sub>L</sub> = 1 kΩ, Input: 51 Ω terminated, by measurement circuit 3)						
Output Voltage	V <sub>OUT</sub>	—	3.0	—	V <sub>P-P</sub>	R <sub>L</sub> = 1 kΩ, differential
Bandwidth 1	BW <sub>G1</sub>	—	50	—	MHz	G1 (G1A-G1B pins: short)
Bandwidth 2	BW <sub>G2</sub>	—	50	—	MHz	G2 (G1A-G1B pins: open)
Input Resistance 1	R <sub>in1</sub>	—	3.5	—	kΩ	G1 (G1A-G1B pins: short)
Input Resistance 2	R <sub>in2</sub>	—	9.7	—	kΩ	G2 (G1A-G1B pins: open)
Input Capacitance	C <sub>in</sub>	—	1.6	—	pF	

\*4. f<sub>RF</sub> = 45 MHz, f<sub>osc</sub> = 55 MHz, P<sub>osc</sub> = -10 dBm

\*5. By measurement circuit 2

STANDARD CHARACTERISTICS (TA = 25 °C)

PARAMETER	SYMBOL	VALUE FOR REFERENCE	UNIT	TEST CONDITIONS
AGC Amplifier + Mixer Block (@Vcc1 = 5 V, by measurement circuit 1)				
AGC Input Intercept Point 1	AGC IIP <sub>31</sub>	-9	dBm	V <sub>AGC</sub> = 1.0 V @Minimum Gain *6
Video Amp. Block (R <sub>L</sub> = 50 Ω, input: 51 Ω terminated, by measurement circuit 4)				
Single-end Gain 1	A <sub>vs1</sub>	40.0	dB	V <sub>cc2</sub> = 5 V, G1A-G1B pins: short
Single-end Gain 2	A <sub>vs2</sub>	22.5	dB	V <sub>cc2</sub> = 5 V, G1A-G1B pins: open
Single-end Gain 3	A <sub>vs3</sub>	45.0	dB	V <sub>cc2</sub> = 9 V, G1A-G1B pins: short
Single-end Gain 4	A <sub>vs4</sub>	23.5	dB	V <sub>cc2</sub> = 9 V, G1A-G1B pins: open
Input Intercept Point 2	IIP <sub>32</sub>	-11.5	dBm	V <sub>cc2</sub> = 5 V, G1A-G1B pins: open fin1 = 9 MHz, fin2 = 11 MHz
Input Intercept Point 3	IIP <sub>33</sub>	-5.0	dBm	V <sub>cc2</sub> = 9 V, G1A-G1B pins: open fin1 = 9 MHz, fin2 = 11 MHz
Video Amp. Block (@Vcc2 = 5 V or 9 V: Common, by measurement circuit 3)				
Common Mode Rejection Ratio	CMRR	80	dB	V <sub>CM</sub> = 1 V <sub>P-P</sub> , f = 100 kHz
Power Supply Rejection Ratio	PSRR	70	dB	
Rise Time	τ <sub>R</sub>	2.6	ns	
Propagation Delay Time	τ <sub>PD</sub>	4.4	ns	
Total Block (R <sub>L</sub> = 1 kΩ, by measurement circuit 5)				
Input Intercept Point 4	IIP <sub>34</sub>	-14.0	dBm	V <sub>cc1</sub> = V <sub>cc2</sub> = 5 V, V <sub>AGC</sub> = 1 V, G1A-G1B pins: short *6
Input Intercept Point 5	IIP <sub>35</sub>	-8.0	dBm	V <sub>cc1</sub> = V <sub>cc2</sub> = 5 V, V <sub>AGC</sub> = 1 V, G1A-G1B pins: open *6
Input Intercept Point 6	IIP <sub>36</sub>	-7.5	dBm	V <sub>cc1</sub> = 5 V, V <sub>cc2</sub> = 9 V, V <sub>AGC</sub> = 1 V, G1A-G1B pins: open *6

\*6 f<sub>RF1</sub> = 44 MHz, f<sub>RF2</sub> = 46 MHz, f<sub>osc</sub> = 55 MHz, P<sub>osc</sub> = -10 dBm

TYPICAL CHARACTERISTICS

(by measurement circuit 5,  $T_A = 25\text{ }^\circ\text{C}$ ,  $f_{osc} = f_{RF} + 10\text{ MHz}$ ,  $P_{osc} = -10\text{ dBm}$ )

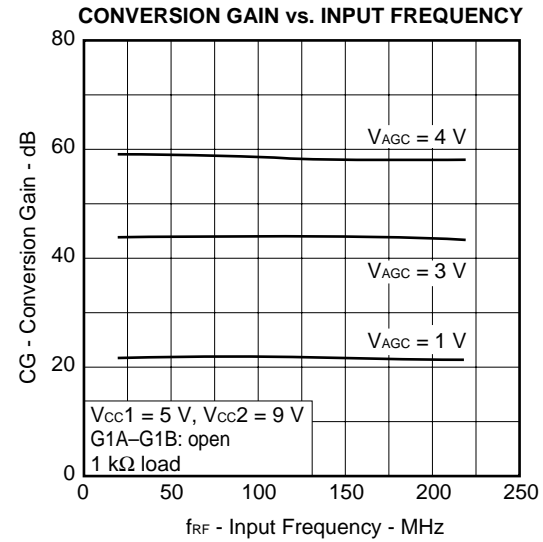
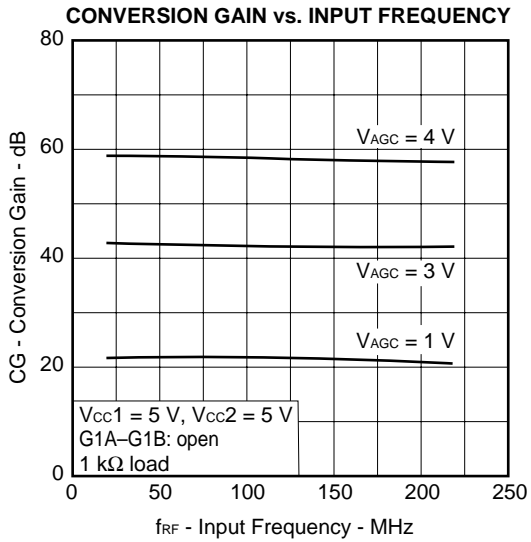
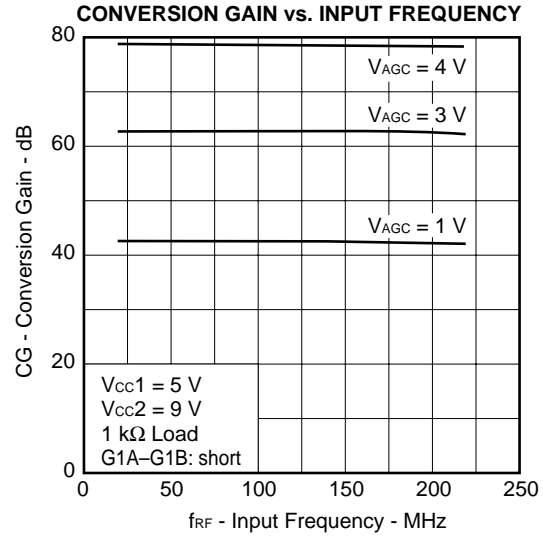
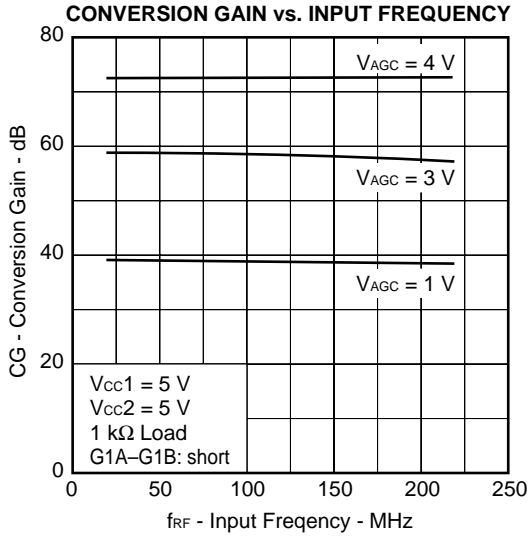



TYPICAL CHARACTERISTICS

(by measurement circuit 5,  $T_A = 25^\circ\text{C}$ ,  $f_{RF} = 45\text{ MHz}$ ,  $P_{Osc} = -10\text{ dBm}$ )

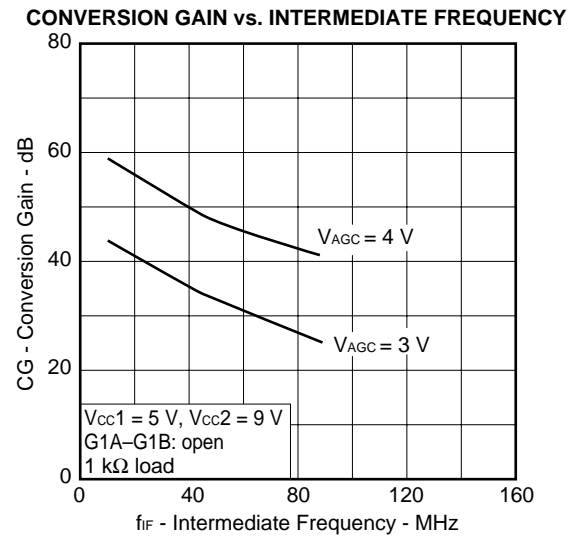
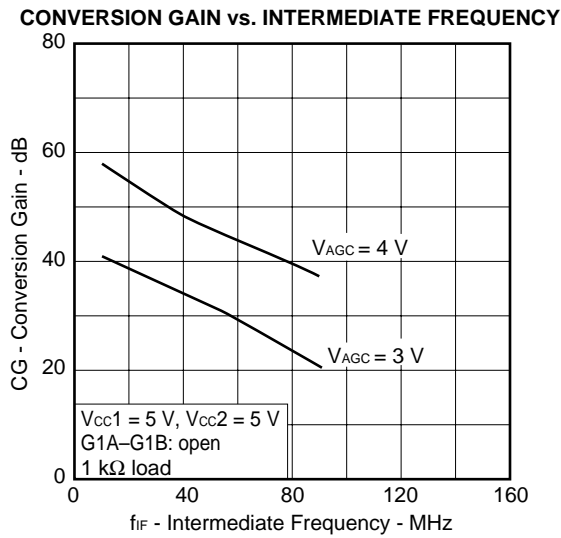
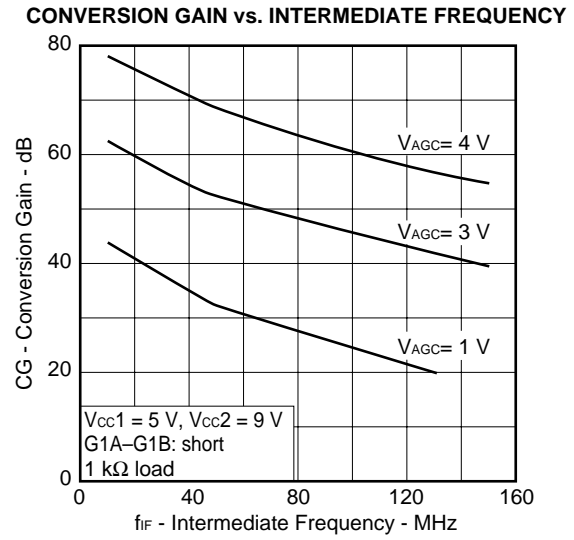
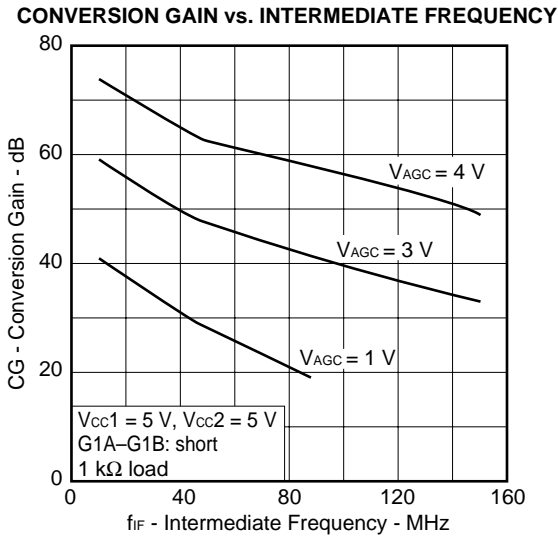

TYPICAL CHARACTERISTICS (by measurement circuit 1, T<sub>A</sub> = 25 °C)

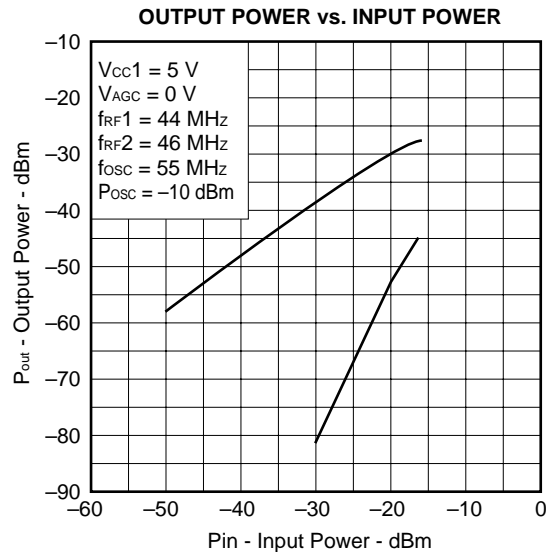
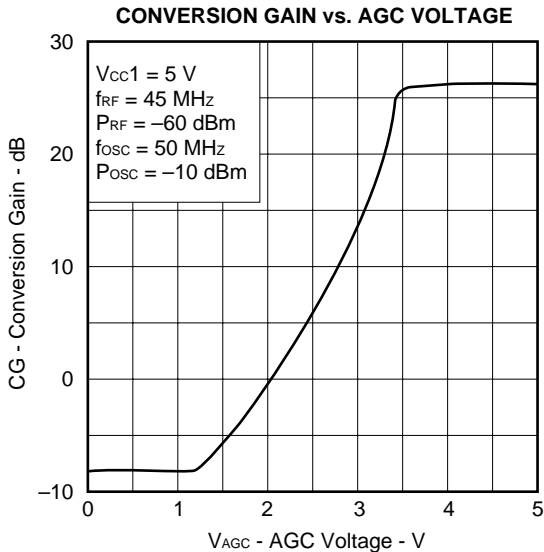
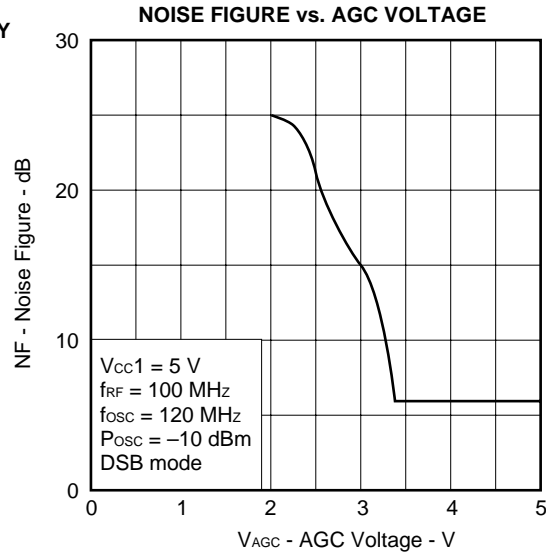
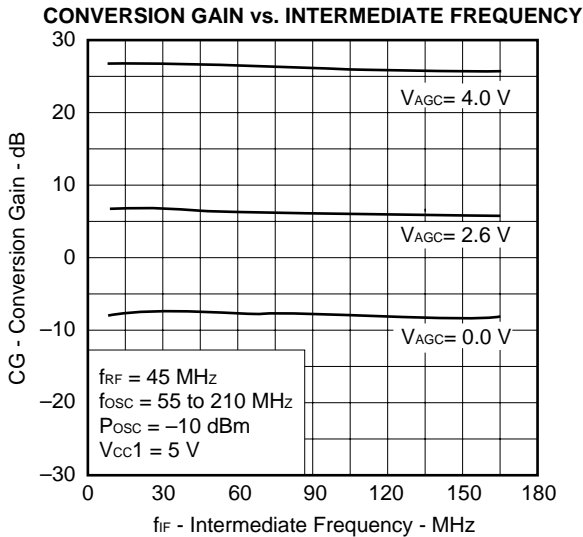
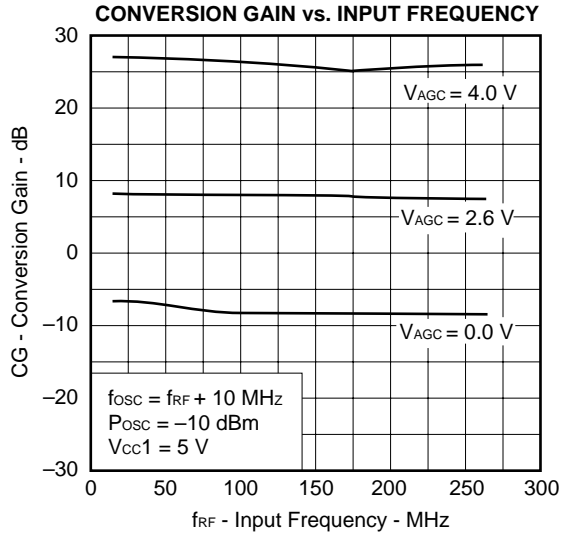
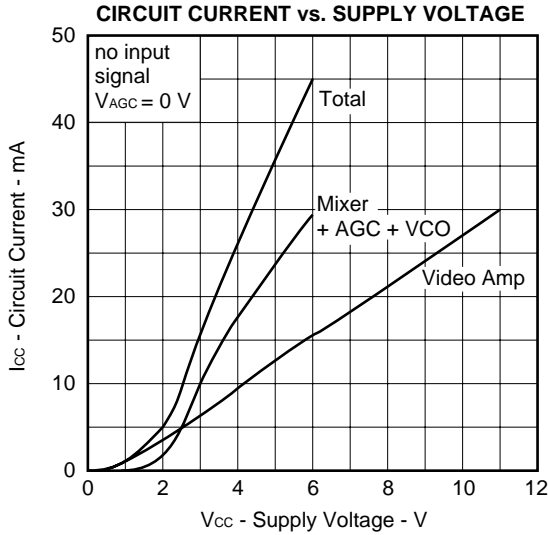

STANDARD CHARACTERISTICS (by measurement circuit 3,  $T_A = 25\text{ }^\circ\text{C}$ )

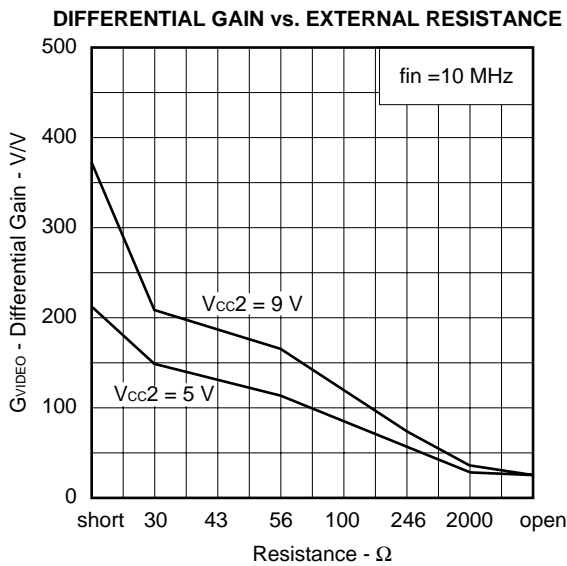
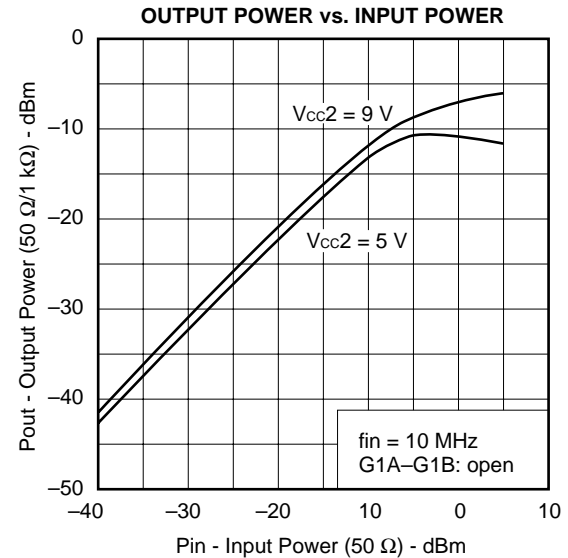
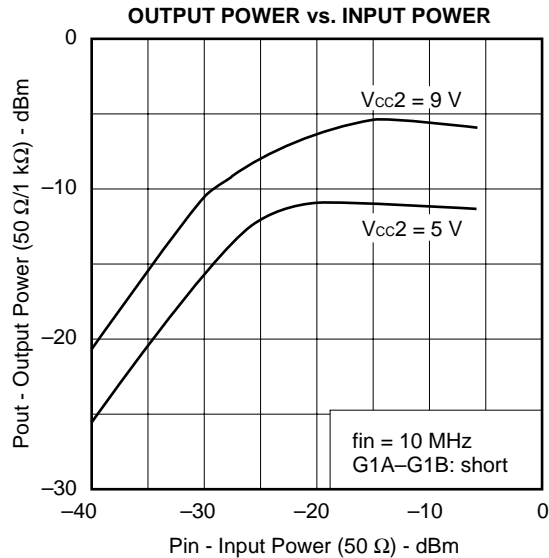
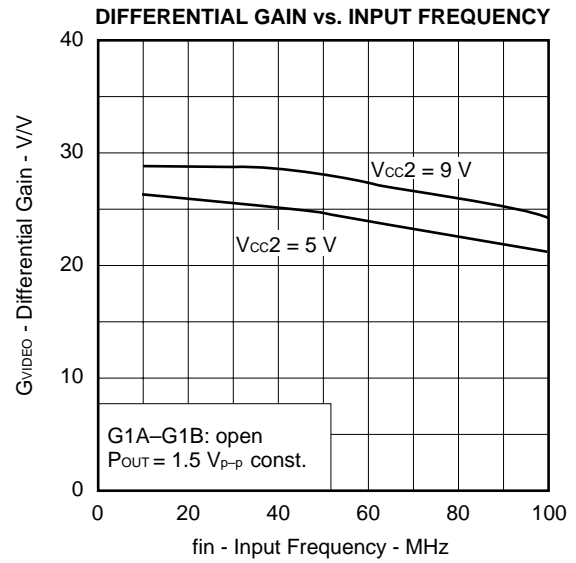
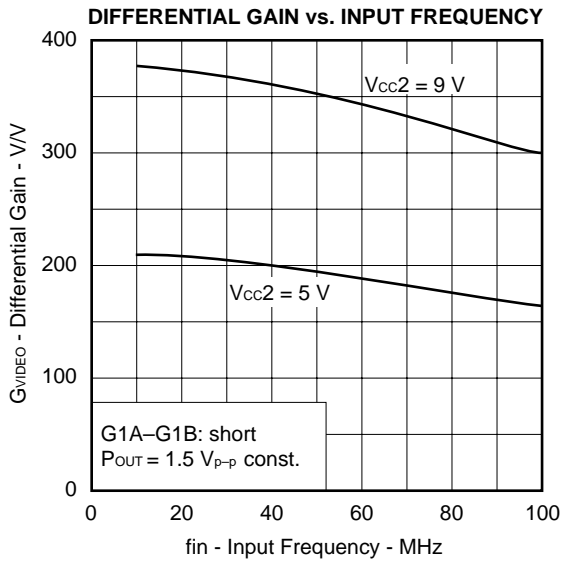

STANDARD CHARACTERISTICS (by measurement circuit 4, T<sub>A</sub> = 25 °C)

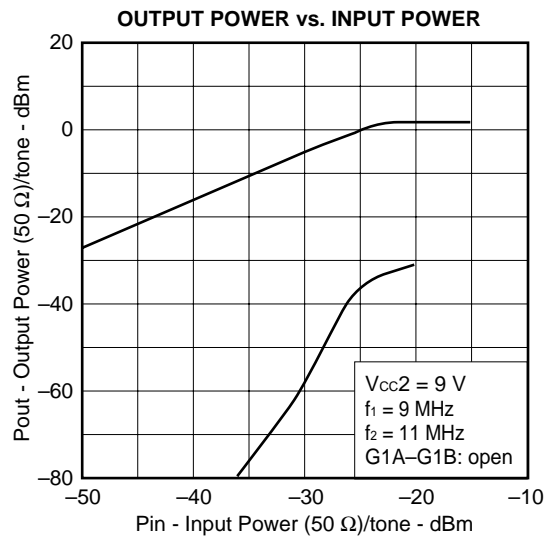
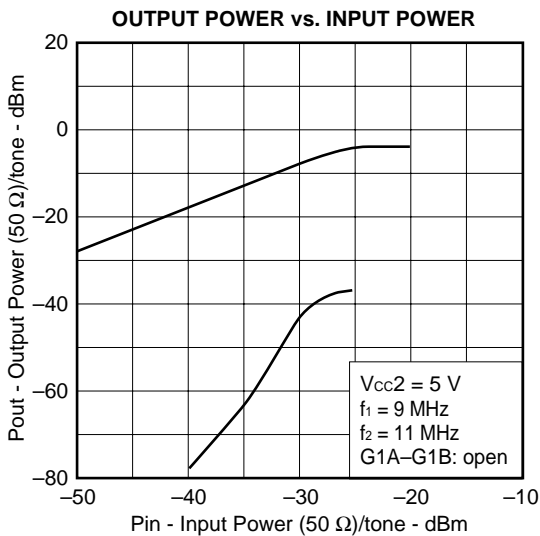
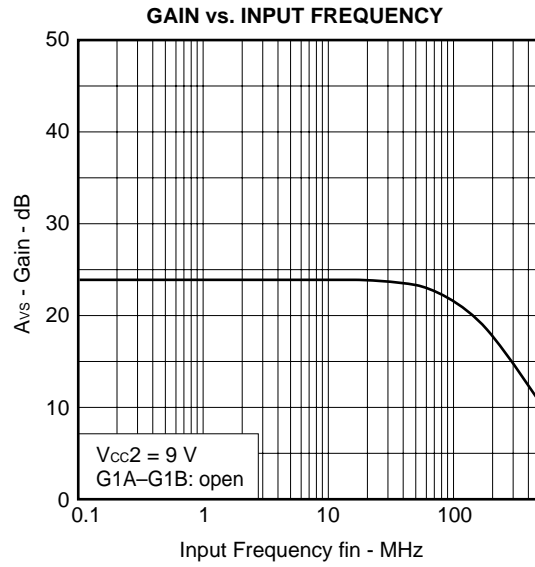
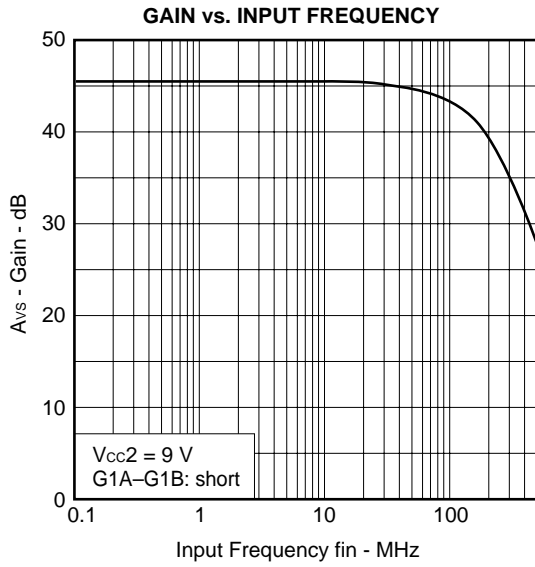
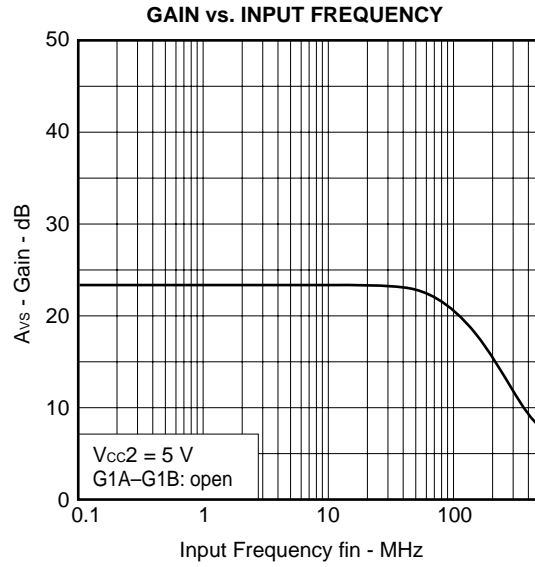
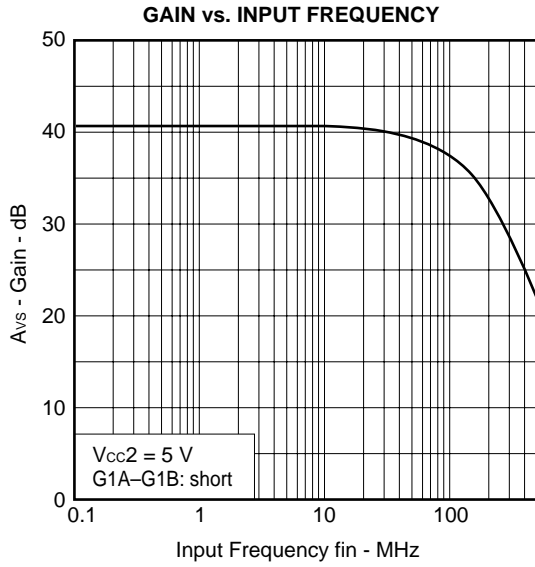

STANDARD CHARACTERISTICS (by measurement circuit 5)

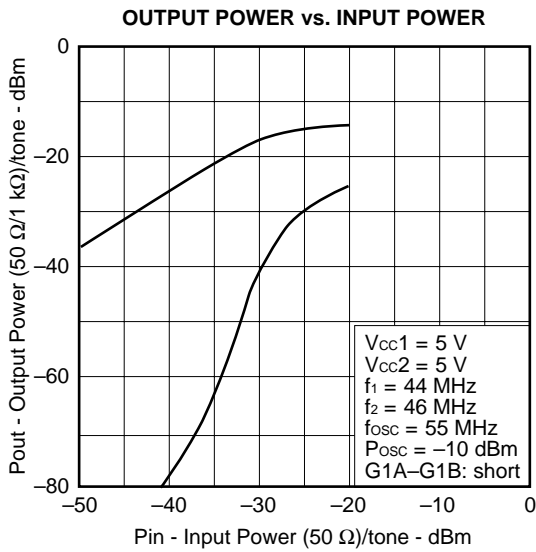
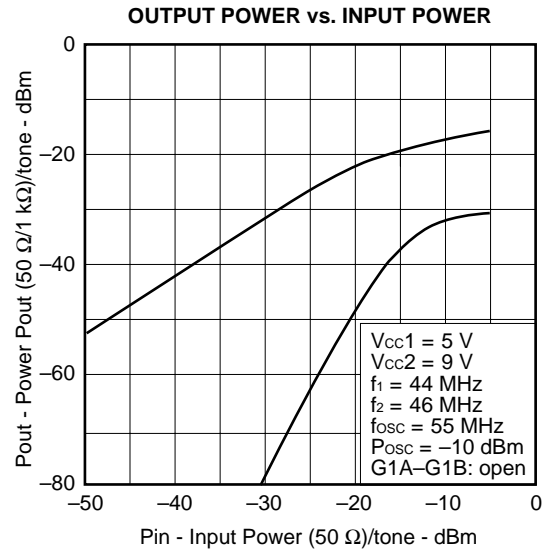
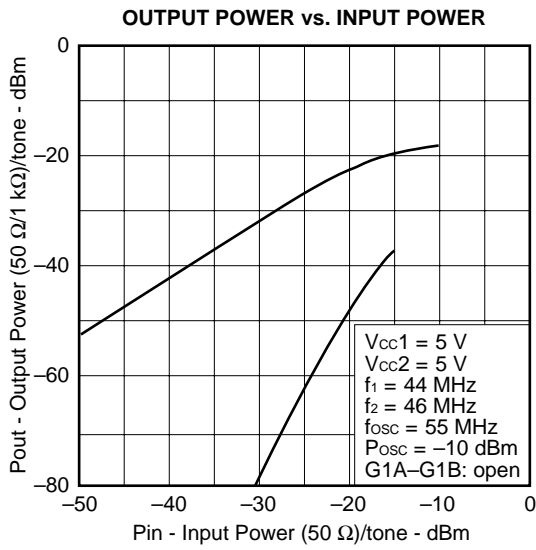

**STANDARD CHARACTERISTICS**

(by application circuit example: MIXER block, T<sub>A</sub> = 25 °C)

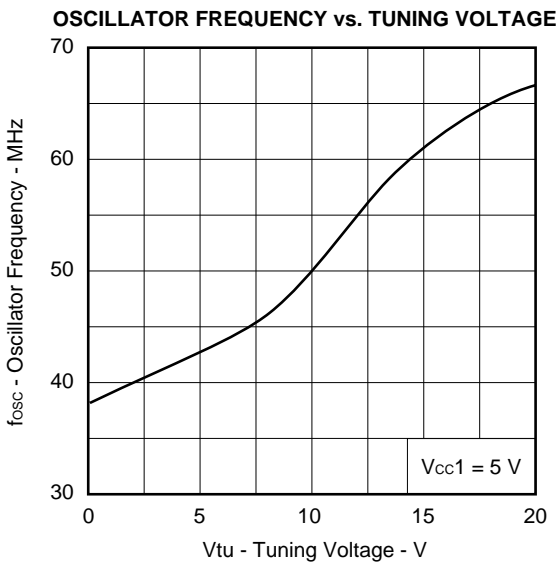
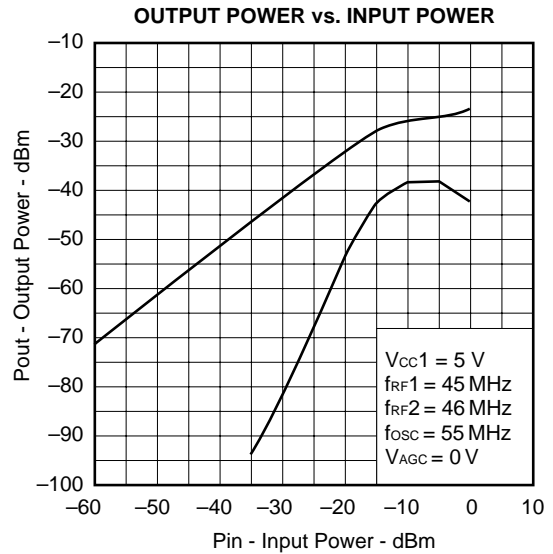
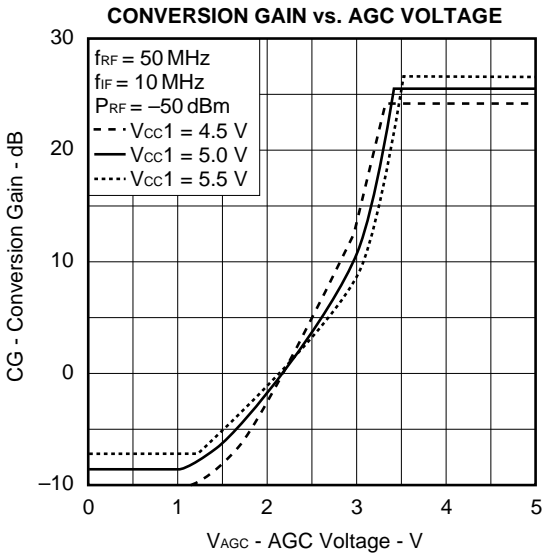
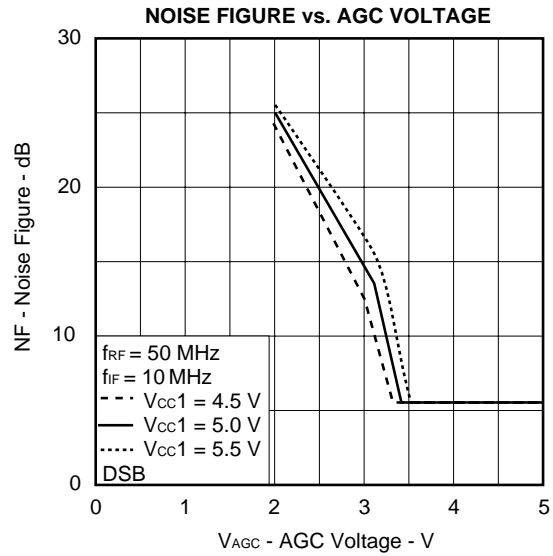
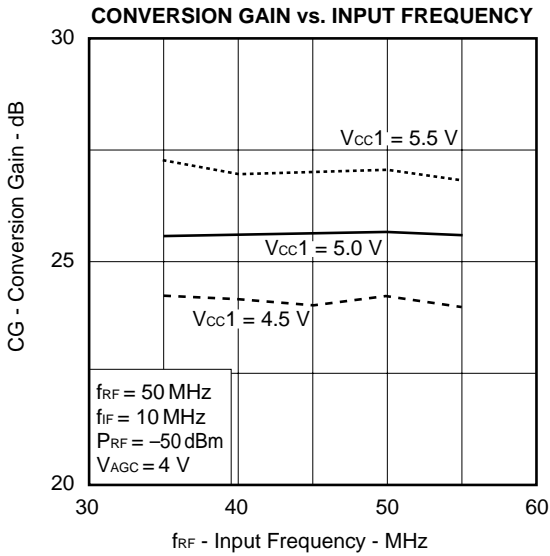

MEASUREMENT CIRCUIT 1

<AGC + MIX block>

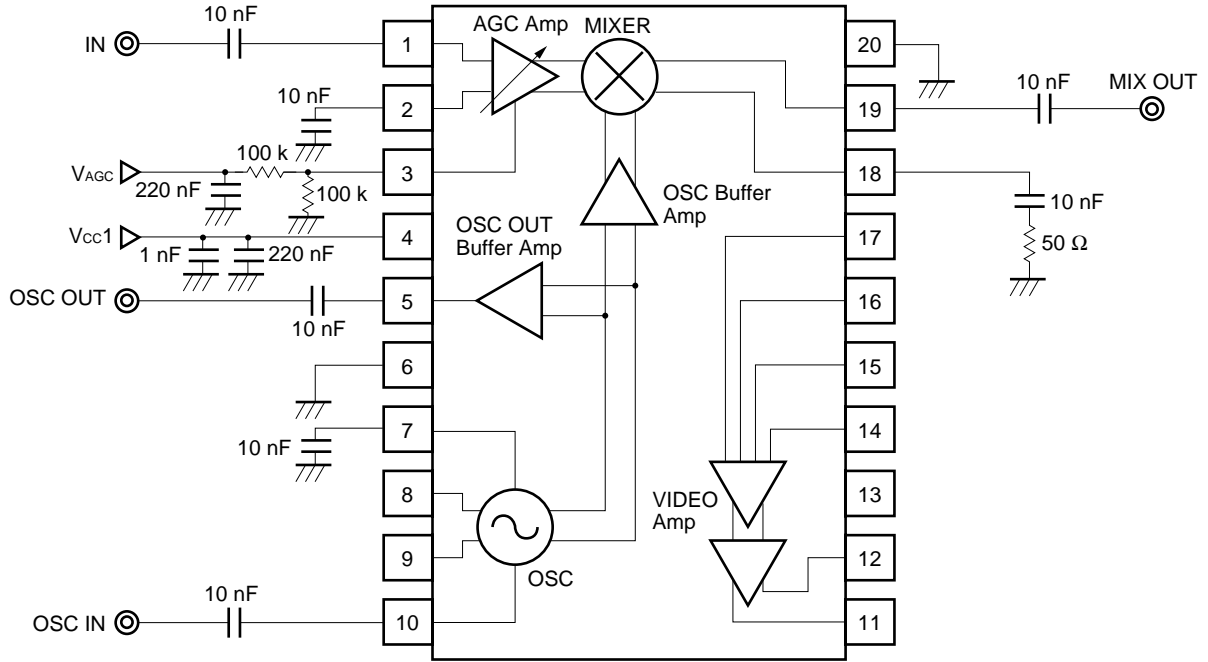

MEASUREMENT CIRCUIT 2

<AGC + MIX block>

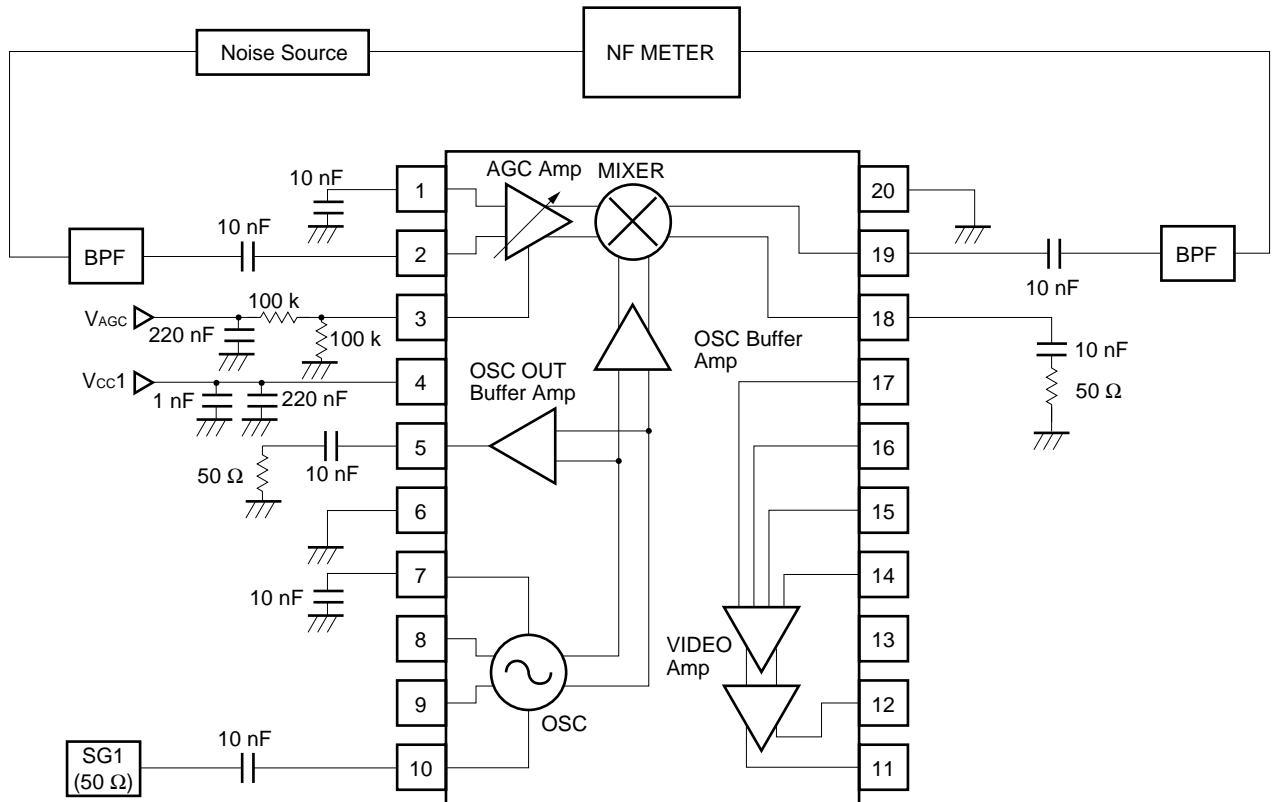

MEASUREMENT CIRCUIT 3

<Video Amp. block>

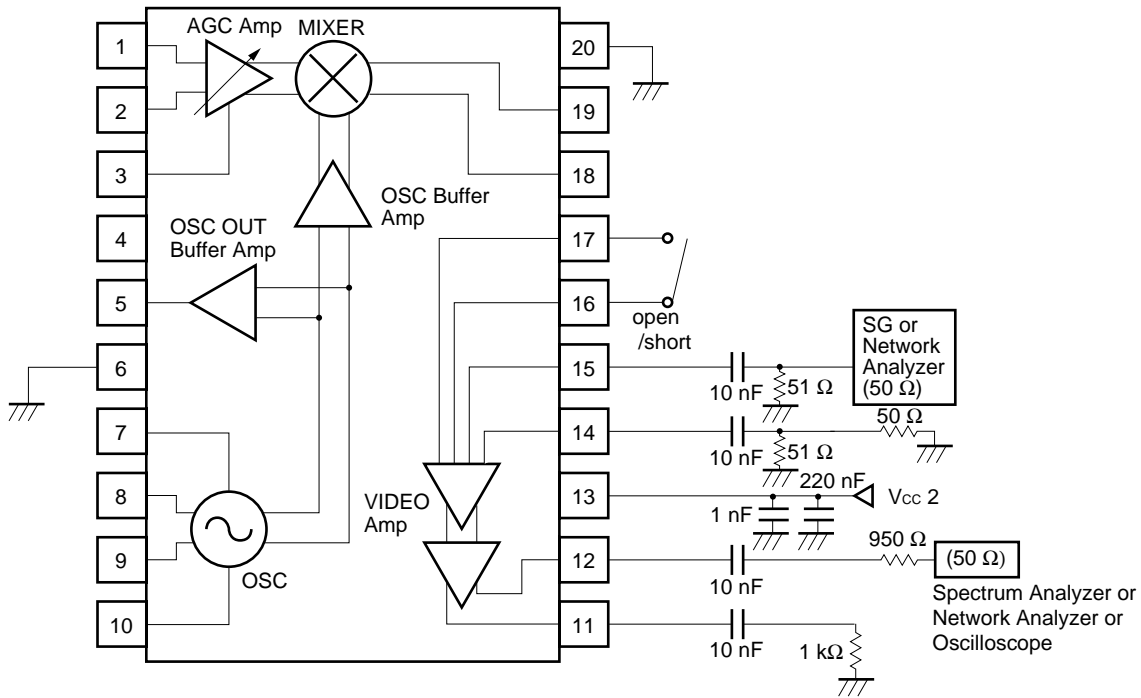

MEASUREMENT CIRCUIT 4

<Video Amp. block>

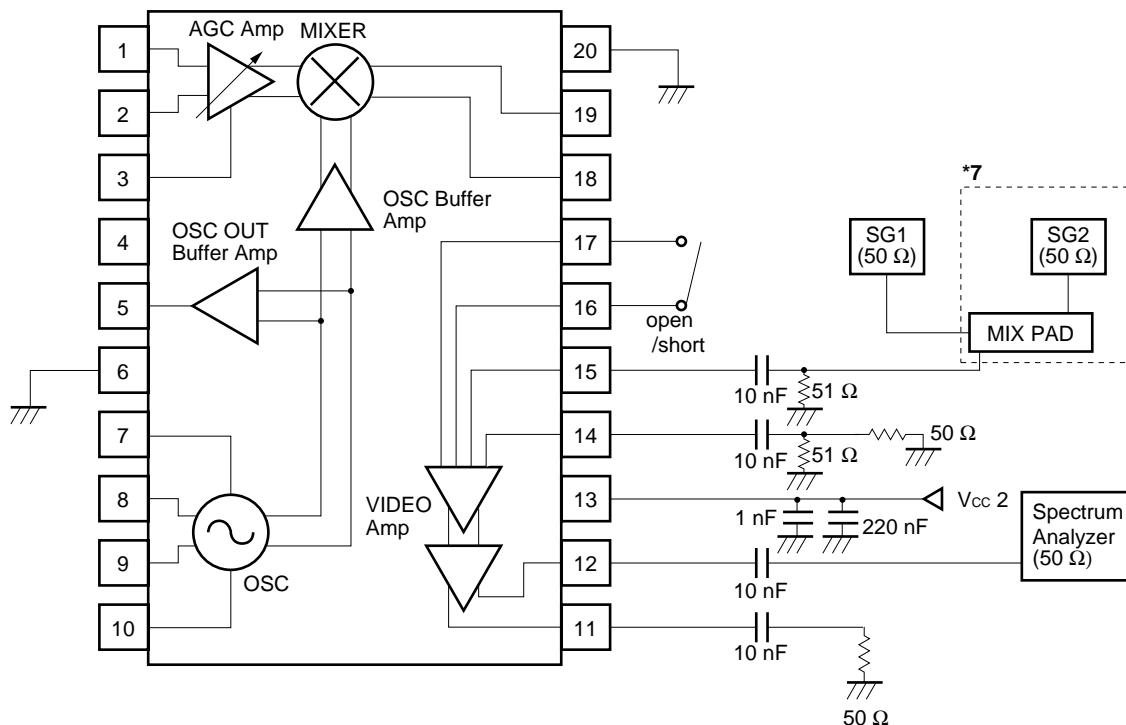

\*7: In case of measurement of IIP3



MEASUREMENT CIRCUIT 5

<Total block>

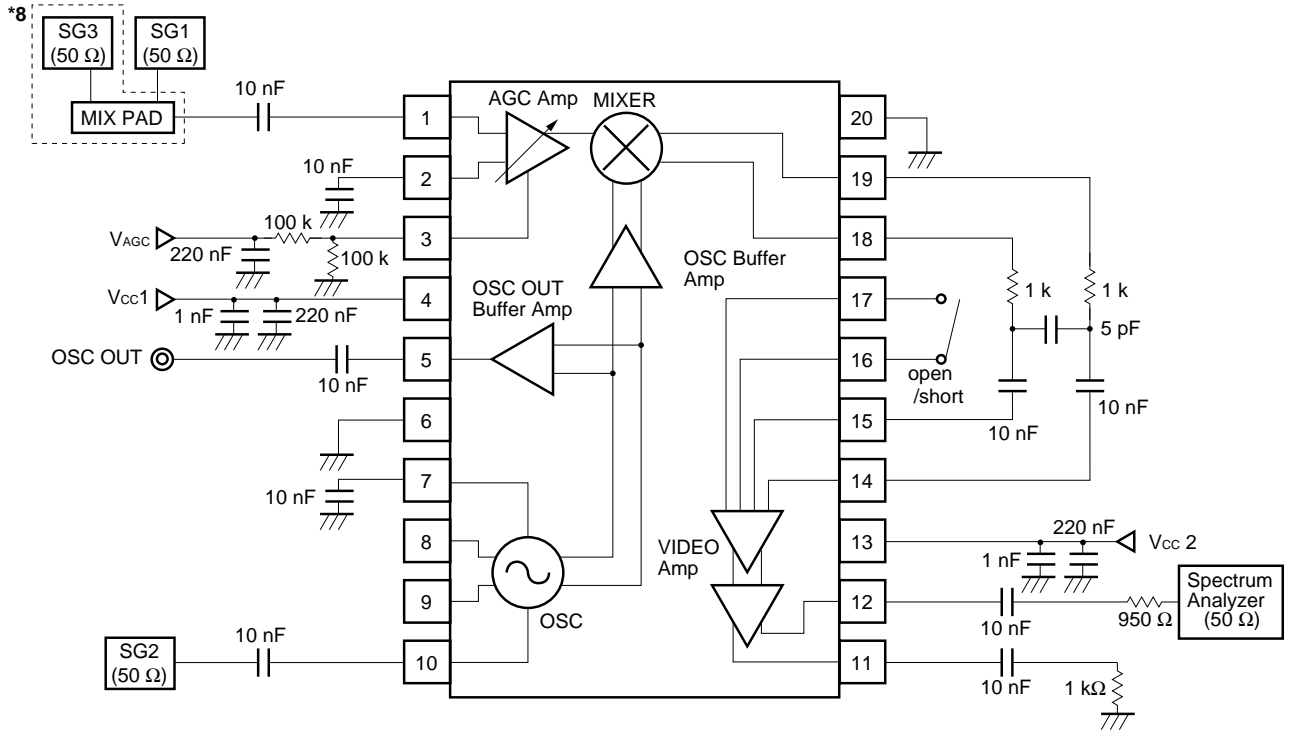

\*8: In case of measurement of IIP3

APPLICATION CIRCUIT EXAMPLE

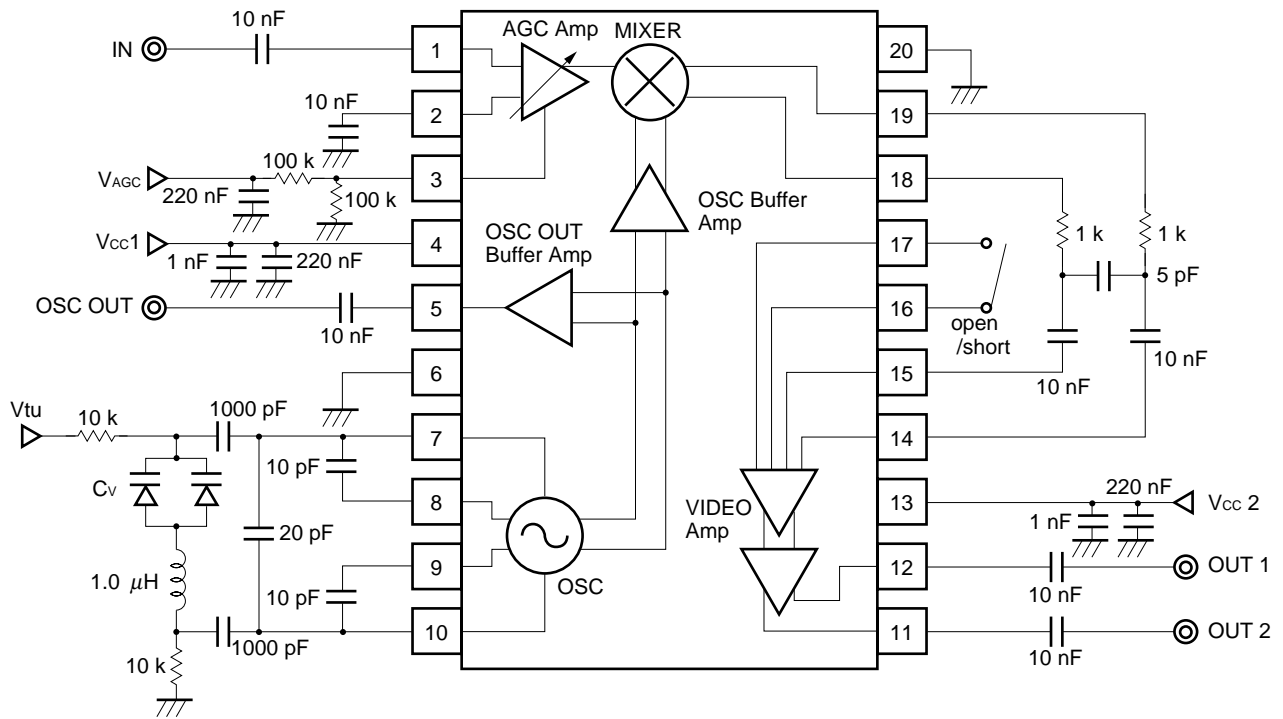

Cv: N ratio = 10 to 11 (ex. HVU 200 A)

The application circuits and their parameters are for reference only and are not intended for use in actual design-ins.

ILLUSTRATION OF THE APPLICATION CIRCUIT ASSEMBLED ON EVALUATION BOARD

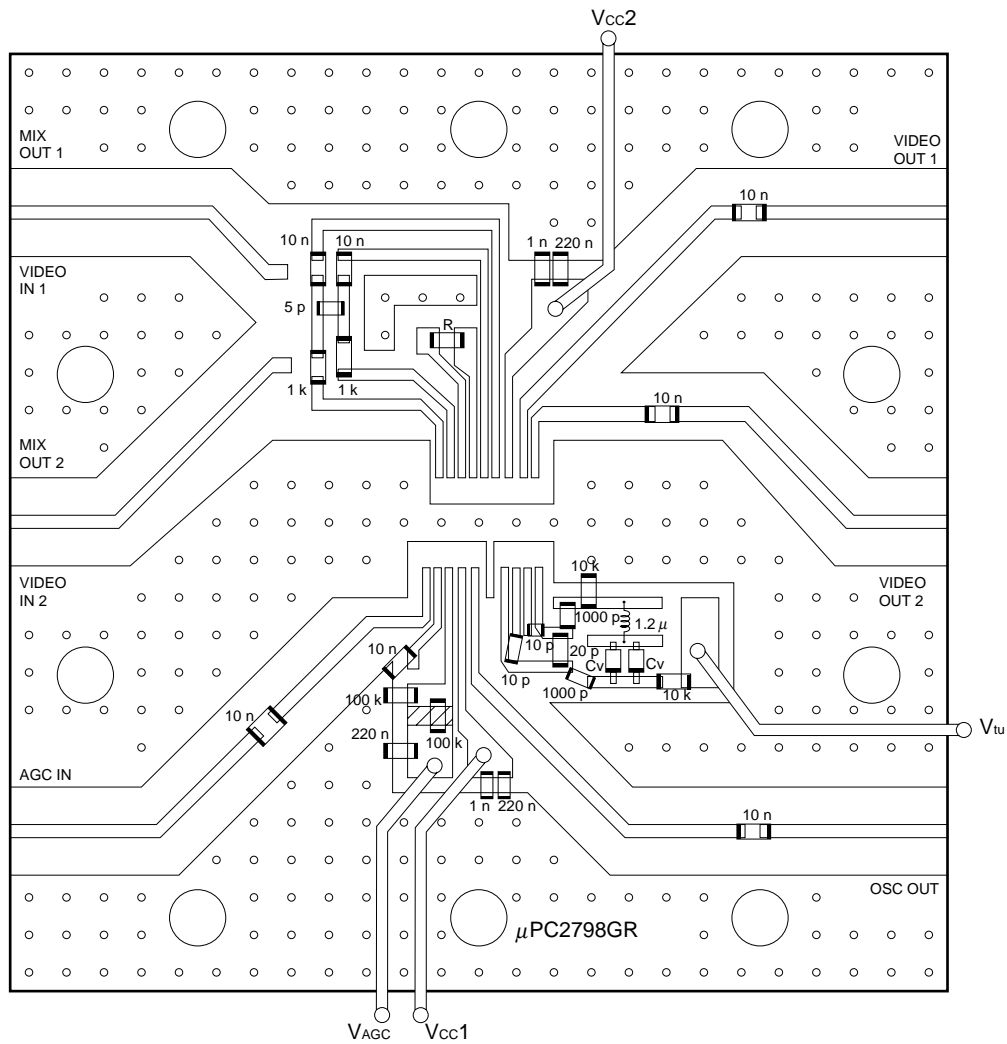

Notes

- \*1) R is resistance to control video amplifier gain. (short to open)
- \*2) Cv is variable capacitor. (N ratio = 10 to 11, Example: HVU200A)
- \*3) ○ shows through holes
- \*4) pattern should be removed on this application

PACKAGE DIMENSIONS

★ 20 PIN PLASTIC SSOP (225 mil) (UNIT: mm)

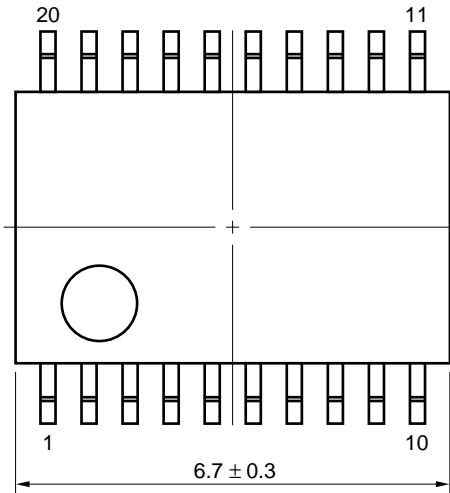

detail of lead end

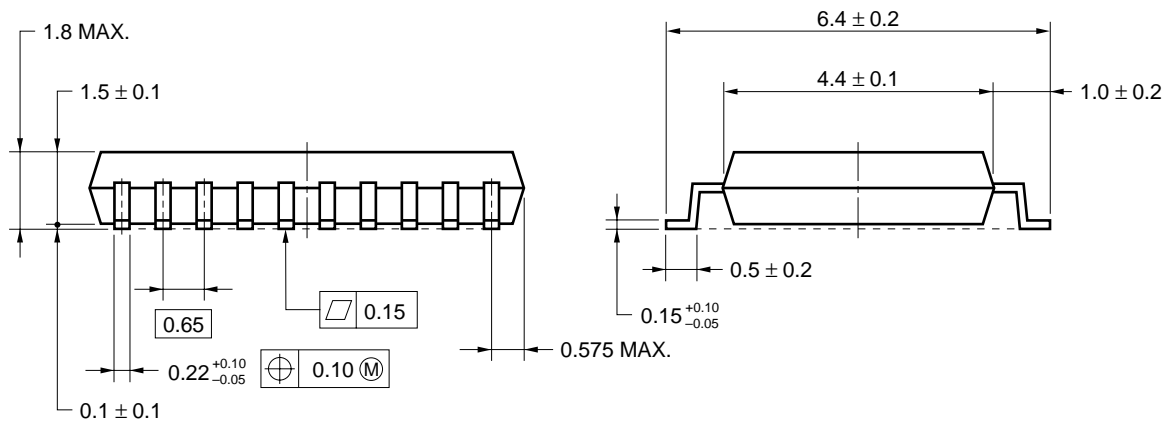
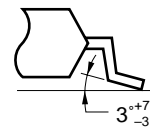

**NOTE** Each lead centerline is located within 0.10 mm of its true position (T.P.) at maximum material condition.

**RECOMMENDED SOLDERING CONDITIONS**

The following conditions (see table below) must be met when soldering this product.

Please consult with our sales officers in case other soldering process is used or in case soldering is done under different conditions.

For details of recommended soldering conditions for surface mounting, refer to information document **SEMICONDUCTOR DEVICE MOUNTING TECHNOLOGY MANUAL (C10535E)**.

**μPC2798GR**

Soldering process	Soldering conditions	Symbol
Infrared ray reflow	Peak package's surface temperature: 235 °C or below, Reflow time: 30 seconds or below (210 °C or higher), Number of reflow process: 3, Exposure limit <sup>Note</sup> : None	IR35-00-3
VPS	Peak package's surface temperature: 215 °C or below, Reflow time: 40 seconds or below (200 °C or higher), Number of reflow process: 3, Exposure limit <sup>Note</sup> : None	VP15-00-3
Partial heating method	Terminal temperature: 300 °C or below, Flow time: 3 seconds or below, Exposure limit <sup>Note</sup> : None	

**Note** Exposure limit before soldering after dry-pack package is opened.

Storage conditions: 25 °C and relative humidity at 65% or less.

**Caution** Do not apply more than single process at once, except for "Partial heating method".

[MEMO]

[MEMO]

**NESAT (NEC Silicon Advanced Technology) is trademark of NEC Corporation.**

- **The information in this document is subject to change without notice. Before using this document, please confirm that this is the latest version.**
  - No part of this document may be copied or reproduced in any form or by any means without the prior written consent of NEC Corporation. NEC Corporation assumes no responsibility for any errors which may appear in this document.
  - NEC Corporation does not assume any liability for infringement of patents, copyrights or other intellectual property rights of third parties by or arising from use of a device described herein or any other liability arising from use of such device. No license, either express, implied or otherwise, is granted under any patents, copyrights or other intellectual property rights of NEC Corporation or others.
  - Descriptions of circuits, software, and other related information in this document are provided for illustrative purposes in semiconductor product operation and application examples. The incorporation of these circuits, software, and information in the design of the customer's equipment shall be done under the full responsibility of the customer. NEC Corporation assumes no responsibility for any losses incurred by the customer or third parties arising from the use of these circuits, software, and information.
  - While NEC Corporation has been making continuous effort to enhance the reliability of its semiconductor devices, the possibility of defects cannot be eliminated entirely. To minimize risks of damage or injury to persons or property arising from a defect in an NEC semiconductor device, customers must incorporate sufficient safety measures in its design, such as redundancy, fire-containment, and anti-failure features.
  - NEC devices are classified into the following three quality grades:  
"Standard", "Special", and "Specific". The Specific quality grade applies only to devices developed based on a customer designated "quality assurance program" for a specific application. The recommended applications of a device depend on its quality grade, as indicated below. Customers must check the quality grade of each device before using it in a particular application.
    - Standard: Computers, office equipment, communications equipment, test and measurement equipment, audio and visual equipment, home electronic appliances, machine tools, personal electronic equipment and industrial robots
    - Special: Transportation equipment (automobiles, trains, ships, etc.), traffic control systems, anti-disaster systems, anti-crime systems, safety equipment and medical equipment (not specifically designed for life support)
    - Specific: Aircraft, aerospace equipment, submersible repeaters, nuclear reactor control systems, life support systems or medical equipment for life support, etc.
- The quality grade of NEC devices is "Standard" unless otherwise specified in NEC's Data Sheets or Data Books. If customers intend to use NEC devices for applications other than those specified for Standard quality grade, they should contact an NEC sales representative in advance.