

Features

- Loop Start Trunk Interface
- 600 Ohm input impedance
- Line state detection outputs:
 - forward loop
 - reverse loop
 - ringing voltage
 - service out
- Transformerless 2W to 4W conversion
- One loop start relay driver
- +/- 5V operation

Applications

Interface to Central Office for:

- PABX
- Key Telephone Systems
- Channel Bank
- Voice Mail
- Terminal Equipment
- Digital Loop Carrier
- Optical Multiplexer

ISSUE 3

April 1995

Ordering Information

MH88634K 21 Pin SIL Package

0°C to 70°C
Description

The Mitel MH88634K Central Office Trunk Interface circuit provides a complete audio and signalling link between audio switching equipment and a central office. The functions provided by the MH88634K include 2-4 Wire conversion, 600 Ohm input impedance and network balance. The device is fabricated as a thick film hybrid incorporating various technologies for optimum circuit design and very high reliability.

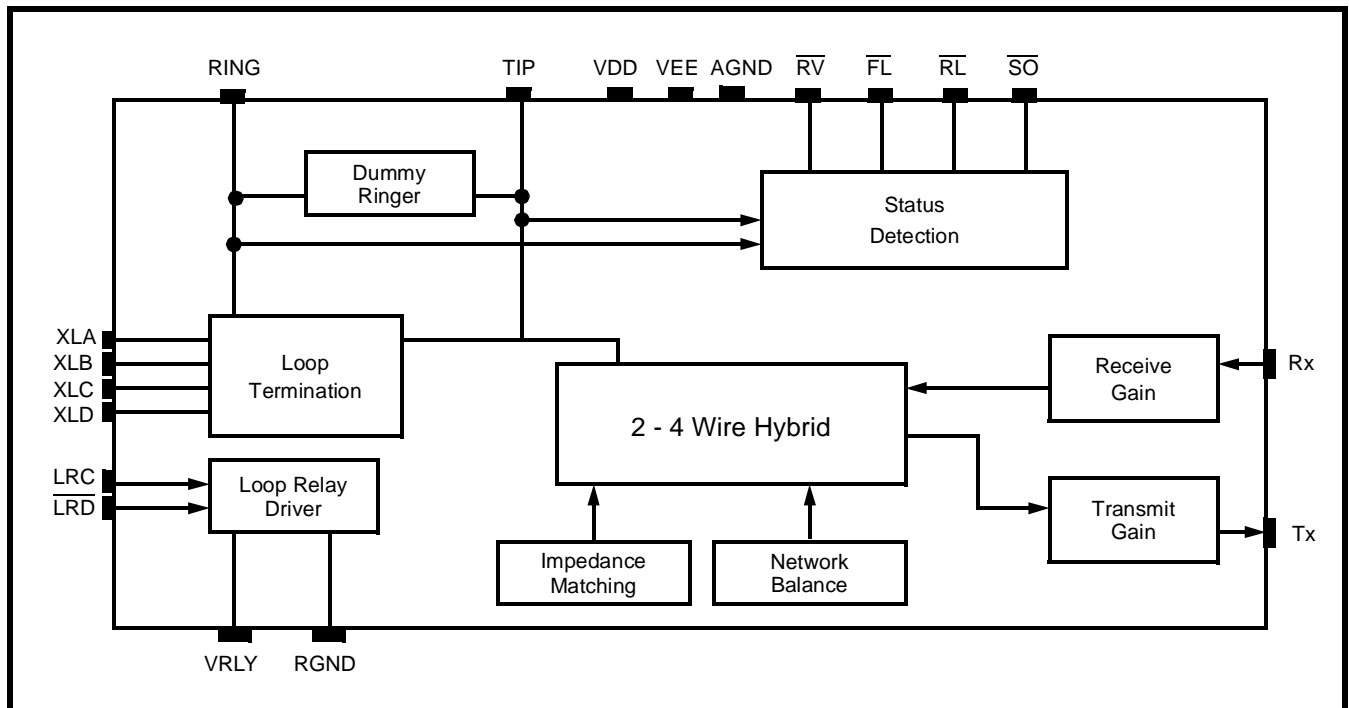
Figure 1 - Functional Block Diagram

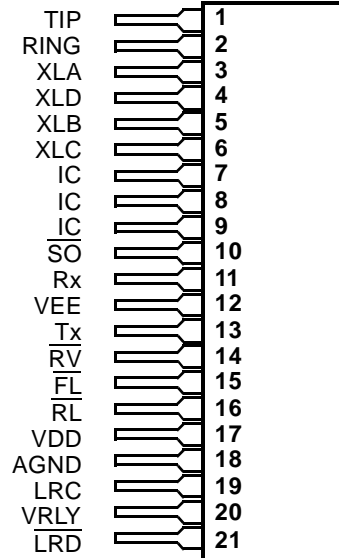

Figure 2 - Pin Connections

Pin Description

Pin #	Name	Description
1	TIP	Tip Lead. Connects to the “Tip” lead of the central office
2	RING	Ring Lead: Connects to the “Ring” lead of the central office
3	XLA	Loop Relay Contact A: Connects to XLB through the Loop relay (K1) contacts when the relay is activated. This operates the internal active termination circuitry.
4	XLD	Loop Relay Contact D: See XLC for description
5	XLB	Loop Relay Contact B: See XLA for description
6	XLC	Loop Relay Contact C: Connects to XLD through the loop relay (K1) contacts when the relay is activated. This operates the internal active termination circuitry.
7	IC	Internal Connection: This pin is internally connected and must be left open.
8	IC	Internal Connection.: This pin is internally connected and must be left open.
9	IC	Internal Connection: This pin is internally connected and must be left open.
10	\overline{SO}	Service Out Detect (Output). A logic low indicates that the central office “Tip” and “Ring” are out of service.
11	Rx	Receive (Input): 4-Wire ground (AGND) referenced audio input.
12	VEE	Negative Supply Voltage. -5V
13	Tx	Transmit (Output). 4-Wire ground (AGND) referenced audio output.
14	\overline{RV}	Ring Voltage Detect (Output). A logic low indicates that ringing voltage is across the Tip and Ring leads. Note that this output toggles at the ringing cadence and not at the ringing frequency.
15	\overline{FL}	Forward Loop Detect (Output). In the on-hook state, a logic low output indicates that forward loop battery is present. In the off-hook state, a logic low indicates that forward loop current is present
16	\overline{RL}	Reverse Loop Detect (Output): In the on-hook state, a logic low output indicates that reverse loop battery is present. In the off-hook state, a logic low output indicates that reverse loop current is present. Reverse loop refers to the Tip lead negative respect to the Ring lead.

Pin Description (Continued)

Pin #	Name	Description
17	VDD	Positive Supply Voltage: +5V
18	AGND	Analog Ground: 4-wire ground. Connected to system ground.
19	LRC	Loop Relay Control (Input): A logic high activates the Loop Relay Driver output ($\overline{\text{LRD}}$). The Loop Relay activates internal circuitry which provides a DC termination across Tip and Ring. Used for line seizure and dial pulsing.
20	VRLY	Relay Positive Supply Voltage: Typically +5V. Connects to the relay coil and the relay supply voltage
21	$\overline{\text{LRD}}$	Loop Relay Drive (Output): Connects to the Loop Relay Coil. A logic low activates the relay. An internal clamp diode from VRLY to $\overline{\text{LRD}}$ is provided.

Functional Description

The MH88634K is a COIC (Central Office Interface Circuit) used to interface the Central Office 2-Wire Analog Trunks. The COIC provides a Loop Start interface function.

Incoming analog (voiceband) signals from the 2-Wire circuit are applied differentially across Tip and Ring, the output of which is applied to the 2 to 4 wire converter with a fixed gain to the Tx output.

The outgoing analog signals are applied to Rx. The audio signals undergo 4 to 2 wire conversion with a fixed gain, and are differentially applied to Tip and Ring.

DC Loop Termination

The line is provided with an active DC load termination when a logic high is applied to the LRC (Loop Start Relay) input. The termination is similar to a DC resistance of less than 275 ohms. An external relay is used to activate internal circuitry which switches the termination in and out of the loop. This is used for both seizing the line as well as generating dial pulses.

Supervision Features

The supervision circuitry provides the signalling status outputs. The ringing voltage, forward current, reverse current and Service Out. Ringing Voltage detect - the RV output provides a logic low when ringing voltage is detected. This sector includes a ringing filter which ensures that the output toggles at the ringing cadence and not at the ringing frequency. Typically, this output goes low 50ms after the ringing voltage is applied and remains low for 50ms after ringing voltage is removed.

Forward loop and reverse loop detect - the $\overline{\text{FL}}$ output provides a logic low when either forward loop battery or forward loop current is detected (ring lead voltage negative with respect to tip lead). The $\overline{\text{RL}}$ output provides a logic low when either reverse loop battery or reverse loop current is detected (tip lead voltage negative with respect to ring lead).

Service Out detect - the $\overline{\text{SO}}$ output will detect the loop current between 5mA to 10.13 mA as "out of service" during the DC termination. The Central Office applies -48V battery to the line but limits the loop current to this range to indicate the line is out of service. $\overline{\text{FL}}$ and $\overline{\text{RV}}$ outputs will not go low if the loop current is less than 12.5mA.

Line Impedance

The input impedance of the MH88634K is 600 ohms. The network balance is also set at 600 ohm to maximize the Transhybrid Balance.

Transmit and Receive Gain

Transmit Gain (Tip-Ring) is set at 0dB and Receive Gain (Rx to Tip-Ring) is set at -2dB.

DC Electrical Characteristics†

		Characteristics	Sym	Min	Typ*	Max	Units	Test Conditions
1		Supply Current	I_{DD} I_{EE}	0.5 0.5		13 13	mA mA	
2		Power Consumption	PC			137	mW	V_{BAT} not connected
3	\overline{FL} \overline{RL} \overline{SO} \overline{RV}	Low Level Output Voltage High Level Output Voltage	V_{OL} V_{OH}			0.5 3.7	V V	$I_{OL} = 4mA$ $I_{OH} = 100\mu A$
4	LRD	Sink Current, Relay to V_{DD} Clamp Diode Current	I_{OL} I_{CD}	100 150			mA mA	$V_{OL} = 0.35V$ not continuous
5	LRC	Low Level Input Voltage High Level Input Voltage	V_{IL} V_{IH}			0.8	V V	
6		High Level Input Current Low Level Input Current	I_{IH} I_{IL}			40 40	μA μA	$V_{IH} = 5.0V$

* Typical figures are at 25°C with nominally +5V supplies and are for design use only.

† DC Electrical Characteristics are over recommended operating conditions unless otherwise stated.

Absolute Maximum Ratings* Voltages are with respect to AGND

	Parameters	Sym	Min	Max	Units
1	DC Supply Voltages	V_{BAT} V_{DD} V_{EE}	0 -0.3 0.3	-60 7 -7	V V V
2	DC Ring Relay Voltage	V_{VRLY}	-0.3	7	V
3	Storage Temperature	T_S	-55	+125	°C

* Exceeding these values may cause permanent damage. Functional operation under these conditions is not implied.

Recommended Operating Conditions

	Parameters	Symbol	Min	Typ*	Max	Units	Comments
1	DC Supply Voltages	V_{DD} V_{EE}	4.75 -4.75	5.0 -5.0	5.25 -5.25	V V	
2	DC Ring Relay Voltage	V_{VRLY}		5.0	15	V	
3	Operating Temperature	T_{OP}	0		70	°C	

* Exceeding these values may cause permanent damage. Functional operation under these conditions is not implied.

Loop Electrical Characteristics*

	Characteristics	Symbol	Min	Typ [†]	Max	Units	Test Conditions
1	Ringing Voltage	VR	40	90	130	V _{rms}	
2	Ringing Frequency		16	20	33	Hz	
3	Ringer Equivalence number	REN	0.5	1	2		Dummy Ringer is 17K in series with 330nF. Type A ringing
4	Operating Loop Current		15		70	mA	
5	Operating Loop Resistance		0		1800	Ω	@ 20mA, -42.5V
6	Off-Hook DC Resistance			250	275	Ω	@ 20mA
7	Leakage Current (Tip-Ring to AGND)				10	mA	@ 1000Vac 50 or 60 Hz
8	FL Threshold Tip-Ring (On-hook) Tip-ring Current (Off-Hook)		+30 12.5		+40 15	Vdc mA	LRC = 0v LRC = 5V
9	RL Threshold Tip-Ring (On-Hook) Tip-Ring current (Off-Hook)		-30 -12.5		-40 -15	Vdc mA	LRC = 0v LRC = 5V
10	SO Detect		-10.13		-12.4	mA	V _{BAT} = -48V

* Loop Electrical Characteristics are over recommended operating conditions unless otherwise stated.

† Typical figures are at 25°C and are for design aid only.

AC Electrical Characteristics *

	Characteristics	Sym	Min	Typ [†]	Max	Units	Test Conditions
1	2-wire Input Impedance	Z _{in}		600		Ω	
2	Return Loss at 2-wire (Z _{in} = Ref = 600)	RL	20			dB	200-3400 Hz
3	Longitudinal to Metallic Balance		58 58 53			dB	200Hz 1000Hz 3.4kHz
4	Transhybrid Loss	THL	20			dB	200-3400Hz
5	Gain (voltage) 2 wire to Tx		-0.25	0	0.25	dB	1024Hz
6	Gain (Voltage) Rx to 2 wire		-2.25	-2	-1.75	dB	Spec Freq
7	Input impedance at Rx		10			kΩ	
8	Output impedance at Tx			5		Ω	
9	Signal Overload Level at 2-wire output at Tx		4.0 0.95			dBm Vrms	% THD ≤ 5% Ref 600Ω @ 20mA
10	Total Harmonic Distortion at 2-wire at Tx	THD			1.0 1.0	% %	Input 0.5V, 1kHz @ Rx Input 0.5V, 1kHz @ Tip-Ring
11	Idle Channel Noise at 2-Wire at Tx	NC			13 13	dBrc dBrc	
12	Power Supply Rejection Ratio at 2-wire and Tx	PSRR					Ripple 0.1V, 1kHz
	V _{DD}			30		dB	
	V _{EE}			30		dB	

* AC Electrical Characteristics are over recommended operating conditions unless otherwise stated.

† Typical figures are at 25°C and are for design aid only.

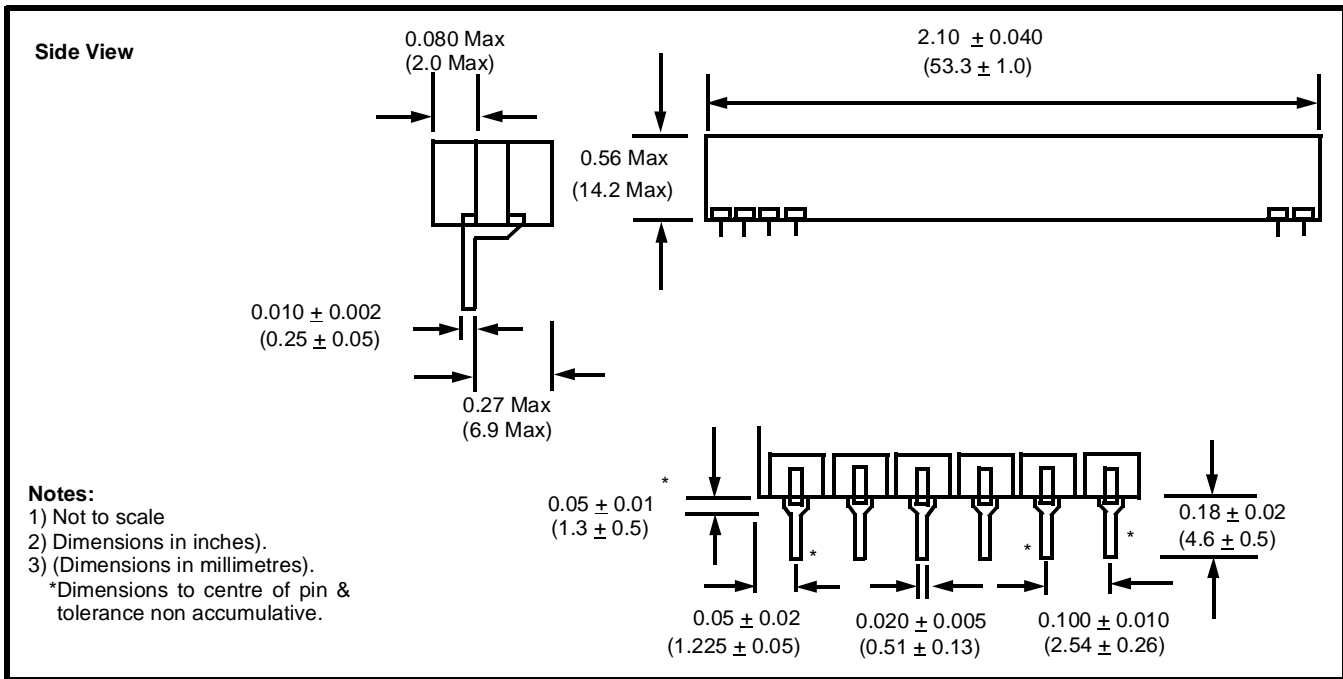

Figure 3 - Mechanical Data

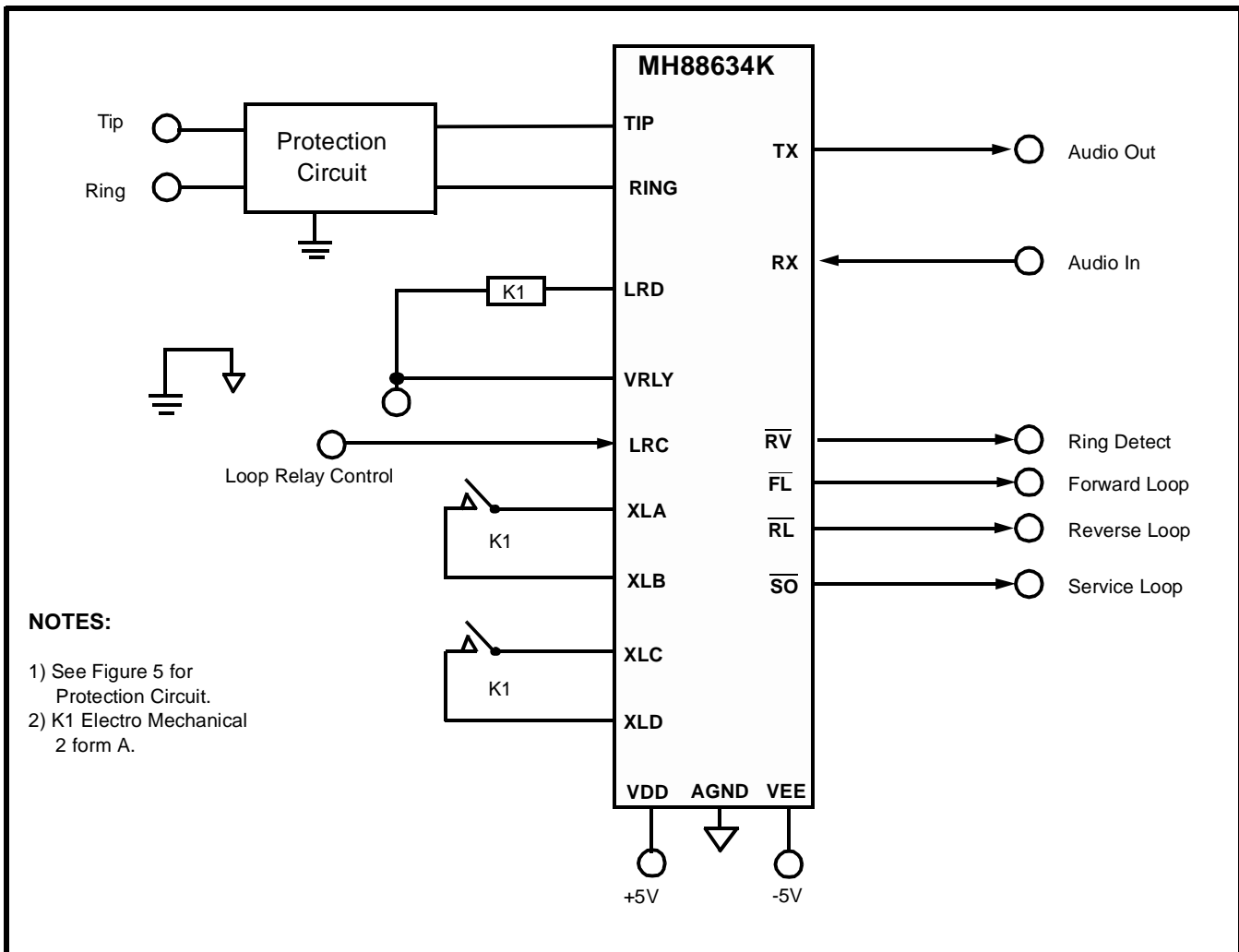

Figure 4 - Typical LS-GS Application Circuit

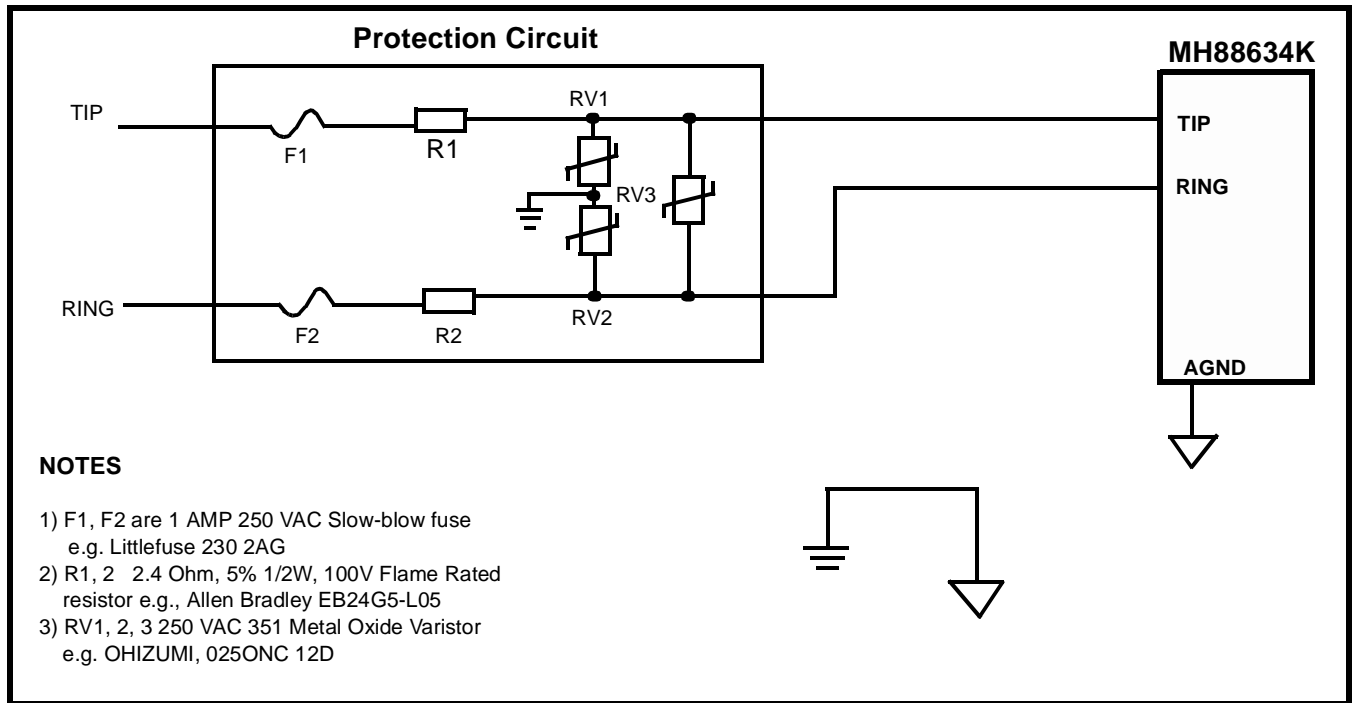

Figure 5 - External Application Circuit

Notes: