

# 2-channel reversible motor driver

## BA6259N

The BA6259N incorporates two reversible-motor drivers.

●Features

- 1) Two reversible-motor driver circuits are built in.
- 2) Built-in thermal shutdown circuit.
- 3) SIP10pin package.

●Block diagram

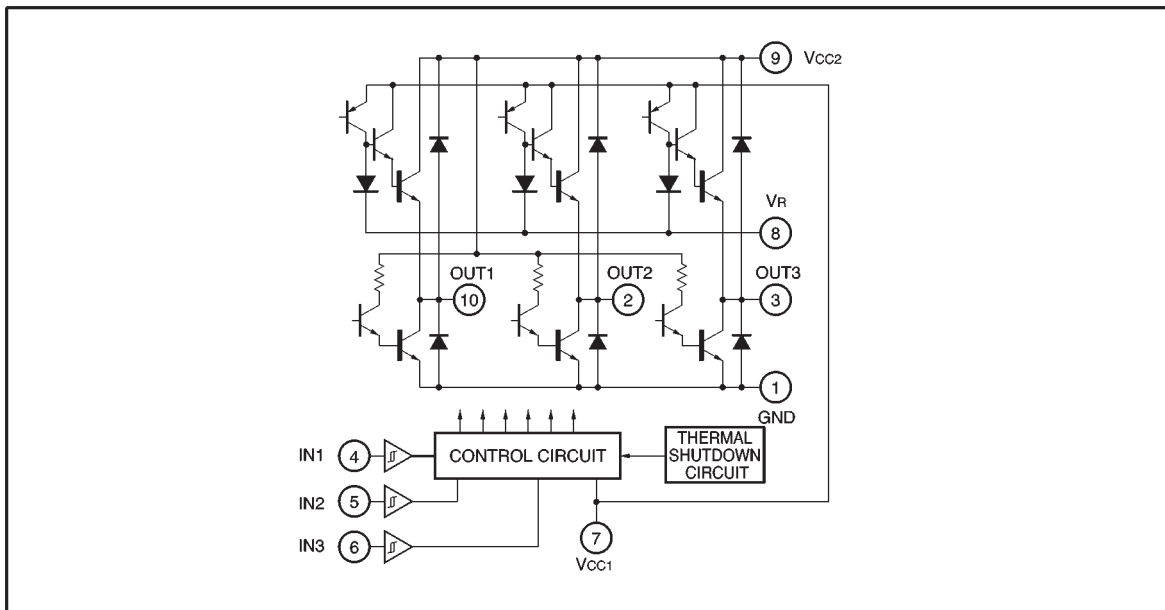

●Absolute maximum ratings (Ta = 25°C)

Parameter	Symbol	Limits	Unit
Power supply voltage	V <sub>CC1</sub>	20	V
	V <sub>CC2</sub>	25	V
Power dissipation	P <sub>d</sub>	1000*1	mW
Operating temperature	T <sub>opr</sub>	-20~+75	°C
Storage temperature	T <sub>stg</sub>	-50~+125	°C
Input voltage	V <sub>IN</sub>	-0.2~+6	V
Output current	I <sub>o</sub>	1.0*2	A

\*1 Reduced by 10 mW for each increase in Ta of 1°C over 25°C.

\*2 50ms pulse with a duty ratio of 1 / 50.

●Electrical characteristics (unless otherwise noted, Ta = 25°C and Vcc = 12V)

Parameter	Symbol	Min.	Typ.	Max.	Unit	Conditions
Operating voltage	V <sub>CC1</sub>	8	—	18	V	V <sub>CC2</sub> < V <sub>CC1</sub>
	V <sub>CC2</sub>	8	—	18	V	
Output reference voltage (pin 8)	V <sub>R</sub>	8	—	18	V	V <sub>R</sub> and V <sub>CC2</sub> are directly connected
Current dissipation	I <sub>CC</sub>	—	12	24	mA	R <sub>L</sub> =∞, 4, 5, 6pin ; "L"
Input low level voltage	V <sub>IL</sub>	—	—	1.0	V	Pins 4, 5
Input high level voltage	V <sub>IH</sub>	3.5	—	—	V	Pins 4, 5
Output low level voltage (pins 2, 3, 10)	V <sub>OL</sub>	—	0.3	0.5	V	I <sub>o</sub> =0.15A
Output high level voltage (pins 2, 3, 10)	V <sub>OH</sub>	11.0	11.3	—	V	Pins 8 and 9 are directly connected, I <sub>o</sub> = 0.15 A

●Input / output truth table

Input			Output		
4pin (IN)	5pin (IN)	6pin (IN)	10pin (OUT)	2pin (OUT)	3pin (OUT)
L	L	L	OPEN	OPEN	OPEN
		H			
H	L	L	H	L	OPEN
		H	L	H	OPEN
L	H	L	H	OPEN	L
		H	L	OPEN	H
H	H	L	L	L	L
		H			

\* HIGH level input is 3.5 V or more.  
 LOW level input is 1.0 V or less.

●Application example

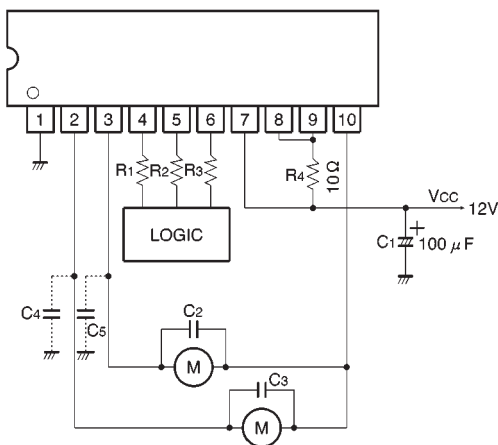

Fig.1

C<sub>2</sub>, C<sub>3</sub> : Capacitors for preventing parasitic oscillation. Though the optimum capacitance depends on such PCB arrangement factors as the power supply circuit, motor characteristics, and conductor foil patterns, a range of 0.01 ~ 1μF is recommended.

C<sub>4</sub>, C<sub>5</sub> : Capacitors for preventing parasitic oscillation. They may or may not be required, depending on the PCB arrangement. A capacitance range of 0.01 ~ 10μF is recommended.

### ● Control pin equivalent circuit

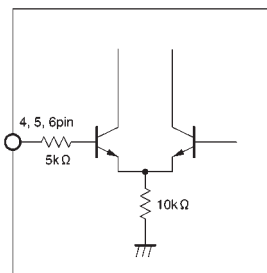

Fig.2

### ● Operation notes

- (1) Use the BA6259N with  $V_R$  (pin 8) short-circuited to  $V_{CC2}$  (pin 9). The  $V_{CC2}$  potential should be lower than the  $V_{CC1}$  potential. Under these conditions, the IC provides a HIGH level output voltage of 11.3V (typical,  $V_{CC2}=12V$ ). Because a single transistor is used for the low-side output stage, the LOW level output voltage is further lowered. This results in a wide range of motor drive voltage.
- (2) Though the IC input pins can be directly connected with MOS output pins, it is recommendable to connect resistors of a few kilohms to dozens of kilohms between the pins for the sake of pin protection.

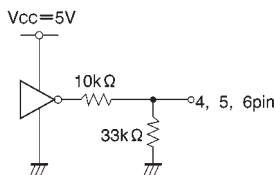

Fig.3

(3) Due to the effects of capacitors  $C_2 \sim C_5$ , the motor that is not being driven could be momentarily driven during mode switching. Check for this problem when designing your application.

(4) It is recommendable to arrange your design so that voltage rises at  $V_{CC1}$  prior to  $V_{CC2}$  when turning on the power, and voltage falls at  $V_{CC1}$  after  $V_{CC2}$  when turning off the power.

(5) Thermal shutdown circuit

When the thermal shutdown circuit is activated, the output is left OPEN. The circuit is activated when the IC junction temperature rises above  $170^\circ\text{C}$ . The temperature difference between the activation and deactivation settings is about  $30^\circ\text{C}$ .

(6) The quality of these products have been carefully checked; however, use of the products with applied voltages, operating temperatures, or other parameters that exceed the absolute maximum rating given may result in the damage of the IC and the product it is used in. If the IC is damaged, the short mode and open modes cannot be specified, so if the IC is to be used in applications where parameters may exceed the absolute maximum ratings, then be sure to incorporate fuses, or other physical safety measures.

(7) Input pins

Voltage should never be applied to the input pins when the  $V_{CC}$  voltage is not applied to the IC. Similarly, when  $V_{CC}$  is applied, the voltage on each input pin should be less than  $V_{CC}$  and within the guaranteed range for the electrical characteristics.

(8) Back-rush voltage

Depending on the ambient conditions, environment, or motor characteristics, the back-rush voltage may fluctuate. Be sure to confirm that the back-rush voltage will not adversely affect the operation of the IC.

**(9) Large current line**

Large currents are carried by the motor power supply and motor ground for these ICs.

Therefore, the layout of the pattern of the PC board and the constants of certain parameters for external components, such as the capacitor between the power supply and ground, may cause this large output current to flow back to the input pins, resulting in output oscillation or other malfunctions. To prevent this, make sure that the PC board layout and external circuit constants cause no problems with the characteristics of these ICs.

**(10) Power dissipation**

The power dissipation will fluctuate depending on the mounting conditions of the IC and the ambient environment. Make sure to carefully check the thermal design of the application where these ICs will be used.

**(11) Power consumption**

The power consumption by the IC varies widely with the power supply voltage and the output current. Give full consideration to the power dissipation rating and the thermal resistance data and transient thermal resistance data, to provide a thermal design so that none of the ratings for the IC are exceeded.

**(12) ASO**

Make sure that the output current and supply voltage do not exceed the ASO values.

**(13) Precautions for input mode switching**

To ensure reliability, it is recommended that the mode switching for the motor pass once through the open mode.

**(14) In-rush current**

There are no circuits built into these ICs that prevent in-rush currents. Therefore, it is recommended to place a current limiting resistor or other physical countermeasure.

**(15) Factors regarding the thermal, power supply, and motor conditions**

If the potential of the output pin sways greatly and goes below the potential of ground, the operation of the IC may malfunction or be adversely affected. In such a case, place a diode between the output and ground, or other measure, to prevent this.

●Electrical characteristic curves

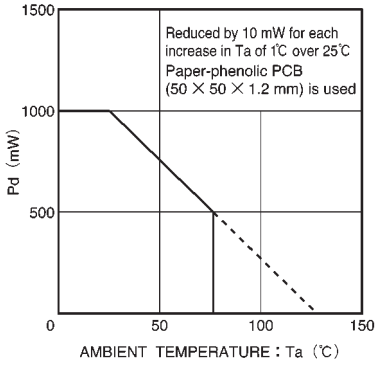

Fig.4 Thermal derating curve

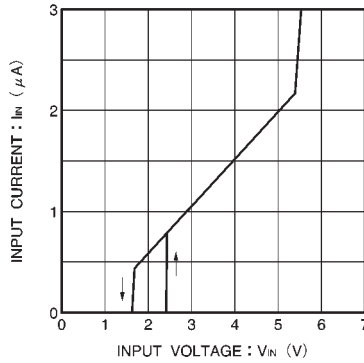

Fig.5 Input voltage vs. input current

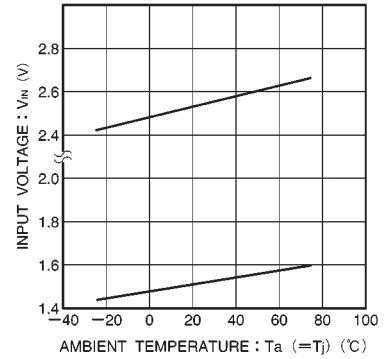

Fig.6 Input voltage vs. ambient temperature

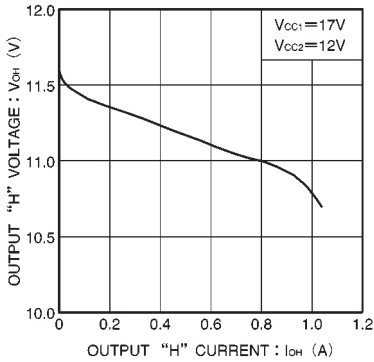

Fig.7 Output high level voltage vs. output current

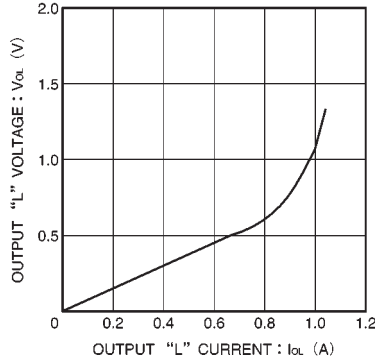

Fig.8 Output low level voltage vs. output current

●External dimensions (Units: mm)

