

SPINDLE MOTOR AND 1CH ACTUATOR DRIVER

PIN DESCRIPTION

Pin No.	Symbol	Function	Pin No.	Symbol	Function
①	ECR	The reference voltage for EC	⑳	Vcc2	12V supply voltage
②	EC	Motor speed control	㉑	Rs	Motor current sense
③	S/S	Start / Stop for spindle driver	㉒	Cl	Phase Compensation
④	BRS	Reverse torque mode select	㉓	TP	Test Note1
⑤	FGS	FG pulse select	㉔	W	Motor drive output W
⑥	FG	Frequency generator output	㉕	V	Motor drive output V
⑦	Vcc1	5V supply voltage	㉖	U	Motor drive output U
⑧-⑭	GND	GND	㉗-㉛	GND	GND
⑮	HB	Bias for Hall Sensor	㉜	OUT+	Non-inverted output of actuator driver
⑯	Hu+	Hu+ Sensor amp. input	㉝	VDD-	GND of actuator driver
⑰	Hu-	Hu- Sensor amp. input	㉞	VDD+	Power supply of actuator driver
⑱	Hv+	Hv+ Sensor amp. input	㉟	OUT-	Inverted output of actuator driver
⑲	Hv-	Hv- Sensor amp. input	㊱	MUTE	Mute of actuator driver
㉑	Hw+	Hw+ Sensor amp. input	㊲	IN+	Non-inverted input of actuator driver
㉒	Hw-	Hw- Sensor amp. input	㊳	IN-	Inverted input of actuator driver

*Pull-up resistors (10k Ω) are included in the circuits connected to pin[FG].

*Note1. The pin TP is test terminal. Please make an open the pin TP.

ABSOLUTE MAXIMUM RATING (Ta=25°C)

Symbol	Parameter	Conditions	Rating	Unit
Rs	Motor supply voltage	㉑ pin	15	V
Vcc2	Power supply 2 voltage	㉒ pin	15	V
Vcc1	Power supply 1 voltage	⑦ pin	7.0	V
Vdd+	Power supply 3 voltage	㉞ pin	15	V
Io1	SPM Output current	Note 2	1.2	A
Io2	ATC Output Current	Note 2	0.7	A
VH(c)	Sensor amp. Differential input range	⑮-㉒ pins	4.5	V
Vin	Maximum voltage of input terminals	①, ②, ③, ④, ⑤, ⑮-㉒, ㉕ pin	0-Vcc1	V
		㉑, ㉒, ㉓ pin	0-Vcc2	V
Pt	Power dissipation	Free Air	1.2	W
K θ	Thermal derating	Free Air	9.6	mW/°C
Tj	Junction temperature		150	°C
Topr	Operating temperature		-20+75	°C
Tstg	Storage temperature		-40+125	°C

*Note2 ; The ICs must be operated within the Pt (power dissipation) or the area of safety operation.

*Note3 ; The ㉑ pin[TP] is a test terminal. Please make open this terminal.

*Note4 ; Please don't connect directly the external power supply to the ㉔, ㉕, ㉖, ㉜, ㉝, ㉞, ㉟, ㊱, ㊲, ㊳ pin.

RECOMMENDED OPERATING CONDITIONS

Symbol	Parameter	Limits			Unit
		Min.	Typ.	Max.	
Vcc1	Power supply 1	4.5	5.0	5.5	V
Vcc2	Power supply 2	4.5	12.0	13.2	V
Vdd+	Power supply 3	4.5	12.0	13.2	V
Io1	SPM Output drive current	—	—	700	mA
Io2	ACT Output drive current	—	—	700	mA

ELECTRICAL CHARACTERISTICS

(VCC1=5V, VCC2=12V, VDD+=5V, VDD-=GND, Ta=25°C unless otherwise noted.)

Symbol	Parameter	Conditions	Limits			Unit
			Min.	Typ.	Max.	
Isleep	Sleep Mode Supply current	Vcc1 & Vcc2 pin total Current (at S/S pin, MUTE pin low or open)	—	—	10	μA
Icc	Supply current	Vcc1 & Vcc2 pin total Current (EC=ECR=1.65V) [S/S pin, MUTE pin High]	—	19	28	mA
Vsat	Saturation voltage	Top and Bottom saturation voltage.(Load current:500mA)	—	1.2	1.9	V
ECdead-	Control voltage dead zone	EC<ECR	-60	-30	0	mV
ECdead+		EC>ECR	0	+30	+60	
ECR	Reference voltage Input range	① pin(it is possible to input 0 to 5V)	0	1.65	3.3	V
EC	Control voltage Input range	② pin(it is possible to input 0 to 5V)	0	1.65	3.3	V
Gio	Control gain	Io=Gio/Rsense [A/V]	0.34	0.4	0.46	V/V
Vlim	Control limit	Ilim=Vlim/Rsense [A]	0.27	0.3	0.33	V
VH com	Hall sensor amp common mode input range	⑯-⑳ pins	1.3	—	Vcc1-1.3	V
VHmin	Hall sensor amp. input signal level	㉓-㉔ pins	60	120	—	mVp-p
VHb	Hall bias terminal output voltage	Load current (IHb)=10mA.	0.6	0.85	1.2	V
IHb	Hall bias terminal sink current		—	—	30	mA
Von	Motor start voltage	[S/S]pin input voltage when it starts up the motor. *The IC is in the active condition. *The hall bias is available.	2.0	—	—	V
Voff	Motor stop voltage	[S/S]pin input voltage when it stops the motor. *The IC is in the sleep condition. *The hall bias is off.	—	—	0.8	V
Vih1	BRS input high voltage	BRS input voltage that the short braking is selected when the reverse torque.	3.6	—	—	V
ViM	BRS input middle voltage	BRS input voltage that the free run is selected when the reverse torque.	1.6	—	2.2	V
Vil1	BRS input low voltage	BRS input voltage that the reverse braking is selected when the reverse torque.	—	—	0.8	V

*Note3. The ViM is the limit in case of external voltage input control. The free run mode is selected when the BRS pin is open, too.

M56786FP

SPINDLE MOTOR AND 1CH ACTUATOR DRIVER

ELECTRICAL CHARACTERISTICS

(VCC1=5V, VCC2=12V, VDD+=5V, VDD-=GND, Ta=25°C unless otherwise noted.)

Symbol	Parameter	Conditions	Limits			Unit
			Min.	Typ.	Max.	
V _{iL2}	Logic input Low voltage	[FGS] input voltage when it is LOW.	—	—	0.8	V
V _{oL}	[FG] pin output low voltage	at I _o current=1mA	—	—	0.5	V
V _{iH2}	Logic input high voltage	[FGS] input voltage when it is HIGH.	2.0	—	—	V

ELECTRICAL CHARACTERISTICS

(VCC1=5V, VCC2=12V, VDD+=5V, VDD-=GND, Ta=25°C unless otherwise noted.)

Symbol	Parameter	Conditions	Limits			Unit
			Min.	Typ.	Max.	
V _{sat2}	ACT Saturation voltage	Top and Bottom saturation voltage. Load current 0.5A (bootstrap)	—	0.7	1.0	V
V _{off2}	output offset voltage	IN(+)= IN(-)= 1.65V	-47	—	47	mV
Gain	Voltage Gain between input and output	{OUT(+)-OUT(-)} (IN(+) - IN(-))	7.2	8.0	8.8	V/V
V _{inIN}	IN-,IN+ input voltage range	V _{cc2} = 12 V	0	—	8.0	V
		V _{cc2} = 5 V V _{DD+} = 5 V	0	—	3.0	V
I _{inIN}	IN-,IN+ input current	IN(+) = IN(-) = 1.65V	-2	—	0	μA
V _{mute-on}	Mute-on voltage	Mute-on	—	—	0.8	V
V _{mute-off}	Mute-off voltage	Mute-off	2.0	—	—	V
I _{mute}	Mute terminal input current	Mute terminal input current (at 5V input voltage)	—	—	250	μA

THERMAL CHARACTERISTICS

(VCC1=5V, VCC2=12V, VDD+=5V, VDD-=GND, Ta=25°C unless otherwise noted.)

Symbol	Parameter	Function start temperature of IC			Function stop temperature of IC			Unit
		Min.	Typ.	Max.	Min.	Typ.	Max.	
TSD	Thermal Shut Down	—	165	—	—	125	—	°C

THE RELATIONSHIP WITH I/O CONTROL AND THE BRAKING MODE

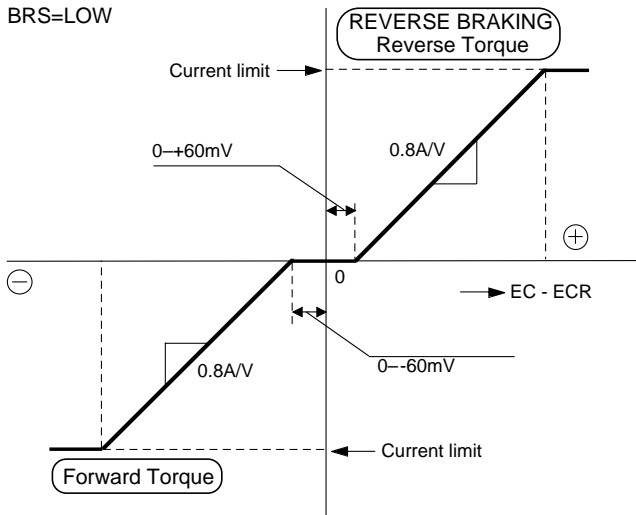

Figure 1.

The braking mode is selected flexibly by using the BRS terminal. The relationship between the EC-ECR (the difference between EC<control voltage> and ECR<reference voltage>) and the torque is shown in Figure 1,2 and 3.

The current gain is 0.8A/V(at sensing resistor:0.5ohm) in forward torque directions, and the dead zone is from 0mV to 60mV. When the reverse brake mode(BRS=Lo) is selected, the coil current gain under the reverse torque control is the same with in forward torque directions.

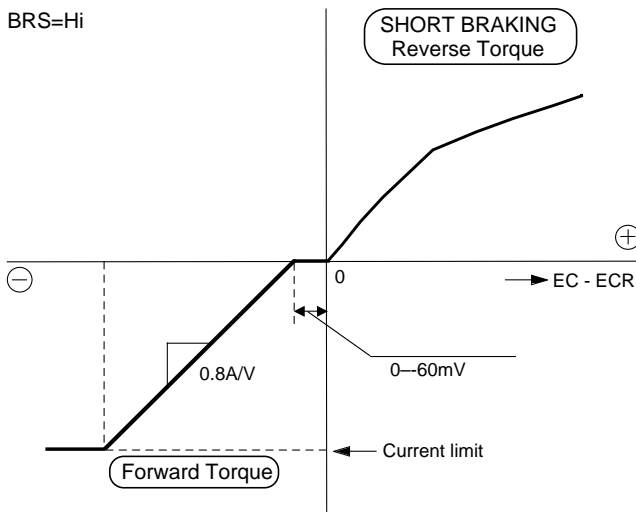

Figure 2.

When the short brake mode(BRS=Hi) is selected, the coil current under the reverse torque control depends on the back emf. and the coil resistance.

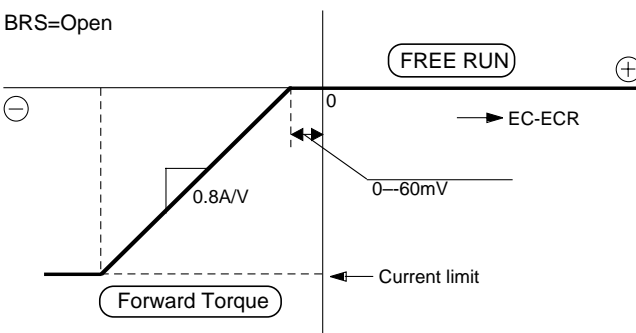
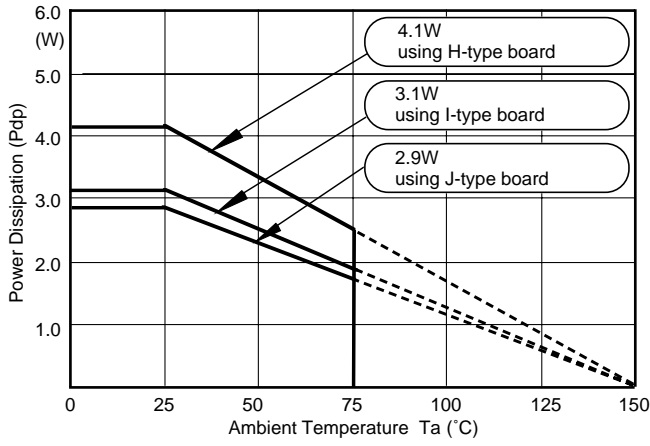

Figure 3.

When the free run mode(BRS=open) is selected, the coil current under the reverse torque control (EC-ECR>0) becomes zero and in free run situation.

THERMAL DERATING



This IC's package is POWER-SSOP, so improving the board on which the IC is mounted enables a large power dissipation without a heat sink.

For example, using an 1 layer glass epoxy resin board, the IC's power dissipation is 2.9W at least. And it comes to 4.1W by using an improved 2 layer board.

The information of the H, I, J type board is shown in the board information.

HALL AMPLIFIER INPUT AND COMMUTATION

The relationship between the hall amplifier inputs voltage and the motor current outputs is shown in Figure 4.

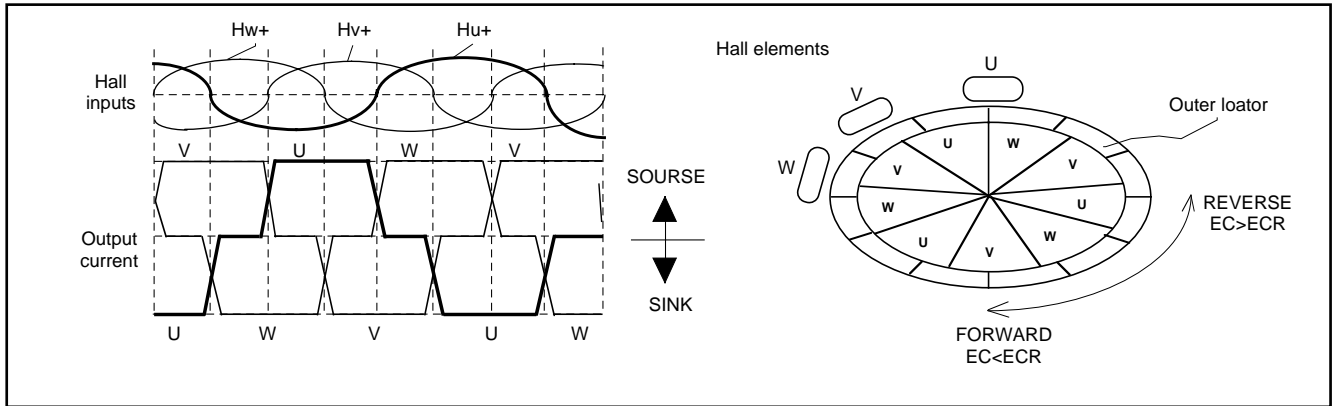

Figure 4.

BRAKING MODE SELECT FUNCTION

Braking mode select [BRS] pin	
HIGH	SHORT BRAKE
OPEN	FREE RUN
LOW	REVERSE BRAKE

Figure 5.

It is possible to select three kinds of mode [the reverse braking, the short braking and the free run] in reverse torque by logic control using the BRS terminal.

Figure 5 shows the function table of the braking mode select. It is the reverse braking when BRS is LOW, the short braking when BRS is HIGH and the free run when BRS is OPEN.

FG FUNCTION

FG pulse select (FGSpin)	
LOW or OPEN	HIGH
NX1 pulse	NX3 pulse

Figure 6.

It is possible for user to switch the output pulse numeric by external logic control using FG pulse select terminal [FGS].

Figure 6 shows the FG pulse select function. The FG pin outputs the square pulse signal synchronizing with the hall inputs [Hv+ and Hv-] timing when FGS=LOW or OPEN. When FGS=HIGH, it outputs the square pulse signal of 3 times. The FG pin is pulled-up to Vcc1 by an internal resistor [typ. 10Kohm].

SLEEP MODE FUNCTION and MUTE FUNCTION

S/S	MUTE	Spindle Hall bias	Actuator CIRCUIT	BIAS CIRCUIT	TSD CIRCUIT
H	H	ON	ON	ON	ON
H	L, OPEN	ON	OFF	ON	ON
L, OPEN	H	OFF	ON	ON	ON
L, OPEN	L, OPEN	OFF	OFF	OFF	OFF

Figure 7.

This IC has the S/S terminal (S/S) for ON/OFF of the Spindle motor drive and the MUTE terminal (MUTE) for ON/OFF of the actuator drive.

It is possible to control ON / OFF of each circuit (SPM, Actuator) by external logic inputs.

The figure 7 shows its function. In case of both S/S and MUTE is LOW or OPEN, the bias of all circuit becomes OFF[Current is zero].

Therefore, this mode is available in order to reduce the power dissipation when the waiting mode.

I/O CHARACTERISTICS of ACTUATOR DRIVE PART

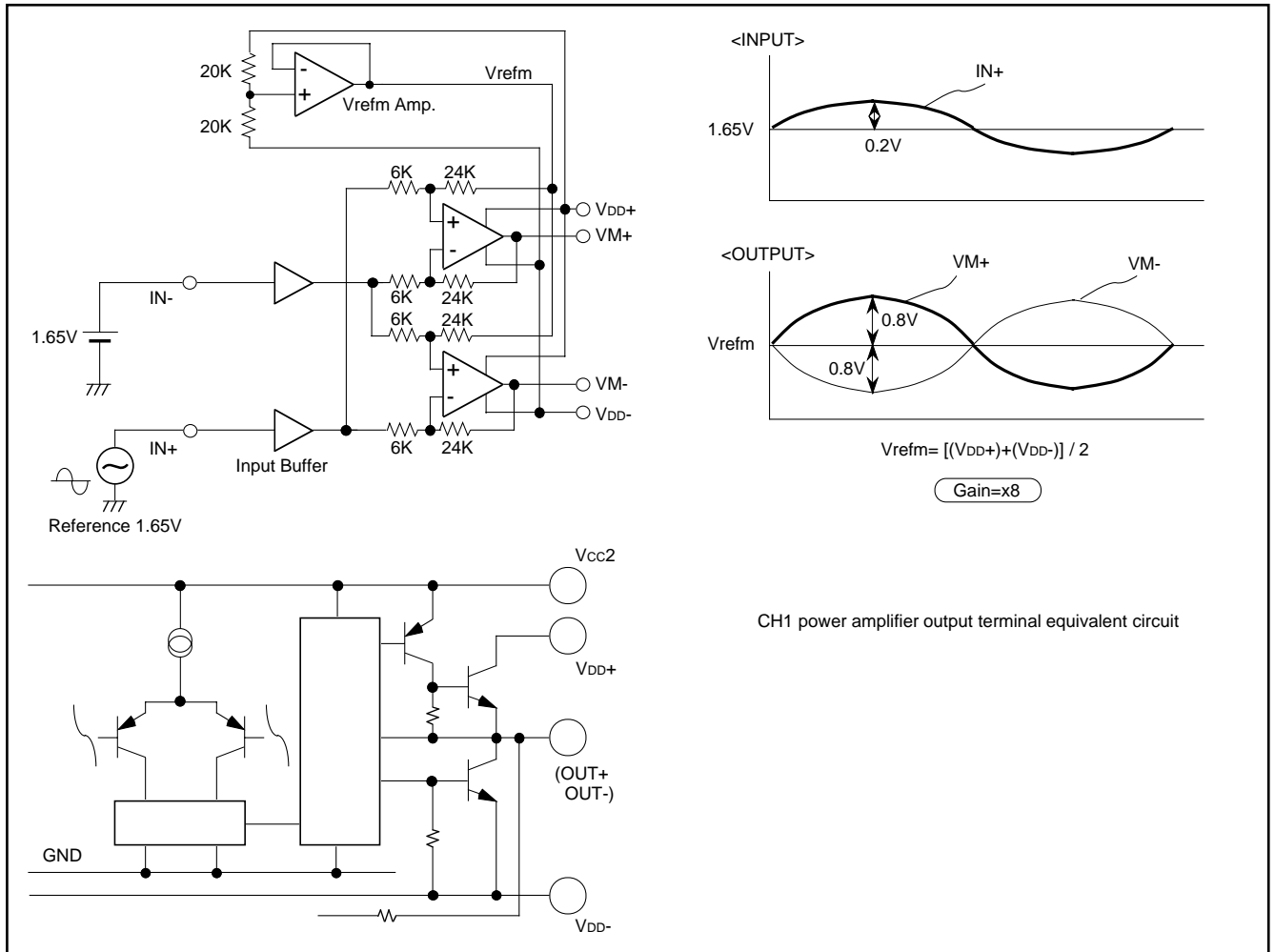
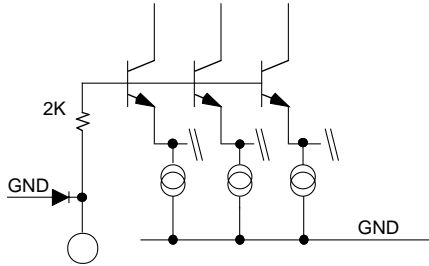

Figure 8.

The power amplifiers of CH1 is shown in Figure 8. The power supplies is VDD+ and VDD-. Generally, the VDD- pin is connected to GND(0V). Also, it is possible to be connected to other power supply larger than 0 volts (ex:5V). The source side of the power amplifier output stage consists of a PNP and a NPN. The emitta of the PNP is connected to Vcc2. So, the power of the PNP supplies can be adjusted externally.

I/O terminal Equivalent circuit

(1) Hall input amplifier
I/O terminal equivalent circuit
(Hu+, Hu-, Hv+, Hv-, Hw+, Hw-)



(2) IN+, IN-, EC, ECR input terminal equivalent circuit

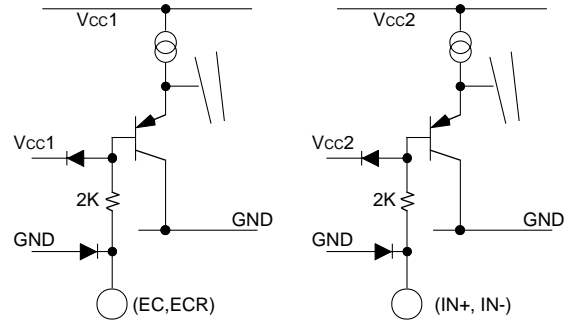

(3) FG output terminal equivalent circuit

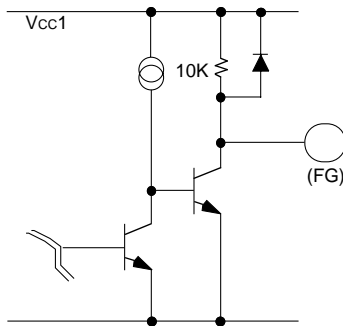

(4) HB output terminal equivalent circuit

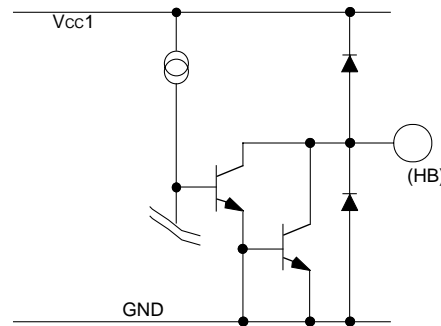

(5) BRS input terminal equivalent circuit

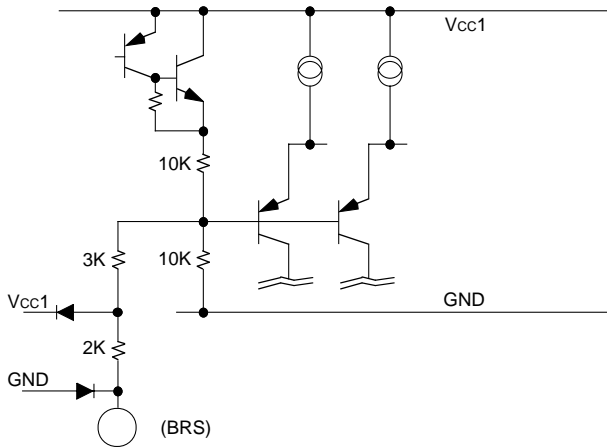

(6) S/S, MUTE, FGS input terminal equivalent circuit

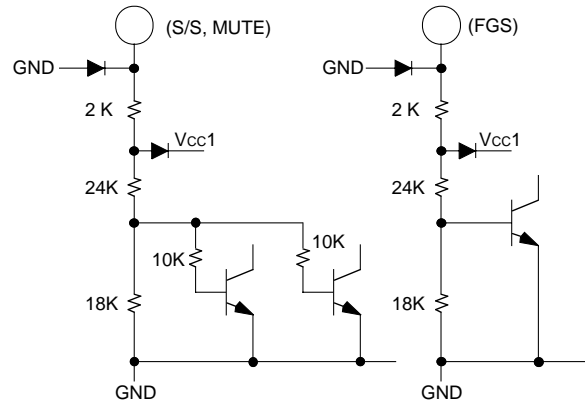

(7) Spindle driver output stage equivalent circuit

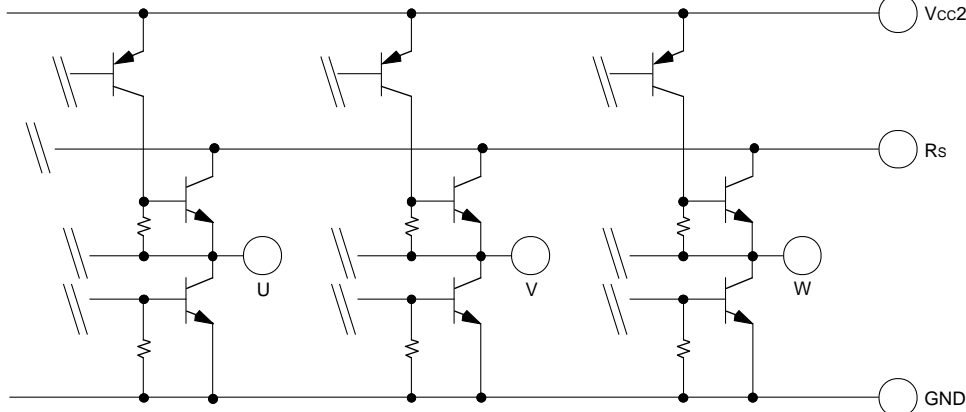

M56786FP

SPINDLE MOTOR AND 1CH ACTUATOR DRIVER

APPLICATION CIRCUIT

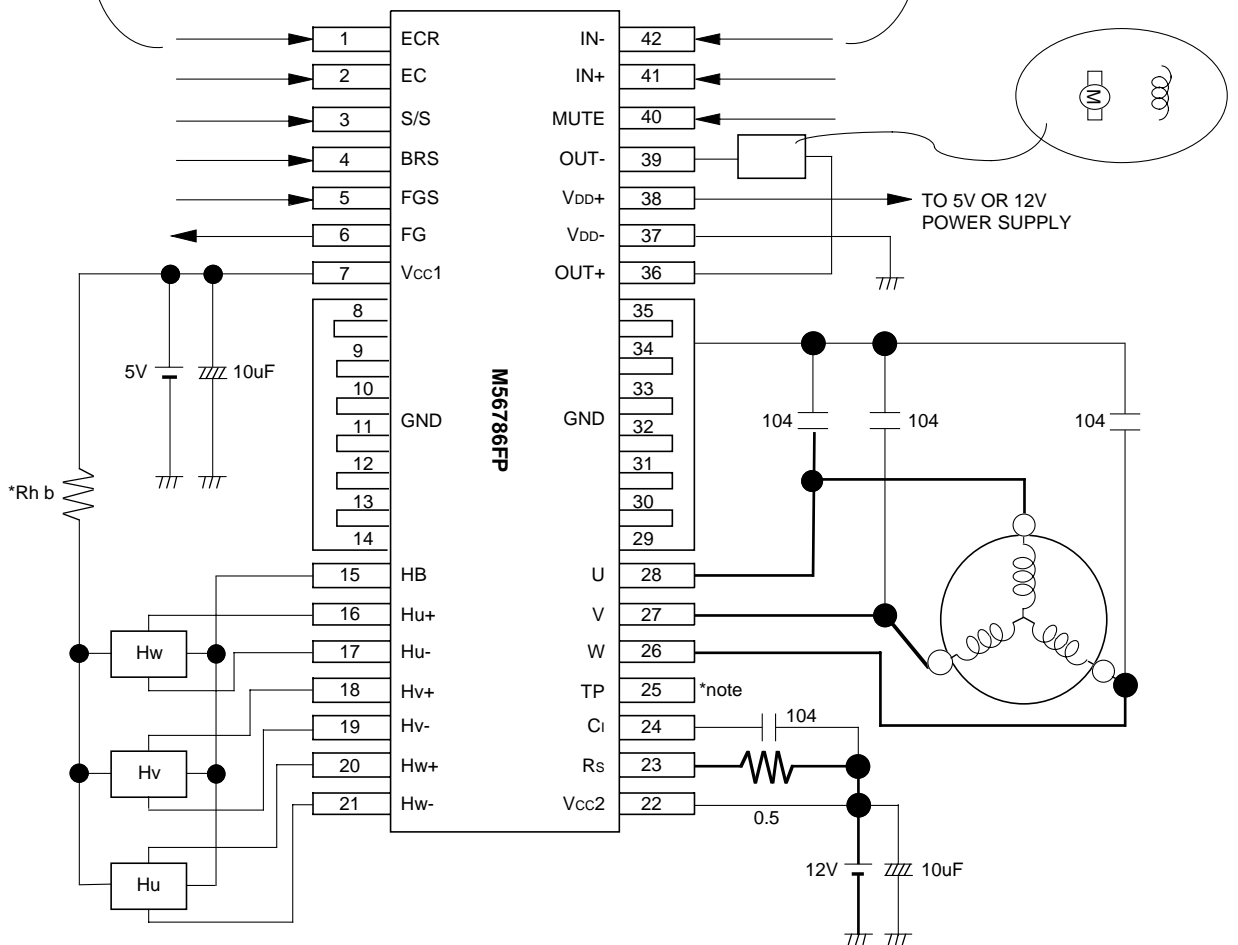
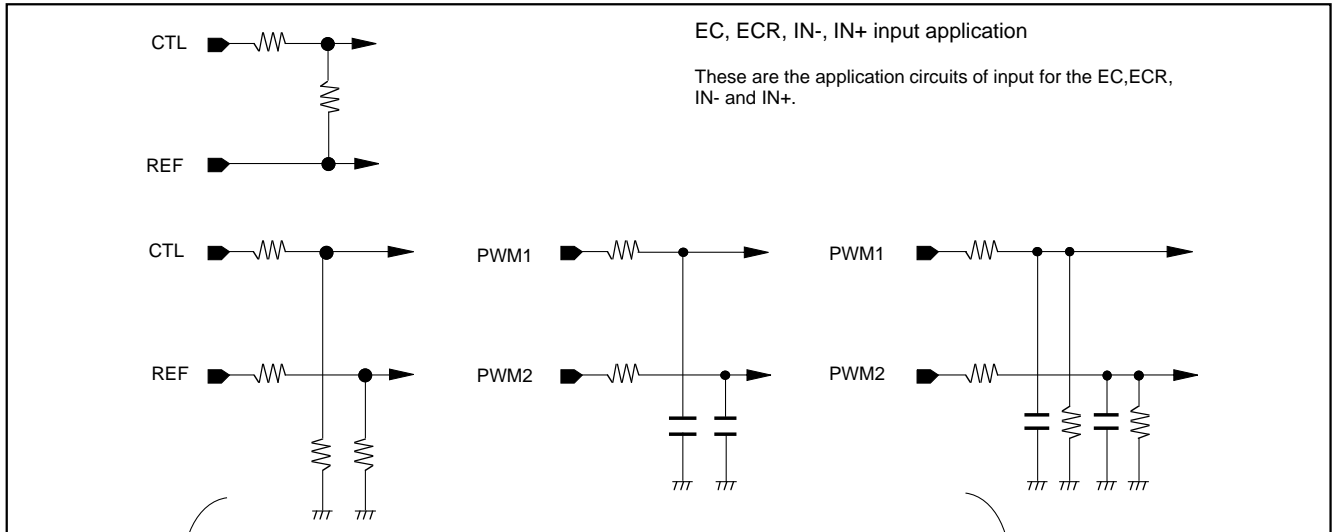

*The Rh b is a resistor in order to adjust the hall output voltage. Please fix as to be $\pm 100\text{--}130\text{mV}$ for hall output voltage.

The 25 pin (TP) is test terminal ! Please make an open this terminal !