

4-BIT SINGLE CHIP MICROCOMPUTER

DESCRIPTION

The μ PD75P238 is a version of the μ PD75238 in which the on-chip mask ROM is replaced by one-time PROM or EPROM.

The one-time PROM version can be written to once only, and is useful for short-run and multiple device-production of sets and early start-up. Also, the EPROM version allows programs to be written and rewritten, and is thus ideal for system evaluation.

Functions are described in detail in the following User's Manual, which should be read when carrying out design work.

μ PD75238 User's Manual : IEU-731

The μ PD75P238 EPROM product does not provide a level of reliability suitable for use as a volume production product for users' devices. The EPROM product should be used solely for function evaluation in experiments of preproduction.

FEATURES

- o μ PD75238 pin compatible
- o On-chip PROM: 32640 \times 8
- o On-chip RAM: 1024 \times 4
- o Drive capability in same supply voltage range as mask version μ PD75238 (2.7 to 6.0 V)
- o Ports 4 & 5: No pull-up resistor
- o Port 7: No pull-down resistor
- o High-voltage display outputs
 - . S0 to S8 & T0 to T9 : Internal pull-down resistors
 - . S9, S16 to S23 & T10 to T15: Open-drain

Note No internal pull-up and pull-down resistor function by mask option.

USE

VCR, Audio-visual, ECR, Microwave oven

ORDERING INFORMATION

Ordering Code	Package	On-Chip ROM	Quality Grade
μ PD75P238GJ-5BG	94-pin plastic QFP(□20 mm)	One-time PROM	Standard
μ PD75P238KF	94-pin ceramic WQFN	EPROM	Standard

Please refer to "Quality grade on NEC Semiconductor Devices" (Document number IEI-1209) published by NEC Corporation to know the specification of quality grade on the devices and its recommended applications.

This manual describes common parts of One-time PROM and EPROM products as PROM.

The information in this document is subject to change without notice.

PIN CONFIGURATION (TOP VIEW)

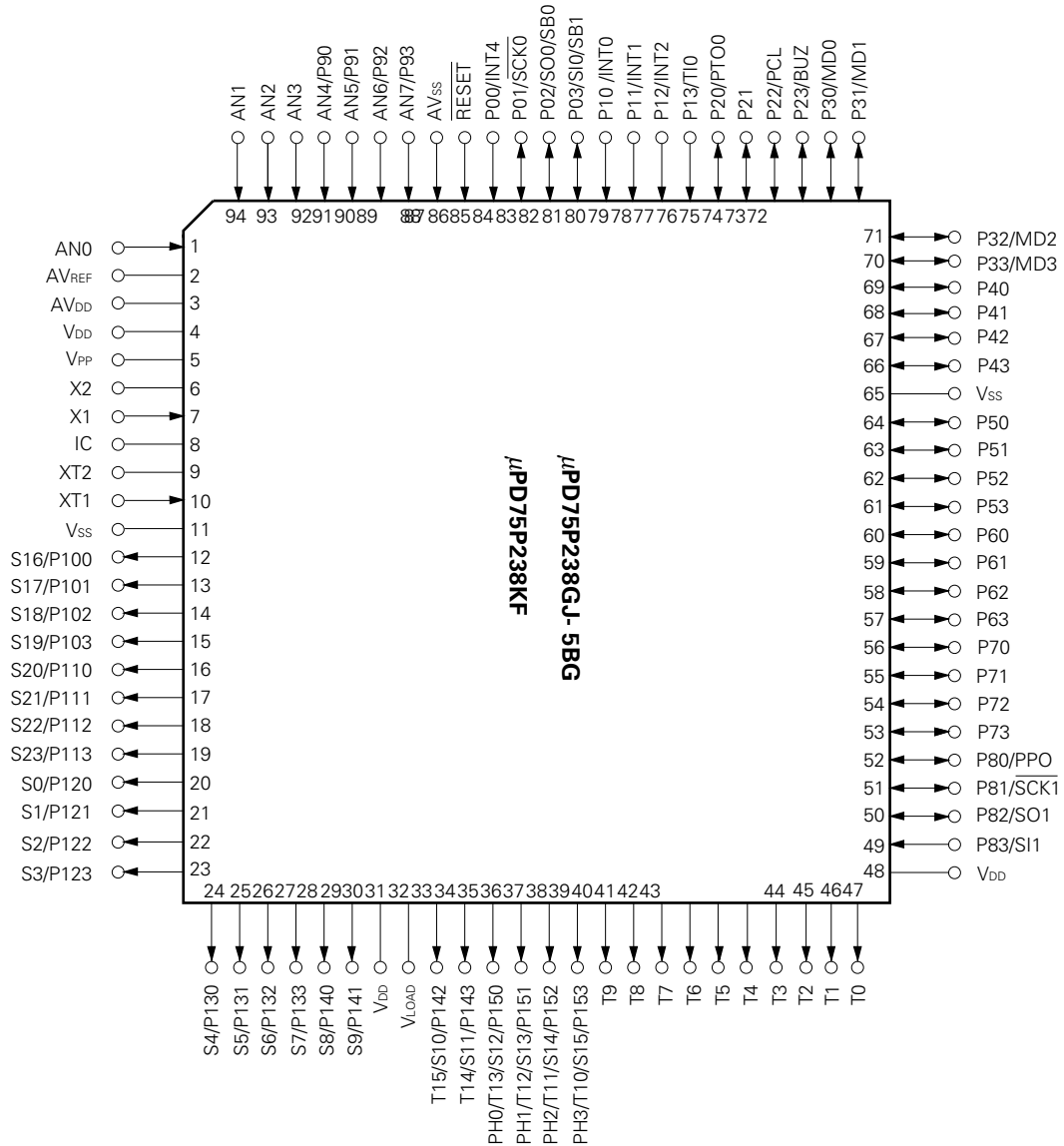

Note Ensure that power is supplied to the VDD and VSS pins (pins 4, 11, 30, 48, and 65).

Remarks IC (Internally Connected) pins should be connected directly to VSS.

PIN NAME

P00 to P03	: Port0	$\overline{\text{SCK0}}, \overline{\text{SCK1}}$: Serial Clock I/O 0, 1
P10 to P13	: Port1	SO0, SO1	: Serial Data Output 0, 1
P20 to P23	: Port2	SI0, SI1	: Serial Data Input 0, 1
P30 to P33	: Port3	SB0, SB1	: Serial Bus I/O 0, 1
P40 to P43	: Port4	INT0, INT1, INT4	: External Vectored Interrupt Input 0, 1, 4
P50 to P53	: Port5	INT2	: External Test Input 2
P60 to P63	: Port6	PPO	: Programmable Pulse Output
P70 to P73	: Port7	TI0	: Timer Input 0
P80 to P83	: Port8	PTO0	: Programmable Timer Output 0
P90 to P93	: Port9	BUZ	: Buzzer Clock
P100 to P103	: Port10	PCL	: Programmable Clock Output
P110 to P113	: Port11	AN0 to AN7	: Analog Input 0 to 7
P120 to P123	: Port12	AVREF	: Analog Reference Voltage
P130 to P133	: Port13	AVDD	: Analog V _{DD}
P140 to P143	: Port14	AVSS	: Analog V _{SS}
P150 to P153	: Port15	X1, X2	: Main System Clock Oscillation 1, 2
PH0 to PH3	: PortH	XT1, XT2	: Subsystem Clock Oscillation 1, 2
T0 to T15	: Digit Output	$\overline{\text{RESET}}$: Reset
S0 to S23	: Segment Output	V _{PP}	: Programming Power Supply
V _{DD}	: Positive Power Supply	MD0 to MD3	: Mode Selection 0 to 3
V _{SS}	: Ground	IC	: Internally Connected
V _{LOAD}	: Power Supply for FIP Driver		

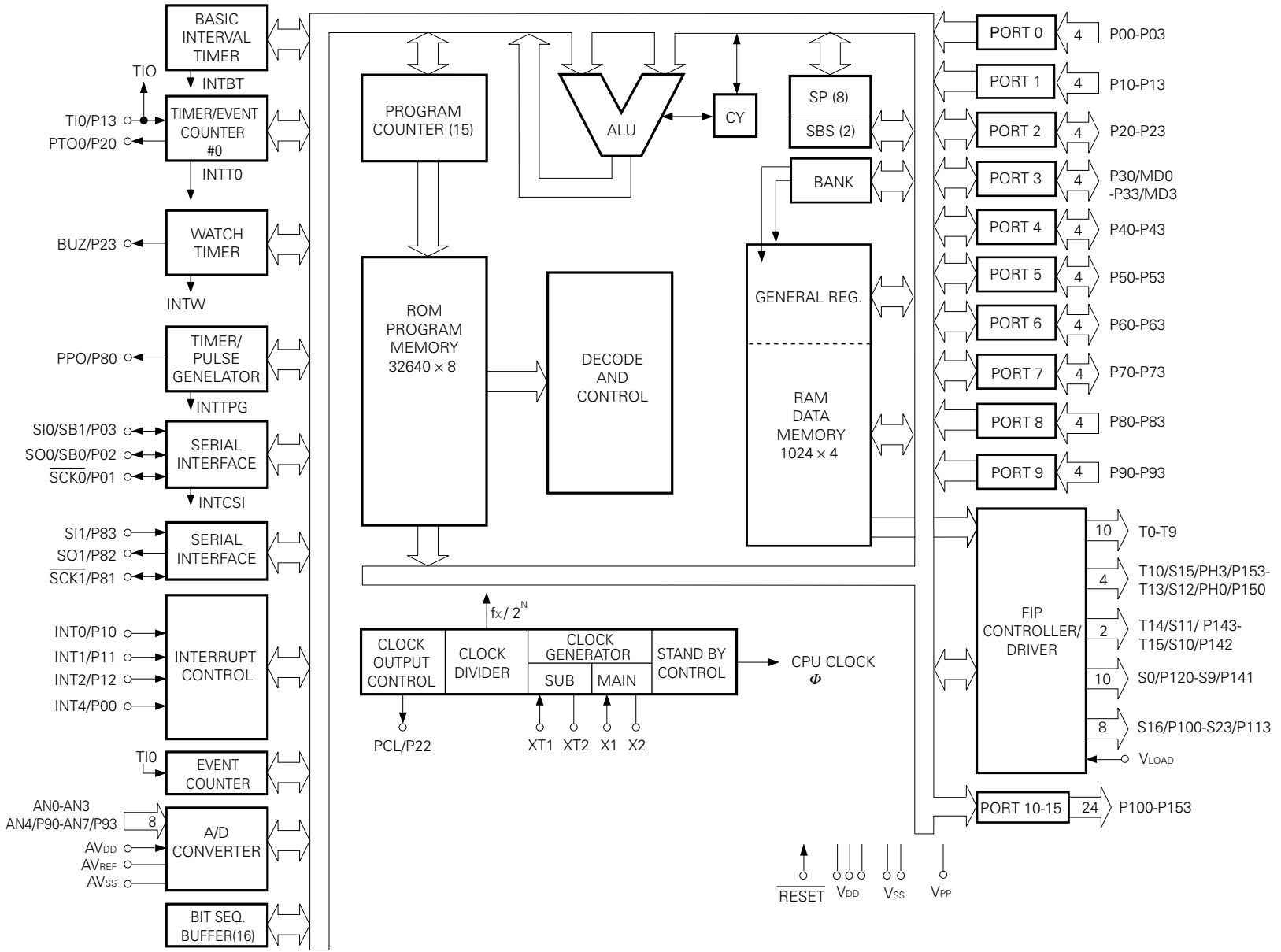

BLOCK DIAGRAM

1. PIN FUNCTIONS

1.1 PORT PINS (1/2)

Pin Name	Input/Output	Dual-Function Pin	Function	8-Bit I/O	After Reset	Input/Output Circuit Type*1
P00	Input	INT4	4-bit input port (PORT0). Internal pull-up resistor specification by software is possible for P01 to P03 as a 3-bit unit.	×	Input	ⓑ
P01		SCK0				ⓕ – A
P02		SO0/SB0				ⓕ – B
P03		SI0/SB1				Ⓜ – C
P10	Input	INT0	4-bit input port (PORT1). Internal pull-up resistor specification by software is possible as a 4-bit unit.	×	Input	ⓑ – C
P11		INT1				
P12		INT2				
P13		TI0				
P20	Input/output	PTO0	4-bit input/output port (PORT2). Internal pull-up resistor specification by software is possible as a 4-bit unit.	×	Input	E – B
P21		—				
P22		PCL				
P23		BUZ				
P30 to P33 *2	Input/output	MD0 to MD3	Programmable 4-bit input/output port (PORT3). Input/output settable bit-wise. Internal pull-up resistor specification by software is possible as a 4-bit unit.	×	Input	E – C
P40 to P43 *2	Input/output	—	N-ch open-drain 4-bit input/output port (PORT4). Data input/output pins for program memory write/verify (low-order 4 bits).	○	Input	M – A
P50 to P53 *2	Input/output	—	N-ch open-drain 4-bit input/output port (PORT5). Data input/output pins for program memory write/verify (high-order 4 bits).		Input	M – A
P60 to P63	Input/output	—	Programmable 4-bit input/output port (PORT6). Input/output settable bit-wise. Internal pull-up resistor specification by software is possible as a 4-bit unit.	○	Input	E – C
P70 to P73	Input/output	—	4-bit input/output port (PORT7).		Input	E

- * 1. A circle denotes Schmitt-triggered input.
2. Direct LED drive capability

1.1 PORT PINS (2/2)

Pin Name	Input/Output	Dual-Function Pin	Function	8-Bit I/O	After Reset	Input/Output Circuit Type*1
P80	Input/output	PPO	4-bit input port (PORT8).	×	Input	A
P81	Input/output	$\overline{SCK1}$				(E)
P82	Input/output	SO1				E
P83	Input	S11				(B)
P90 to P93	Input	AN4 to AN7	4-bit input port (PORT9).	×	Input	Y – A
P100 to P103	Output	S16 to S19	P-ch open-drain 4-bit high-voltage output port.	○	High impedance	I – D
P110 to P113	Output	S20 to S23	P-ch open-drain 4-bit high-voltage output port.			
P120 to P123	Output	S0 to S3	P-ch open-drain 4-bit high-voltage output port. Internal pull-down resistors.	○	V _{LOAD} level	I – E
P130 to P133	Output	S4 to S7	P-ch open-drain 4-bit high-voltage output port. Internal pull-down resistors.			I – E
P140	Output	S8	P-ch open-drain 4-bit high-voltage output port. Internal pull-down resistor on P140 only.	○	V _{LOAD} level	I – E
P141		S9				I – D
P142*2		S10/T15				
P143*2		S11/T14				
P150*2	Output	S12/T13/PH0	P-ch open-drain 4-bit high-voltage output port.	○	High impedance	I – D
P151*2		S13/T12/PH1				
P152*2		S14/T11/PH2				
P153*2		S15/T10/PH3				
PH0	Output	S12/T13/P150	P-ch open-drain 4-bit high-voltage output port.	×	High impedance	I – D
PH1		S13/T12/P151				
PH2		S14/T11/P152				
PH3		S15/T10/P153				

- * 1. A circle denotes Schmitt-triggered input.
 2. Direct LED drive capability.

1.2 NON-PORT PINS (1/2)

Pin Name	Input/Output	Dual-Function Pin	Function	After Reset	Input/Output Circuit Type*
PPO	Output	P80	Timer/pulse generator pulse output pin.	Input	A
TI0	Input	P13	External event pulse input pin for timer/event counter #0 or event counter #1.	—	(B) – C
PTO0	Output	P20	Timer/event counter output pin.	Input	E – B
PCL	Output	P22	Clock output pin.	Input	E – B
BUZ	Output	P23	Fixed-frequency output pin (for buzzer or system clock trimming use).	Input	E – B
$\overline{\text{SCK0}}$	Input/output	P01	Serial clock input/output pin.	Input	(F) – A
SO0/SB0	Input/output	P02	Serial data output pin. Serial bus input/output pin.	Input	(F) – B
SI0/SB1	Input/output	P03	Serial data input pin. Serial bus input/output pin.	Input	(M) – C
INT4	Input	P00	Edge-detected vectored interrupt input pin (either rising or falling edge detection).	—	(B)
INT0	Input	P10	Edge-detected vectored interrupt input pin (detected edge selectable).	Clocked	(B) – C
INT1		P11		Asynchronous	
INT2	Input	P12	Edge-detection testable input pin (rising edge detection).	Asynchronous	(B) – C
$\overline{\text{SCK1}}$	Input/output	P81	Serial clock input/output pin.	Input	(F)
SO1	Output	P82	Serial data output pin.	Input	E
SI1	Input	P83	Serial data input pin.	Input	(B)
AN0 to AN3	Input	—	A/D converter analog input pin.	—	Y
AN4 to AN7		P90 to P93			Y – A
AV _{REF}	Input	—	A/D converter reference voltage input pin.	—	Z
AV _{DD}	—	—	A/D converter power supply pin.	—	—
AV _{SS}	—	—	A/D converter reference GND potential pin.	—	—
X1, X2	Input	—	Main system clock oscillation crystal/ceramic resonator input. When an external clock is used, the clock is input to X1 and the inverted clock to X2.	—	—
XT1	Input	—	Subsystem clock oscillation crystal resonator input. When an external clock is used, the clock is input to XT1 and XT2 is left open.	—	—
XT2	—				
$\overline{\text{RESET}}$	Input	—	System reset input pin.	—	(B)
MD0 to MD3	Input	P30 to P33	Mode selection pin for program memory write/verify.	—	E – C
IC	—	—	Internally Connected . Connect to V _{SS} directly.	—	—
V _{PP}	—	—	Program voltage application pin for program memory write/verify . Connected to V _{DD} in normal operation. Applies +12.5 V in program memory write/verify.	—	—

★

* A circle denotes Schmitt-triggered input.

1.2 NON-PORT PINS (2/2)

Pin Name	Input/Output	Dual-Function Pin	Function	After Reset	Input/Output Circuit Type
V _{DD} (3 pins)	—	—	Positive power supply pins. Apply +6 V in PROM write/verify.	—	—
V _{SS} (2 pins)	—	—	Ground potential pin.	—	—
V _{LOAD}	—	—	FIP controller/driver pull-down resistor connection/ power supply pin.	—	I – D
T0 to T9 *	Output	—	Digit output high-voltage large large-current output pins.	V _{LOAD} level	I – E
T10/S15 to T13/S12		PH3/P153 to PH0/P150	Digit/segment output dual-function high-voltage large-current output pins. Unused pins usable as Port H. Usable as Port 15 in static mode.	High impedance	I – D
T14/S11		P143	Digit/segment output dual-function high-voltage large-current output pin. Usable as Port 14 in static mode.	High impedance	I – D
T15/S10		P142			
S0 to S3 *		P120 to P123	Segment high-voltage output pins. Usable as Port 12 to Port 14 in static mode.	V _{LOAD} level	I – E
S4 to S7 *		P130 to P133		V _{LOAD} level	I – E
S8 *		P140		V _{LOAD} level	I – E
S9		P141		High impedance	I – D
S16 to S19		P100 to P103		Segment high-voltage output pins. Usable as Port 10 & Port 11 in static mode.	High impedance
S20 to S23		P110 to P113	High impedance		I – D

* Internal pull-down resistor

1.3 PIN INPUT/OUTPUT CIRCUITS

The input/output circuits for each of the pins are shown in Fig. 1-1 in partially simplified form.

Fig. 1-1 Pin Input/Output Circuits (1/3)

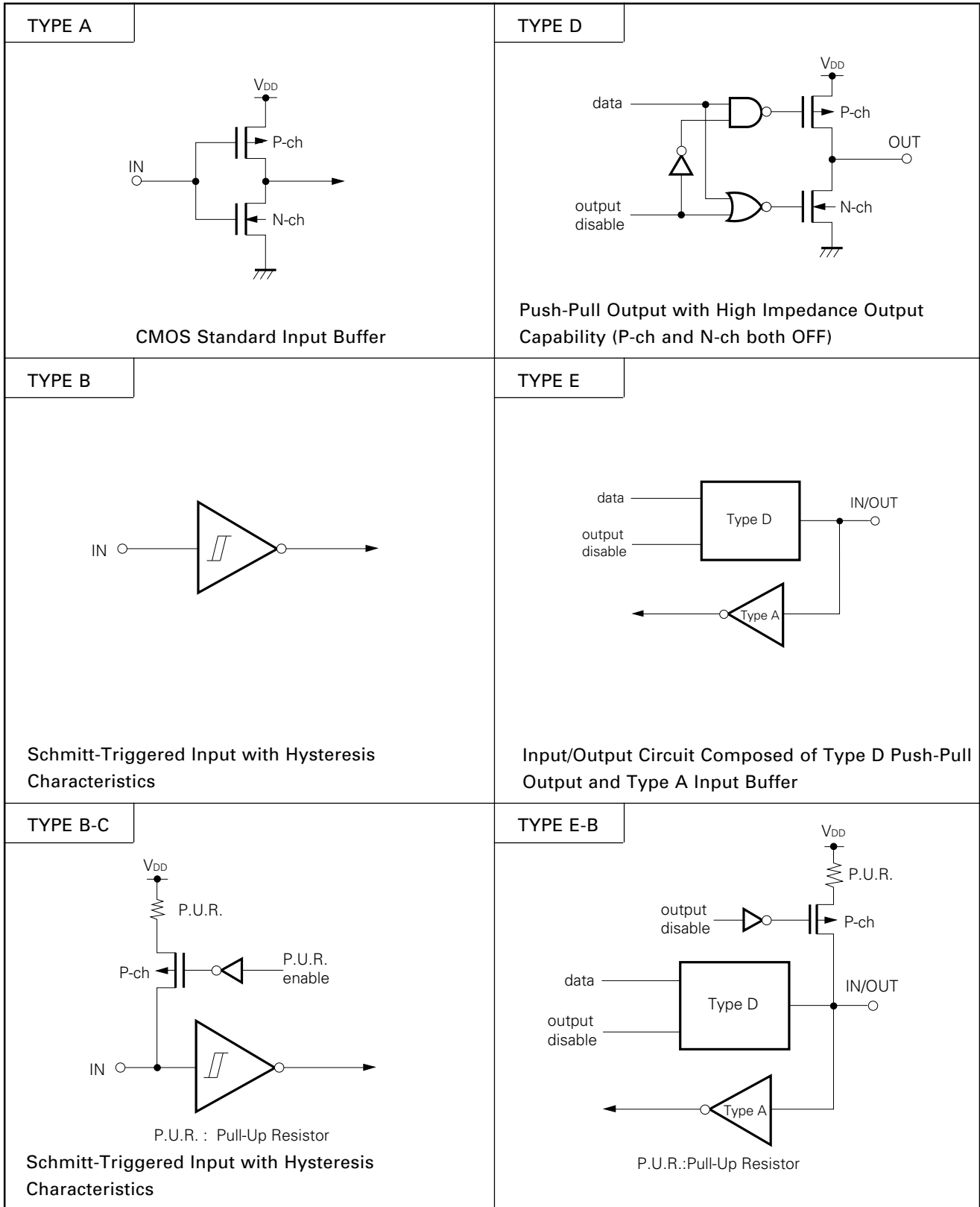

Fig. 1-1 Pin Input/Output Circuits (2/3)

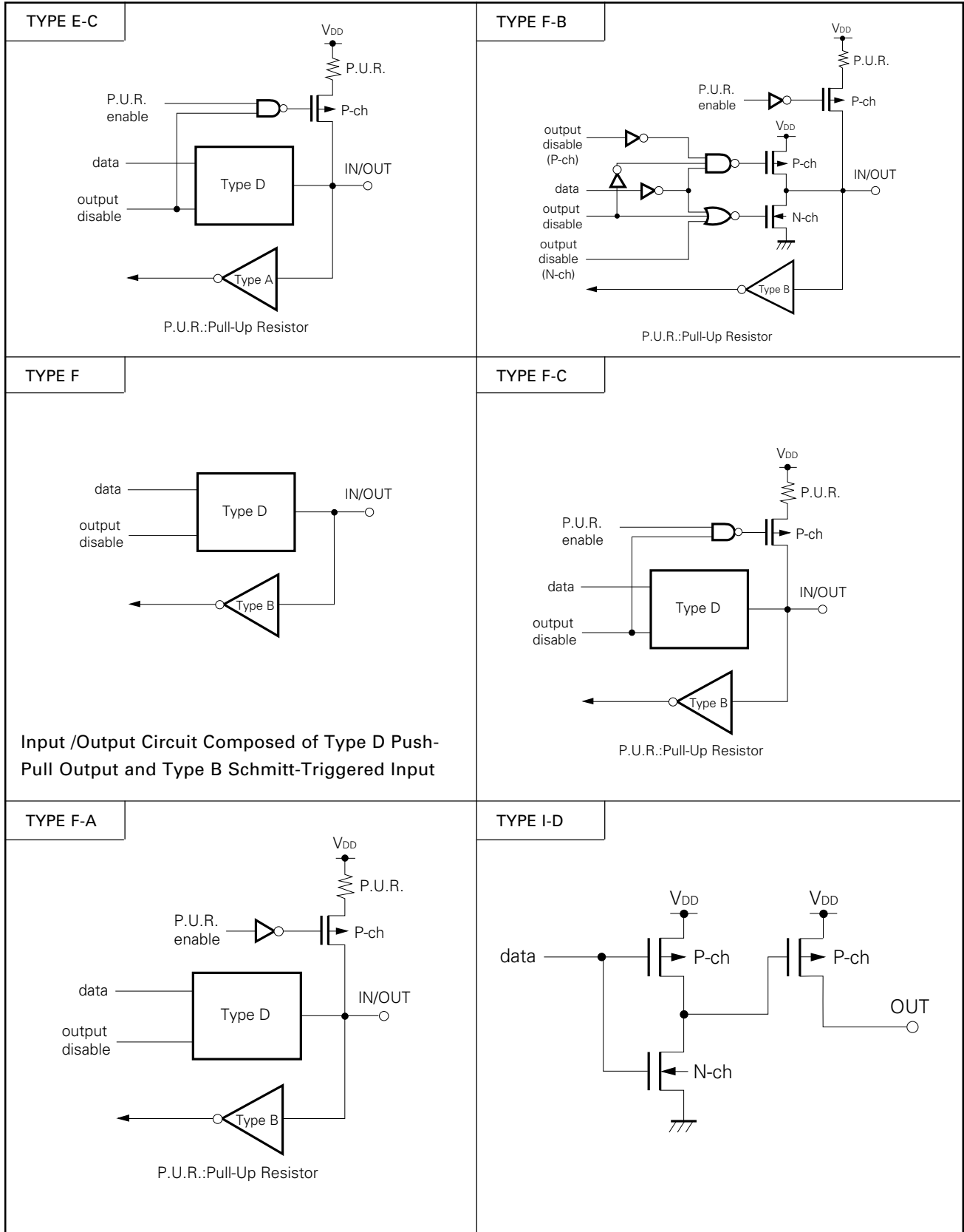
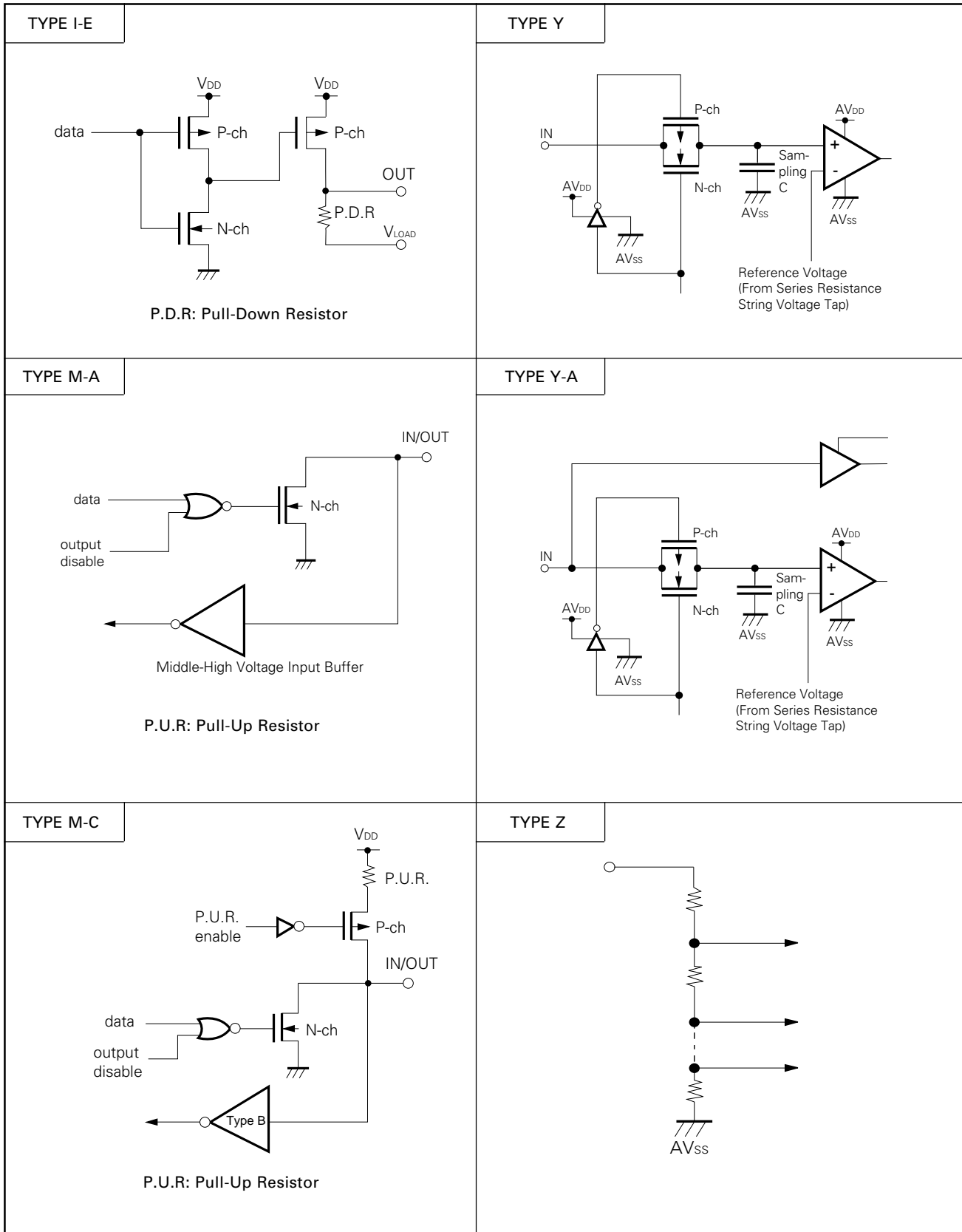

Fig. 1-1 Pin Input/Output Circuits (3/3)



1.4 DISPOSITION OF UNUSED PIN

Table 1-2 Recommended Connection of Unused Pins (1/2)

Pin	Recommended Connection	
P00/INT4	Connect to V _{SS} .	
P01/ $\overline{\text{SCK0}}$	Connect to V _{SS} or V _{DD} .	
P02/SO0/SB0		
P03/SI1/SB1		
P10/INT0 to P12/INT2	Connect to V _{SS} .	
P13/TI0		
P20/PTO0	Input state : Connect to V _{SS} or V _{DD} . Output state : Leave open.	
P21		
P22/PCL		
P23/BUZ		
P30 to P33		
P40 to P43		
P50 to P53		
P60 to P63		
P70 to P73		
P80 to PPO		Connect to V _{SS} or V _{DD} .
P81 to $\overline{\text{SCK1}}$		
P82/SO1		
P83/SI1		
P90/AN4 to P93/AN7	Connect to V _{SS} .	

Table 1-2 Recommended Connection of Unused Pins (2/2)

Pin	Recommended Connection
P100/S16 to P103/S19	Leave open.
P110/S20 to P113/S23	
P120 to P123	
P130 to P133	
P140 to P143	
P150 to P153	
AN0 to AN3	Connect to V _{SS} .
AV _{REF}	
AV _{DD}	Connect to V _{DD} .
AV _{SS}	Connect to V _{SS} .
XT1	Connect to V _{SS} or V _{DD} .
XT2	Leave open.
V _{LOAD}	Connect to V _{SS} or leave open.
IC	Connect to V _{SS} .

★

2. DIFFERENCES BETWEEN μPD75P238 AND μPD75238

The μPD75P238 is a product with the program memory of the μPD75238 using on-chip mask ROM replaced by one-time PROM or EPROM. Table 2-1 shows differences between μPD75P238 and μPD75238. The differences between these products must be thoroughly checked when, for example, switching from use of PROM for application system debugging and reproduction to use of a mask ROM product for volume production.

For details of CPU function and on-chip hardware, refer to the document "μPD75238 User's Manual" (IEU-731).

Table 2-1 Differences between μPD75P238 and μPD75238

Parameter		Product Name	μPD75238	μPD75P238
ROM			Mask ROM 32K × 8	One-time PROM, EPROM 32K × 8
RAM			1K × 4	
FIP controller/ driver	No. of segments		9 to 24	
	No. of digits		9 to 16	
Pull-up resistors	Ports 4 & 5		No	
Pull-down resistors	Port 7		No	
	S0 to S8	Mask option	On-chip	
	S9		No	
	S16 to S23		No	
	T0 to T9		On-chip	
	T10 to T15		No	
Pin connection	Pin 5			V _{DD}
	Pins 70 to 73		P30 to P33	P30/MD0 to P33/MD3
★	Electrical specifications	The mask ROM products and PROM products have different consumption currents, operating temperature range etc. See the Electrical Specifications section in the relevant Data Sheet for details.		
	Operating supply voltage range	2.7 to 6.0 V		
	Subsystem clock feedback resistor		Mask option	On-chip
	Package		94-pin plastic QFP (□20 mm)	94-pin plastic QFP (□20 mm) 94-pin ceramic WQFN
★	Others	The mask ROM products and PROM products have different circuit scales and mask layouts, and therefore differ in terms of noise resistance and noise radiation.		

★ **Note** Noise resistance and noise radiation differs between the PROM products and mask ROM products. When investigating a switch from preproduction to volume production, throughout evaluation should be carried out with the mask ROM CS product (not the ES product).

3. PROGRAM MEMORY (PROM)

The program memory is PROM with a 32640×8 -bit configuration which stores program and table data etc.

The program memory is addressed by the program counter. In addition, table data can be referenced by a table referencing instruction (MOVT).

The range of address to which branch instructions and subroutine call instructions and subroutine call instructions and subroutine call instructions can branch is shown in Fig. 3-1. The entire space comprising 0000H to 7F7FH can be directly branched to by the entire-space branch instruction (BRA !addr1) and the entire-space call instruction (CALLA !addr1). The relative branch instruction (BR \$addr) allows branching to addresses [PC contents -15 to -1 and +2 to +16] irrespective of block boundaries.

In addition, the following addresses are specially allocated (except for 0000H and 0001H, the entire area can be used as ordinary program memory).

- Addresses 0000H & 0001H

Vector table to which the program start address and MBE & RBE set value upon RESET input are written.

Reset servicing can be started from any address in the 16K (000H to 3FFFH).

- Addresses 0002H to 000FH

Vector table to which the program start address and MBE & RBE set value for the various vectored interrupts are written. Interrupt servicing can be started from any address in the 16K space (0000H to 3FFFH).

- Addresses 0020H to 007FH

Table area referenced by GETI instruction*.

- * The GETI instruction allows any 2- or 3-byte instruction or any two 1-byte instructions to be implemented as 1 byte, and is used to reduce the number of program steps.

Fig. 3-1 Program Memory Map

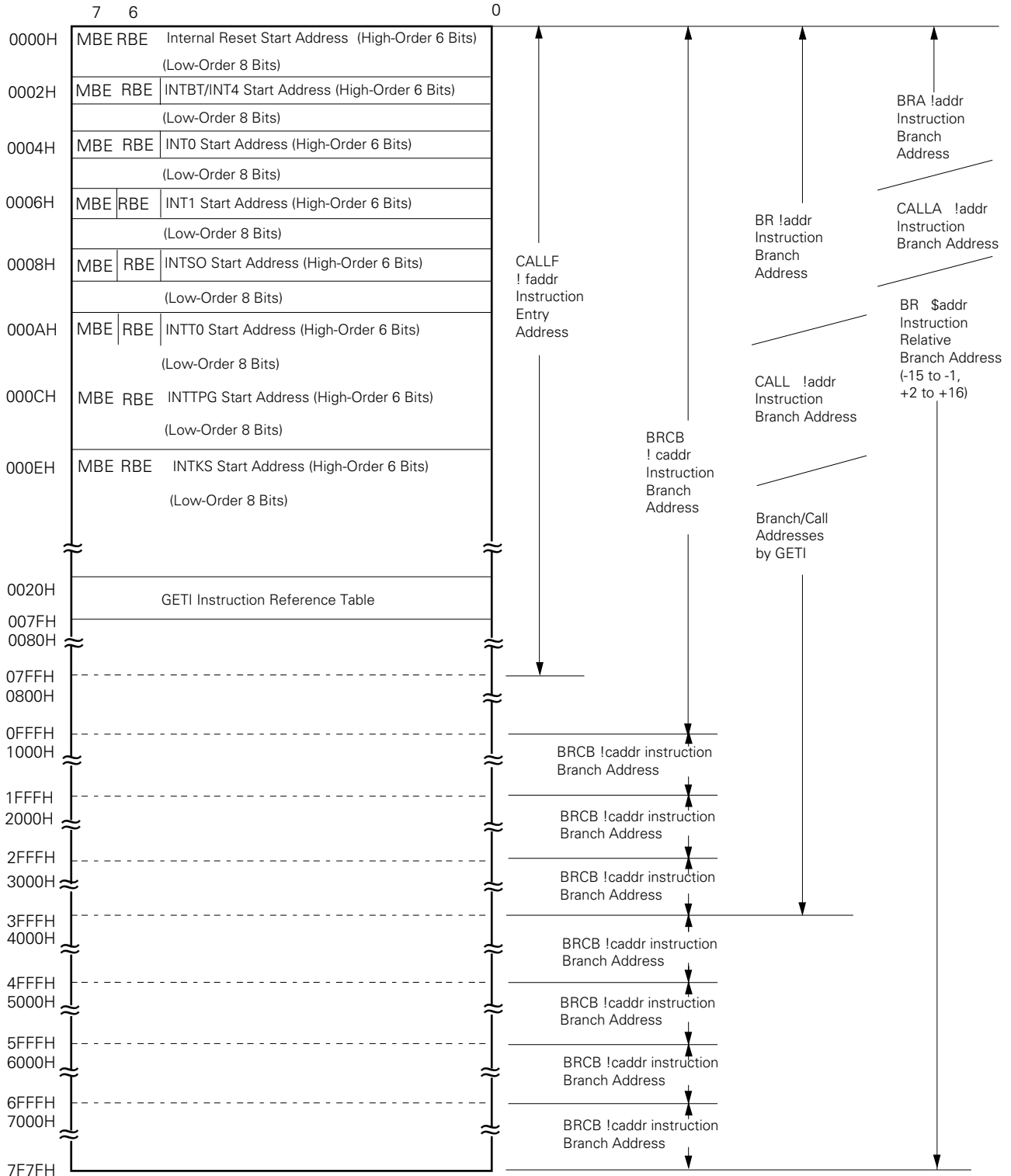

Note The above interrupt vector start addresses are 14-bit, and thus should be set in the 16K space (0000H to 3FFFH).

Remarks In addition to the above, branching is possible with the BR PCDE and BR PCXA instructions to addresses with the low-order 8 bits only of the PC modified.

4. STACK BANK SELECTION REGISTER (SBS)

The stack bank selection register specifies one memory bank from memory banks 0 to 3 as the stack area. Its format is shown in Fig. 4-1.

The stack bank selection register is set by a 4-bit memory manipulation instruction. On $\overline{\text{RESET}}$ input bit only is set to "1" and the remaining bits are undefined. Therefore this register must always be initialized to 00xxB* at the start of a program.

Fig. 4-1 Stack Bank Selection Register Format

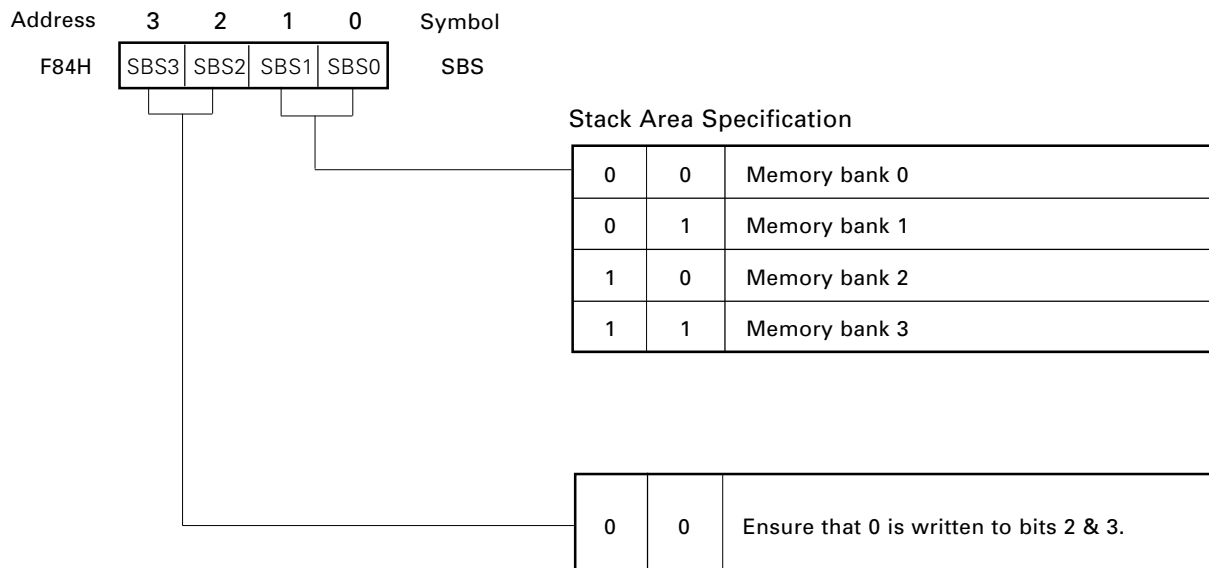

Note After $\overline{\text{RESET}}$ input a subroutine call instruction and interrupt enabling instruction should be executed after setting the stack bank selection register.

* xx should be set to the desired value.

5. PROGRAM MEMORY WRITE AND VERIFY OPERATIONS

The program memory incorporated in the μPD75P238 is 32640 × 8-bit electrically writable PROM. Write/verify operations on this PROM are executed using the pins shown in the table below. Address updating is performed by means of clock input from the X1 pin rather than by address input.

Table 5-1 Pins Used for Program Memory Write/Verify

Pin Name	Function
V _{PP}	Voltage application pin for program memory write/verify (normally V _{DD} potential).
X1, X2	Address update clock input for program memory write/verify. Inverse of X1 pin signal is input to X2 pin.
MD0 to MD3	Operating mode selection pin for program memory write/verify.
P40 to P43 (low-order 4 bits) P50 to P53 (high-order 4 bits)	8-bit data input/output pin for program memory write/verify.
V _{DD}	Supply voltage application pin. Applies 2.7 to 6.0 V in normal operation, and 6 V for program memory write/verify.

Note 1. Pins not used in a program memory write/verify operation are handled as follows:

- Ports 0 to 2, ports 6 to 15 } Connect to GND
- T0 to T9, AN0 to AN3, XT1 } Connect to GND
- V_{LOAD}, AV_{REF}, AV_{SS}, RESET } Connect to GND
- AV_{DD} Connect to V_{DD}
- XT2 Leave open

2. On the μPD75P238KF which is equipped with an erase window the shading cover film should be attached except when performing EPROM erasure.
3. Since the μPD75P238GJ one-time PROM version is not provided with an erase window, program memory contents cannot be erased.

5.1 PROGRAM MEMORY WRITE/VERIFY OPERATING MODES

When +6 V is applied to the V_{DD} pin and +12.5 V to the V_{PP} pin, the μPD75P238 enters the program memory write/verify mode. This mode comprises one of the operating modes shown in Table 5-2 according to the setting of pins MD0 to MD3.

Table 5-2 Program Memory Write/Verify Operating Modes

Operating Mode Setting						Operating Mode
V _{PP}	V _{DD}	MD0	MD1	MD2	MD3	
+ 12.5 V	+ 6 V	H	L	H	L	Program memory address zero-clear
		L	H	H	H	Write mode
		L	L	H	H	Verify mode
		H	×	H	H	Program inhibit mode

Remarks × : L or H

5.2 PROGRAM MEMORY WRITE PROCEDURE

The procedure for writing to program memory is as shown below, allowing high-speed writing.

- (1) Unused pins are connected to V_{SS}. The X1 pin is driven low.
- (2) 5 V is supplied to the V_{DD} and V_{PP} pins.
- (3) 10 μs wait.
- (4) Program memory address zero-clear mode.
- (5) 6V is supplied to V_{DD}, 12.5 V to V_{PP}.
- (6) Program inhibit mode.
- (7) Data is written in 1 ms write mode.
- (8) Program inhibit mode.
- (9) Verify mode. If write is successful go to (10), otherwise repeat (7) to (9).
- (10) (Number of times written in (7) to (9): X) × 1 ms additional writes.
- (11) Program inhibit mode.
- (12) Program memory address is updated (+1) by inputting 4 pulses to the X1 pin.
- (13) Steps (7) to (12) are repeated until the last address.
- (14) Program memory address zero-clear mode.
- (15) V_{DD} / V_{PP} pin voltage is changed to 5 V.
- (16) Power-off.

Steps (2) to (12) of this procedure are shown in Fig. 5-1.

Fig. 5-1 Program Memory Write Timing

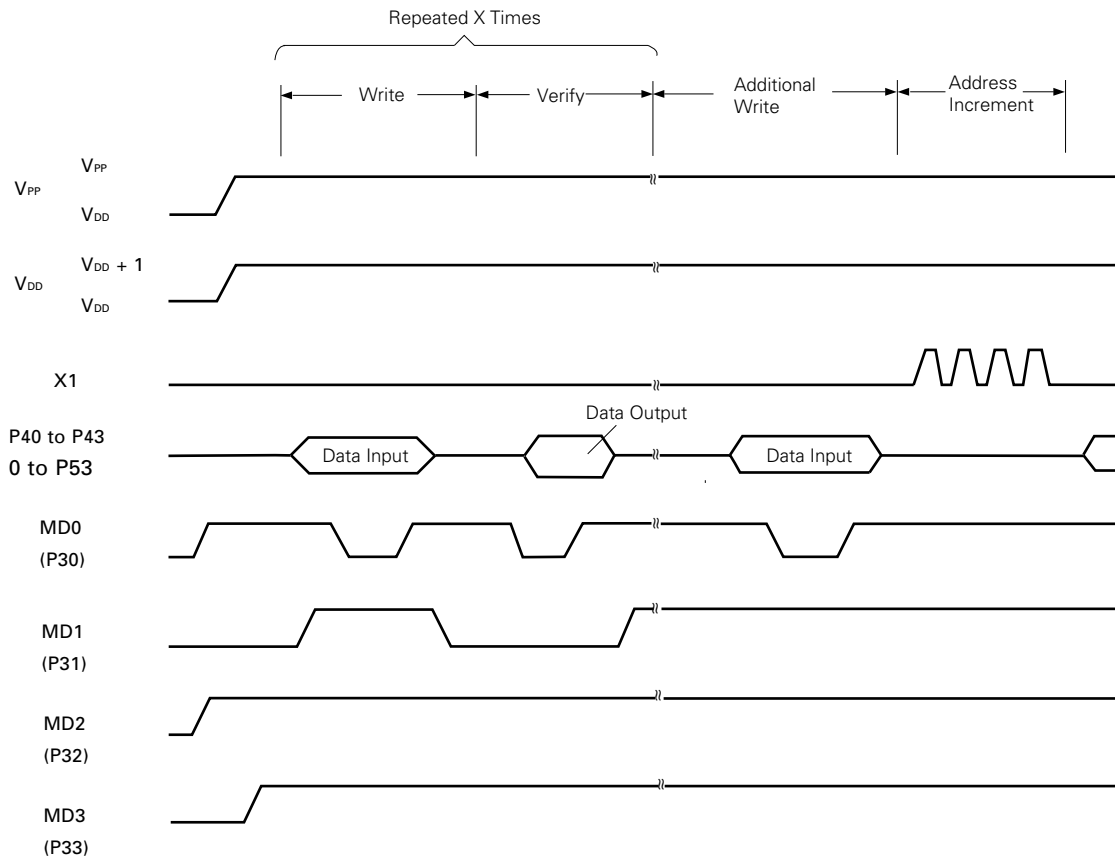

5.3 PROGRAM MEMORY READ PROCEDURE

μPD75P238 program memory contents can be read using the following procedure. Reading is performed in verify mode.

- (1) Unused pins are connected to V_{SS}. The X1 pin is driven low.
- (2) 5 V is supplied to the V_{DD} and V_{PP} pins.
- (3) 10 μs wait.
- (4) Program memory address zero-clear mode.
- (5) 6 V supplied to V_{DD}, and 12.5 V to V_{PP}.
- (6) Program inhibit mode.
- (7) Verify mode. When clock pulses are input to the X1 pin, data is output sequentially, one address per 4-pulse-input cycle.
- (8) Program inhibit mode.
- (9) Program memory address zero-clear mode.
- (10) V_{DD} / V_{PP} pin voltage is changed to 5 V.
- (11) Power-off.

Steps (2) to (9) of this procedure are shown in Fig. 5-2.

Fig. 5-2 Program Memory Read Timing

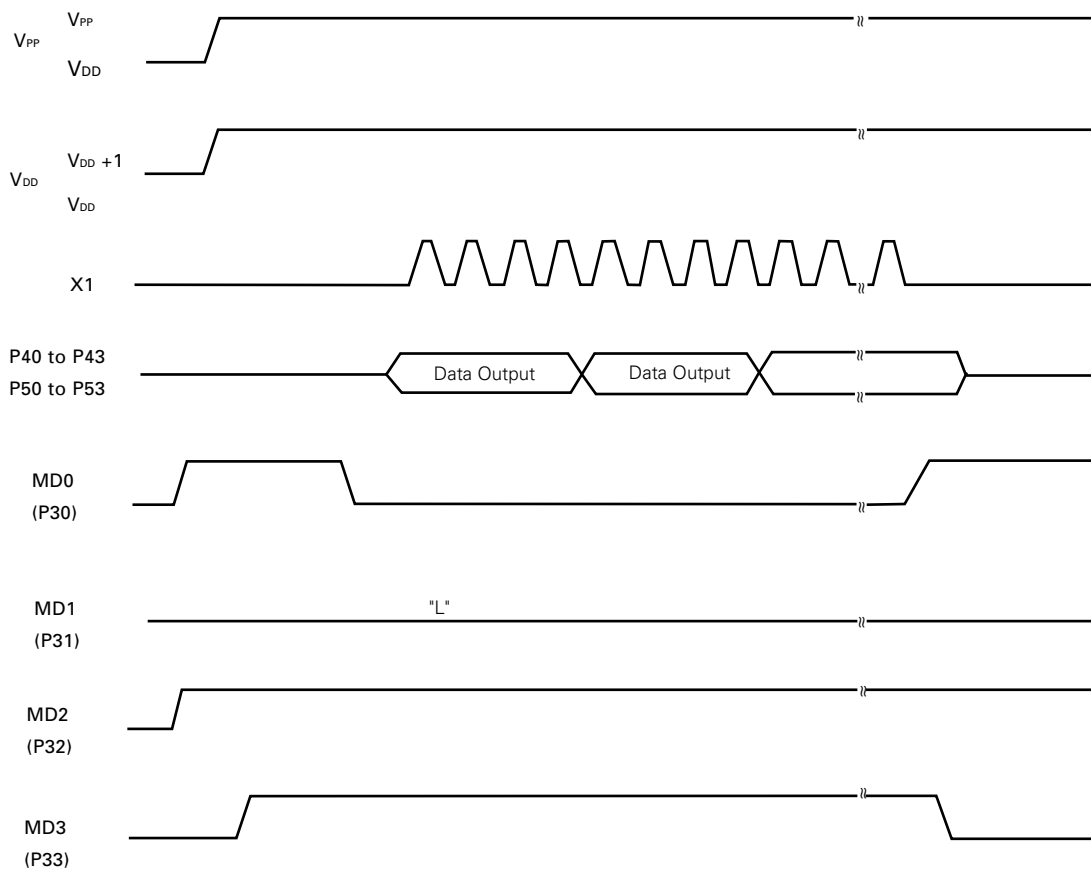

5.4 ERASURE (μ PD75P238KF ONLY)

The Programmed data contents of the μ PD75P238KF can be erased by exposure to ultraviolet light through the window in the top.

The ultraviolet wave length which effects erasure is 250 nm, and the quantity of radiation necessary for complete erasure is $15 \text{ W}\cdot\text{s}/\text{cm}^2$ (ultraviolet radiation intensity x erasure time). Using a commercially available ultraviolet lamp (254 nm vavelength, $12 \text{ mW}/\text{cm}^2$ intensity) erasure can be accomplished in approximately 15 to 20 minutes.

- Note**
- 1. Memory contents may also be erased by prolonged exposure to direct sunlight fluorescent lighting. To protect the contents ensure that the top window is masked with the shading cover film. The shading cover film supplied with NEC's UV EPROM products should be used.**
 - 2. When carrying out erasure the distance between the ultraviolet lamp and the μ PD75P238KF should normally be no greater than 2.5 cm.**

Remarks A longer erasure time may be required if there is deterioration of the ultraviolet lamp, or if the package window is not clean, etc.

6. ELECTRICAL SPECIFICATIONS

ABSOLUTE MAXIMUM RATINGS (Ta = 25°C)

PARAMETER	SYMBOL	TEST CONDITIONS		RATING	UNIT
Supply voltage	V _{DD}			-0.3 to +7.0	V
	V _{LOAD}			V _{DD} -40 to V _{DD} +0.3	V
	V _{PP}			-0.3 to +13.5	V
Input voltage	V _{I1}	Except ports 4, 5		-0.3 to V _{DD} +0.3	V
	V _{I2}	Ports 4, 5	Open-drain	-0.3 to +11	V
Output voltage	V _O	Pins except display output pins		-0.3 to V _{DD} +0.3	V
	V _{OD}	Display output pins		V _{DD} -40 to V _{DD} +0.3	V
Output current high	I _{OH}	1 pin except display output pins		-15	mA
		S0 to S9, S16 to S23 1 pin		-15	mA
		T0 to T15 1 pin		-30	mA
		All pins except display output pins		-30	mA
		All display output pins		-120	mA
Output current low	I _{OL} *	1 pin	Peak value	30	mA
			Effective value	15	mA
		Total of port 0, 2, 3, 4	Peak value	100	mA
			Effective value	60	mA
		Total of port 5 to 8	Peak value	100	mA
			Effective value	60	mA
Operating temperature	T _{opt}			-40 to +70	°C
Storage temperature	T _{stg}			-65 to +150	°C

* The Effective value should be calculated as follows. [Effective value] = [Peak value] × √Duty

Note Product quality may suffer if the absolute maximum rating is exceeded for even a single parameter, or even momentarily. In other words, the absolute maximum ratings are rated values at which the product is on the verge of suffering physical damage, and therefore the product must be used under conditions which ensure that the absolute ratings are not exceeded. ★

OPERATING SUPPLY VOLTAGE RANGE (Ta = -40 to +70 °C)

PARAMETER	TEST CONDITIONS	MIN.	MAX.	UNIT
CPU*1		*2	6.0	V
Display controller		4.5	6.0	V
Timer/pulse generator		4.5	6.0	V
Other hardware*1		2.7	6.0	V

- * 1. Except the system clock oscillator, display controller and timer/pulse generator.
- 2. The operating power supply voltage range varies depending on the cycle time. Refer to the section describing AC characteristics.

MAIN SYSTEM CLOCK RESONATOR CHARACTERISTICS (Ta = -40 to +70 °C, VDD = 2.7 to 6.0 V)

RESONATOR	RECOMMENDED CHARACTERISTICS	PARAMETER	TEST CONDITIONS	MIN.	TYP.	MAX.	UNIT
Ceramic resonator		Oscillator frequency (fx)*1	VDD = Oscillator voltage range	2.0		6.2	MHz
		Oscillation stabilization time*2	After VDD has reached MIN. value of oscillator voltage range.			4	ms
Crystal resonator		Oscillator frequency (fx)*1		2.0	4.19	6.2	MHz
		Oscillation stabilization time*2	VDD = 4.5 to 6.0 V			10	ms
External Clock		X1 input frequency (fx)*1		2.0		6.2	MHz
		X1 input high and low level width (txH, txL)		81		250	ns

- * 1. Oscillator frequency and input frequency indicate oscillator characteristics only. Refer to the AC characteristics for the instruction execution time.
- 2. Oscillation stability time is time required for oscillation to stabilize after VDD has reached the MIN. value in oscillation voltage range or STOP mode has been released.

Note When the main system clock oscillator is used, the following should be noted concerning wiring in the area in the figure enclosed by a dotted line to prevent the influence of wiring capacitance, etc. ★

- The wiring should be kept as short as possible.
- No other signal lines should be crossed.
- Keep away from lines carrying a high fluctuating current.
- The oscillator capacitor grounding point should always be at the same potential as Vss. Do not connect to a ground pattern carrying a high current.
- A signal should not be taken from the oscillator.

SUBSYSTEM CLOCK OSCILLATOR CHARACTERISTICS (Ta = -40 to +70 °C, VDD = 2.7 to 6.0 V)

RESONATOR	RECOMMENDED CHARACTERISTICS	PARAMETER	TEST CONDITIONS	MIN.	TYP.	MAX.	UNIT
Crystal resonator		Oscillator frequency (f _{XT})*1		32	32.768	35	kHz
		Oscillation stabilization time*1	V _{DD} = 4.5 to 6.0 V		1.0	2	s
External Clock		XT1 input frequency (f _{XT})*1		32		100	kHz
		X1 input high and low level width (t _{XTH} , t _{XTL})		5		15	μs

- * 1. Oscillator frequency and input frequency indicate oscillator characteristics only. Refer to the AC characteristics for the instruction execution time.
- 2. Oscillation stability time is time required for oscillation to stabilize after V_{DD} has reached the MIN. value in oscillation voltage range.

★ **Note** When subsystem clock oscillator is used, the following should be noted concerning wiring in the area in the figure enclosed by a dotted line to prevent the influence of wiring capacitance, etc.

- The wiring should be kept as short as possible.
- No other signal lines should be crossed.
- Keep away from lines carrying a high fluctuating current.
- The oscillator capacitor grounding point should always be at the same potential as V_{SS}. Do not connect to a ground pattern carrying a high current.
- A signal should not be taken from the oscillator.

The subsystem clock oscillator is a low-amplitude circuit in order to achieve a low consumption current, and is more prone to misoperation due to noise than the main system, clock oscillator. Particular care is therefore required with the wiring method when the subsystem clock is used.

CAPACITANCE (Ta =25 °C, VDD = 0 V)

PARAMETER	SYMBOL	TEST CONDITIONS	MIN.	TYP.	MAX.	UNIT
Input capacitance	C _i	f = 1 MHz 0 V for pins except measured pins			15	pF
Output capacitance (Output except display output)	C _o				15	pF
Input/output capacitance	C _{io}				15	pF
Output capacitance (Display output)	C _o				35	pF

RECOMMENDED OSCILLATOR CONTANTS

MAINSYSTEMCLOCK : CERAMIC RESONATOR (Ta = - 40 to + 85 °C)

MAUNFAC- TURER	PRODUCT NAME	FREQUENCY (MHz)	RECOMMENDED OSCILLATOR CONSTANTS(pF)		OSCILLATOR VOLTAGE RANGE(V)		REMARKS		
			C1	C2	MIN.	MAX.			
Murata Mfg.	CSA2.0MG ----- CST2.0MG	2.0	30	30	2.7	6.0	----- On-chip capacitor product		
	CSA2.5MG093 ----- CST2.5MGW093		30	30				----- On-chip capacitor product	
	CSA4.19MGU ----- CST4.19MGWU	4.19	30	30			----- On-chip capacitor product		
	CSA2.5MG ----- CST2.5MGW		2.5	30				30	3.0
	CSA4.19MG ----- CST4.19MGW	4.19		30			30	3.3	
	CSA6.0MG ----- CST6.0MGW		6.00	30			30		4.0
				-			-		

MAIN SYSTEM CLOCK : CRYSTAL RESONATOR (Ta = - 20 to + 70 °C)

MAUNFAC- TURER	PRODUCT NAME	FREQUENCY (MHz)	RECOMMENDED OSCILLATOR CONSTANTS(pF)		OSCILLATOR VOLTAGE RANGE(V)		REMARKS
			C1	C2	MIN.	MAX.	
Kinseki, Ltd.	HC-49/U-S	3.072 to 6.000	22	22	4.0	6.0	

DC CHARACTERISTICS (Ta = -40 to +70 °C, VDD = 2.7 to 6.0 V) (1/3)

PARAMETER	SYMBOL	TEST CONDITIONS		MIN.	TYP.	MAX.	UNIT	
Input voltage high	V _{IH1}	All ports and pins except those listed below.		0.7 V _{DD}		V _{DD}	V	
	V _{IH2}	Port 0, 1, $\overline{\text{RESET}}$, P81, P83		0.8 V _{DD}		V _{DD}	V	
	V _{IH3}	X1, X2, XT1		V _{DD} - 0.4		V _{DD}	V	
	V _{IH4}	Port 7	V _{DD} = 4.5 to 6.0 V	0.65 V _{DD}		V _{DD}	V	
				0.7 V _{DD}		V _{DD}	V	
V _{IH5}	Port 4, 5	Open-drain	0.7 V _{DD}		10	V		
Input voltage low	V _{IL1}	All ports and pins except those listed below.		0		0.3 V _{DD}	V	
	V _{IL2}	Port 0, 1, $\overline{\text{RESET}}$, P81, P83		0		0.2 V _{DD}	V	
	V _{IL3}	X1, X2, XT1		0		0.4	V	
Output voltage high	V _{OH}	All output pins, except port 4, 5 and P03	V _{DD} = 4.5 to 6.0 V	I _{OH} = -1 mA	V _{DD} - 1.0		V	
			V _{DD} = 2.7 to 6.0 V	I _{OH} = -100 μA	V _{DD} - 0.5		V	
Output voltage low	V _{OL}	Ports 3, 4, 5	V _{DD} = 4.5 to 6.0 V	I _{OH} = 15 mA		0.4	2.0	V
		All output pins	V _{DD} = 4.5 to 6.0 V	I _{OL} = 1.6 mA			0.4	V
			V _{DD} = 2.7 to 6.0 V	I _{OL} = 400 μA			0.5	V
		SB0, SB1	Open-drain pull-up resistor ≥ 1 kΩ				0.2 V _{DD}	V
Input leakage current high	I _{LIH1}	All ports and pins except those listed below.	V _{IN} = V _{DD}			3	μA	
	I _{LIH2}				X1, X2, XT1		20	μA
	I _{LIH3}	Ports 4, 5	V _{IN} = 10 V			20	μA	
Input leakage current low	I _{LIL1}	All ports and pins except those listed below.	V _{IN} = 0 V			-3	μA	
	I _{LIL2}				X1, X2, XT1		-20	μA

DC CHARACTERISTICS (Ta = -40 to +70 °C, VDD = 2.7 to 6.0 V) (2/3)

PARAMETER	SYMBOL	TEST CONDITIONS		MIN.	TYP.	MAX.	UNIT	
Output leakage current high	I _{LOH1}	All ports and pins except those listed below.	V _{OUT} = V _{DD}			3	μA	
	I _{LOH2}	Port 4, 5	V _{OUT} = 10 V			20	μA	
Output leakage current low	I _{LOL1}	All ports and pins except those listed below.	V _{OUT} = 0 V			-3	μA	
	I _{LOL2}	Display output	V _{OUT} = V _{LOAD} = V _{DD} - 35 V			-10	μA	
Display output current	I _{OD}	S0 to S9, S16 to S23	V _{DD} = 4.5 to 6.0 V V _{OD} = V _{DD} - 2 V	-3	-5.5		mA	
		T0 to T15		-15	-22		mA	
On-chip pull-down resistor (Mask option)	R _L	Display output	V _{OD} - V _{LOAD} = 35 V	25	50	135	kΩ	
On-chip pull-up resistor	R _{V1}	Port 0, 1, 2, 3, 6 (Except P00) V _{IN} = 0 V	V _{DD} = 5 V ± 10%	15	40	80	kΩ	
			V _{DD} = 3 V ± 10%	30		300	kΩ	
Power supply current*1	I _{DD1}	6MHz crystal oscillation C1 = C2 = 22 pF*4	Operating mode	V _{DD} = 5 V ± 10%*2		9	18	mA
				V _{DD} = 3 V ± 10%*3		1	3	mA
	HALT mode		V _{DD} = 5 V ± 10%		900	2700	μA	
			V _{DD} = 3 V ± 10%		300	900	μA	
	I _{DD2}	4.19MHz crystal oscillation C1 = C2 = 22 pF*4	Operating mode	V _{DD} = 5 V ± 10%*2		5	15	mA
				V _{DD} = 3 V ± 10%*3		0.9	2.7	mA
	HALT mode		V _{DD} = 5 V ± 10%		600	1800	μA	
			V _{DD} = 3 V ± 10%		200	600	μA	

- * 1. Current to the on-chip pull-down resistor (pull-up) and power-on reset circuit (mask option) is not included.
- 2. When the processor clock control register (PCC) is set to 0011 and is operated at high-speed mode.
- 3. When the PCC register is set to 0000 and is operated in the low-speed mode.
- 4. Includes the case where the subsystem clock oscillating.

DC CHARACTERISTICS (Ta = -40 to +70 °C, VDD = 2.7 to 6.0 V) (3/3)

PARAMETER	SYMBOL	TEST CONDITIONS		MIN.	TYP.	MAX.	UNIT	
Power supply current*1	I _{DD3}	32 kHz crystal oscillation*2	Operating mode	V _{DD} = 3 V ±10%		100	300	μA
	I _{DD4}		HALT mode	V _{DD} = 3 V ±10%		20	60	μA
	I _{DD5}	XT1 = 0 V STOP mode	V _{DD} = 5 V ±10%			0.5	20	μA
			V _{DD} = 3 V ±10%			0.3	10	μA
				Ta = 25°C			5	μA
I _{DD6}	32 kHz crystal oscillation*2	STOP mode	V _{DD} = 3 V ±10%		5	15	μA	

- * 1. Current to the on-chip pull-down resistor (pull-up) and power-on reset circuit (mask option) is not included.
- 2. When the system clock control register (SCC) is set to 1001 and is operated with the subsystem clock with main system clock oscillation stopped.

A/D CONVERTER CHARACTERISTICS (Ta = -40 to +70 °C, VDD = 2.7 to 6.0 V, AVSS = VSS = 0 V, 2.7 ≤ AVDD ≤ VDD)

PARAMETER	SYMBOL	TEST CONDITIONS		MIN.	TYP.	MAX.	UNIT
Resolution				8	8	8	bit
Absolute accuracy*1		2.5 V ≤ AV _{REF} ≤ V _{DD}	-10 ≤ Ta ≤ +70°C			±1.5	LSB
			-40 ≤ Ta < -10°C			±2.0	
Conversion time	t _{CONV}	*2				168/f _x	μs
Sampling time	t _{SAMP}	*3				44/f _x	μs
Analog input voltage	V _{IAN}			AV _{SS}		AV _{REF}	V
Analog input impedance	R _{AN}				1000		MΩ
AV _{REF} current	I _{A_{REF}}				1.0	2.0	mA

- * 1. Absolute accuracy except quantization error (±1/2 LSB).
- 2. Time from execution of conversion start instruction to EOC = 1 (28.0 μs when f_x = 6.0 MHz, 40.1 μs when f_x = 4.19 MHz)
- 3. Time from execution of conversion start instruction to the end of sampling (7.33 μs when f_x = 6.0 MHz, 10.5 μs when f_x = 4.19 MHz)

AC CHARACTERISTICS (Ta = -40 to +70 °C, VDD = 2.7 to 6.0 V)

(1) Basic Operation

PARAMETER	SYMBOL	TEST CONDITIONS	MIN.	TYP.	MAX.	UNIT	
CPU clock cycle time (minimum instruction execution time = one machine cycle)*1	t _{cy}	Operation with main system clock	V _{DD} = 4.75 to 6.0 V	0.67		64	μs
				2.6		64	μs
		Operation with subsystem clock	114	122	125	μs	
TIO input frequency	f _{ri}	V _{DD} = 4.5 to 6.0 V	0		1	MHz	
			0		275	kHz	
TIO input high and low-level widths	t _{TIH} , t _{TIL}	V _{DD} = 4.5 to 6.0 V	0.48			μs	
			1.8			μs	
Interrupt input high and low-level widths	t _{INTH} , t _{INTL}	INT0	*2			μs	
		INT1, 2, 4	10			μs	
RESET low level widths	t _{RSL}		10			μs	

- * 1. CPU clock (ϕ) cycle time is determined by the oscillator for frequency of the connected oscillator, the system clock control register (SCC) and processor clock control register (PCC). The cycle time t_{cy} characteristics for supply voltage V_{DD} when the main system clock is in operation is shown on the right.
- 2. 2t_{cy} or 128/f_x is set by interrupt mode register (IM0) setting.

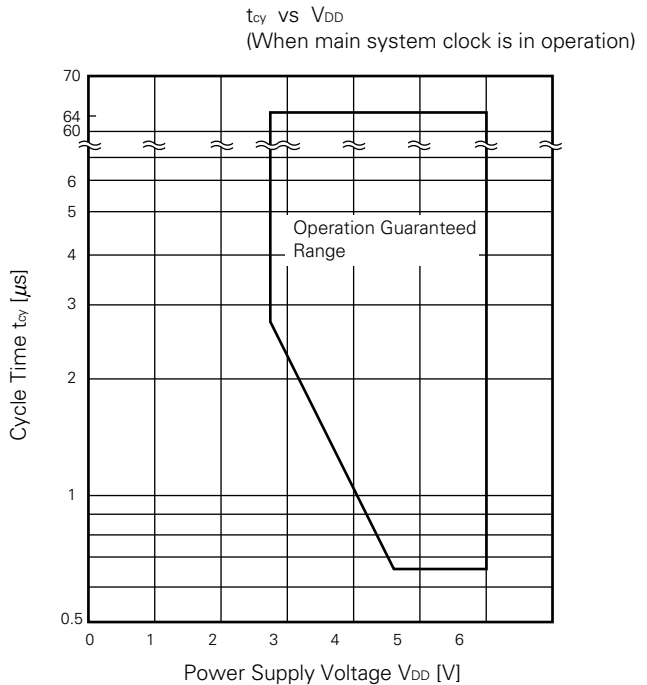

(2) Serial Transfer Operation

(a) 2-Wired and 3-Wired Serial I/O Modes ($\overline{\text{SCK}}$... Internal clock output)

PARAMETER	SYMBOL	TEST CONDITIONS		MIN.	TYP.	MAX.	UNIT
$\overline{\text{SCK}}$ cycle time	t_{KCY1}	$V_{\text{DD}} = 4.5 \text{ to } 6.0 \text{ V}$	$f_x = 6.0 \text{ MHz}$	1340			ns
			$f_x = 4.19 \text{ MHz}$	1600			ns
			$f_x = 6.0 \text{ MHz}$	2680			ns
			$f_x = 4.19 \text{ MHz}$	3800			ns
$\overline{\text{SCK}}$ high and low level widths	t_{KL1} t_{KH1}	$V_{\text{DD}} = 4.5 \text{ to } 6.0 \text{ V}$		$(t_{\text{KCY1}}/2)$ -50			ns
				$(t_{\text{KCY1}}/2)$ -150			ns
SI setup time (to $\overline{\text{SCK}}\uparrow$)	t_{SIK1}			150			ns
SI hold time (from $\overline{\text{SCK}}\uparrow$)	t_{KSI1}			400			ns
SO output delay time from $\overline{\text{SCK}}\downarrow$	t_{KSO1}	$R_L = 1 \text{ k}\Omega$, $C_L = 100 \text{ pF}^*$	$V_{\text{DD}} = 4.5$ to 6.0 V			250	ns
						1000	ns

* R_L and C_L denote load resistor and load capacitance of SO output line.

(b) 2-Wired and 3-Wired Serial I/O Modes ($\overline{\text{SCK}}$... External clock input)

PARAMETER	SYMBOL	TEST CONDITIONS		MIN.	TYP.	MAX.	UNIT
$\overline{\text{SCK}}$ cycle time	t_{KCY2}	$V_{\text{DD}} = 4.5 \text{ to } 6.0 \text{ V}$		800			ns
				3200			ns
$\overline{\text{SCK}}$ high and low level widths	t_{KL2} t_{KH2}	$V_{\text{DD}} = 4.5 \text{ to } 6.0 \text{ V}$		400			ns
				1600			ns
SI setup time (to $\overline{\text{SCK}}\uparrow$)	t_{SIK2}			100			ns
SI hold time (from $\overline{\text{SCK}}\uparrow$)	t_{KSI2}			400			ns
SO output delay time from $\overline{\text{SCK}}\downarrow$	t_{KSO2}	$R_L = 1 \text{ k}\Omega$, $C_L = 100 \text{ pF}^*$	$V_{\text{DD}} = 4.5$ to 6.0 V			300	ns
						1000	ns

* R_L and C_L denote load resistor and load capacitance of SO output line.

(c) SBI Mode ($\overline{\text{SCK}}$... Internal clock output (Master))

PARAMETER	SYMBOL	TEST CONDITIONS		MIN.	TYP.	MAX.	UNIT
$\overline{\text{SCK}}$ cycle time	t_{KCY3}	$V_{\text{DD}} = 4.5 \text{ to } 6.0 \text{ V}$	$f_x = 6.0 \text{ MHz}$	1340			ns
			$f_x = 4.19 \text{ MHz}$	1600			ns
			$f_x = 6.0 \text{ MHz}$	2680			ns
			$f_x = 4.19 \text{ MHz}$	3800			ns
$\overline{\text{SCK}}$ high and low level widths	t_{KL3} t_{KH3}	$V_{\text{DD}} = 4.5 \text{ to } 6.0 \text{ V}$		$t_{\text{KCY3}}/2-50$			ns
				$t_{\text{KCY3}}/2-150$			ns
SB0, 1 setup time (to $\overline{\text{SCK}} \uparrow$)	t_{SIK3}			150			ns
SB0, 1 hold time (from $\overline{\text{SCK}} \uparrow$)	t_{KS13}			$t_{\text{KCY3}}/2$			ns
SB0, 1 output delay time from $\overline{\text{SCK}} \downarrow$	t_{KSO3}	$R_L = 1 \text{ k}\Omega$, $C_L = 100 \text{ pF}^*$	$V_{\text{DD}} = 4.5 \text{ to } 6.0 \text{ V}$	0		250	ns
				0		1000	ns
SB0, 1 \downarrow from $\overline{\text{SCK}} \uparrow$	t_{KSB}			t_{KCY3}			ns
$\overline{\text{SCK}}$ from SB0, 1 \downarrow	t_{SBK}			t_{KCY3}			ns
SB0, 1 low level widths	t_{SBL}			t_{KCY3}			ns
SB0, 1 high level widths	t_{SBH}			t_{KCY3}			ns

* R_L and C_L denote load resistor and load capacitance of SO output lines.

(d) SBI Mode ($\overline{\text{SCK}}$... External clock input (Slave))

PARAMETER	SYMBOL	TEST CONDITIONS		MIN.	TYP.	MAX.	UNIT
$\overline{\text{SCK}}$ cycle time	t _{KCY4}	V _{DD} = 4.5 to 6.0 V		800			ns
				3200			ns
$\overline{\text{SCK}}$ high and low level widths	t _{KL4} t _{KH4}	V _{DD} = 4.5 to 6.0 V		400			ns
				1600			ns
SB0, 1 setup time (to $\overline{\text{SCK}}$ ↑)	t _{SIK4}			100			ns
SB0, 1 hold time (from $\overline{\text{SCK}}$ ↑)	t _{KSI4}			t _{KCY4} /2			ns
SB0, 1 output delay time from $\overline{\text{SCK}}$ ↓	t _{KSO4}	R _L = 1 kΩ C _L = 100 pF*	V _{DD} = 4.5 to 6.0 V	0		300	ns
				0		1000	ns
SB0, 1 ↓ from $\overline{\text{SCK}}$ ↑	t _{KSB}			t _{KCY4}			ns
$\overline{\text{SCK}}$ ↓ from SB0, 1 ↓	t _{SBK}			t _{KCY4}			ns
SB0, 1 low level widths	t _{SBL}			t _{KCY4}			ns
SB0, 1 high level widths	t _{SBH}			t _{KCY4}			ns

* R_L and C_L denote load resistor and load capacitance of SO output lines.

AC Timing Test Points (Except X1 and XT1 Inputs)



Clock Timings

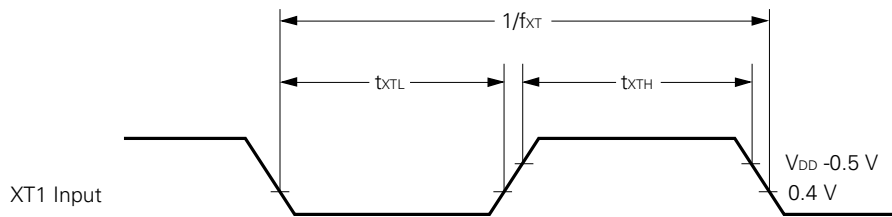
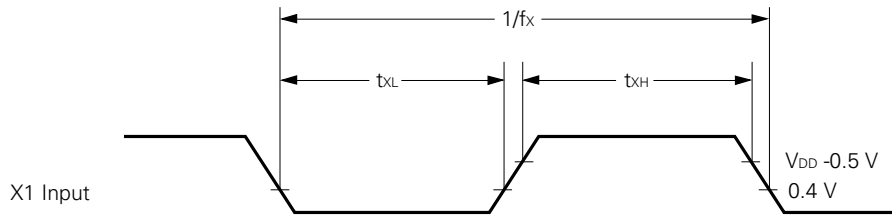

T10 Timing

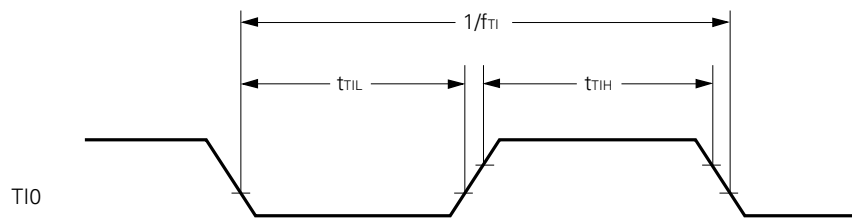

Serial Transfer Timing

3-wired serial I/O mode:

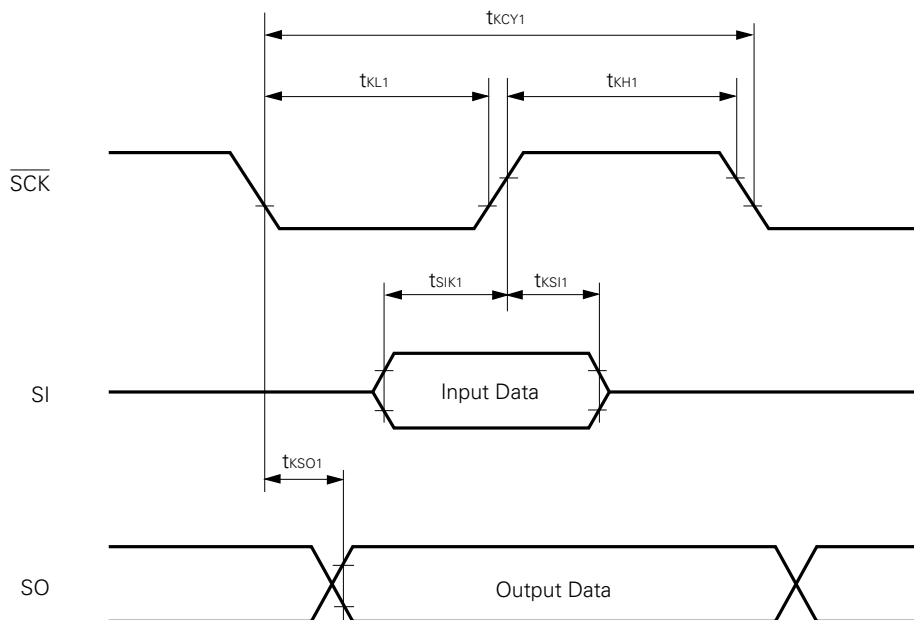

2-wired serial I/O mode:

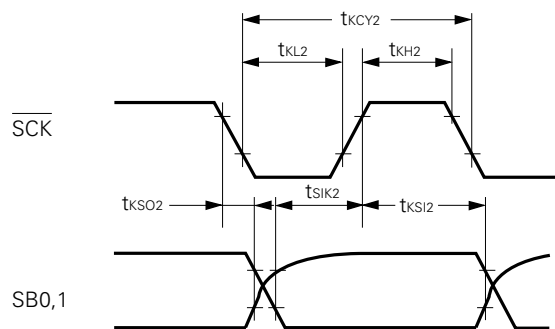

Serial Transfer Timing

Bus release signal transfer:

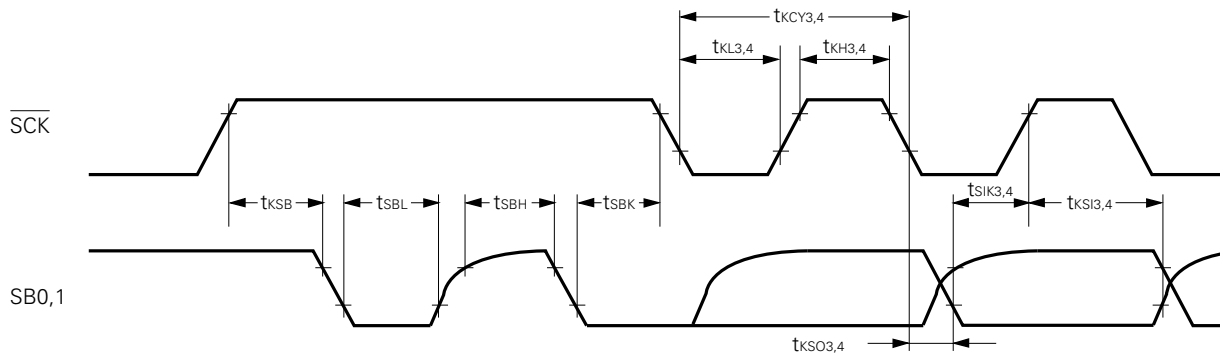

Command signal transfer:

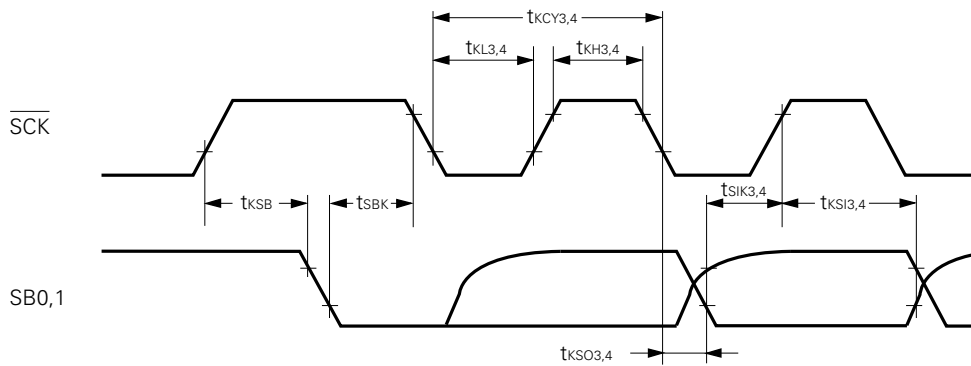

Interrupt Input Timing

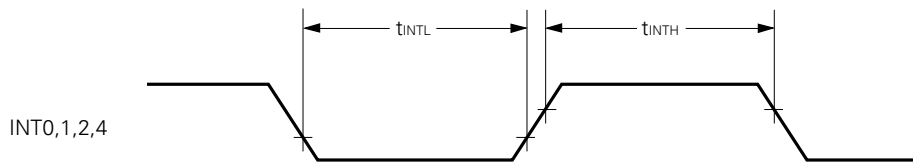

RESET Input Timing

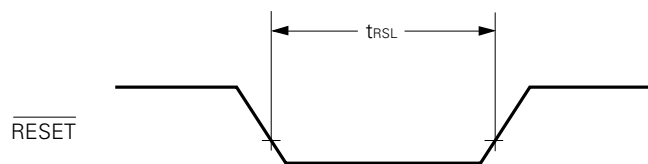

DATA MEMORY STOP MODE LOW SUPPLY VOLTAGE DATA RETENTION CHARACTERISTICS (Ta = -40 to 70 °C)

PARAMETER	SYMBOL	TEST CONDITIONS	MIN.	TYP.	MAX.	UNIT
Data retention power supply voltage	V _{DDDR}		2.0		6.0	V
Data retention power supply current*1	I _{DDDR}	V _{DDDR} = 2.0 V		0.1	10	μA
Release signal set time	t _{SREL}		0			μs
Oscillation stabilization wait time*2	t _{WAIT}	Release by <u>RESET</u>		2 ¹⁷ /fx		ms
		Release by interrupt request		*3		ms

- * 1. Current to the on-chip pull-up resistor and power-on reset circuit (mask option) is not included.
- 2. Oscillation stability wait time is time to stop CPU operation to prevent unstable operation upon oscillation start.
- 3. According to the setting of the basic interval timer mode register (BTM). (see below)

BTM3	BTM2	BTM1	BTM0	Wait Time	
				Values at fx = 6.0 MHz in Parentheses	Values at fx = 4.19 MHz in Parentheses
—	0	0	0	2 ²⁰ /fx (approx. 175 ms)	2 ²⁰ /fx (approx. 250 ms)
—	0	1	1	2 ¹⁷ /fx (approx. 21.8 ms)	2 ¹⁷ /fx (approx. 31.3 ms)
—	1	0	1	2 ¹⁵ /fx (approx. 5.46 ms)	2 ¹⁵ /fx (approx. 7.82 ms)
—	1	1	1	2 ¹³ /fx (approx. 1.37 ms)	2 ¹³ /fx (approx. 1.95 ms)

Data Retention Timing (STOP mode release by RESET)

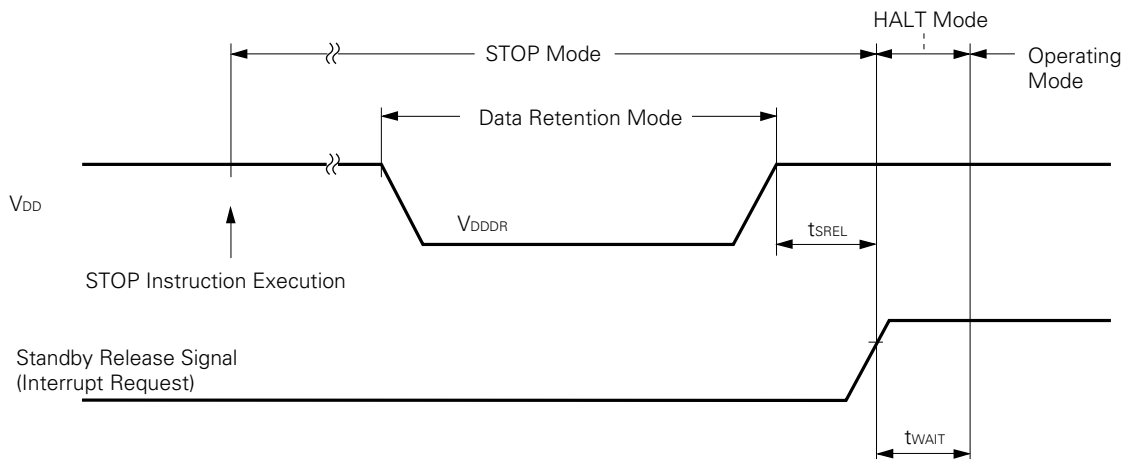

Data Retention Timing (Standby release signal: STOP mode release by interrupt signal)

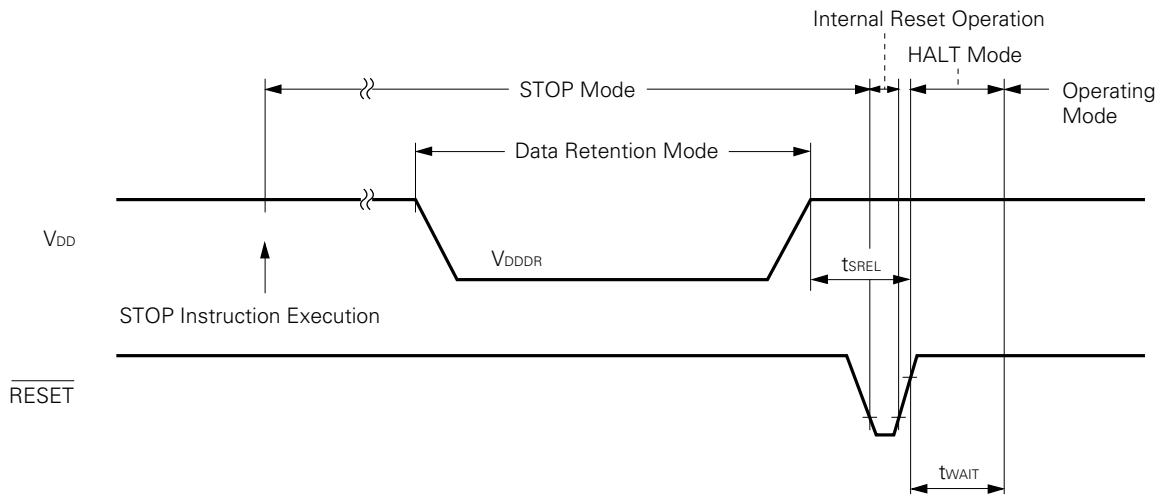

DC PROGRAMMING CHARACTERISTICS (Ta = 25 ±5 °C, VDD = 6.0 ±0.25 V, VPP = 12.5 ±0.3 V, VSS = 0 V)

PARAMETER	SYMBOL	TEST CONDITIONS	MIN.	TYP.	MAX.	UNIT
Input voltage high	V _{IH1}	Except X1 and X2	0.7 V _{DD}		V _{DD}	V
	V _{IH2}	X1, X2	V _{DD} -0.5		V _{DD}	V
Input voltage low	V _{IL1}	Except X1 and X2	0		0.3 V _{DD}	V
	V _{IL2}	X1, X2	0		0.4	V
Input leakage current	I _{LI}	V _{IN} = V _{IL} or V _{IH}			10	μA
Output voltage high	V _{OH}	I _{OH} = -1 mA	V _{DD} -1.0			V
Output voltage low	V _{OL}	I _{OH} = 1.6 mA			0.4	V
V _{DD} supply current	I _{DD}				30	mA
V _{PP} supply current	I _{PP}	MD0 = V _{IL} , MD1 = V _{IH}			30	mA

- Note**
1. V_{PP}, including overshoot, should not exceed +13.5 V.
 2. V_{DD} should be applied before V_{PP} and cut after V_{PP}.

AC PROGRAMMING CHARACTERISTICS (Ta = 25 ±5 °C, VDD = 6.0 ±0.25 V, VPP = 12.5 ±0.3 V, VSS = 0 V) (1/2)

PARAMETER	SYMBOL	*1	TEST CONDITIONS	MIN.	TYP.	MAX.	UNIT
Address setup time*2 (to MD0 ↓)	t _{AS}	t _{AS}		2			μs
MD1 setup time (to MD0 ↓)	t _{M1S}	t _{OES}		2			μs
Data setup time (to MD0 ↓)	t _{DS}	t _{DS}		2			μs
Address hold time*2 (from MD0 ↑)	t _{AH}	t _{AH}		2			μs
Data hold time (from MD0 ↑)	t _{DH}	t _{DH}		2			μs
Data output float delay time from MD0 ↑	t _{DF}	t _{DF}		0		130	ns
V _{PP} setup time (to MD3 ↑)	t _{VPS}	t _{VPS}		2			μs
V _{DD} setup time (to MD3 ↑)	t _{VDS}	t _{VCS}		2			μs
Initial program pulse widths	t _{PW}	t _{PW}		0.95	1.0	1.05	ms
Additional program pulse widths	t _{OPW}	t _{OPW}		0.95		21.0	ms
MD0 setup time (to MD1 ↑)	t _{MOS}	t _{CES}		2			μs
Data output delay time from MD0 ↓	t _{DV}	t _{DV}	MD0 = MD1 = V _{IL}			1	μs

- * 1. The corresponding μPD27C256 symbol.
2. Internal address signal is incremented by one on the rise of fourth X1 input and is not connected to the pin.

AC PROGRAMMING CHARACTERISTICS (Ta = 25 ±5 °C, VDD = 6.0 ±0.25 V, VPP = 12.5 ±0.3 V, VSS = 0 V) (2/2)

PARAMETER	SYMBOL	*1	TEST CONDITIONS	MIN.	TYP.	MAX.	UNIT
MD1 hold time (from MD0 ↑)	tM1H	tOEH	tM1H + tM1R ≥ 50 μs	2			μs
MD1 recovered time (to MD0 ↓)	tM1R	tOR		2			μs
Program counter reset time	tPCR	—		10			μs
X1 input high and low level widths	tXH, tXL	—		0.125			μs
X1 input frequency	fX	—				4.19	MHz
Initial mode set time	tI	—		2			μs
MD3 setup time (to MD1 ↑)	tM3S	—		2			μs
MD3 hold time (from MD1 ↓)	tM3H	—		2			μs
MD3 setup time (to MD0 ↓)	tM3SR	—	When reading program memory	2			μs
Data output delay time from address*2	tDAD	tACC	When reading program memory	2			μs
Data output hold time from address*2	tHAD	tOH	When reading program memory	0		130	ns
MD3 hold time (from MD0 ↑)	tM3HR	—	When reading program memory	2			μs
Data output float delay time from MD3 ↓	tDFR	—	When reading program memory	2			μs

- * 1. The corresponding μPD27C256 symbol.
- 2. Internal address signal is incremented by one on the rise of fourth X1 input and is not connected to the pin.

Write Timing of Program Memory

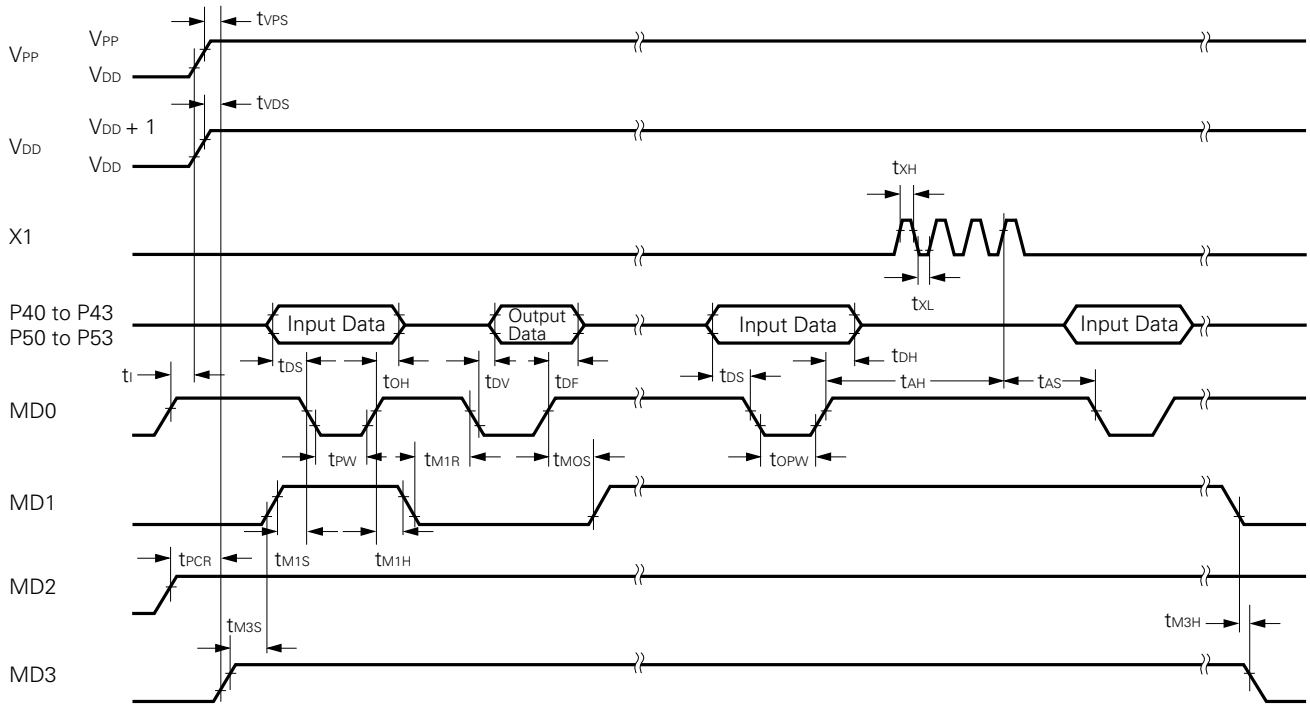

Read Timing of Program Memory

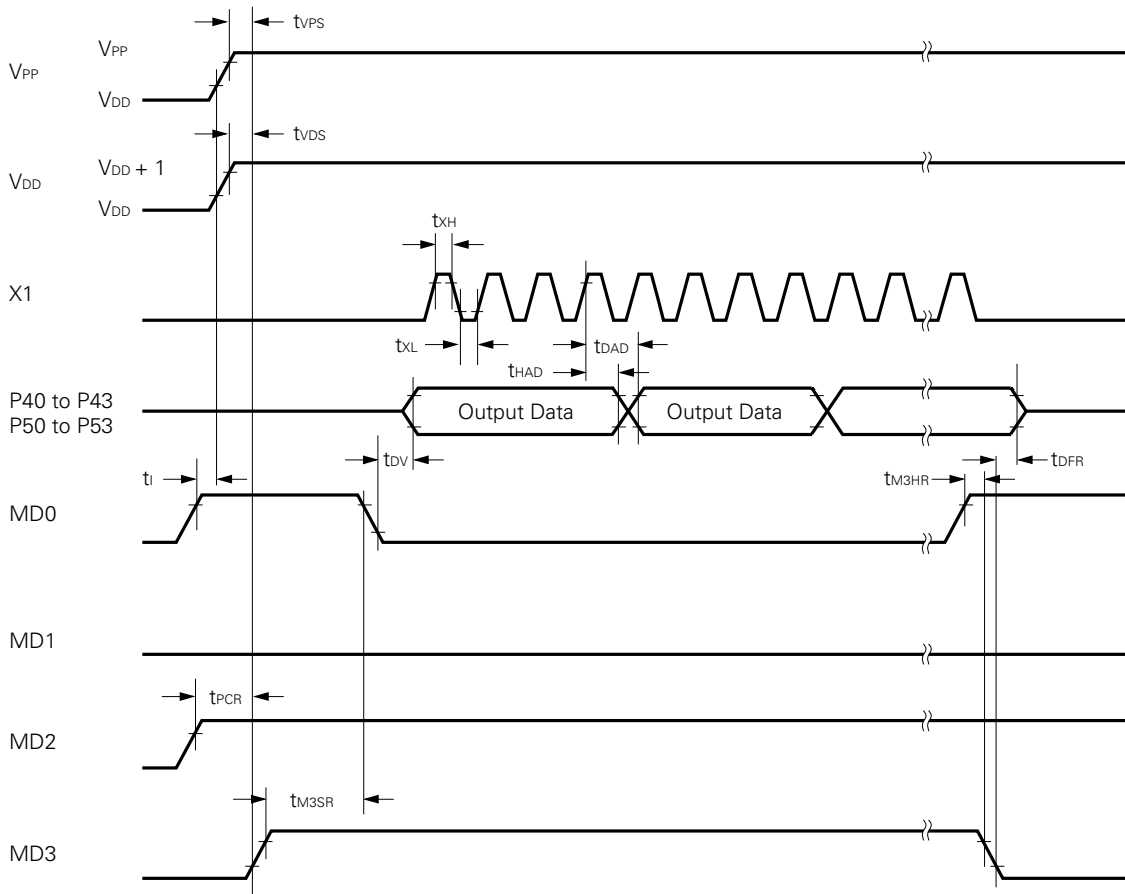

7. PACKAGE INFORMATION

94 PIN PLASTIC QFP (□20)

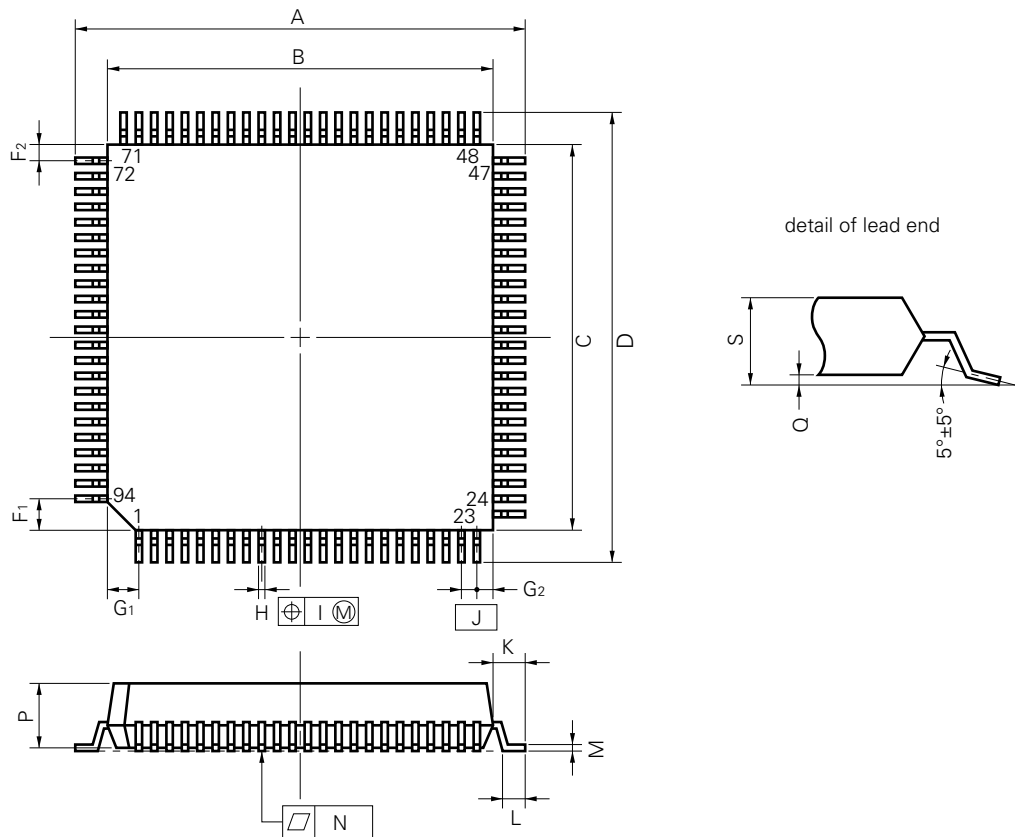

NOTE

Each lead centerline is located within 0.15 mm (0.006 inch) of its true position (T.P.) at maximum material condition.

S94GJ-80-5BG-2

ITEM	MILLIMETERS	INCHES
A	23.2±0.4	0.913 ^{+0.017} _{-0.016}
B	20.0±0.2	0.787 ^{+0.009} _{-0.008}
C	20.0±0.2	0.787 ^{+0.009} _{-0.008}
D	23.2±0.4	0.913 ^{+0.017} _{-0.016}
F ₁	1.6	0.063
F ₂	0.8	0.031
G ₁	1.6	0.063
G ₂	0.8	0.031
H	0.35±0.10	0.014 ^{+0.004} _{-0.005}
I	0.15	0.006
J	0.8 (T.P.)	0.031 (T.P.)
K	1.6±0.2	0.063±0.008
L	0.8±0.2	0.031 ^{+0.009} _{-0.008}
M	0.15 ^{+0.10} _{-0.05}	0.006 ^{+0.004} _{-0.003}
N	0.12	0.005
P	3.7	0.146
Q	0.1±0.1	0.004±0.004
S	4.0 MAX.	0.158 MAX.

94 PIN CERAMIC WQFN

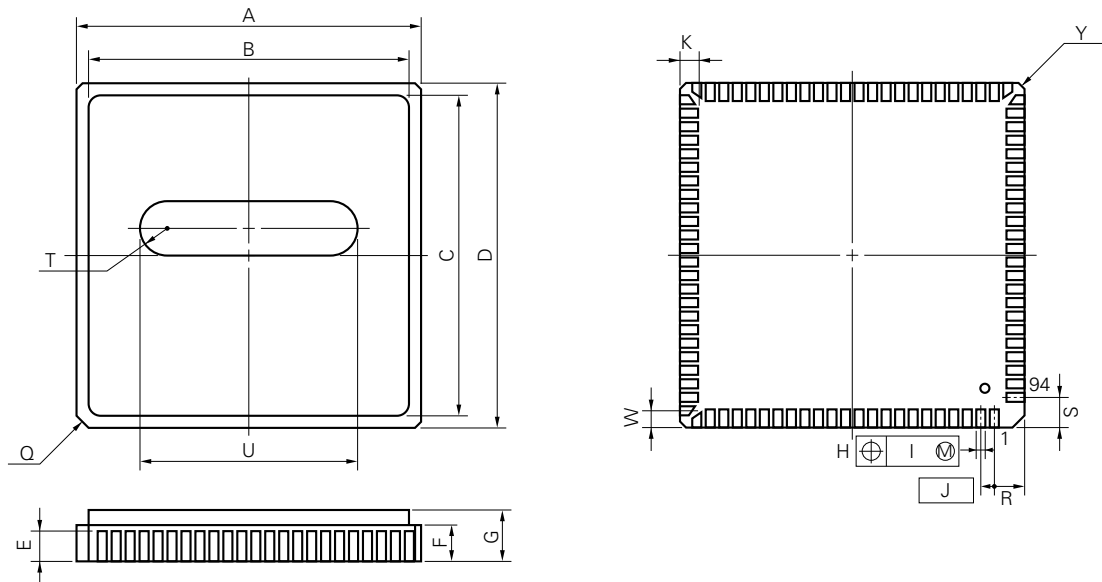

NOTE

Each lead centerline is located within 0.08 mm (0.003 inch) of its true position (T.P.) at maximum material condition.

X94KW-80A-1

ITEM	MILLIMETERS	INCHES
A	20.0±0.4	0.787 ^{+0.017} _{-0.016}
B	18.0	0.709
C	18.0	0.709
D	20.0±0.4	0.787 ^{+0.017} _{-0.016}
E	1.94	0.076
F	2.14	0.084
G	4.064 MAX.	0.160 MAX.
H	0.51±0.10	0.020±0.004
I	0.08	0.003
J	0.8 (T.P.)	0.031 (T.P.)
K	1.0±0.2	0.039 ^{+0.009} _{-0.008}
Q	C 1.0	C 0.039
R	1.6	0.063
S	1.6	0.063
T	R 1.75	0.069
U	11.5	0.453
W	0.75±0.2	0.030 ^{+0.008} _{-0.009}

8. RECOMMENDED SOLDERING CONDITIONS



This product should be soldered and mounted under the conditions recommended in the table below.

For details of recommended soldering conditions, refer to the **information document "Surface Mount Technology Manual" (IEI-1207)**.

For soldering methods and conditions other than those recommended below, contact our salesman.

Table 8-1 Surface Mount Type Soldering Conditions

μPD75P238GJ-xxx-5BG : 94-pin plastic QFP (□20 mm)

Soldering Method	Soldering Conditions	Recommended Condition Symbol
Infrared reflow	Package peak temperature: 230 °C, Duration: 30 sec. max. (at 210 °C or above); Number of times: Once, Time limit: 7 days* (125 °C prebaking requires 10 hours thereafter)	IR30-107-1
VPS	Package peak temperature: 215 °C, Duration: 40 sec. max. (at 200 °C or above); Number of times: Once, Time limit: 7 days* (125 °C prebaking requires 10 hours thereafter)	VP15-107-1
Pin part heating	Pin part temperature: 300 °C max.; Duration: 3 sec. max., (per device side)	—

* For the storage period after dry-pack decapsulation, storage conditions are max. 25 °C, 65% RH.

Note Use of more than one soldering method should be avoided (except in the case of pin part heating).

APPENDIX A. DEVELOPMENT TOOLS

The following support tools are available for system development using the μPD75P238.

Hardware	IE-75000-R*1 IE-75001-R	75X series in-circuit emulator
	IE-75000-R-EM*2	IE-75000-R/IE-75001-R emulation board
	EP-75238GJ-R	μPD75P238 emulation probe
	EV-9200G-94	94-pin conversion socket EV-9200G-94 is provided
	PG-1500	PROM programmer
	PA-75P238GJ	PG-1500 connected with μPD75P238GJ PROM program adapter
PA-75P238KF	PG-1500 connected with μPD75P238KF PROM program adapter	
Software	IE control program	Host machine
	PG-1500 controller	PC-9800 series (MS-DOS™ Ver.3.30 to Ver.5.00A*3)
	RA75X relocatable assembler	IBM PC/AT™ (PC DOS™ Ver.3.1)

- * 1. Maintenance product
- 2. Not incorporated in IE-75001-R
- 3. The task swap function, which is provided with Ver.5.00/5.00A. is not available with this software.

Remarks For development tools manufactured by a third party, see the "75X Series Selection Guide" (IF-151).

APPENDIX B. RELATED DOCUMENTS



Device Related Documents

Document Name	Document No.
User's Manual	
Instruction Application Table	
75X Series Selection Guide	

Development Tools Related Documents

Document Name	Document No.	
Hardware	IE-75000-R/IE-75001-R User's Manual	
	IE-75000-R-EM User's Manual	
	EP-75238GJ-R User's Manual	
	PG-1500 User's Manual	
Software	RA75X Assembler Package User's Manual	Operation Volume
		Language Volume
	PG-1500 Controller User's Manual	

Other Documents

Document Name	Document No.
Package Manual	
Surface Mount Technology Manual	
Quality Grade on NEC Semiconductor Devices	
NEC Semiconductor Device Reliability & Quality Control	
Electrostatic Discharge (ESD) Test	
Semiconductor Devices Quality Guarantee Guide	
Microcomputer Related Products Guide Other Manufactures Volume	

Note The contents of the above related documents are subjected to change without notice. The latest documents should be used for design, etc.

[MEMO]

No part of this document may be copied or reproduced in any form or by any means without the prior written consent of NEC Corporation. NEC Corporation assumes no responsibility for any errors which may appear in this document.

NEC Corporation does not assume any liability for infringement of patents, copyrights or other intellectual property rights of third parties by or arising from use of a device described herein or any other liability arising from use of such device. No license, either express, implied or otherwise, is granted under any patents, copyrights or other intellectual property rights of NEC Corporation or others.

The devices listed in this document are not suitable for use in aerospace equipment, submarine cables, nuclear reactor control systems and life support systems. If customers intend to use NEC devices for above applications or they intend to use "Standard" quality grade NEC devices for applications not intended by NEC, please contact our sales people in advance.

Application examples recommended by NEC Corporation

Standard : Computer, Office equipment, Communication equipment, Test and Measurement equipment,
Machine tools, Industrial robots, Audio and Visual equipment, Other consumer products, etc.
Special : Automotive and Transportation equipment, Traffic control systems, Antidisaster systems,
Anticrime systems, etc.

FIP is a trademark of NEC Corporation.

MS-DOS is a trademark of MicroSoft Corporation.

PC DOS, PC/AT are trademarks of IBM Corporation.

M4 92.6