

## OP282/OP482

### FEATURES

High Slew Rate: 9 V/ $\mu$ s  
 Wide Bandwidth: 4 MHz  
 Low Supply Current: 250  $\mu$ A/Amplifier  
 Low Offset Voltage: 3 mV  
 Low Bias Current: 100 pA  
 Fast Settling Time  
 Common-Mode Range Includes V+  
 Unity Gain Stable

### APPLICATIONS

Active Filters  
 Fast Amplifiers  
 Integrators  
 Supply Current Monitoring

### GENERAL DESCRIPTION

The OP282/OP482 dual and quad operational amplifiers feature excellent speed at exceptionally low supply currents. Slew rate exceeds 7 V/ $\mu$ s with supply current under 250  $\mu$ A per amplifier. These unity gain stable amplifiers have a typical gain bandwidth of 4 MHz.

The JFET input stage of the OP282/OP482 insures bias current is typically a few picoamps and below 500 pA over the full temperature range. Offset voltage is under 3 mV for the dual and under 4 mV for the quad.

With a wide output swing, within 1.5 volts of each supply, low power consumption and high slew rate, the OP282/OP482 are ideal for battery-powered systems or power restricted applications. An input common-mode range that includes the positive supply makes the OP282/OP482 an excellent choice for high-side signal conditioning.

The OP282/OP482 are specified over the extended industrial temperature range. Both dual and quad amplifiers are available in plastic and ceramic DIP plus SOIC surface mount packages.

### PIN CONNECTIONS

8-Lead Narrow-Body SOIC (S Suffix)

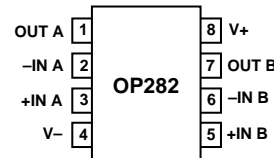

8-Lead Epoxy DIP (P Suffix)

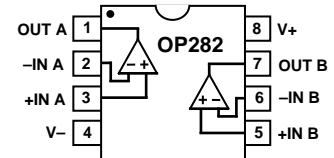

14-Lead Epoxy DIP (P Suffix)

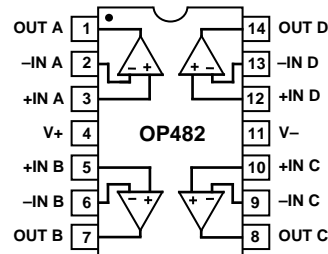

14-Lead Narrow-Body SOIC (S Suffix)

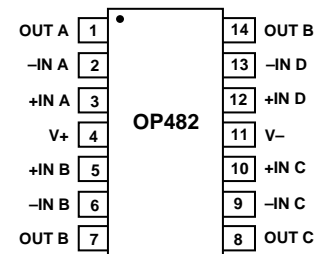

REV. B

Information furnished by Analog Devices is believed to be accurate and reliable. However, no responsibility is assumed by Analog Devices for its use, nor for any infringements of patents or other rights of third parties which may result from its use. No license is granted by implication or otherwise under any patent or patent rights of Analog Devices.

# OP282/OP482–SPECIFICATIONS

## ELECTRICAL CHARACTERISTICS (@ $V_S = \pm 15.0\text{ V}$ , $T_A = +25^\circ\text{C}$ unless otherwise noted)

Parameter	Symbol	Conditions	Min	Typ	Max	Units
<b>INPUT CHARACTERISTICS</b>						
Offset Voltage	$V_{OS}$	OP282		0.2	3	mV
Offset Voltage	$V_{OS}$	OP282, $-40 \leq T_A \leq +85^\circ\text{C}$			4.5	mV
Offset Voltage	$V_{OS}$	OP482		0.2	4	mV
Offset Voltage	$V_{OS}$	OP482, $-40 \leq T_A \leq +85^\circ\text{C}$			6	mV
Input Bias Current	$I_B$	$V_{CM} = 0\text{ V}$		3	100	pA
Input Bias Current	$I_B$	$V_{CM} = 0\text{ V}$ , Note 1			500	pA
Input Offset Current	$I_{OS}$	$V_{CM} = 0\text{ V}$		1	50	pA
Input Offset Current	$I_{OS}$	$V_{CM} = 0\text{ V}$ , Note 1			250	pA
Input Voltage Range			-11		+15	V
Common-Mode Rejection	CMR	$-11\text{ V} \leq V_{CM} \leq +15\text{ V}$ , $-40 \leq T_A \leq +85^\circ\text{C}$	70	90		dB
Large Signal Voltage Gain	$A_{VO}$	$R_L = 10\text{ k}\Omega$	20			V/mV
Large Signal Voltage Gain	$A_{VO}$	$R_L = 10\text{ k}\Omega$ , $-40 \leq T_A \leq +85^\circ\text{C}$	15			V/mV
Offset Voltage Drift	$\Delta V_{OS}/\Delta T$			10		$\mu\text{V}/^\circ\text{C}$
Bias Current Drift	$\Delta I_B/\Delta T$			8		$\text{pA}/^\circ\text{C}$
<b>OUTPUT CHARACTERISTICS</b>						
Output Voltage Swing	$V_O$	$R_L = 10\text{ k}\Omega$	-13.5	$\pm 13.9$	13.5	V
Short Circuit Limit	$I_{SC}$	Source	3	10		mA
Short Circuit Limit	$I_{SC}$	Sink	-8	-12		mA
Open-Loop Output Impedance	$Z_{OUT}$	$f = 1\text{ MHz}$		200		$\Omega$
<b>POWER SUPPLY</b>						
Power Supply Rejection Ratio	PSRR	$V_S = \pm 4.5\text{ V}$ to $\pm 18\text{ V}$ , $-40 \leq T_A \leq +85^\circ\text{C}$		25	316	$\mu\text{V}/\text{V}$
Supply Current/Amplifier	$I_{SY}$	$V_O = 0\text{ V}$ , $40 \leq T_A \leq +85^\circ\text{C}$		210	250	$\mu\text{A}$
Supply Voltage Range	$V_S$		$\pm 4.5$		$\pm 18$	V
<b>DYNAMIC PERFORMANCE</b>						
Slew Rate	SR	$R_L = 10\text{ k}\Omega$	7	9		$\text{V}/\mu\text{s}$
Full-Power Bandwidth	$BW_P$	1% Distortion		125		kHz
Settling Time	$t_s$	To 0.01%		1.6		$\mu\text{s}$
Gain Bandwidth Product	GBP			4		MHz
Phase Margin	$\angle O$			55		Degrees
<b>NOISE PERFORMANCE</b>						
Voltage Noise	$e_n$ p-p	0.1 Hz to 10 Hz		1.3		$\mu\text{V p-p}$
Voltage Noise Density	$e_n$	$f = 1\text{ kHz}$		36		$\text{nV}/\sqrt{\text{Hz}}$
Current Noise Density	$i_n$			0.01		$\text{pA}/\sqrt{\text{Hz}}$

### NOTE

<sup>1</sup>The input bias and offset currents are tested at  $T_A = T_J = +85^\circ\text{C}$ . Bias and offset currents are guaranteed but not tested at  $-40^\circ\text{C}$ .

Specifications subject to change without notice.

## WAFER TEST LIMITS (@ $V_S = \pm 15.0\text{ V}$ , $T_A = +25^\circ\text{C}$ unless otherwise noted)

Parameter	Symbol	Conditions	Limit	Units
Offset Voltage	$V_{OS}$	OP282	3	mV max
Offset Voltage	$V_{OS}$	OP482	4	mV max
Input Bias Current	$I_B$	$V_{CM} = 0\text{ V}$	100	pA max
Input Offset Current	$I_{OS}$	$V_{CM} = 0\text{ V}$	50	pA max
Input Voltage Range <sup>1</sup>			-11, +15	V min/max
Common-Mode Rejection	CMRR	$-11\text{ V} \leq V_{CM} \leq +15\text{ V}$	70	dB min
Power Supply Rejection Ratio	PSRR	$V = \pm 4.5\text{ V}$ to $\pm 18\text{ V}$	316	$\mu\text{V}/\text{V}$
Large Signal Voltage Gain	$A_{VO}$	$R_L = 10\text{ k}\Omega$	20	V/mV min
Output Voltage Range	$V_O$	$R_L = 10\text{ k}\Omega$	$\pm 13.5$	V min
Supply Current/Amplifier	$I_{SY}$	$V_O = 0\text{ V}$ , $R_L = \infty$	250	$\mu\text{A}$ max

### NOTES

Electrical tests and wafer probe to the limits shown. Due to variations in assembly methods and normal yield loss, yield after packaging is not guaranteed for standard product dice. Consult factory to negotiate specifications based on dice lot qualifications through sample lot assembly and testing.

<sup>1</sup>Guaranteed by CMR test.

Specifications subject to change without notice.

**ABSOLUTE MAXIMUM RATINGS**

Supply Voltage ..... ±18 V  
 Input Voltage<sup>1</sup> ..... ±18 V  
 Differential Input Voltage<sup>1</sup> ..... 36 V  
 Output Short-Circuit Duration ..... Indefinite  
 Storage Temperature Range  
   P, S Packages ..... -65°C to +150°C  
 Operating Temperature Range  
   OP282A, OP482A ..... -55°C to +125°C  
   OP282G, OP482G ..... -40°C to +85°C  
 Junction Temperature Range  
   P, S Packages ..... -65°C to +125°C  
 Lead Temperature Range (Soldering, 60 sec) ..... +300°C

Package Type	$\theta_{JA}^2$	$\theta_{JC}$	Units
8-Pin Plastic DIP (P)	103	43	°C/W
8-Pin SOIC (S)	158	43	°C/W
14-Pin Plastic DIP (P)	83	39	°C/W
14-Pin SOIC (S)	120	36	°C/W

**NOTES**

<sup>1</sup>For supply voltages less than ±18 V, the absolute maximum input voltage is equal to the supply voltage.  
<sup>2</sup> $\theta_{JA}$  is specified for the worst case conditions, i.e.,  $\theta_{JA}$  is specified for device in socket for cerdip, P-DIP;  $\theta_{JA}$  is specified for device soldered in circuit board for SOIC package.

**ORDERING GUIDE**

Model	Temperature Range	Package Description	Package Option
OP282GP	-40°C to +85°C	8-Pin Plastic DIP	N-8
OP282GS	-40°C to +85°C	8-Pin SOIC	SO-8
OP482GP	-40°C to +85°C	14-Pin Plastic DIP	N-14
OP482GS	-40°C to +85°C	14-Pin SOIC	SO-14

**DICE CHARACTERISTICS**

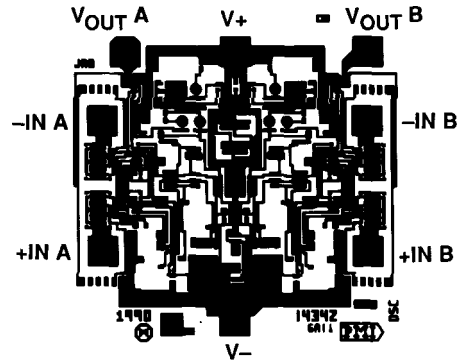

OP282 Die Size 0.063 × 0.060 Inch, 3,780 Sq. Mils

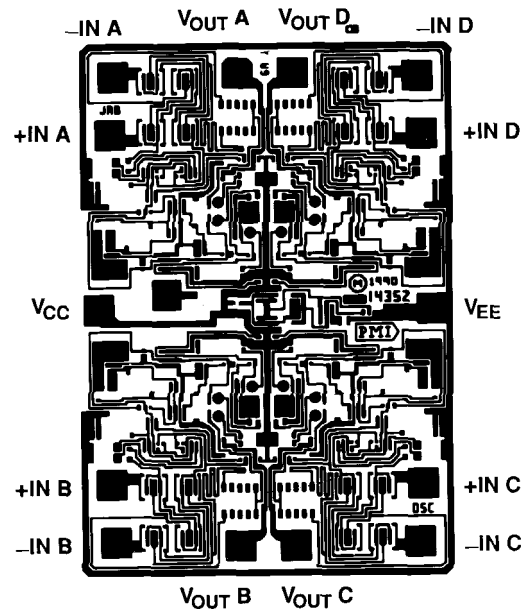

OP482 Die Size 0.070 × 0.098 Inch, 6,860 Sq. Mils

# OP282/OP482

## APPLICATIONS INFORMATION

The OP282 and OP482 are single and dual JFET op amps that have been optimized for high speed at low power. This combination makes these amplifiers excellent choices for battery powered or low power applications requiring above average performance. Applications benefiting from this performance combination include telecom, geophysical exploration, portable medical equipment and navigational instrumentation.

## HIGH SIDE SIGNAL CONDITIONING

There are many applications that require the sensing of signals near the positive rail. OP282s and OP482s have been tested and guaranteed over a common-mode range ( $-11\text{ V} \leq V_{CM} \leq +15\text{ V}$ ) that includes the positive supply.

One application where this is commonly used is in the sensing of power supply currents. This enables it to be used in current sensing applications such as the partial circuit shown in Figure 1. In this circuit, the voltage drop across a low value resistor, such as the  $0.1\ \Omega$  shown here, is amplified and compared to 7.5 volts. The output can then be used for current limiting.

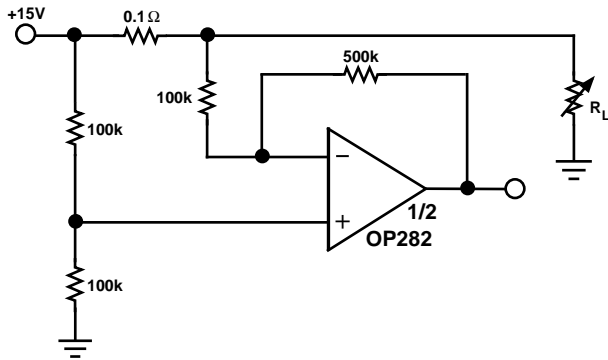

Figure 1. Phase Inversion

## PHASE INVERSION

Most JFET-input amplifiers will invert the phase of the input signal if either input exceeds the input common-mode range. For the OP282 and OP482 negative signals in excess of approximately 14 volts will cause phase inversion. The cause of this effect is saturation of the input stage leading to the forward-biasing of a drain-gate diode. A simple fix for this in noninverting applications is to place a resistor in series with the noninverting input. This limits the amount of current through the forward-biased diode and prevents the shutting down of the output stage. For the OP282/OP482, a value of  $200\text{ k}\Omega$  has been found to work. However, this adds a significant amount of noise.

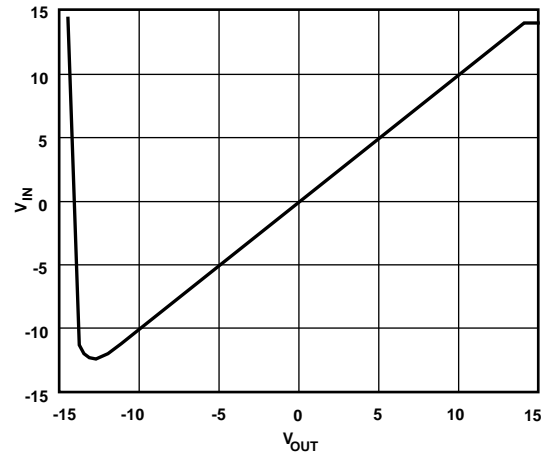

Figure 2. OP282 Phase Reversal

## ACTIVE FILTERS

The OP282 and OP482's wide bandwidth and high slew rates make either an excellent choice for many filter applications.

There are many types of active filter configurations, but the four most popular configurations are Butterworth, elliptical, Bessel, and Chebyshev. Each type has a response that is optimized for a given characteristic as shown in Table I.

## PROGRAMMABLE STATE-VARIABLE FILTER

Table I.

Type	Selectivity	Overshoot	Phase	Amplitude (Pass Band)	Amplitude (Stop Band)
Butterworth	Moderate	Good	Nonlinear	Max Flat	Equal Ripple
Chebyshev	Good	Moderate			
Elliptical	Best	Poor	Linear	Equal Ripple	Equal Ripple
Bessel (Thompson)	Poor	Best			

The circuit shown in Figure 3 can be used to accurately program the “Q,” the cutoff frequency  $f_c$ , and the gain of a two pole state-variable filter. OP482s have been used in this design because of their high bandwidths, low power and low noise. This circuit takes only three packages to build because of the quad configuration of the op amps and DACs.

The DACs shown are all used in the voltage mode so all values are dependent only on the accuracy of the DAC and not on the absolute values of the DAC’s resistive ladders. This make this circuit unusually accurate for a programmable filter.

Adjusting DAC 1 changes the signal amplitude across R1; therefore, the DAC attenuation times R1 determines the amount of signal current that charges the integrating capacitor, C1. This cutoff frequency can now be expressed as:

$$f_c = \frac{1}{2\pi R_1 C_1} \left( \frac{D_1}{256} \right)$$

where  $D_1$  is the digital code for the DAC.

Gain of this circuit is set by adjusting  $D_3$ . The gain equation is:

$$Gain = \frac{R_4}{R_5} \left( \frac{D_3}{256} \right)$$

DAC 2 is used to set the “Q” of the circuit. Adjusting this DAC controls the amount of feedback from the bandpass node to the input summing node. Note that the digital value of the DAC is in the numerator, therefore zero code is not a valid operating point.

$$Q = \frac{R_2}{R_3} \left( \frac{256}{D_2} \right)$$

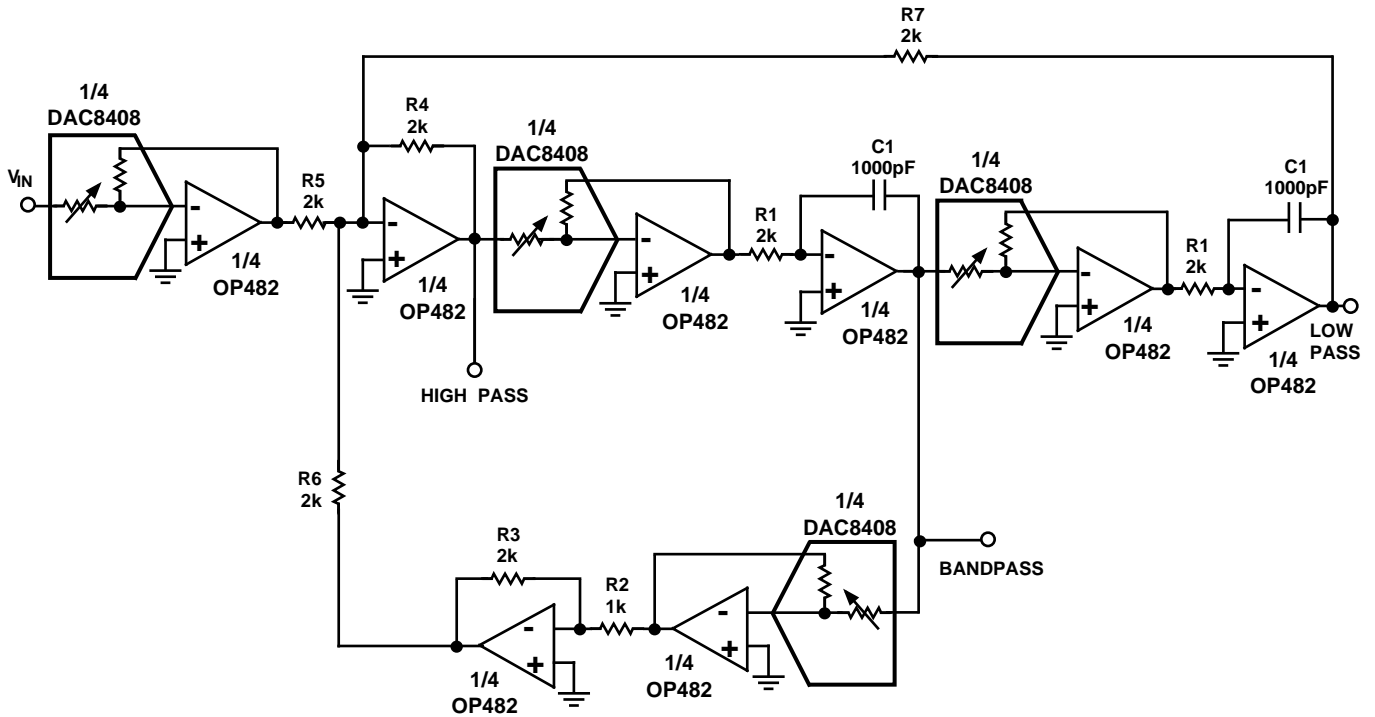

Figure 3.

# OP282/OP482

## OP282/OP482 SPICE MACRO MODEL

Figure 4 shows the OP282 SPICE macro model. The model for the OP482 is similar to that of the OP282, but there are some

minor changes in the circuit values. Contact ADI for a copy of the latest SPICE model diskette for both listings.

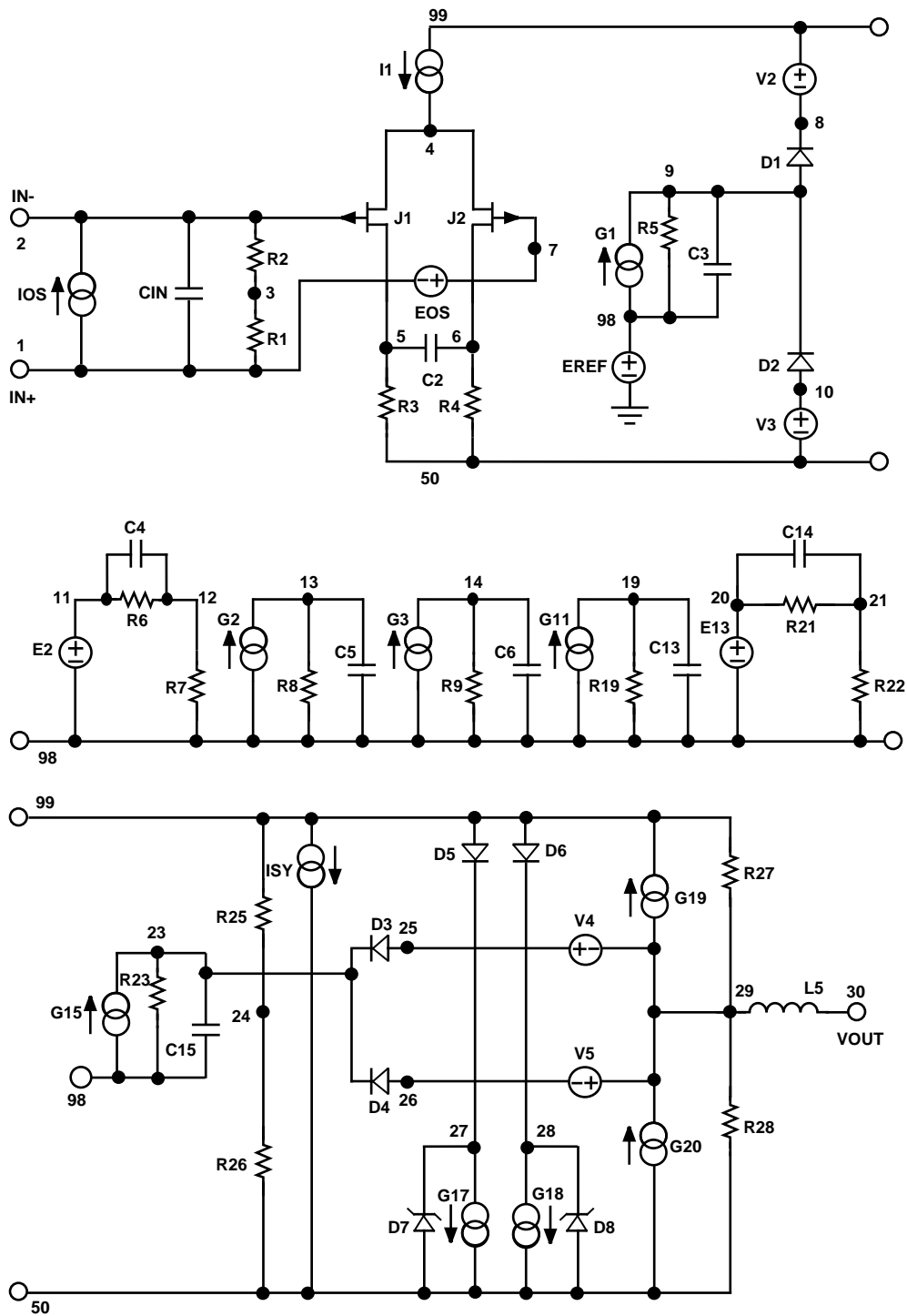
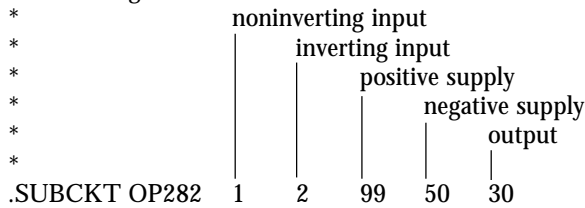

Figure 4.

**OP282 SPICE MACRO MODEL**

\* Node assignments



\* INPUT STAGE & POLE AT 15 MHZ

```
R1 1 3 5E11
R2 2 3 5E11
R3 5 50 3871.3
R4 6 50 3871.3
CIN 1 2 5E-12
C2 5 6 1.37E-12
I1 99 4 0.1E-3
IOS 1 2 5E-13
EOS 7 1 POLY(1) 21 24 200E-6 1
J1 5 2 4 JX
J2 6 7 4 JX
```

EREF 98 0 24 0 1

\* GAIN STAGE & POLE AT 124 HZ

```
R5 9 98 1.16E8
C3 9 98 1.11E-11
G1 98 9 5 6 2.58E-4
V2 99 8 1.2
V3 10 50 1.2
D1 9 8 DX
D2 10 9 DX
```

\* NEGATIVE ZERO AT 4 MHZ

```
R6 11 12 1E6
R7 12 98 1
C4 11 12 39.8E-15
E2 11 98 9 24 1E6
```

\* POLE AT 15 MHZ

```
R8 13 98 1E6
C5 13 98 10.6E-15
G2 98 13 12 24 1E-6
```

\* POLE AT 15 MHZ

```
R9 14 98 1E6
C6 14 98 10.6E-15
G3 98 14 13 24 1E-6
```

\* POLE AT 15 MHZ

```
R19 19 98 1E6
C13 19 98 10.6E-15
G11 98 19 14 24 1E-6
```

\* COMMON-MODE GAIN NETWORK WITH ZERO AT 11 KHZ

```
R21 20 21 1E6
R22 21 98 1
C14 20 21 14.38E-12
E13 98 20 3 24 31.62
```

\* POLE AT 15 MHZ

```
R23 23 98 1E6
C15 23 98 10.6E-15
G15 98 23 19 24 1E-6
```

\* OUTPUT STAGE

```
R25 24 99 5E6
R26 24 50 5E6
ISY 99 50 107E-6
R27 29 99 700
R28 29 50 700
L5 29 30 1E-8
G17 27 50 23 29 1.43E-3
G18 28 50 29 23 1.43E-3
G19 29 99 99 23 1.43E-3
G20 50 29 23 50 1.43E-3
V4 25 29 2.8
V5 29 26 3.5
D3 23 25 DX
D4 26 23 DX
D5 99 27 DX
D6 99 28 DX
D7 50 27 DY
D8 50 28 DY
```

\* MODELS USED

```
.MODEL JX PJF(BETA = 3.34E-4
VTO = -2.000 IS = 3E-12)
.MODEL DX D(IS = 1E-15)
.MODEL DY D(IS = 1E-15 BV = 50)
.ENDS OP282
```

# OP282/OP482

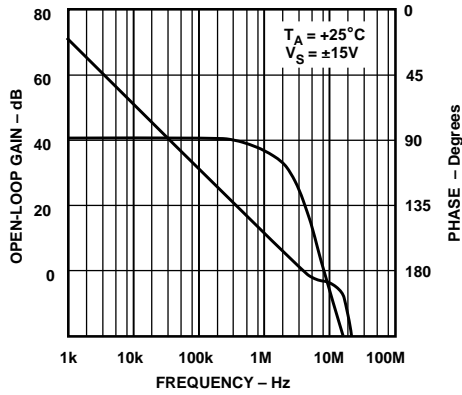

Figure 5. Open-Loop Gain, Phase vs. Frequency

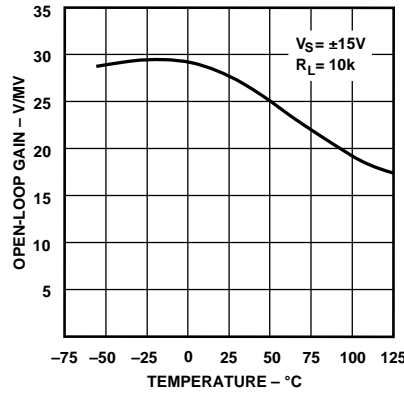

Figure 8. Open-Loop Gain (V/mV) vs. Temperature

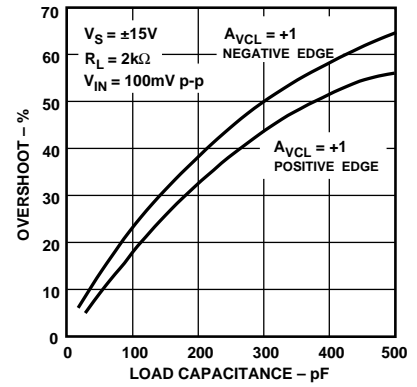

Figure 11. Small Signal Overshoot vs. Load Capacitance

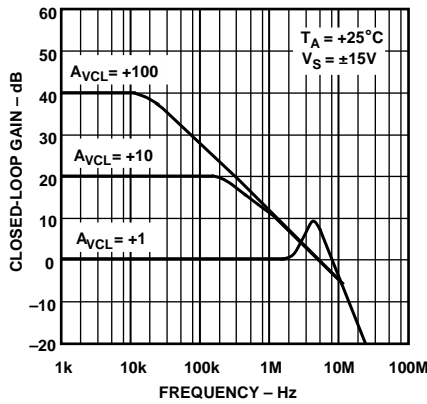

Figure 6. Closed-Loop Gain vs. Frequency

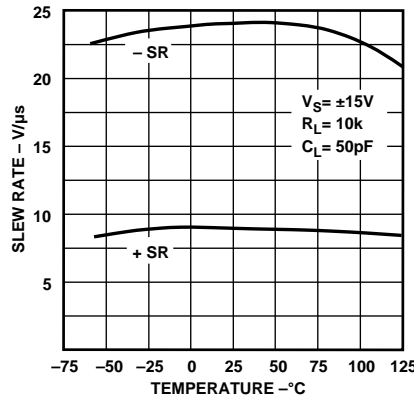

Figure 9. OP282/OP482 Slew Rate vs. Temperature

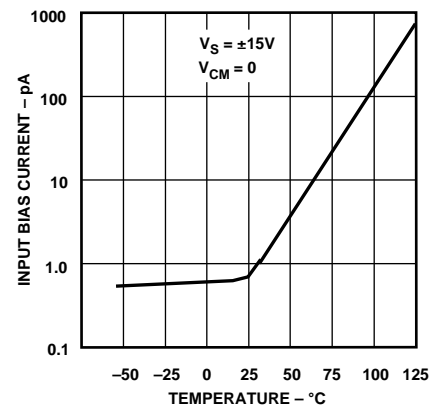

Figure 12. OP282 Input Bias Current vs. Temperature

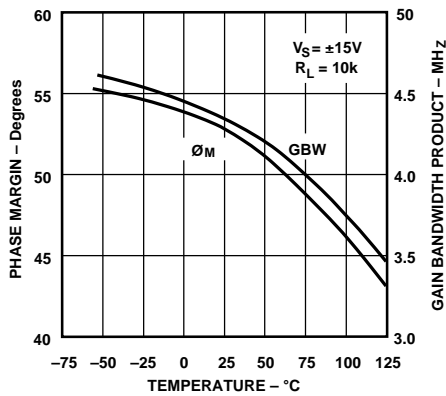

Figure 7. OP482 Phase Margin and Gain Bandwidth Product vs. Temperature

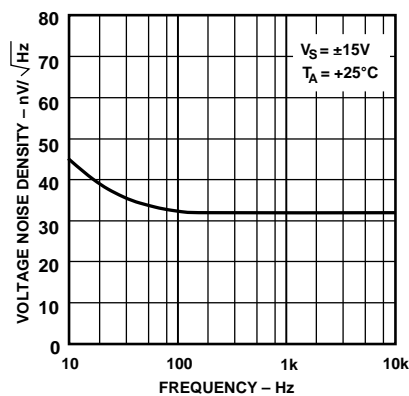

Figure 10. Voltage Noise Density vs. Frequency

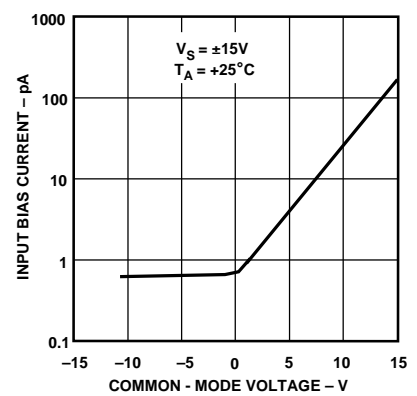

Figure 13. OP282 Input Bias Current vs. Common-Mode Voltage



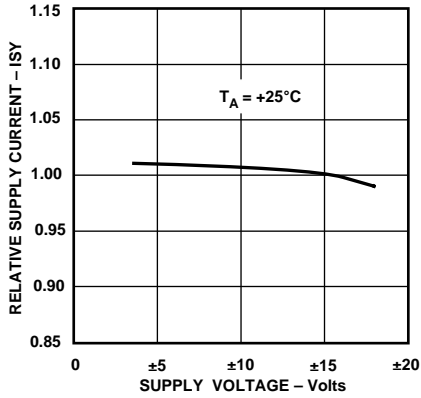

Figure 14. Relative Supply Current vs. Supply Voltage

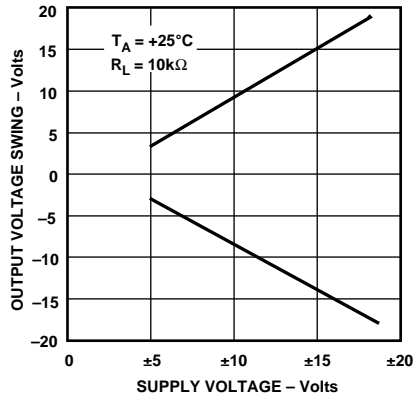

Figure 17. Output Voltage Swing vs. Supply Voltage

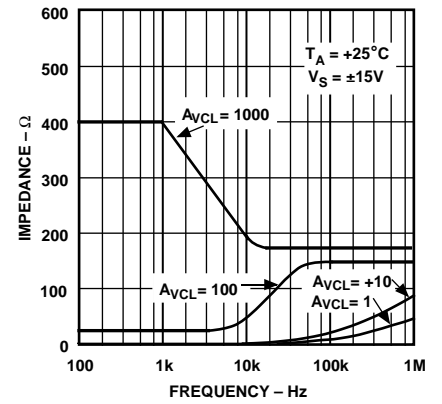

Figure 20. OP482 Closed-Loop Output Impedance vs. Frequency

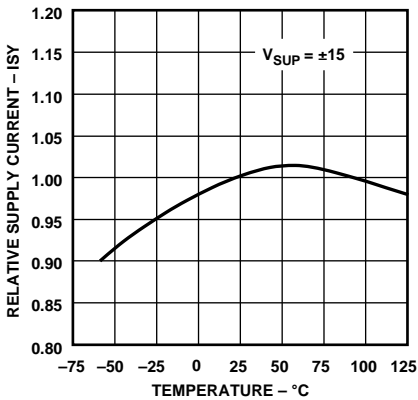

Figure 15. Relative Supply Current vs. Temperature

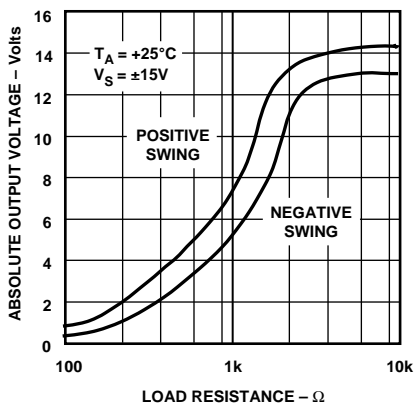

Figure 18. Maximum Output Voltage vs. Load Resistance

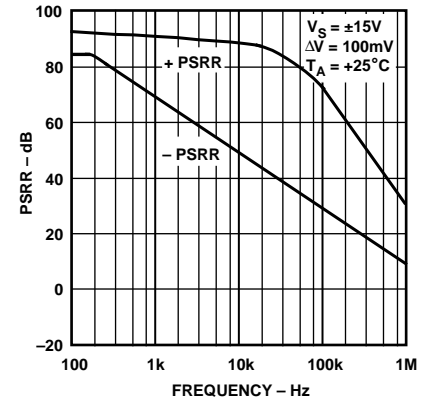

Figure 21. OP282 Power Supply Rejection Ratio (PSRR) vs. Frequency

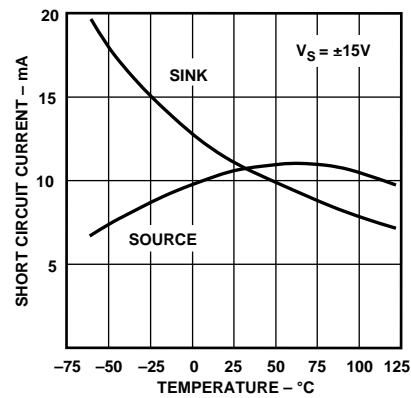

Figure 16. OP282/OP482 Short Circuit Current vs. Temperature

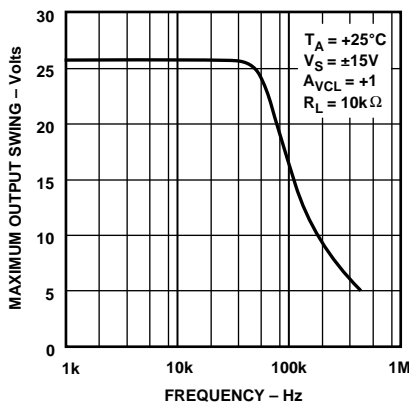

Figure 19. Maximum Output Swing vs. Frequency

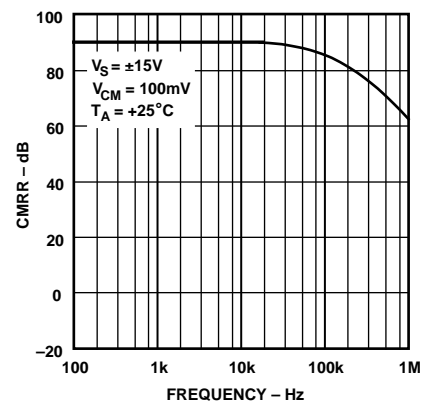

Figure 22. OP282 Common-Mode Rejection Ratio (CMRR) vs. Frequency

# OP282/OP482

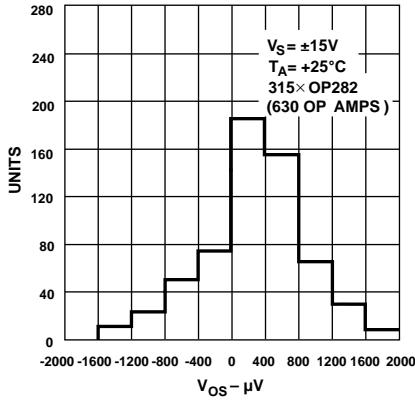

Figure 23.  $V_{OS}$  Distribution "P" Package

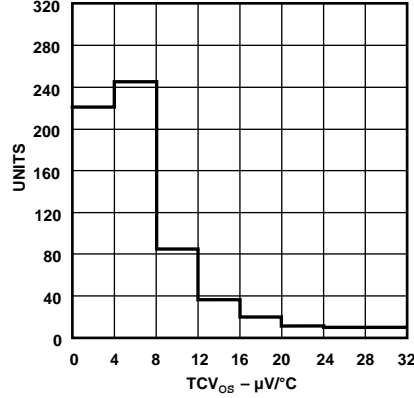

Figure 25. OP282  $TCV_{OS}$  ( $\mu V/^{\circ}C$ ) Distribution "P" Package

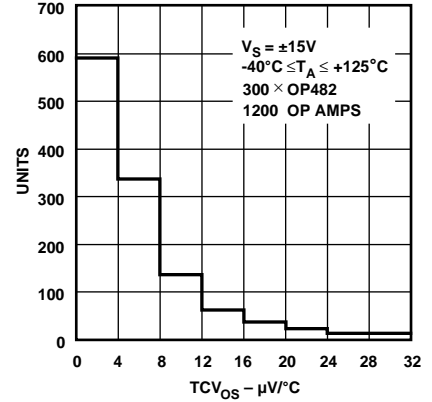

Figure 27. OP482  $TCV_{OS}$  Distribution "Z" Package

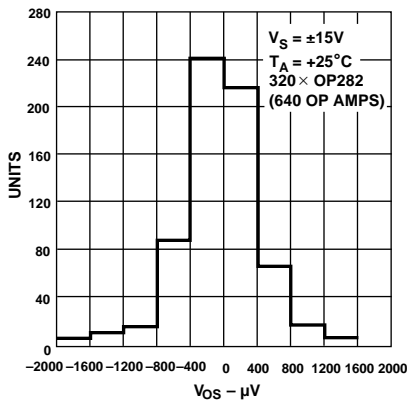

Figure 24.  $V_{OS}$  Distribution "Z" Package

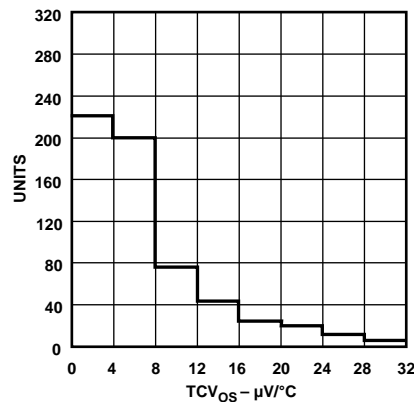

Figure 26. OP282  $TCV_{OS}$  ( $\mu V/^{\circ}C$ ) Distribution "Z" Package

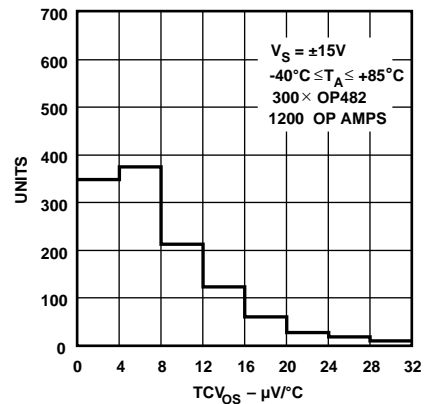

Figure 28.  $TCV_{OS}$  Distribution "P" Package

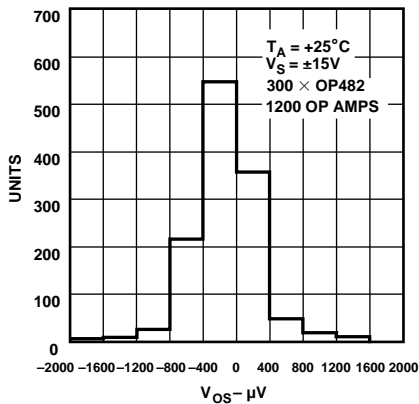

Figure 29. OP482  $V_{OS}$  Distribution "Z" Package

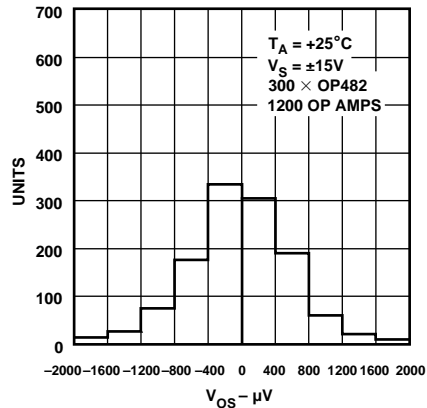
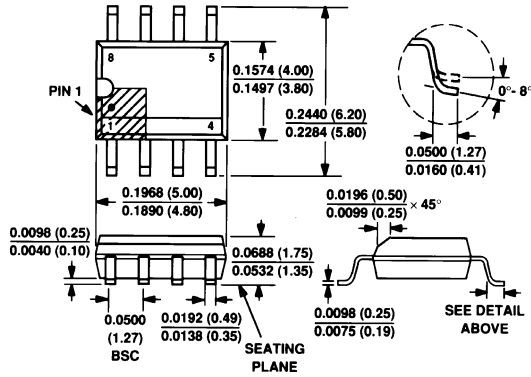

Figure 30. OP482  $V_{OS}$  Distribution "P" Package

**OUTLINE DIMENSIONS**

Dimensions shown in inches and (mm).

**8-Lead Narrow-Body SOIC  
(S Suffix)**



**8-Lead Epoxy DIP  
(P Suffix)**

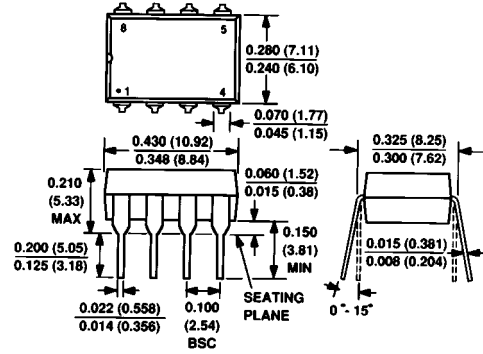

**14-Lead Narrow-Body SOIC  
(S Suffix)**

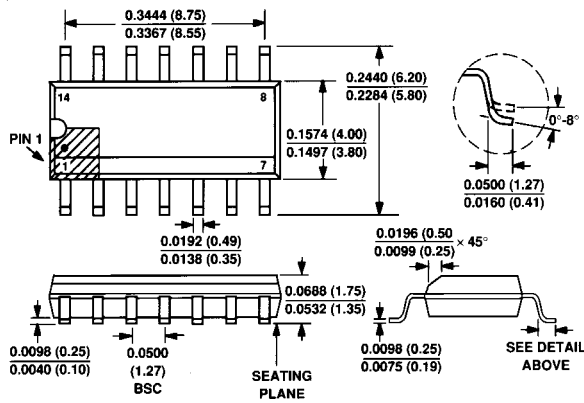

**14-Lead Epoxy DIP  
(P Suffix)**

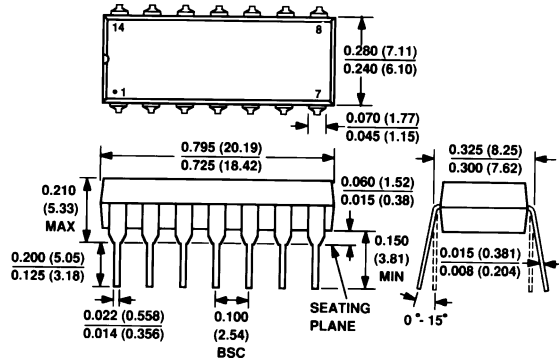

**20-Position Chip Carrier  
(RC Suffix)**

