

GENERAL DESCRIPTION

The AMD family of subscriber line interface circuit (SLIC) products provide the telephone interface functions required throughout the worldwide market. AMD SLIC devices address all major telephony markets including central office (CO), private branch exchange (PBX), digital loop carrier (DLC), fiber-in-the-loop (FITL), radio-in-the-loop (RITL), hybrid fiber coax (HFC), and video telephony applications.

The AMD SLIC devices offer support of BORSHT (battery feed, overvoltage protection, ringing, supervision, hybrid, and test) functions with features including current limiting, on-hook transmission, polarity reversal, tip-open, and loop-current detection. These features allow reduction of linecard cost by minimizing component count, conserving board space, and supporting automated manufacturing.

The AMD SLIC devices provide the two- to four-wire hybrid function, DC loop feed, and two-wire supervision. Two-wire termination is programmed by a scaled impedance network. Transhybrid balance can be achieved with an external balance circuit or simply programmed using a companion AMD codec device, the Am79C02/03/031 DSLAC™ device, the Am79Q02/021/031 Programmable Quad SLAC (QSLAC™) device, or the Am79Q5457/4457 Nonprogrammable QSLAC device.

The Am79R70 Ringing SLIC device is a bipolar monolithic SLIC that offers on-chip ringing. Now designers can achieve significant cost reductions at the system level for short-loop applications by integrating the ringing function on chip. Examples of such applications would be ISDN Terminal Adaptors and set top boxes. Using a CMOS-compatible input waveform and wave shaping R-C network, the Am79R70 Ringing SLIC can provide trapezoidal wave ringing to meet various design requirements.

In order to further enhance the suitability of this device in short-loop, distributed switching applications, AMD has maximized power savings by incorporating battery switching on chip. The Am79R70 Ringing SLIC device switches between two battery supplies such that in the Off-hook (active) state, a low battery is used to save power. In order to meet the Open Circuit voltage requirements of fax machines and maintenance termination units (MTU), the SLIC automatically switches to a higher voltage in the On-hook (standby) state.

Like all of the AMD SLIC devices, the Am79R70 Ringing SLIC device supports on-hook transmission, ring-trip detection and programmable loop-detect threshold. The Am79R70 Ringing SLIC device is a programmable constant-current feed device with two on-chip relay drivers to operate external relays. This unique device is available in the proven AMD 75 V bipolar process in 32-pin PLCC packages.

ORDERING INFORMATION

Standard Products

AMD standard products are available in several packages and operating ranges. The order number (Valid Combination) is formed by a combination of the elements below

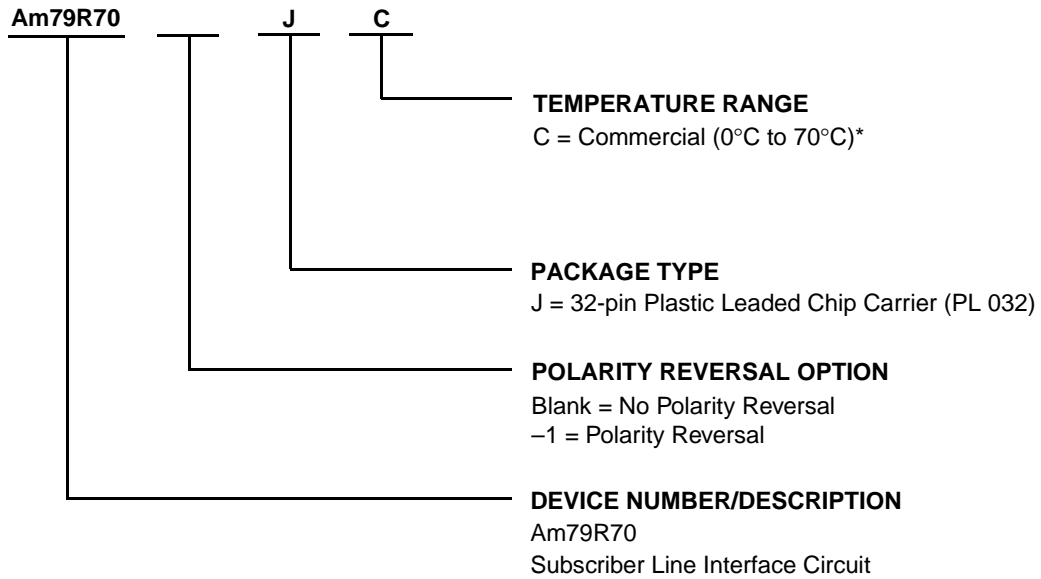

Valid Combinations		
Am79R70		JC
	-1	

Valid Combinations

Valid Combinations list configurations planned to be supported in volume for this device. Consult the local AMD sales office to confirm availability of specific valid combinations, to check on newly released combinations, and to obtain additional data on AMD's standard military grade products.

Note:

* Functionality of the device from 0°C to +70°C is guaranteed by production testing.

CONNECTION DIAGRAM

Top View

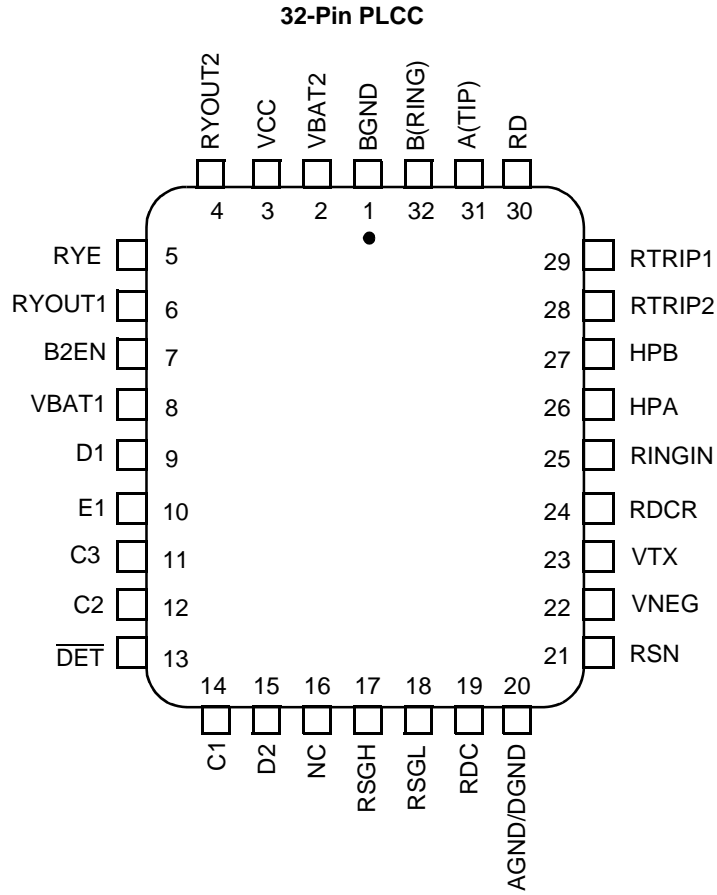

Notes:

1. Pin 1 is marked for orientation.
2. NC = No connect

PIN DESCRIPTIONS

Pin Names	Type	Description
AGND/DGND	Gnd	Analog and Digital ground are connected internally to a single pin.
A(TIP)	Output	Output of A(TIP) power amplifier.
B2EN	Input	VBAT2 Enable. Logic Low enables operation from V _{BAT2} . Logic High enables operation from V _{BAT1} . TTL compatible.
BGND	Gnd	Battery (power) ground.
B(RING)	Output	Output of B(RING) power amplifier.
C3–C1	Inputs	Decoder. TTL compatible. C3 is MSB and C1 is LSB.
D1	Input	Relay1 Control. TTL compatible. Logic Low activates the Relay1 relay driver.
D2	Input	(Option) Relay2 Control. TTL compatible. Logic Low activates the Relay2 relay driver.
$\overline{\text{DET}}$	Output	Detector. Logic Low indicates that the selected detector is tripped. Logic inputs C3–C1, E1, and E0 select the detector. Open-collector with a built-in 15 k Ω pull-up resistor.
E1	Input	(Option) A logic High selects the off-hook detector. A logic Low selects the ground-key detector. TTL compatible.
HPA	Capacitor	High-pass filter capacitor; A(TIP) side of high-pass filter capacitor.
HPB	Capacitor	High-pass filter capacitor; B(RING) side of high-pass filter capacitor.
RD	Resistor	Detector resistor. Threshold modification/filter point for the off-hook detector.
RDC	Resistor	DC feed resistor. Connection point for the DC feed current programming network, which also connects to the receiver summing node (RSN). V _{RDC} is negative for normal polarity and positive for reverse polarity.
RDCR	—	Connection point for feedback during ringing.
RINGIN	Input	Ring Signal Input. Pin for ring signal input. Square-wave shaped by external RC filter. Requires 50% duty cycle. CMOS-compatible input.
RSGH	Input	Saturation Guard High. Pin for resistor to adjust Open Circuit voltage when operating from V _{BAT1} .
RSGL	Input	Saturation Guard Low. Pin for resistor to adjust the anti-saturation cut-in voltage when operating from both V _{BAT1} and V _{BAT2} .
RSN	Input	The metallic current (AC and DC) between A(TIP) and B(RING) is equal to 1000 x the current into this pin. The networks that program receive gain, two-wire impedance, and feed current all connect to this node.
RTRIP1	Input	Ring-trip detector. Ring-trip detector threshold set and filter pin.
RTRIP2	Input	Ring-trip detector threshold offset (switch to V _{BAT1}). For power conservation in any nonringing state, this switch is open.
RYE	Output	Common Emitter of RYOUT1/RYOUT2. Emitter output of RYOUT1 and RYOUT2. Normally connected to relay ground.
RYOUT1	Output	Relay/switch driver. Open collector driver with emitter internally connected to RYE.
RYOUT2	Output	(Option) Relay/switch driver. Open collector driver emitter internally connected to RYE.
VBAT1	Battery	Battery supply and connection to substrate.
VBAT2	Battery	Power supply to output amplifiers. Connect to off-hook battery through a diode.
VCC	Power	Positive analog power supply.
VNEG	Power	Negative analog power supply. This pin is the return for the intern VEE regulator.
VREG	Input	Regulated Voltage. Provides negative power supply for power amplifiers, connection point for inductor, filter capacitor, and chopper stabilization.
VTX	Output	Transmit Audio. This output is 0.5066 times the A(TIP) and B(RING) metallic voltage. VTX also sources the two-wire input impedance programming network.

ABSOLUTE MAXIMUM RATINGS

Storage temperature	-55°C to +150°C
V _{CC} with respect to AGND/DGND	0.4 V to +7 V
V _{NEG} with respect to AGND/DGND	0.4 V to V _{BAT2}
V _{BAT2}	V _{BAT1} to GND
V _{BAT1} with respect to AGND/DGND:	
Continuous	+0.4 V to -80 V
10 ms	+0.4 V to -85 V
BGND with respect to AGND/DGND.....	+3 V to -3 V
A(TIP) or B(RING) to BGND:	
Continuous	V _{BAT1} -5 V to +1 V
10 ms (f = 0.1 Hz)	V _{BAT1} -10 V to +5 V
1 μs (f = 0.1 Hz)	V _{BAT1} -15 V to +8 V
250 ns (f = 0.1 Hz)	V _{BAT1} -20 V to +12 V
Current from A(TIP) or B(RING).....	±150 mA
RYOUT1, RYOUT2 current.....	75 mA
RYOUT1, RYOUT2 voltage	RYE to +7 V
RYOUT1, RYOUT2 transient	RYE to +10 V
RYE voltage	BGND to V _{BAT1}
C3-C1, D2-D1, E1, B2EN, and RINGIN	
Input voltage	-0.4 V to V _{CC} + 0.4 V
Maximum power dissipation, continuous,	
T _A = 70°C, No heat sink (See note):	
In 32-pin PLCC package.....	1.67 W
Thermal Data:.....	θ _{JA}
In 32-pin PLCC package.....	45°C/W typ

Note: Thermal limiting circuitry on chip will shut down the circuit at a junction temperature of about 165°C. The device should never see this temperature and operation above 145°C junction temperature may degrade device reliability. See the SLIC Packaging Considerations for more information.

Stresses above those listed under Absolute Maximum Ratings may cause permanent device failure. Functionality at or above these limits is not implied. Exposure to Absolute Maximum Ratings for extended periods may affect device reliability.

OPERATING RANGES**Commercial (C) Devices**

Ambient temperature	0°C to +70°C*
V _{CC}	4.75 V to 5.25 V
V _{NEG}	-4.75 V to V _{BAT2}
V _{BAT1}	-40 V to -67 V
V _{BAT2}	-19 V to V _{BAT1}
AGND/DGND.....	0 V
BGND with respect to	
AGND/DGND	-100 mV to +100 mV
Load resistance on VTX to ground.....	20 kΩ min

The Operating Ranges define those limits between which the functionality of the device is guaranteed.

** Functionality of the device from 0°C to +70°C is guaranteed by production testing.*

ELECTRICAL CHARACTERISTICS

Description	Test Conditions (See Note 1)	Min	Typ	Max	Unit	Note
Transmission Performance						
2-wire return loss	200 Hz to 3.4 kHz (Test Circuit D)	26			dB	1, 4, 6
Z_{VTX} , analog output impedance			3	20	Ω	4
V_{VTX} , analog output offset voltage		-50		+50	mV	
Z_{RSN} , analog input impedance			1	20	Ω	4
Overload level, 2-wire and 4-wire, off hook	Active state	2.5			Vpk	2a
Overload level, 2-wire	On hook, $R_{LAC} = 600 \Omega$	0.88			Vrms	2b
THD (Total Harmonic Distortion)	+3 dBm, BAT2 = -24 V		-64	-50	dB	5
THD, on hook, OHT state	0 dBm, $R_{LAC} = 600 \Omega$, BAT1 = -67 V			-40		
Longitudinal Performance (See Test Circuit C)						
Longitudinal to metallic L-T, L-4 balance	200 Hz to 3.4 kHz	40			dB	
Longitudinal signal generation 4-L	200 Hz to 800 Hz, Normal polarity	40				
Longitudinal current per pin (A or B)	Active or OHT state	12	28		mArms	4
Longitudinal impedance at A or B	0 to 100 Hz, $T_A = +25^\circ\text{C}$		25		Ω/pin	
Idle Channel Noise						
C-message weighted noise			+7	+14	dBrnC	
Psophometric weighted noise			-83	-76	dBmp	4
Insertion Loss and Four- to Four-Wire Balance Return Signal (See Test Circuits A and B)						
Gain accuracy 4- to 2-wire	0 dBm, 1 kHz	-0.20	0	+0.20	dB	3
Gain accuracy 2- to 4-wire and 4- to 4-wire	0 dBm, 1 kHz	-6.22	-6.02	-5.82		
Gain accuracy 4- to 2-wire	OHT state, on hook	-0.35	0	+0.35		
Gain accuracy 2- to 4-wire and 4- to 4-wire	OHT state, on hook	-6.37	-6.02	-5.77		
Gain accuracy over frequency	300 to 3400 Hz relative to 1 kHz	-0.10		+0.10		
Gain tracking	+3 dBm to -55 dBm relative to 0 dBm	-0.10		+0.10		3, 4
Gain tracking OHT state, on hook	0 dBm to -37 dBm +3 dBm to 0 dBm	-0.10 -0.35		+0.10 +0.35		3, 4 3
Group delay	0 dBm, 1 kHz		3		μs	1, 4, 6

ELECTRICAL CHARACTERISTICS (CONTINUED)

Description	Test Conditions (See Note 1)	Min	Typ	Max	Unit	Note
Line Characteristics						
I _L , Loop-current accuracy	I _L in constant-current region, B2EN = 0	0.9I _L	I _L	1.1I _L	mA	
I _L , Long loops, Active state	R _{LDC} = 600 Ω, RSGL = open R _{LDC} = 750 Ω, RSGL = short	20 20	21.7			
I _L , Accuracy, Standby state	$I_L = \frac{ V_{BAT1} - 10 \text{ V}}{R_L + 400}$	0.8I _L	I _L	1.2I _L		
	I _L = constant-current region T _A = 25°C	18	27	39		
I _L LIM	Active, A and B to ground OHT, A and B to ground		55 55	110		4
I _L , Loop current, Open Circuit state	R _L = 0			100	μA	
I _A , Pin A leakage, Tip Open state	R _L = 0			100		
I _B , Pin B current, Tip Open state	B to ground		34		mA	
V _A , Standby, ground-start signaling	A to -48 V = 7 kΩ, B to ground = 100 Ω	-7.5	-5		V	4
V _{AB} , Open Circuit voltage		42				7
Power Supply Rejection Ratio (V_{RIPPLE} = 100 mVrms), Active Normal State						
V _{CC}	50 Hz to 3400 Hz	33	50		dB	5
V _{NEG}	50 Hz to 3400 Hz	30	40			
V _{BAT1}	50 Hz to 3400 Hz	30	50			
V _{BAT2}	50 Hz to 3400 Hz	30	50			
Power Dissipation						
On hook, Open Circuit state	V _{BAT1}		48	100	mW	
On hook, Standby state	V _{BAT2}		55	80		9
On hook, OHT state	V _{BAT1}		200	300		
On hook, Active state	V _{BAT1}		220	350		
Off hook, Standby state	V _{BAT1} or V _{BAT2} R _L = 300 Ω		2000	2800		9
Off hook, OHT state	V _{BAT1} R _L = 300 Ω		2000	2200		
Off hook, Active state	V _{BAT2} R _L = 300 Ω		550	750		
Supply Currents						
I _{CC} , On-hook V _{CC} supply current	Open Circuit state		3.0	4.5	mA	
	Standby state		3.2	5.5		
	OHT state		6.2	8.0		
	Active state–normal		6.5	9.0		
I _{NEG} , On-hook V _{NEG} supply current	Open Circuit state		0.1	0.2		
	Standby state		0.1	0.2		
	OHT state		0.7	1.1		
	Active state–normal		0.7	1.1		
I _{BAT} , On-hook V _{BAT} supply current	Open Circuit state		0.45	1.0		
	Standby state		0.6	1.5		
	OHT state		2.0	4.0		
	Active state–normal		2.7	5.0		

ELECTRICAL CHARACTERISTICS (continued)

Description	Test Conditions (See Note 1)	Min	Typ	Max	Unit	Note
Logic Inputs (C3–C1, D2–D1, E1, and B2EN)						
V _{IH} , Input High voltage		2.0			V	
V _{IL} , Input Low voltage				0.8		
I _{IH} , Input High current		–75		40	μA	
I _{IL} , Input Low current		–400				
Logic Output DET						
V _{OL} , Output Low voltage	I _{OUT} = 0.8 mA, 15 kΩ to V _{CC}			0.40	V	
V _{OH} , Output High voltage	I _{OUT} = –0.1 mA, 15 kΩ to V _{CC}	2.4				
Ring-Trip Detector Input						
Ring detect accuracy	$IRTD = \left(\frac{ BAT1 - 1}{RRT1} + 24 \mu A \right) \cdot 335$	–10		+10	%	
Ring Signal						
V _{AB} , Ringing	Bat1 = –67 V, ringload = 1570 Ω	57	61		Vpk	
V _{AB} Ringing offset	V _{RINGIN} = 2.5 V		0		V	
ΔV _{AB} /ΔV _{RINGIN} (RINGIN gain)			180		—	
Ground-Key Detector Thresholds						
Ground-key resistive threshold	B to ground	2	5	10	kΩ	
Ground-key current threshold	B to ground		11		mA	
Loop Detector						
R _{LTH} , Loop-resistance detect threshold	Active, V _{BAT1} Active, V _{BAT2} Standby	–20 –20 –12		20 20 12	%	8
Relay Driver Output (RELAY1 and 2)						
V _{OL} , On voltage (each output)	I _{OL} = 30 mA		+0.25	+0.4	V	4
V _{OL} , On voltage (each output)	I _{OL} = 40 mA		+0.30	+0.8		
I _{OH} , Off leakage (each output)	V _{OH} = +5 V			100	μA	
Zener breakover (each output)	I _Z = 100 μA	6.6	7.9		V	
Zener on voltage (each output)	I _Z = 30 mA		11			

RELAY DRIVER SCHEMATIC

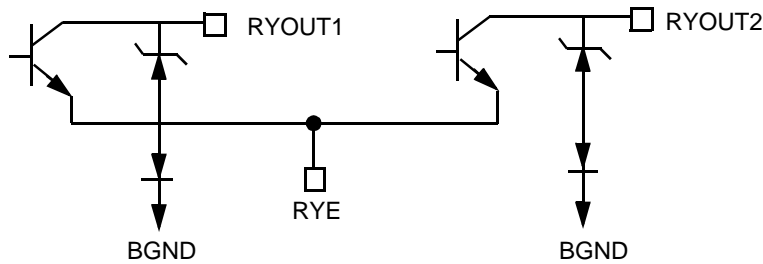

Notes:

- Unless otherwise noted, test conditions are $BAT1 = -67\text{ V}$, $BAT2 = -24\text{ V}$, $V_{CC} = +5\text{ V}$, $V_{NEG} = -5\text{ V}$, $R_L = 600\ \Omega$, $R_{DC1} = 80\text{ k}\Omega$, $R_{DC2} = 20\text{ k}\Omega$, $R_D = 75\text{ k}\Omega$, no fuse resistors, $C_{HP} = 0.018\ \mu\text{F}$, $C_{DC} = 1.2\ \mu\text{F}$, $D_1 = D_2 = 1\text{N}400\text{x}$, two-wire AC input impedance (ZSL) is a $600\ \Omega$ resistance synthesized by the programming network shown below. $R_{SGL} = \text{open}$, $R_{SGH} = \text{open}$, $R_{DCR} = 2\text{ k}\Omega$, $R_{RT1} = 430\text{ k}\Omega$, $R_{RT2} = 12\text{ k}\Omega$, $C_{RT} = 1.5\ \mu\text{F}$, $R_{SLEW} = 150\text{ k}\Omega$, $C_{SLEW} = 0.33\ \mu\text{F}$.

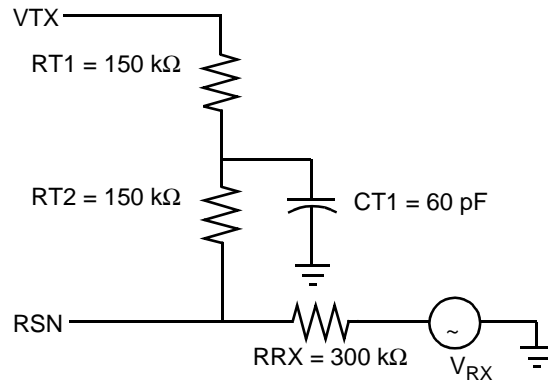

- Overload level is defined when $THD = 1\%$.
 - Overload level is defined when $THD = 1.5\%$.
- Balance return signal is the signal generated at V_{TX} by V_{RX} . This specification assumes that the two-wire AC load impedance matches the programmed impedance.
- Not tested in production. This parameter is guaranteed by characterization or correlation to other tests.
- This parameter is tested at 1 kHz in production. Performance at other frequencies is guaranteed by characterization.
- Group delay can be greatly reduced by using a Z_T network such as that shown in Note 1 above. The network reduces the group delay to less than $2\ \mu\text{s}$ and increases 2WRL. The effect of group delay on linecard performance may also be compensated for by synthesizing complex impedance with the QSLAC or DSLAC device.
- Open Circuit V_{AB} can be modified using RSGH.
- R_D must be greater than $56\text{ k}\Omega$. Refer to Table 2 for typical value of R_{LTH} .
- Lower power is achieved by switching into low-battery state in standby. Standby loop current is returned to V_{BAT1} regardless of the battery selected.

Table 1. SLIC Decoding

State	C3 C2 C1	2-Wire Status	(DET) Output		Battery Selection
			E1 = 1	E1 = 0	
0	0 0 0	Open Circuit	Ring trip	Ring trip	B2EN
1	0 0 1	Ringing	Ring trip	Ring trip	
2	0 1 0	Active	Loop detector	Ground key	
3	0 1 1	On-hook TX (OHT)	Loop detector	Ground key	
4	1 0 0	Tip Open	Loop detector	Ground key	B2EN = 1**
5	1 0 1	Standby	Loop detector	Ground key	V_{BAT1}
6*	1 1 0	Active Polarity Reversal	Loop detector	Ground key	B2EN
7*	1 1 1	OHT Polarity Reversal	Loop detector	Ground key	

Notes:

- * Only -1 performance grade devices support polarity reversal.
- ** For correct ground-start operation using Tip Open, V_{BAT1} on-hook battery must be used.

Table 2. User-Programmable Components

$Z_T = 500(Z_{2WIN} - 2R_F)$	<p>Z_T is connected between the VTX and RSN pins. The fuse resistors are R_F, and Z_{2WIN} is the desired 2-wire AC input impedance. When computing Z_T, the internal current amplifier pole and any external stray capacitance between VTX and RSN must be taken into account.</p>
$Z_{RX} = \frac{Z_L}{G_{42L}} \cdot \frac{1000 \cdot Z_T}{Z_T + 500(Z_L + 2R_F)}$	<p>Z_{RX} is connected from V_{RX} to R_{SN}. Z_T is defined above, and G_{42L} is the desired receive gain.</p>
$R_{DC1} + R_{DC2} = \frac{2500}{I_{LOOP}}$ $R_{DCR1} + R_{DCR2} = \frac{3000}{I_{ringlim}}$ $C_{DC} = 19 \text{ ms} \cdot \frac{R_{DC1} + R_{DC2}}{R_{DC1}R_{DC2}}$ $C_{DCR} = \frac{R_{DCR1} + R_{DCR2}}{R_{DCR1}R_{DCR2}} \cdot 150 \mu\text{s}$	<p>R_{DC1}, R_{DC2}, and C_{DC} form the network connected to the RDC pin. I_{LOOP} is the desired loop current in the constant-current region.</p> <p>R_{DCR1}, R_{DCR2}, and C_{DCR} form the network connected to the RDCR pin. See Applications Circuit for these components.</p> <p>C_{DCR} sets the ringing time constant, which can be between 15 μs and 150 μs.</p>
$R_D = R_{LTH} \cdot 12.67 \text{ for high battery state}$	<p>R_D is the resistor connected from the RD pin to GND and R_{LTH} is the loop-resistance threshold between on-hook and off-hook detection. R_D should be greater than 56 kΩ to guarantee detection will occur in the Standby state. Choose the value of R_D for high battery state; then use the equation for R_{LTH} to find where the threshold is for low battery.</p>
<p>Loop-Threshold Detect Equations</p>	
$R_{LTH} = \frac{R_D}{12.67} \text{ for high battery}$	<p>This is the same equation as for R_D in the preceding equation, except solved for R_{LTH}.</p>
$R_{LTH} = \frac{R_D}{11.37} \text{ for low battery}$	<p>For low battery, the detect threshold is slightly higher, which will avoid oscillating between states.</p>
$R_{LTH} = \frac{ V_{BAT1} - 10}{915} \cdot R_D - 400 - 2R_F$	<p>$R_{LTH \text{ standby}} < R_{LTH \text{ active}} < V_{BAT1} < R_{LTH \text{ active}} < V_{BAT2}$, which will guarantee no unstable states under all operating conditions. This equation will show at what resistance the standby threshold will be; it is actually a current threshold rather than a resistance threshold, which is shown by the Vbat dependency.</p>

DC FEED CHARACTERISTICS

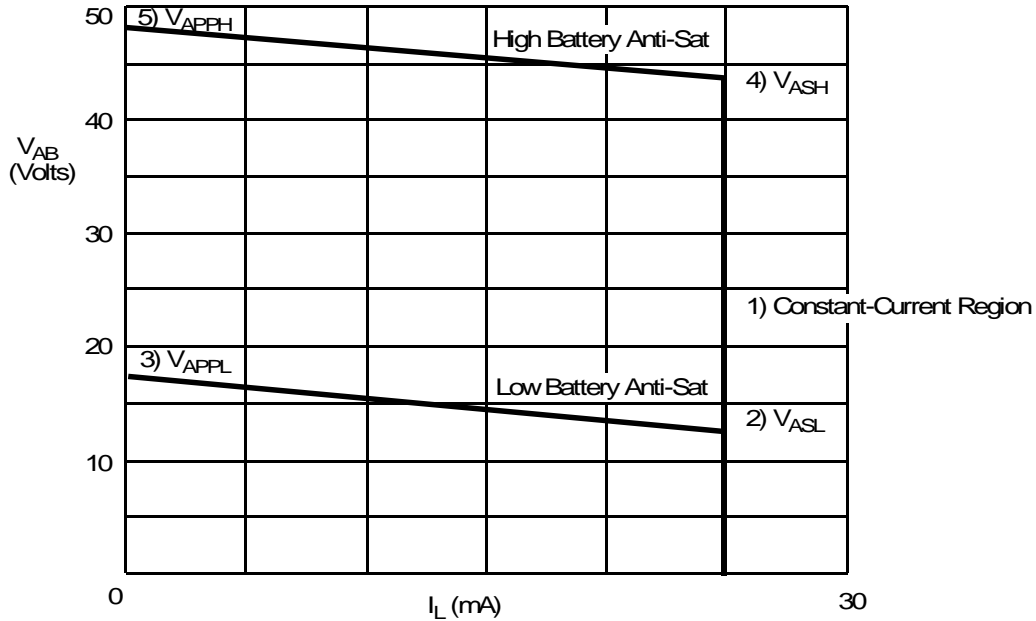

Figure 1. Typical V_{AB} vs. I_L DC Feed Characteristics

$$R_{DC} = R_{DC1} + R_{DC2} = 20 \text{ k}\Omega + 80 \text{ k}\Omega = 100 \text{ k}\Omega$$

$$(V_{BAT1} = -67 \text{ V}, V_{BAT2} = -24 \text{ V})$$

Notes:

1. Constant-current region: $V_{AB} = I_L R_L = \frac{2500}{R_{DC}} R_L$; where $R_L = R_L + 2R_F$

2. Low battery $V_{ASL} = \frac{1000 \cdot (104 \cdot 10^3 + R_{SGL})}{6720 \cdot 10^3 + (80 \cdot R_{SGL})}$; where R_{SGL} = resistor to GND, B2EN = logic Low.

Anti-sat region: $V_{ASL} = \frac{1000 \cdot (R_{SGL} - 56 \cdot 10^3)}{6720 \cdot 10^3 + (80 \cdot R_{SGL})}$; where R_{SGL} = resistor to V_{CC} , B2EN = logic Low.

R_{SGL} to V_{CC} must be greater than 100 k Ω .

3. $V_{APPL} = 4.17 + V_{ASL}$

$$I_{LOOPL} = \frac{V_{APPL}}{\frac{(R_{DC1} + R_{DC2})}{600} + 2R_F + R_{LOOP}}$$

4. High battery $V_{ASH} = V_{ASHH} + V_{ASL}$

Anti-sat region: $V_{ASHH} = \frac{1000 \cdot (70 \cdot 10^3 + R_{SGH})}{1934 \cdot 10^3 + (31.75 \cdot R_{SGH})}$; where R_{SGH} = resistor to GND, B2EN = logic High.

$$V_{ASHH} = \frac{1000 \cdot (R_{SGH} + 2.75 \cdot 10^3)}{1934 \cdot 10^3 + (31.75 \cdot R_{SGH})}$$
; where R_{SGH} = resistor to V_{CC} , B2EN = logic High.

R_{SGH} to V_{CC} must be greater than 100 k Ω .

5. $V_{APPH} = 4.17 + V_{ASH}$

$$I_{LOOPL} = \frac{V_{APPH}}{\frac{(R_{DC1} + R_{DC2})}{600} + 2R_F + R_{LOOP}}$$

RING-TRIP COMPONENTS

$$R_{RT2} = 12 \text{ k}\Omega$$

$$C_{RT} = 1.5 \text{ }\mu\text{F}$$

$$R_{RT1} = 300 \cdot CF \cdot \frac{V_{BAT1}}{V_{bat} - 3.5 - (15 \text{ }\mu\text{A} \cdot 300 \cdot CF \cdot (R_{LRT} + 150 + 2R_F))} \cdot (R_{LRT} + 150 + 2R_F)$$

where R_{LRT} = Loop-detection threshold resistance for ring trip and CF = Crest factor of ringing signal (≈ 1.25)

R_{SLEW} , C_{SLEW}

Ring waveform rise time $\approx 0.214 \cdot (R_{SLEW} \cdot C_{SLEW}) \approx tr$.

For a 1.25 crest factor @ 20 Hz, $tr \approx 10 \text{ mS}$.

$\therefore (R_{SLEW} = 150 \text{ k}\Omega, C_{SLEW} = 0.33 \text{ }\mu\text{F})$

C_{SLEW} should be changed if a different crest factor is desired.

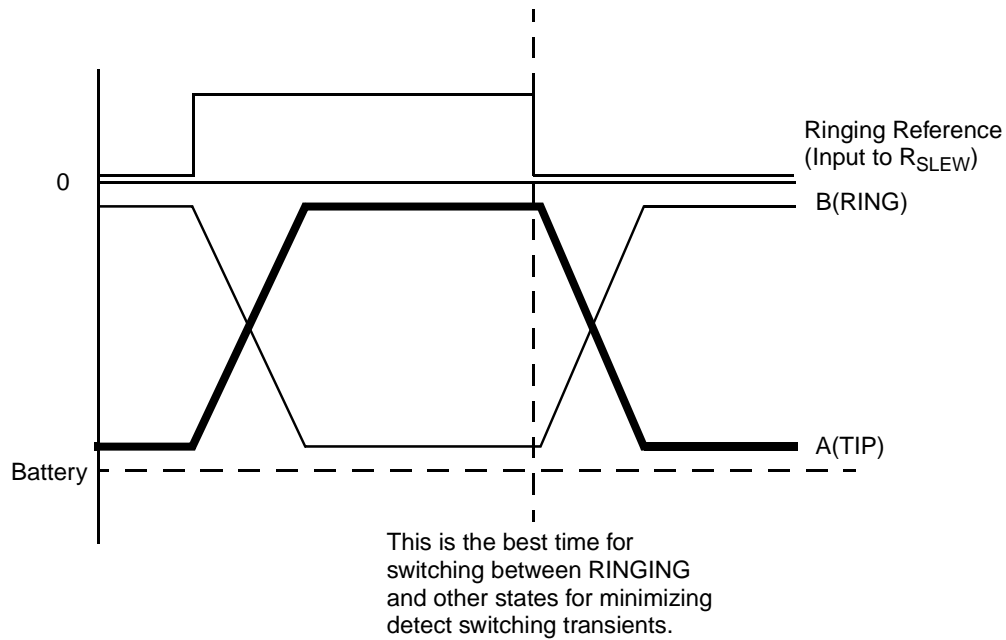
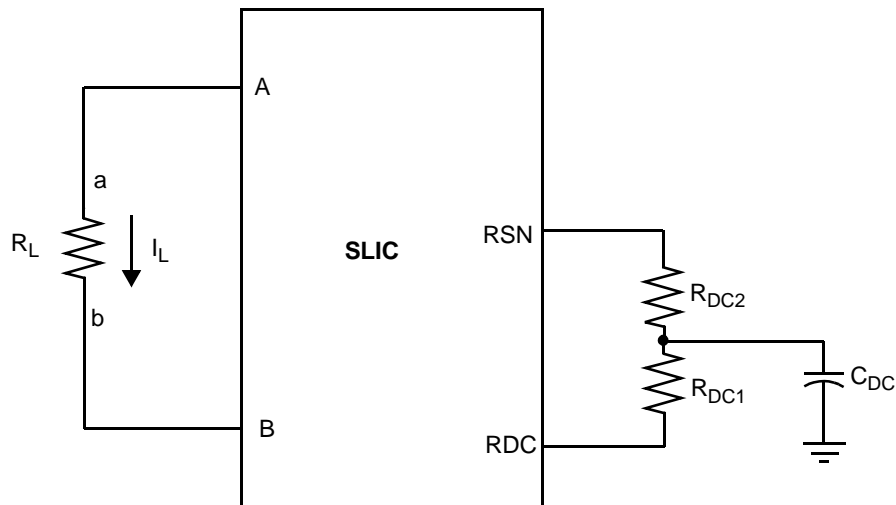

Figure 2. Ringing Waveforms



Feed current programmed by R_{DC1} and R_{DC2}

Figure 3. Feed Programming

TEST CIRCUITS

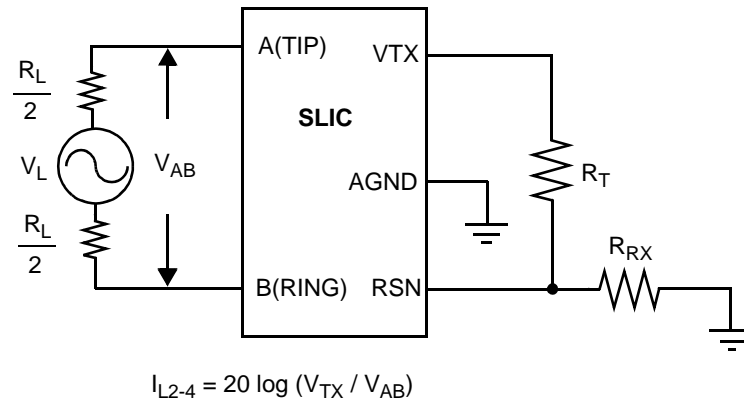

A. Two- to Four-Wire Insertion Loss

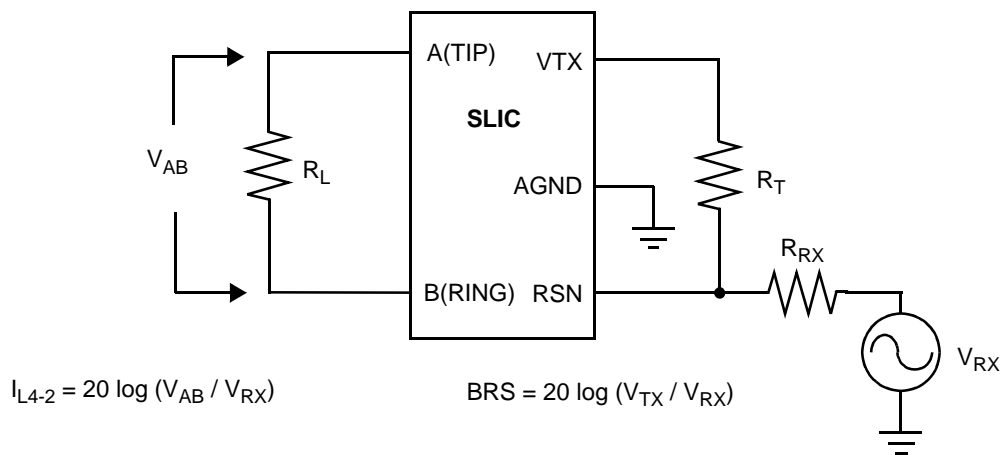

B. Four- to Two-Wire Insertion Loss and Four- to Four-Wire Balance Return Signal

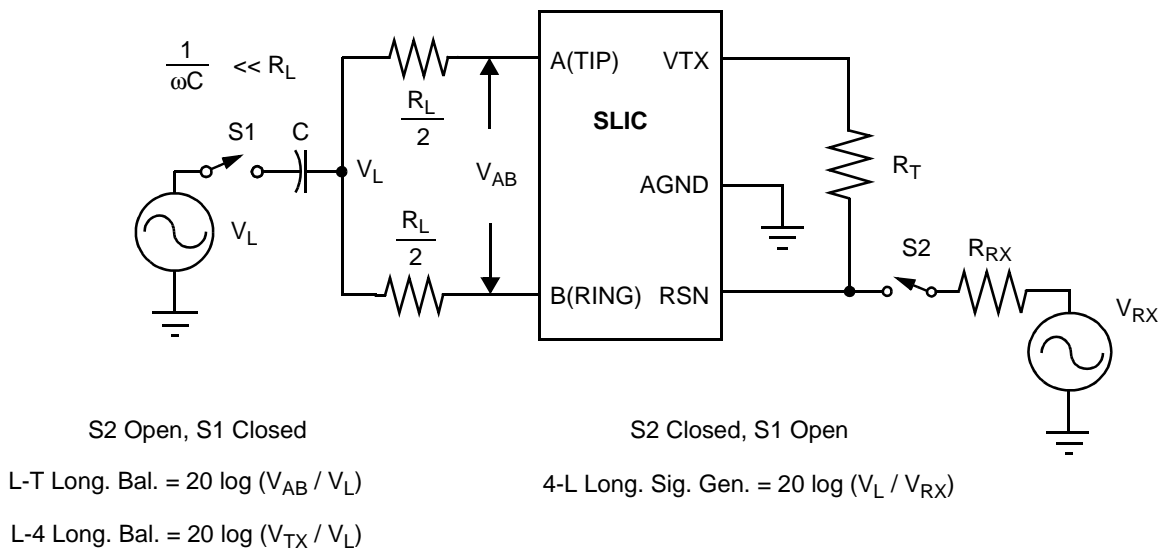

C. Longitudinal Balance

TEST CIRCUITS (continued)

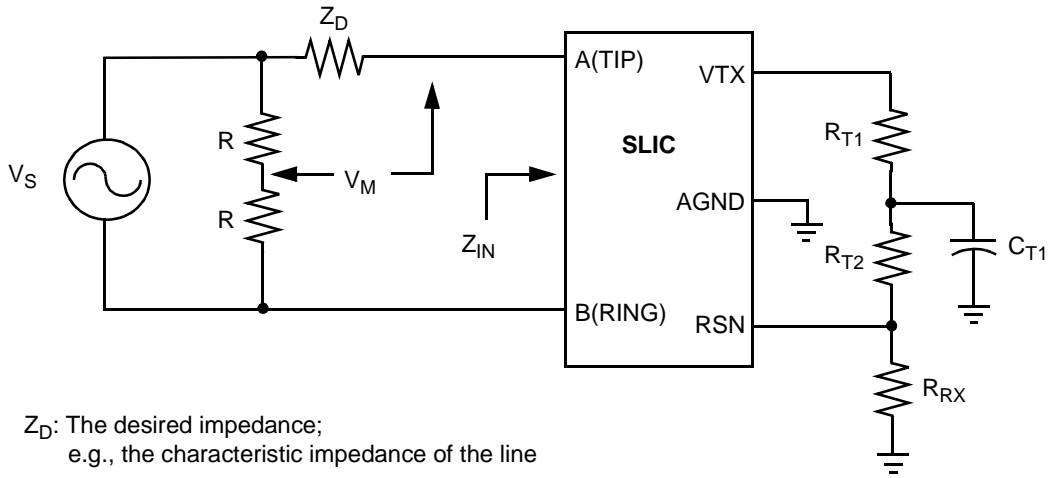

Z_D : The desired impedance;
e.g., the characteristic impedance of the line

$$\text{Return loss} = -20 \log (2 V_M / V_S)$$

D. Two-Wire Return Loss Test Circuit

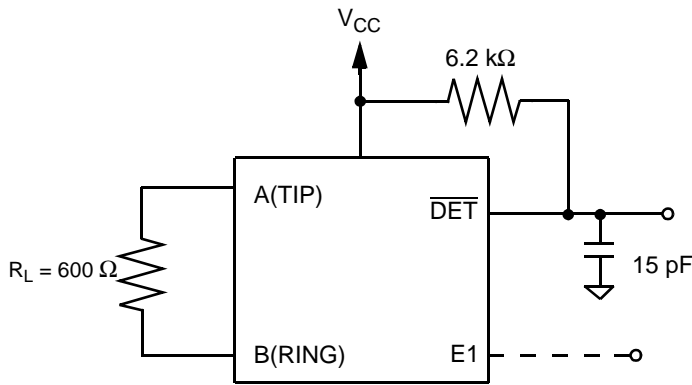

E. Loop-Detector Switching

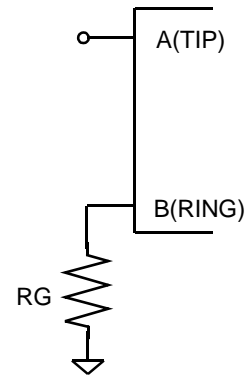

F. Ground-Key Switching

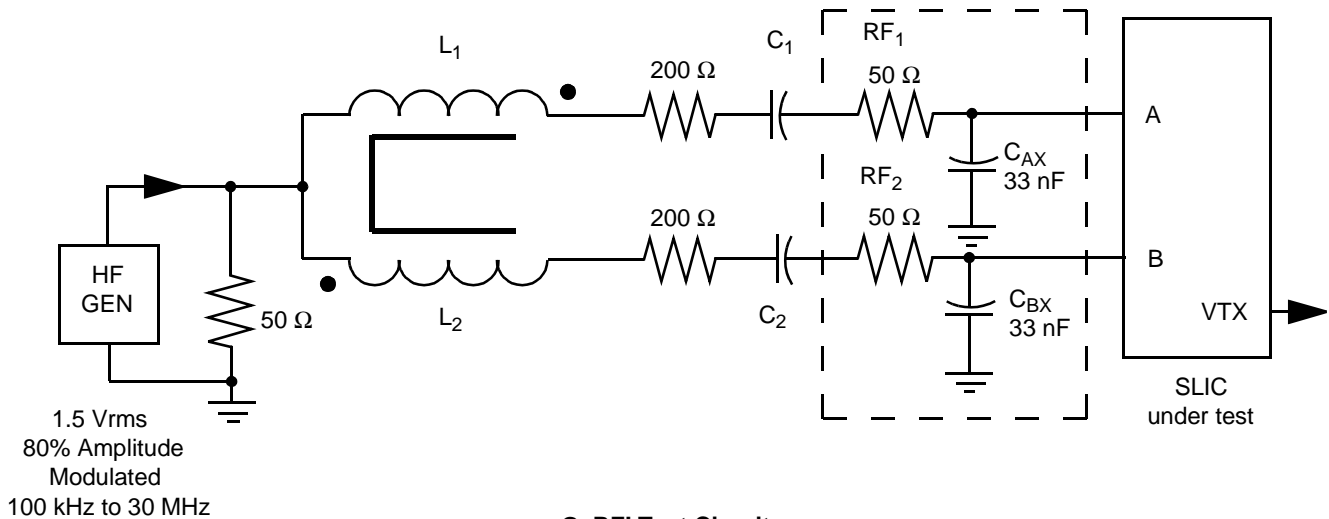

G. RFI Test Circuit

TEST CIRCUITS (continued)

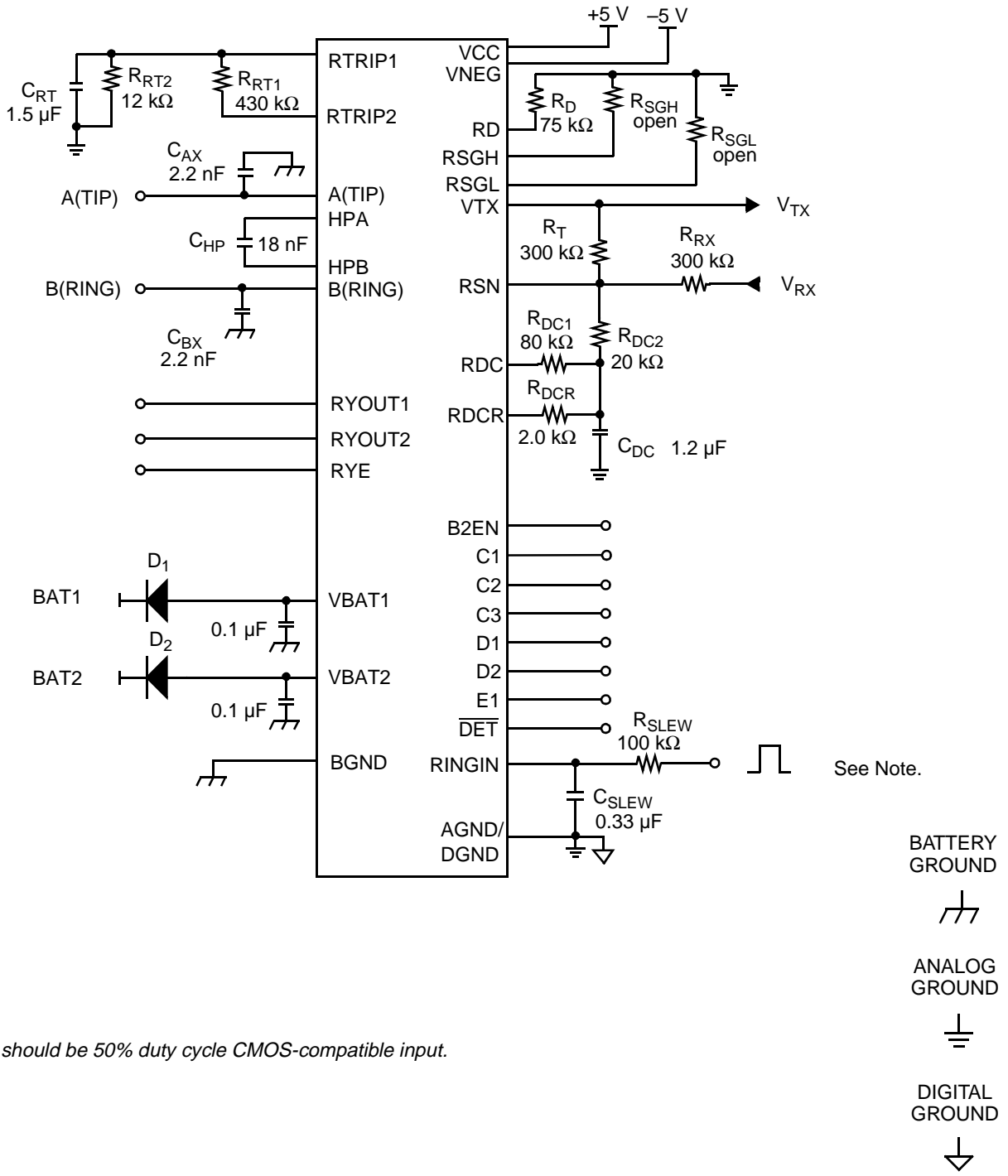

Note:

The input should be 50% duty cycle CMOS-compatible input.

H. Am79R70 Test Circuit

