

## SED1353 GRAPHICS LCD CONTROLLER

### ■ DESCRIPTION

The SED1353 is a dot matrix graphic LCD controller supporting resolutions up to 1024x1024. It is capable of displaying a maximum of 256 simultaneous colors out of a possible 4096 or 16 gray shades. Design flexibility allows the SED1353 to interface to either an MC68000 family microprocessor or an 8/16-bit MPU/bus with minimum external logic. The Static RAM (SRAM) interface used for the display buffer is optimized for speed and performance, supporting up to 128K bytes.

Two power save modes, combined with operating voltages of 2.7 volts through 5.5 volts, allow for a wide range of applications while providing minimum power consumption.

### ■ FEATURES

- pin compatible with the SED1352
- 16-bit 16 MHz MC68xxx MPU interface
- 8/16-bit MPU interface controlled by a READY (or WAIT#) signal
- option to use built-in index register or direct-mapping to access one of sixteen internal registers
- 2-terminal crystal or external oscillator support
- 8/16-bit SRAM interface configurations
- split screen display support allowing two different images to be simultaneously displayed
- virtual display support (displays images larger than the panel size through the use of panning)
- display modes:
  - black-and-white display
  - 2/4 bits per pixel, 4/16-level gray-scale display
  - 2/4/8 bits per pixel, 4/16/256-level color display
- two software power-save modes
- low power consumption
- display memory interface:
  - 128K bytes using one 64Kx16 SRAMs
  - 128K bytes using two 64Kx8 SRAMs
  - 64K bytes using two 32Kx8 SRAMs
  - 40K bytes using one 8Kx8 and one 32Kx8 SRAM
  - 32K bytes using one 32Kx8 SRAM
  - 16K bytes using two 8Kx8 SRAMs
  - 8K bytes using one 8Kx8 SRAM
- LCD panel configurations:
  - single-panel, single-drive passive display
  - dual-panel, dual-drive passive display
- maximum number of vertical lines:
  - 1,024 lines (single-panel, single-drive display)
  - 2,048 lines (dual-panel, dual-drive display)
- QFP5-100-S2 package (F0A)
- QFP15-100-STD package (F1A)

### ■ SYSTEM BLOCK DIAGRAM

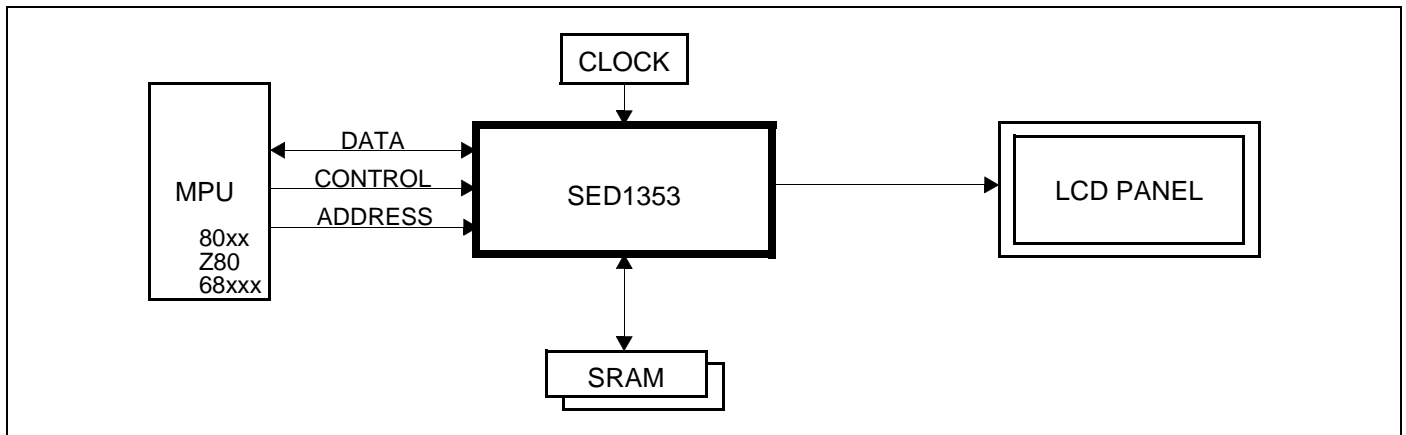

## SED1353

### ■ INTERFACE OPTIONS

#### Interface with 16-Bit MC68xxx MPU and 16K bytes SRAM (2 of 8K x 8)

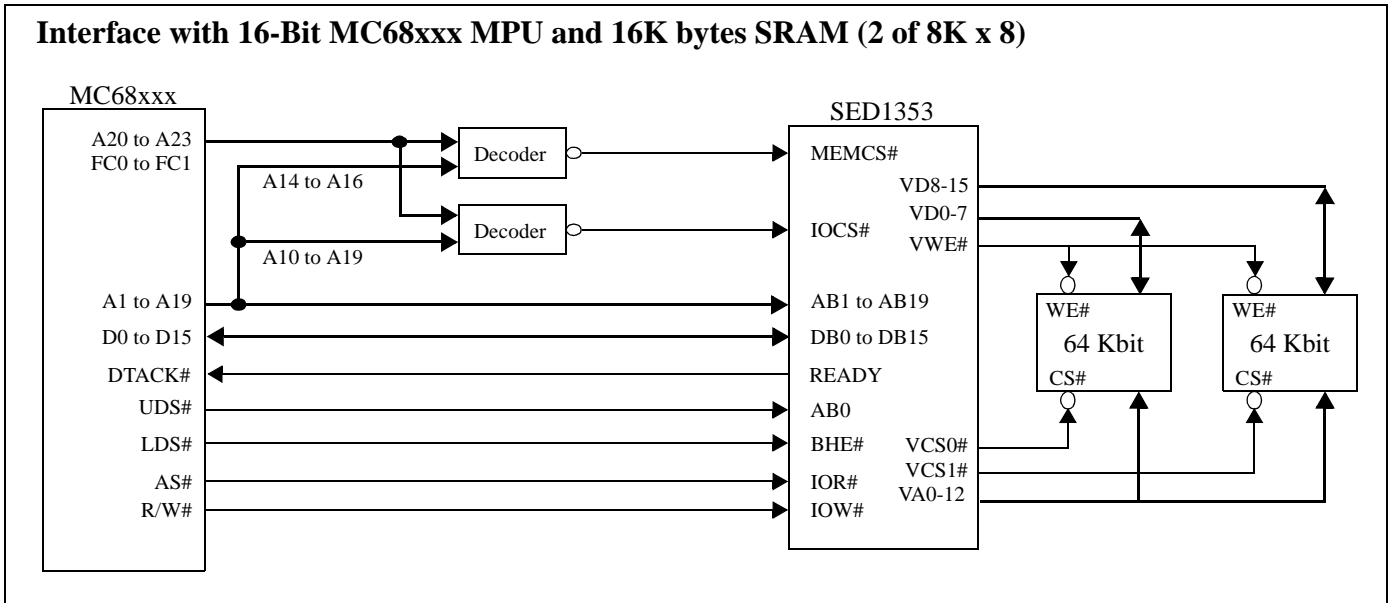

Note: Example implementation, actual may vary.

#### Interface with 8-Bit Z80 MPU and 16K bytes SRAM (2 of 8K x 8)

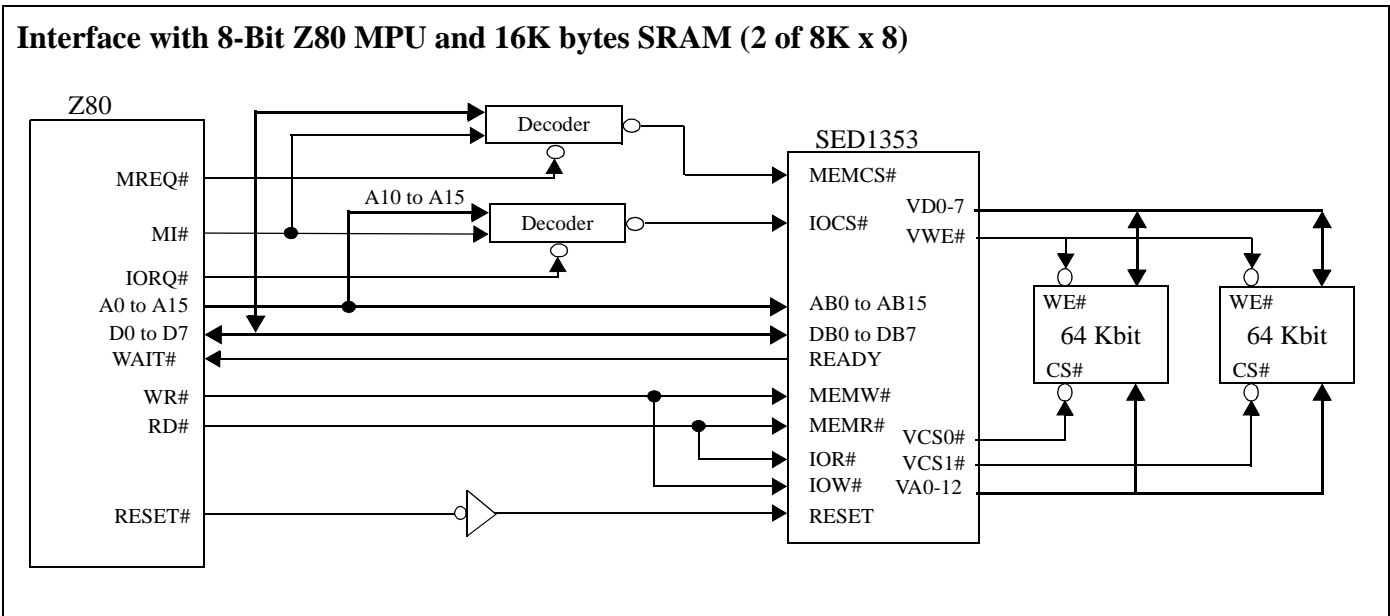

Note: Example implementation, actual may vary.

**Interface with 16-Bit 8086 MPU and 64K bytes SRAM (2 of 32K x 8)**

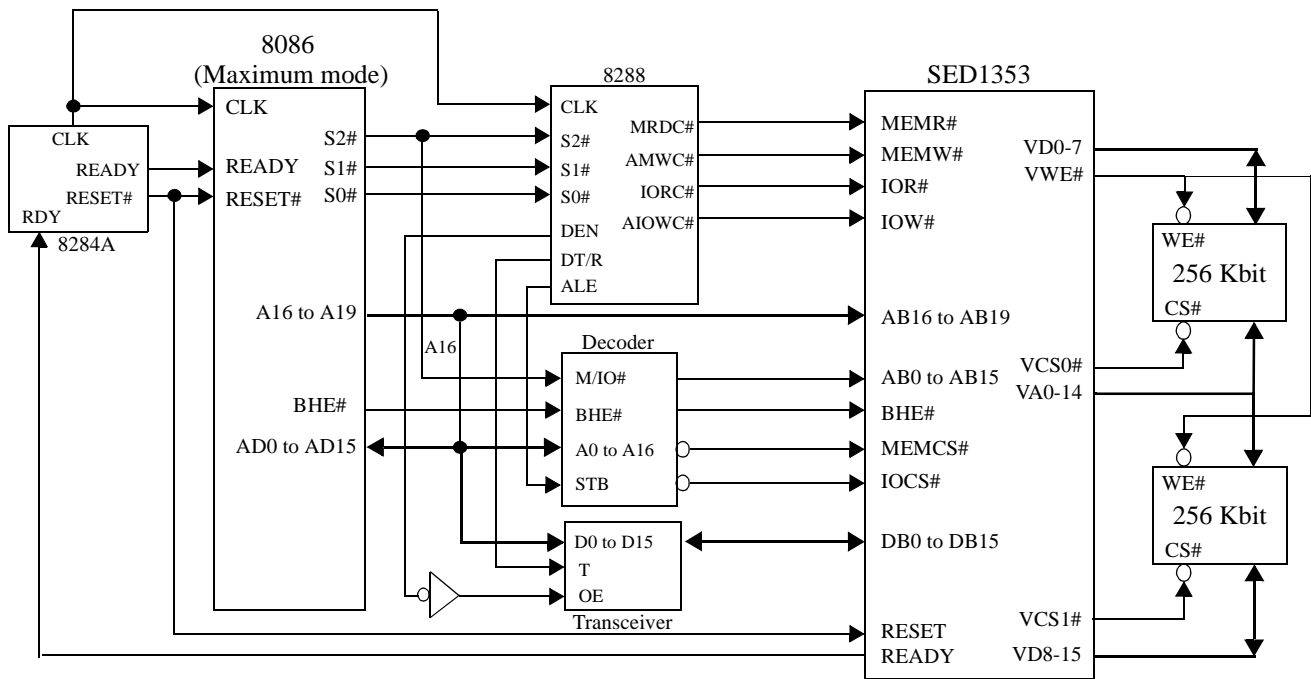

Note: Example implementation, actual may vary.

**Interface with 8-Bit ISA Bus and 40K bytes SRAM (1 of 8K x 8 and 1 of 32K x 8)**

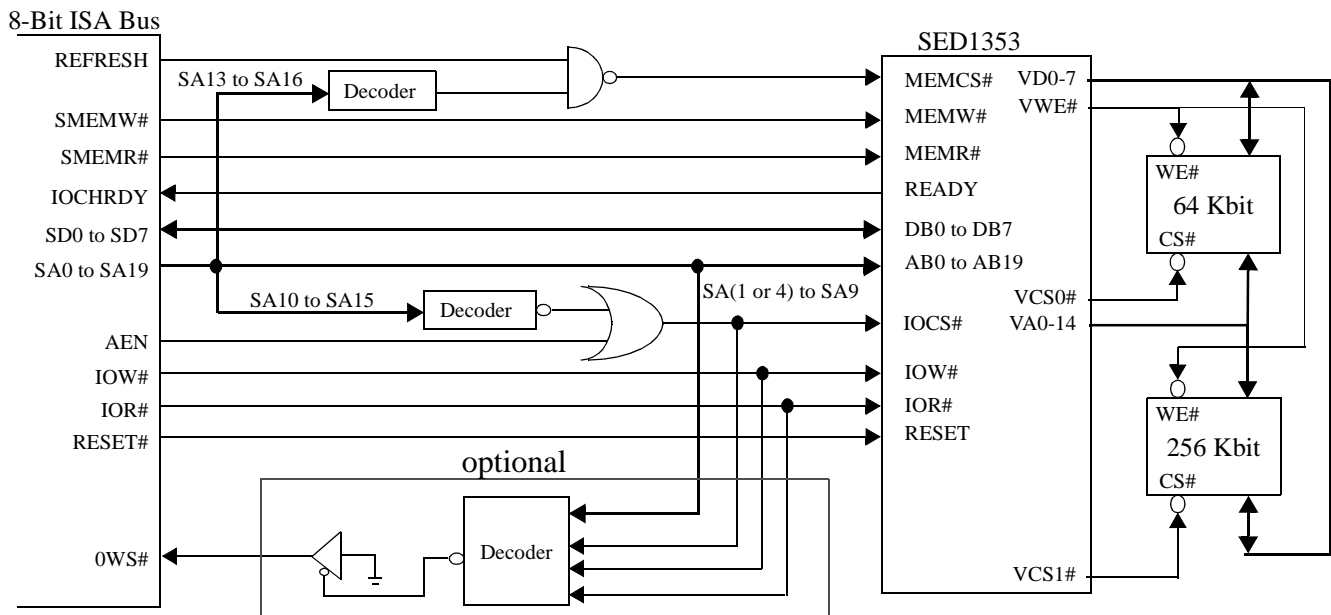

Note: Example implementation, actual may vary.

## SED1353

### Interface with 16-Bit ISA Bus and 128K bytes SRAM (1 of 128K x 8)

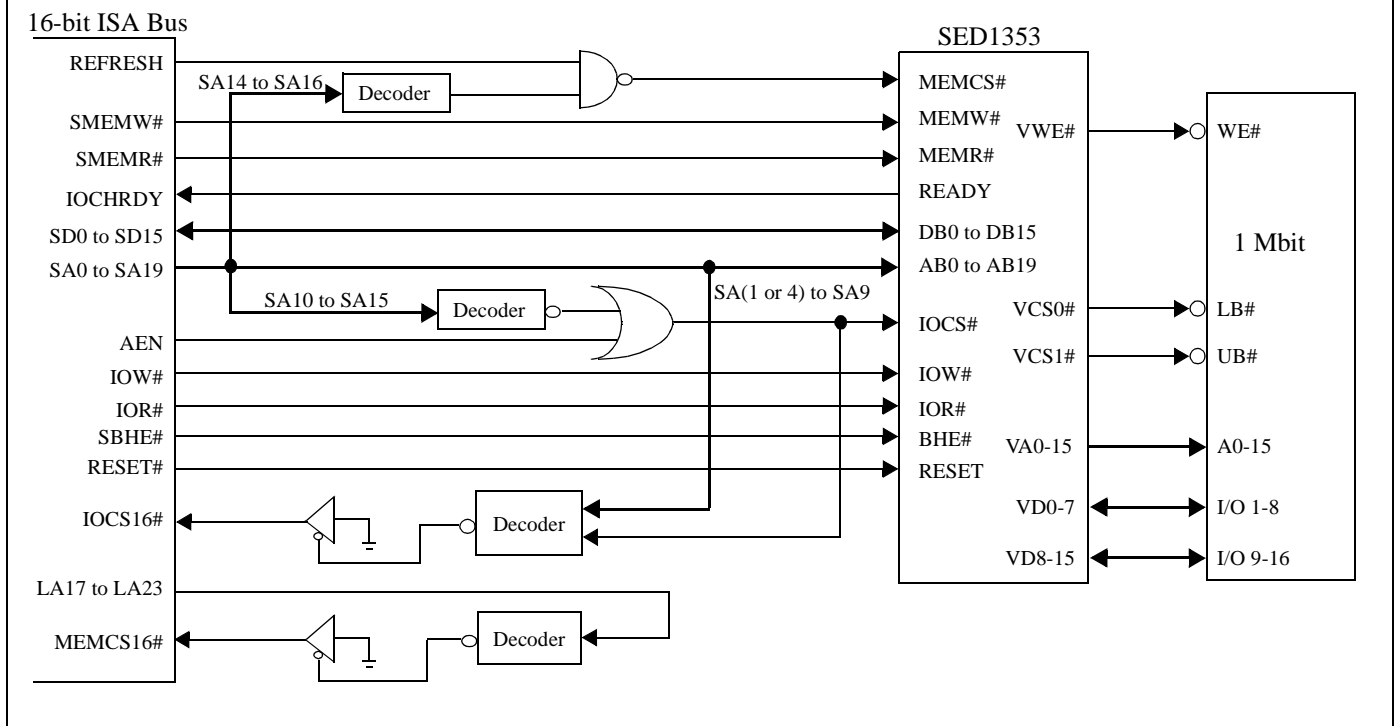

Note: Example implementation, actual may vary.

### ■ SUPPORTED RESOLUTIONS

Display RAM	Example Display Size				SRAM Type	CPU Interface	SRAM Interface
	Monochrome	4 Grays/ Colors	16 Grays/ Colors	256 Colors <sup>a</sup>			
	X Y	X Y	X Y	X Y			
8K byte	320 x 200	256 x 128	128 x 128	—	1 of 8Kx8	8-bit	8-bit
16K byte	512 x 256	320 x 200	200 x 160	160 x 100 <sup>a</sup>	2 of 8Kx8	8-bit	8-bit/16-bit
						16-bit	16-bit
32K byte	512 x 512	512 x 256	256 x 256	192 x 100 <sup>a</sup>	1 of 32Kx8	8-bit	8-bit
40K byte	1024 x 320	512 x 320	320 x 256	320 x 128 <sup>a</sup>	1 of 8Kx8 and 1 of 32Kx8	8-bit	8-bit
64K byte	1024 x 512	512 x 512	512 x 256	256 x 256 <sup>a</sup>	2 of 32Kx8	8-bit	8-bit/16-bit
						16-bit	16-bit
128K byte	1024 x 1024	1024 x 512	512 x 512	512 x 256 <sup>a</sup>	1 of 64Kx16	16-bit	16-bit
					2 of 64Kx8	16-bit	16-bit

a. 256 colors must use 16-bit SRAM interface

The above listed display sizes are examples based on bits/pixel and available memory.

■ BLOCK DIAGRAM

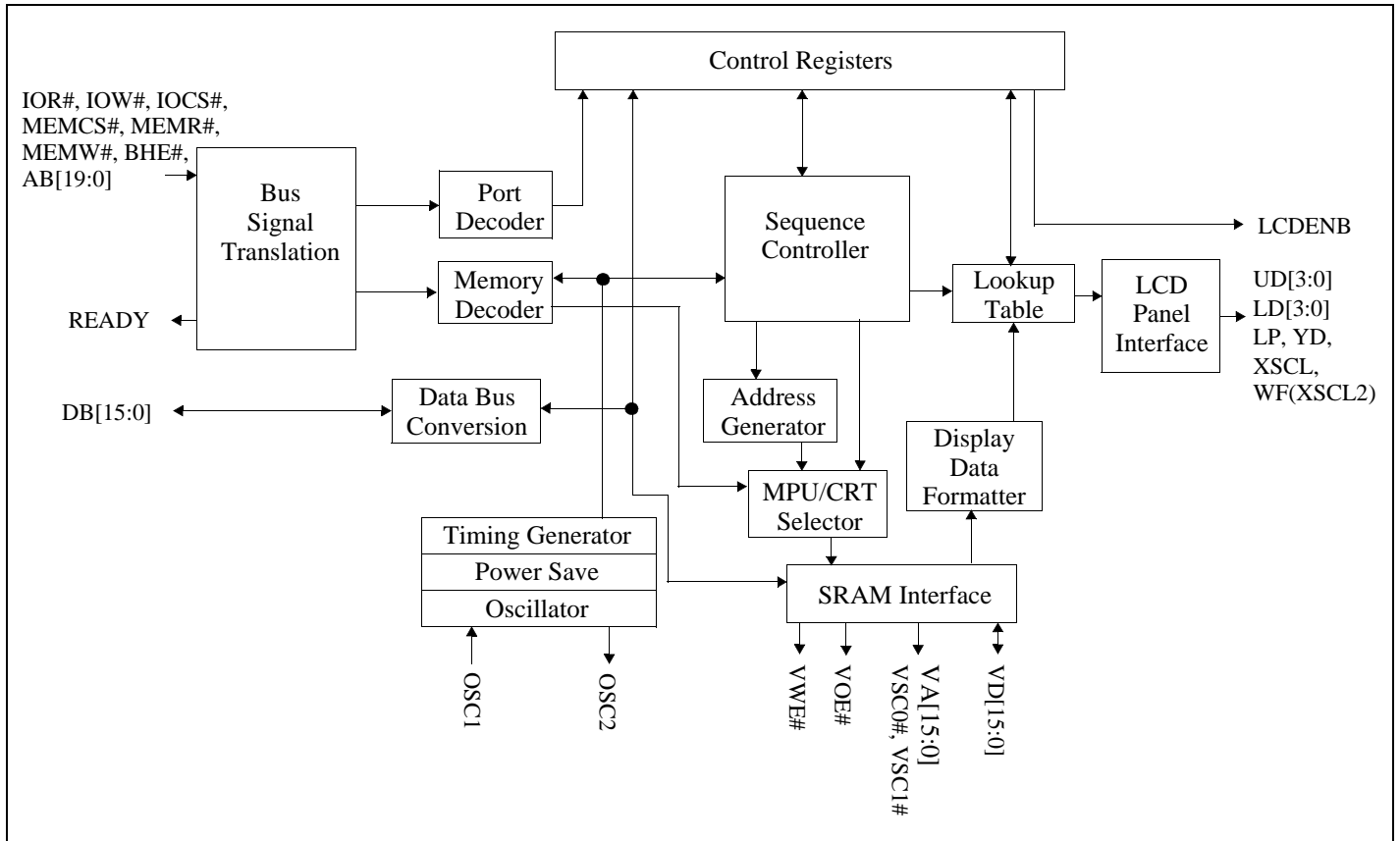

## SED1353

## ■ FUNCTIONAL BLOCK DESCRIPTION

**Bus Signal Translation**

According to configuration setting VD2, Bus Signal Translation translates either MC68000 type MPU signals or Ready type MPU signals to internal bus interface signals.

**Control Registers**

The Control Register contains 16 internal control and configuration registers. These registers can be accessed by either direct-mapping or using the built-in internal index register.

**Sequence Controller**

The Sequence Controller generates horizontal and vertical display timings according to the configuration registers settings.

**LCD Panel Interface**

The LCD Panel Interface performs frame rate modulation and output data pattern formatting for both passive monochrome and passive color LCD panels.

**Look-Up Table**

The Look-Up Table contains three 16x4-bit wide palettes. In gray shade modes, the "green" palette can be configured for the re-mapping of 16 possible shades of gray. In color modes, all three palettes can be configured for the re-mapping of 4096 possible colors.

**Port Decoder**

According to configuration settings VD1, VD12 - VD4, IOCS# and address lines AB9-1, the Port Decoder validates a given I/O cycle.

**Memory Decoder**

According to configuration settings VD15 - VD13, MEMCS# and address lines AB19-17, the Memory Decoder validates a given memory cycle.

**Data Bus Conversion**

According to configuration setting VD0, Data Bus Conversion maps the external data bus, either 8-bit or 16-bit, into the internal odd and even data bus.

**Address Generator**

The Address Generator generates display refresh addresses to be used to access display memory.

**MPU / CRT Selector**

The MPU / CRT Selector grants access to the display memory from either the MPU or the display refresh circuitry.

**Display Data Formatter**

The Display Data Formatter reads in the display data from the display memory and outputs the correct format for all supported gray shade and color selections.

**Clock Inputs / Timing**

Clock Inputs / Timing generates the internal master clock according to gray-level / color selected and display memory interface. The master clock (MCLK) can be:

- MCLK = input clock
- MCLK = 1/2 input clock
- MCLK = 1/4 input clock.

Pixel clock = input clock =  $f_{osc}$ .

**SRAM Interface**

The SRAM Interface generates the necessary signals to interface to the Display Memory (SRAM).

## ■ DC SPECIFICATIONS

### Absolute Maximum Ratings

Symbol	Parameter	Rating	Units
$V_{DD}$	Supply Voltage	$V_{SS} - 0.3$ to $+ 6.0$	V
$V_{IN}$	Input Voltage	$V_{SS} - 0.3$ to $V_{DD} + 0.5$	V
$V_{OUT}$	Output Voltage	$V_{SS} - 0.3$ to $V_{DD} + 0.5$	V
$T_{STG}$	Storage Temperature	-65 to 150	°C
$T_{SOL}$	Solder Temperature/Time	260 for 10 sec. max at lead	°C

### Recommended Operating Conditions

Symbol	Parameter	Condition	Min	Typ	Max	Units
$V_{DD}$	Supply Voltage	$V_{SS} = 0$ V	2.7	3.0/3.3/5.0	5.5	V
$V_{IN}$	Input Voltage		$V_{SS}$	--	$V_{DD}$	V
$I_{OPR}$	Operating Current	$f_{OSC} = 6$ MHz 256 colors		4.5/5.0/11		mA
$T_{OPR}$	Operating Temperature		-40	25	85	°C
$P_{TYP}$	Typical Active Power Consumption	$f_{OSC} = 6$ MHz 256 colors		13.5/16.5/55		mW

## SED1353

### Input Specifications

Symbol	Parameter	Condition	Min	Typ	Max	Units
$V_{IL}$	Low Level Input Voltage	$V_{DD} = 4.5V$ $V_{DD} = 3.0V$ $V_{DD} = 2.7V$			0.8 0.4 0.3	V
$V_{IH}$	High Level Input Voltage	$V_{DD} = 5.5V$ $V_{DD} = 3.6V$ $V_{DD} = 3.3V$	2.0 1.3 1.2			V
$V_{T+}$	Positive-going Threshold	$V_{DD} = 5.0$ $V_{DD} = 3.3$ $V_{DD} = 3.0$			2.4 1.4 1.3	V
$V_{T-}$	Negative-going Threshold	$V_{DD} = 5.0$ $V_{DD} = 3.3$ $V_{DD} = 3.0$	0.6 0.5 0.4			V
$V_H$	Hysteresis Voltage	$V_{DD} = 5.0$ $V_{DD} = 3.3$ $V_{DD} = 3.0$	0.1 0.1 0.1			V
$I_{IZ}$	Input Leakage Current	--	-1		1	$\mu A$
$C_{IN}$	Input Pin Capacitance	$f = 1 \text{ MHz}$ , $V_{DD} = 0V$			12	pF
$R_{PD}$	Pull Down Resistance	$V_{DD} = 5.0V$ $V_I = V_{DD}$	50	100	200	k $\Omega$
$R_{PD}$	Pull Down Resistance	$V_{DD} = 3.3V$ $V_I = V_{DD}$	90	180	360	k $\Omega$
$R_{PD}$	Pull Down Resistance	$V_{DD} = 3.0V$ $V_I = V_{DD}$	100	200	400	k $\Omega$



Output Specifications

Symbol	Parameter	Condition	Min	Typ	Max	Units
$V_{OL} (5.0V)$	Low Level Output Voltage Type 1 - TS1D2, CO1 Type 2 - TS2, CO2 Type 3 - TS3, CO3, CO3S	$V_{DD} = \text{Min}$ $I_{OL} = 4 \text{ mA}$ $I_{OL} = 8 \text{ mA}$ $I_{OL} = 12 \text{ mA}$			0.4	V
$V_{OL} (3.3V)$	Low Level Output Voltage Type 1 - TS1D2, CO1 Type 2 - TS2, CO2 Type 3 - TS3, CO3, CO3S	$V_{DD} = \text{Min}$ $I_{OL} = 2 \text{ mA}$ $I_{OL} = 4 \text{ mA}$ $I_{OL} = 6 \text{ mA}$			0.3	V
$V_{OL} (3.0V)$	Low Level Output Voltage Type 1 - TS1D2, CO1 Type 2 - TS2, CO2 Type 3 - TS3, CO3, CO3S	$V_{DD} = \text{Min}$ $I_{OL} = 1.8 \text{ mA}$ $I_{OL} = 3.5 \text{ mA}$ $I_{OL} = 5 \text{ mA}$			0.3	V
$V_{OH} (5.0V)$	High Level Output Voltage Type 1 - TS1D2, CO1 Type 2 - TS2, CO2 Type 3 - TS3, CO3, CO3S	$V_{DD} = \text{Min}$ $I_{OH} = -4 \text{ mA}$ $I_{OH} = -8 \text{ mA}$ $I_{OH} = -12 \text{ mA}$	$V_{DD}-0.4$			V
$V_{OH} (3.3V)$	Low Level Output Voltage Type 1 - TS1D2, CO1 Type 2 - TS2, CO2 Type 3 - TS3, CO3, CO3S	$V_{DD} = \text{Min}$ $I_{OL} = -2 \text{ mA}$ $I_{OL} = -4 \text{ mA}$ $I_{OL} = -6 \text{ mA}$	$V_{DD}-0.3$			V
$V_{OH} (3.0V)$	High Level Output Voltage Type 1 - TS1D2, CO1 Type 2 - TS2, CO2 Type 3 - TS3, CO3, CO3S	$V_{DD} = \text{Min}$ $I_{OH} = -1.8 \text{ mA}$ $I_{OH} = -3.5 \text{ mA}$ $I_{OH} = -5 \text{ mA}$	$V_{DD}-0.3$			V
$I_{OZ}$	Output Leakage Current	--	-1		1	$\mu\text{A}$
$C_{OUT}$	Output Pin Capacitance	$f = 1 \text{ MHz}$ , $V_{DD} = 0V$			12	pF
$C_{BID}$	Bidirectional Pin Capacitance	$f = 1 \text{ MHz}$ , $V_{DD} = 0V$			12	pF

SED1353

■ SED1353F0A PIN OUT

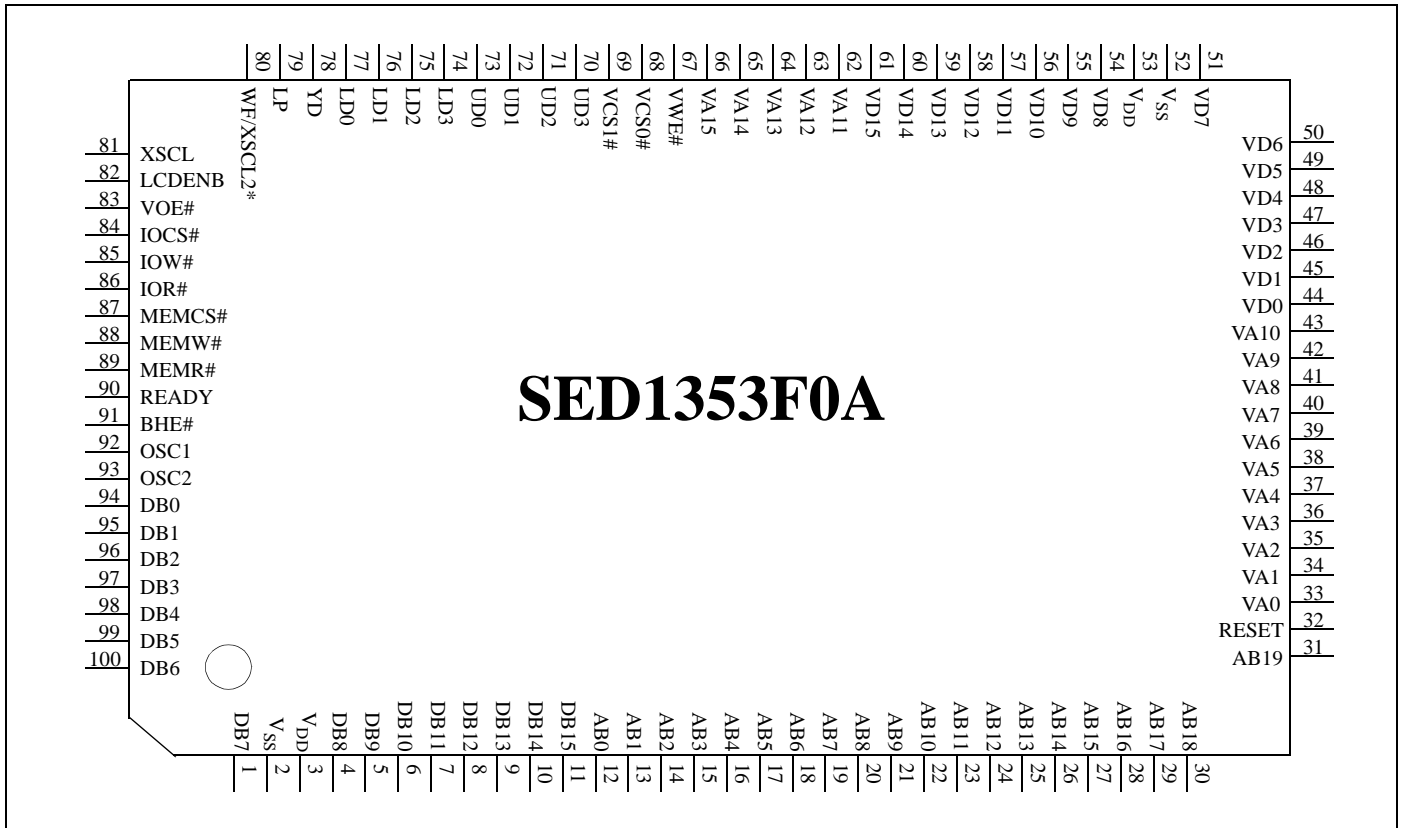

- \* Pin 80 = WF in all display modes except format 1 for 8-bit single color panel.
- \* Pin 80 = XSC2 in format 1 for 8-bit single color panel.

■ SED1353F1A PIN OUT

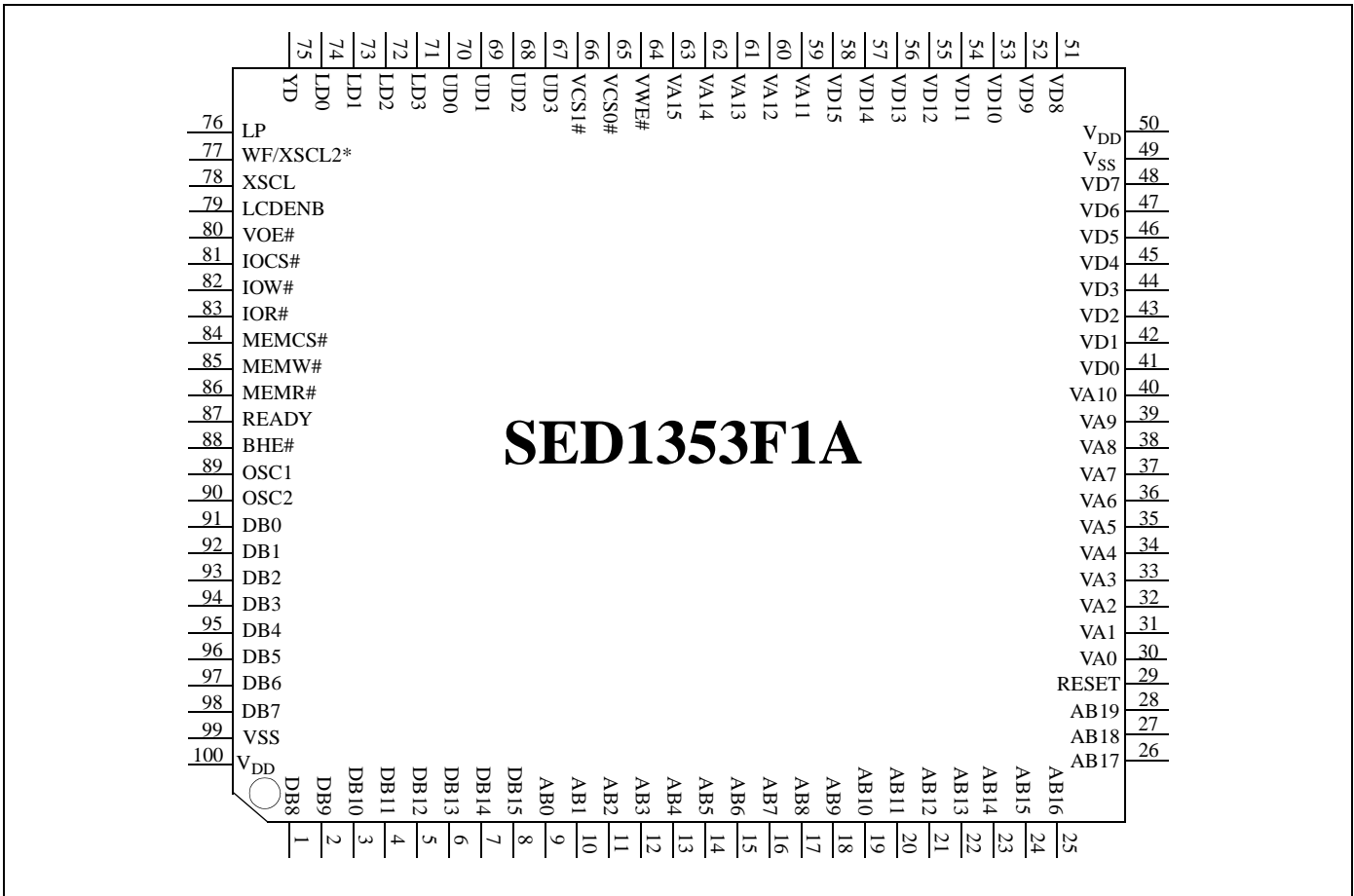

\* Pin 77 = WF in all display modes except format 1 for 8-bit single color panel.

\* Pin 77 = XSCL2 in format 1 for 8-bit single color panel.

## SED1353

### ■ SED1353D0A PIN OUT

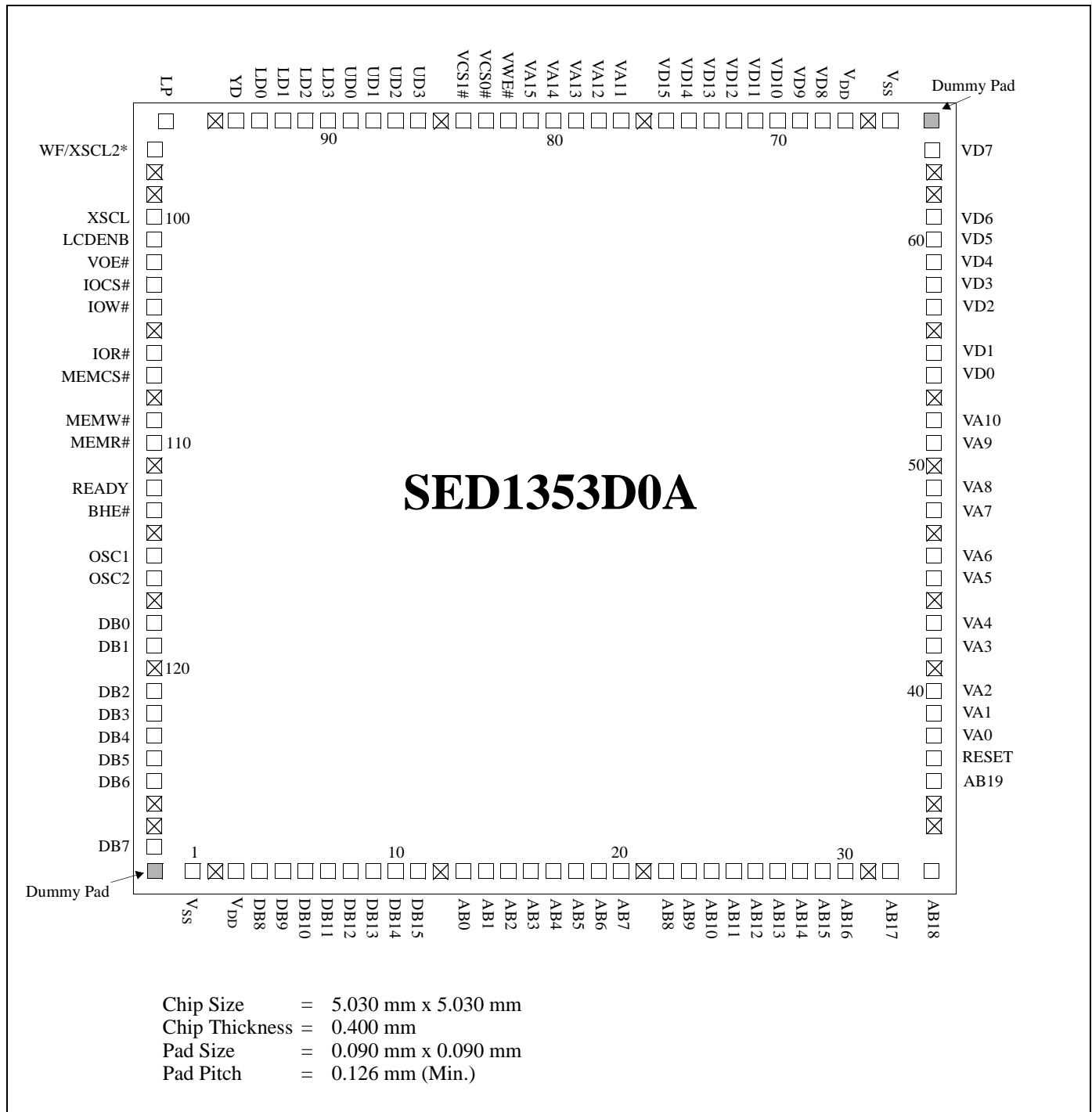

\* Pad 97 = WF in all display modes except format 1 for 8-bit single color panel.

\* Pad 97 = XSCL2 in format 1 for 8-bit single color panel.

PAD Coordinates

Pad No.	Pin Name	Pad Center Coordinate	
		X	Y
1	VSS	-2.165	-2.390
2	---	-2.000	-2.390
3	VDD	-1.840	-2.390
4	DB8	-1.685	-2.390
5	DB9	-1.535	-2.390
6	DB10	-1.388	-2.390
7	DB11	-1.246	-2.390
8	DB12	-1.106	-2.390
9	DB13	-0.969	-2.390
10	DB14	-0.835	-2.390
11	DB15	-0.703	-2.390
12	---	-0.573	-2.390
13	AB0	-0.444	-2.390
14	AB1	-0.317	-2.390
15	AB2	-0.190	-2.390
16	AB3	-0.063	-2.390
17	AB4	0.063	-2.390
18	AB5	0.190	-2.390
19	AB6	0.317	-2.390
20	AB7	0.444	-2.390
21	---	0.573	-2.390
22	AB8	0.703	-2.390
23	AB9	0.835	-2.390
24	AB10	0.969	-2.390
25	AB11	1.106	-2.390
26	AB12	1.246	-2.390
27	AB13	1.388	-2.390
28	AB14	1.535	-2.390
29	AB15	1.685	-2.390
30	AB16	1.840	-2.390
31	---	2.000	-2.390
32	AB17	2.165	-2.390
33	AB18	2.390	-2.340
34	---	2.390	-2.000
35	---	2.390	-1.840
36	AB19	2.390	-1.685

Pad No.	Pin Name	Pad Center Coordinate	
		X	Y
37	RESET	2.390	-1.535
38	VA0	2.390	-1.388
39	VA1	2.390	-1.246
40	VA2	2.390	-1.106
41	---	2.390	-0.969
42	VA3	2.390	-0.835
43	VA4	2.390	-0.703
44	---	2.390	-0.573
45	VA5	2.390	-0.444
46	VA6	2.390	-0.317
47	---	2.390	-0.190
48	VA7	2.390	-0.063
49	VA8	2.390	0.063
50	---	2.390	0.190
51	VA9	2.390	0.317
52	VA10	2.390	0.444
53	---	2.390	0.573
54	VD0	2.390	0.703
55	VD1	2.390	0.835
56	---	2.390	0.969
57	VD2	2.390	1.106
58	VD3	2.390	1.246
59	VD4	2.390	1.388
60	VD5	2.390	1.535
61	VD6	2.390	1.685
62	---	2.390	1.840
63	---	2.390	2.000
64	VD7	2.390	2.165
65	VSS	2.165	2.390
66	---	2.000	2.390
67	VDD	1.840	2.390
68	VD8	1.685	2.390
69	VD9	1.535	2.390
70	VD10	1.388	2.390
71	VD11	1.246	2.390
72	VD12	1.106	2.390

## SED1353

Pad No.	Pin Name	Pad Center Coordinate	
		X	Y
73	VD13	0.969	2.390
74	VD14	0.835	2.390
75	VD15	0.703	2.390
76	---	0.573	2.390
77	VA11	0.444	2.390
78	VA12	0.317	2.390
79	VA13	0.190	2.390
80	VA14	0.063	2.390
81	VA15	-0.063	2.390
82	VWE#	-0.190	2.390
83	VCS0#	-0.317	2.390
84	VCS1#	-0.444	2.390
85	---	-0.573	2.390
86	UD3	-0.703	2.390
87	UD2	-0.835	2.390
88	UD1	-0.969	2.390
89	UD0	-1.106	2.390
90	LD3	-1.246	2.390
91	LD2	-1.388	2.390
92	LD1	-1.535	2.390
93	LD0	-1.685	2.390
94	YD	-1.840	2.390
95	---	-2.000	2.390
96	LP	-2.340	2.390
97	WF/XSCL2	-2.390	2.165
98	---	-2.390	2.000
99	---	-2.390	1.840
100	XSCL	-2.390	1.685
101	LCDENB	-2.390	1.535

Pad No.	Pin Name	Pad Center Coordinate	
		X	Y
102	VOE#	-2.390	1.388
103	IOCS#	-2.390	1.246
104	IOW#	-2.390	1.106
105	---	-2.390	0.969
106	IOR#	-2.390	0.835
107	MEMCS#	-2.390	0.703
108	---	-2.390	0.573
109	MEMW#	-2.390	0.444
110	MEMR#	-2.390	0.317
111	---	-2.390	0.190
112	READY	-2.390	0.063
113	BHE#	-2.390	-0.063
114	---	-2.390	-0.190
115	OSC1	-2.390	-0.317
116	OSC2	-2.390	-0.444
117	---	-2.390	-0.573
118	DB0	-2.390	-0.703
119	DB1	-2.390	-0.835
120	---	-2.390	-0.969
121	DB2	-2.390	-1.106
122	DB3	-2.390	-1.246
123	DB4	-2.390	-1.388
124	DB5	-2.390	-1.535
125	DB6	-2.390	-1.685
126	---	-2.390	-1.840
127	---	-2.390	-2.000
128	DB7	-2.390	-2.165
129	Dummy Pad	2.390	2.390
130	Dummy Pad	-2.390	-2.390

■ PIN DESCRIPTION

Key

- I = Input
- O = Output
- I/O = Bidirectional
- P = Power

Bus Interface

Pin Name	Type	F0A Pin #	F1A Pin #	D0A Pad #	Description
DB0-DB15	I/O	94 - 100, 1, 4 - 11	91 - 98, 1 - 8	118-119, 121-125, 128, 4-11	These pins are connected to the system data bus. In 8-bit bus mode, DB8-DB15 must be tied to $V_{DD}$ .
AB0	I	12	9	13	In MC68000 MPU interface, this pin is connected to the Upper Data Strobe (UDS#) pin of MC68000. In other bus interfaces, this pin is connected to the system address bus.
AB1-AB19	I	13 - 31	10 - 28	14-20, 22-30, 32-33, 36	These pins are connected to the system address bus.
BHE#	I	91	88	113	In MC68000 MPU interface, this pin is connected to the Lower Data Strobe (LDS#) pin of MC68000. In other bus interfaces, this pin is the Byte High Enable input for use with 16-bit system. In 8-bit bus mode, tie BHE# input to $V_{DD}$ .
IOCS#	I	84	81	103	Active low input to select one of fifteen internal registers.
IOW#	I	85	82	104	In MC68000 MPU interface, this pin is connected to the R/W# pin of MC68000. This input pin will define whether the data transfer is a read (active high) or write (active low) cycle. In other bus interfaces, this is the active low input to write data into an internal register.
IOR#	I	86	83	106	In MC68000 MPU interface, this pin is connected to the AS# pin of MC68000. This input pin will indicate a valid address is available on the address bus. In other bus interfaces, this is the active low input to read data from an internal register.
MEMCS#	I	87	84	107	Active low input to indicate the attempt to access the display memory.
MEMW#	I	88	85	109	Active low input to write data to the display memory. This pin should be tied to $V_{DD}$ in an MC68000 MPU interface.
MEMR#	I	89	86	110	Active low input to read data from the display memory. This pin should be tied to $V_{DD}$ in an MC68000 MPU interface.
READY	O	90	87	112	For MC68000 MPU interface, this pin is connected to the DTACK# pin of MC68000 and will be driven low when ever a data transfer is complete. In other bus interfaces, this output is driven low to force the system to insert wait states when needed.  READY is placed in a high-impedance (Hi-Z) state after the transfer is completed.
RESET	I	32	29	37	Active high input to force all signals to their inactive states.

## SED1353

### Display Memory Interface

Pin Name	Type	F0A Pin #	F1A Pin #	D0A Pad #	Description
VD0-VD15	I/O	44 - 51, 54 - 61	41 - 48, 51 - 58	54-55, 57-61, 64, 68-75	These pins are connected to the display memory data bus. For 16-bit interface, VD0-VD7 are connected to the display memory data bus of even byte addresses and VD8-VD15 are connected to the display memory data bus of odd byte addresses. The output drivers of these pins are tri-stated when RESET is high.  On the falling edge of RESET the values of VD0-VD15 are latched into the chip to configure various hardware options.
VA0-VA15	O	33 - 43, 62 - 66	30 - 40 59 - 63	38-40, 42-43, 45-46, 48-49, 51-52, 77-81	These pins are connected to the display memory address bus.
VCS1#	O	69	66	84	Active low chip-select output to the second or odd byte address SRAM.
VCS0#	O	68	65	83	Active low chip-select output to the first or even byte address SRAM.
VWE#	O	67	64	82	Active low output used for writing data to the display memory. This pin is connected to the WE# input of the SRAMs.
VOE#	O	83	80	102	Active low output to enable reading of data from the display memory. This pin is connected to the OE# input of the SRAMs.

### LCD Interface

Pin Name	FPDI-1™ Pin Name <sup>a</sup>	Type	F0A Pin #	F1A Pin #	D0A Pad #	Description
UD3-UD0 LD3-LD0	UD3-UD0 LD3-LD0	O	70 - 73 74 - 77	67 - 70 71 - 74	86 - 89 90 - 93	Panel display data bus. The data format depends on the specific panel connected. For 4-bit single panels, these bits are driven 0 (low state).
XSCL	FPSHIFT	O	81	78	100	Display data shift clock. Data is shifted into the LCD X-drivers on the falling edge of this signal.
LP	FPLINE	O	79	76	96	Display data latch clock. The falling edge of this signal is used to latch a row of display data in the LCD X-drivers and to turn on the row driver (Y driver).
WF/XSCL2	MOD FPSHIFT2	O	80	77	97	For format 1 of 8-bit single color panels this is the second shift clock. For all other modes, this is the LCD backplane BIAS signal. This output toggles once every n LP periods, as programmed in AUX[05]
YD	FPFRAME	O	78	75	94	Vertical scanning start pulse. A logic '1' on this signal, sampled by the LCD module on the falling edge of LP, is used by the panel row driver (Y driver) to indicate the start of the vertical frame.
LCDENB	---	O	82	79	101	LCD enable signal output. It can be used externally to turn off the panel supply voltage and backlight.

a. VESA Flat Panel Display Interface Standard (FPDI-1™)



**Clock Inputs**

Pin Name	Type	F0A Pin #	F1A Pin #	D0A Pad #	Description
OSC1	I	92	89	115	This pin, along with OSC2 is the 2-terminal crystal interface when using a 2-terminal crystal as the clock input. If an external oscillator is used as a clock source, then this pin is the clock input.
OSC2	O	93	90	116	This pin, along with OSC1 is the 2-terminal crystal interface when using a 2-terminal crystal as the clock input. If an external oscillator is used as a clock source, then this pin should be left unconnected.

**Power Supply**

Pin Name	Type	F0A Pin #	F1A Pin #	D0A Pad #	Description
V <sub>DD</sub>	P	3, 53	50, 100	3, 67	Voltage supply.
V <sub>SS</sub>	P	2, 52	49, 99	1, 65	Voltage Ground.

■ **SUMMARY OF CONFIGURATION OPTIONS**

Pin Name	value on this pin at falling edge of RESET is used to configure: (1/0)	
	<b>1</b>	<b>0</b>
VD0	16-bit host bus interface	8-bit host bus interface
VD1	Use direct-mapping for I/O accesses	Use indexed mapping for I/O accesses
VD2	MC68000 MPU interface	MPU / Bus interface with memory accesses controlled by a READY (WAIT#) signal
VD3	Swap of high and low data bytes in 16-bit bus interface	No byte swap of high and low data bytes in 16-bit bus interface
VD12-VD4	Select I/O mapping address bits [9:1]. These nine bits are latched on power-up and are compared to the MPU address bits [9-1]. A valid I/O cycle combined with a valid address will enable the internal I/O decoder. Therefore, both types of I/O mapping are limited to even address boundaries to determine either the absolute or indexed I/O address of the first register. Note that a “valid I/O cycle” includes IOCS# being toggled low.	
VD15-VD13	Select memory mapping address bits [3:1] These three bits are latched on power-up and are compared to the MPU address bits [19-17]. A valid memory cycle combined with a valid address will enable the internal memory decoder. As only the three most significant bits of the address are compared, the maximum amount of memory supported is 128K bytes. Note that a “valid memory cycle” includes MEMCS# being toggled low.  When using 128K byte memory it must be mapped at an even address such that all 128K bytes is available without a change in state on A17, as this would invalidate the internal compare logic.	

**SED1353**

Example: If an ISA bus (no byte swap) with memory segment “A” and I/O location 300h are used, the corresponding settings of VD15-VD0 would be:

Pin Name	8-Bit ISA Bus		16-Bit ISA Bus	
	Index Register	Direct Mapping	Index Register	Direct Mapping
VD0	0	0	1	1
VD1	0	1	0	1
VD2	0	0	0	0
VD3	0	0	0	0
VD12-VD4	11 0000 000	11 0000 xxx	11 0000 000	11 0000 xxx
VD15-VD13	101	101	101	101

Where x = don't care; 1 = connected to pull-up resistor; 0 = not connected to pull-up resistor

■ MONOCHROME PASSIVE STN LCD PANEL INTERFACE

4-Bit Single Panel

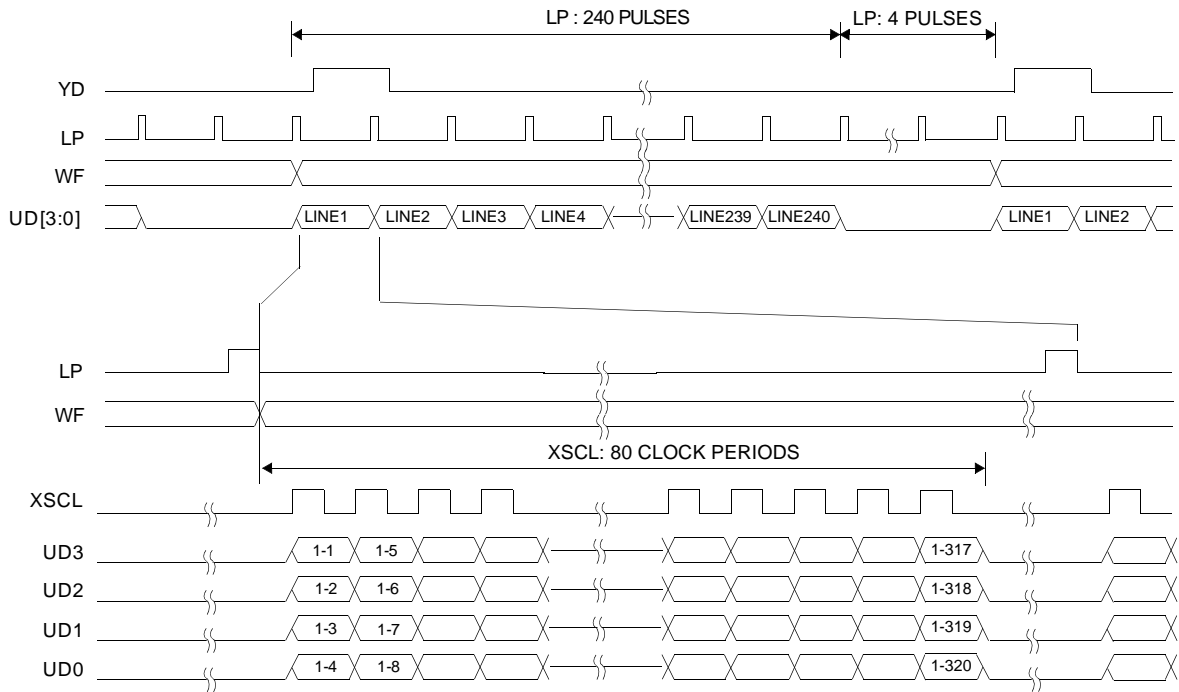

Example Timing for a 320x240 single panel

SED1353

MONOCHROME PASSIVE STN LCD PANEL INTERFACE

8-Bit Single Panel

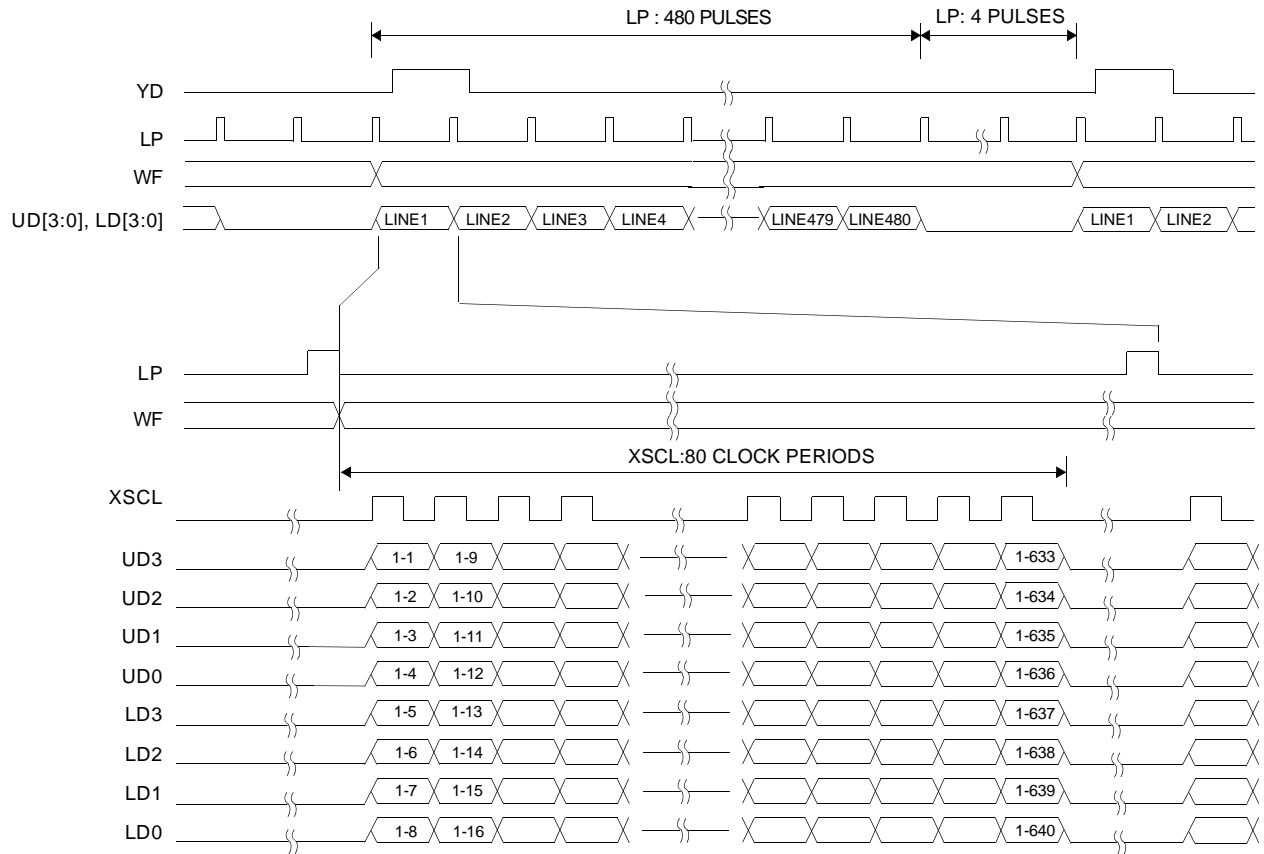

Example timing for a 640x480 panel

■ MONOCHROME PASSIVE STN LCD PANEL INTERFACE

8-Bit Dual Panel

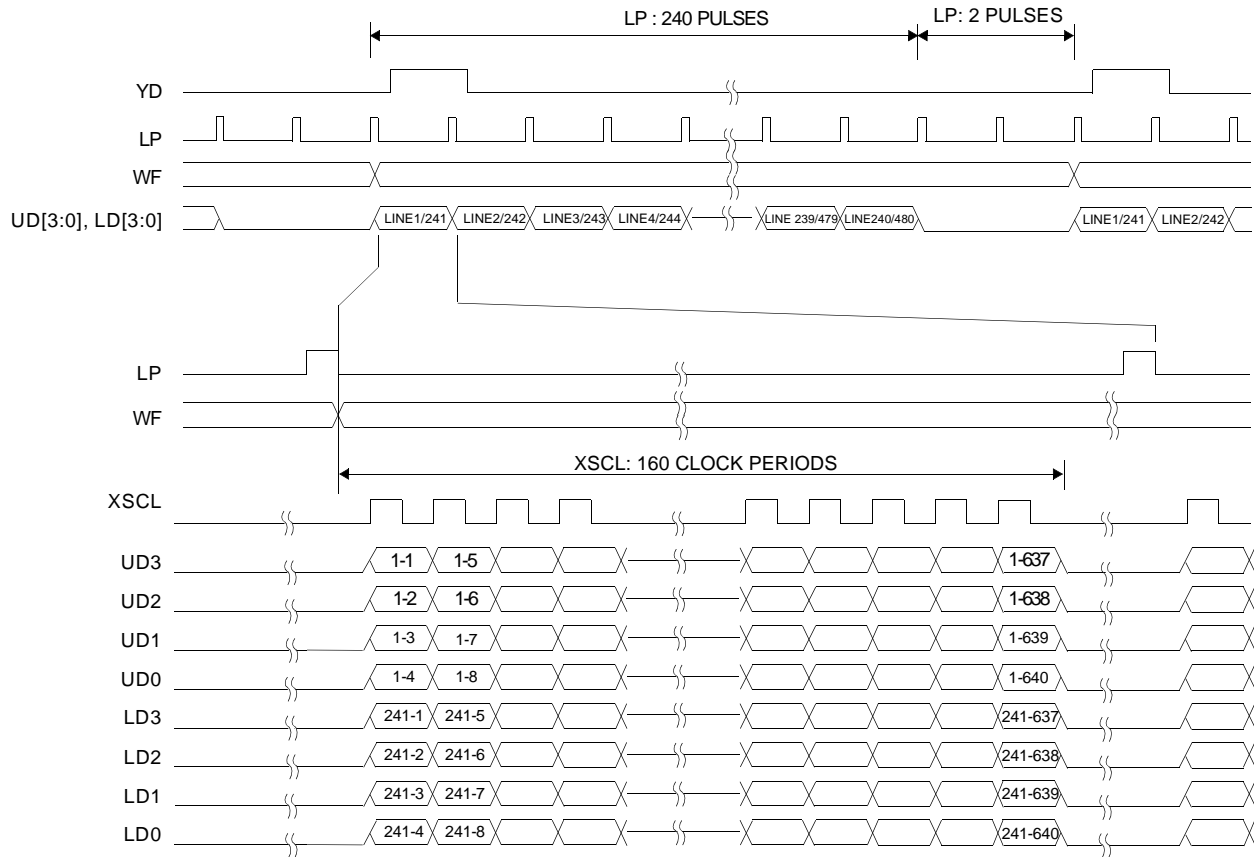

Example timing for a 640x480 panel

SED1353

■ COLOR PASSIVE STN LCD PANEL INTERFACE

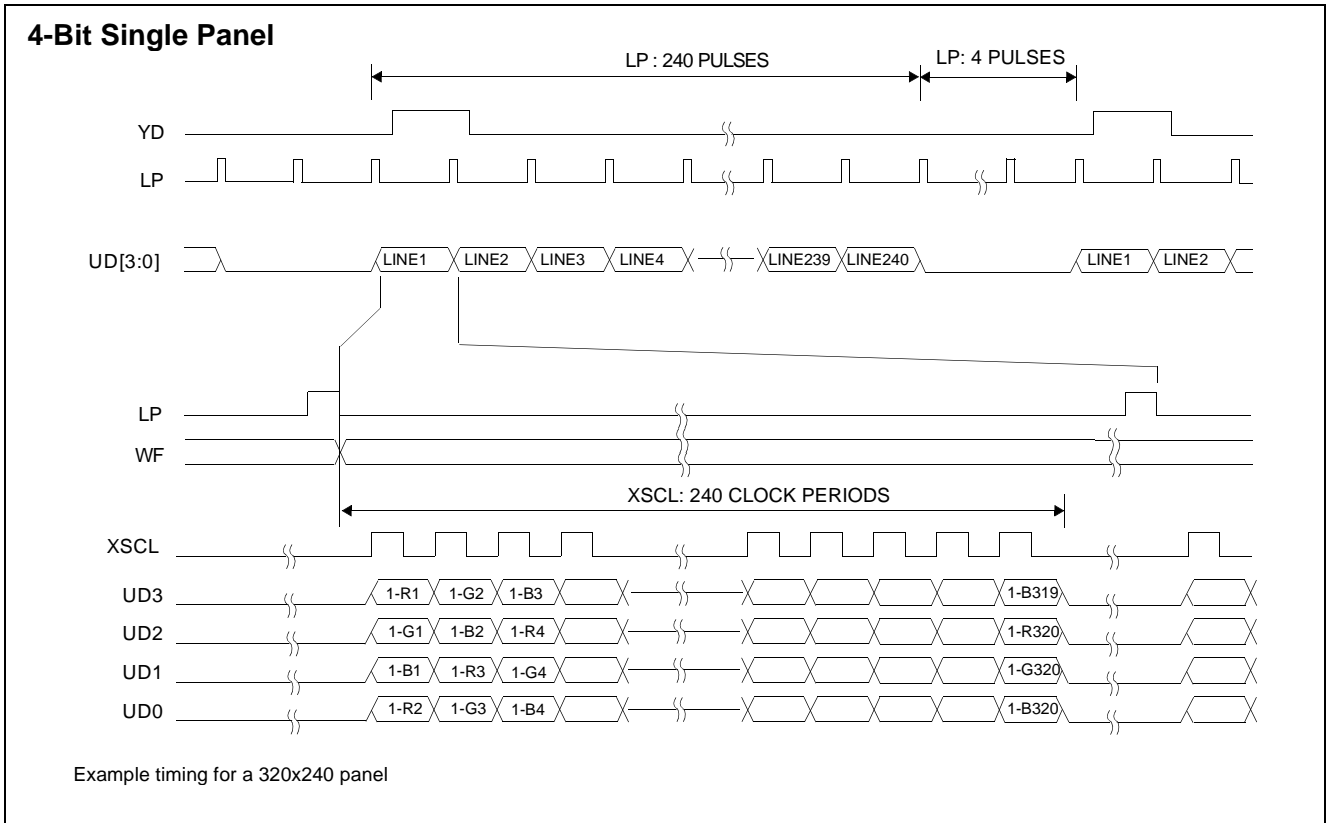

■ COLOR PASSIVE STN LCD PANEL INTERFACE

8-Bit Single Panel - Format 1

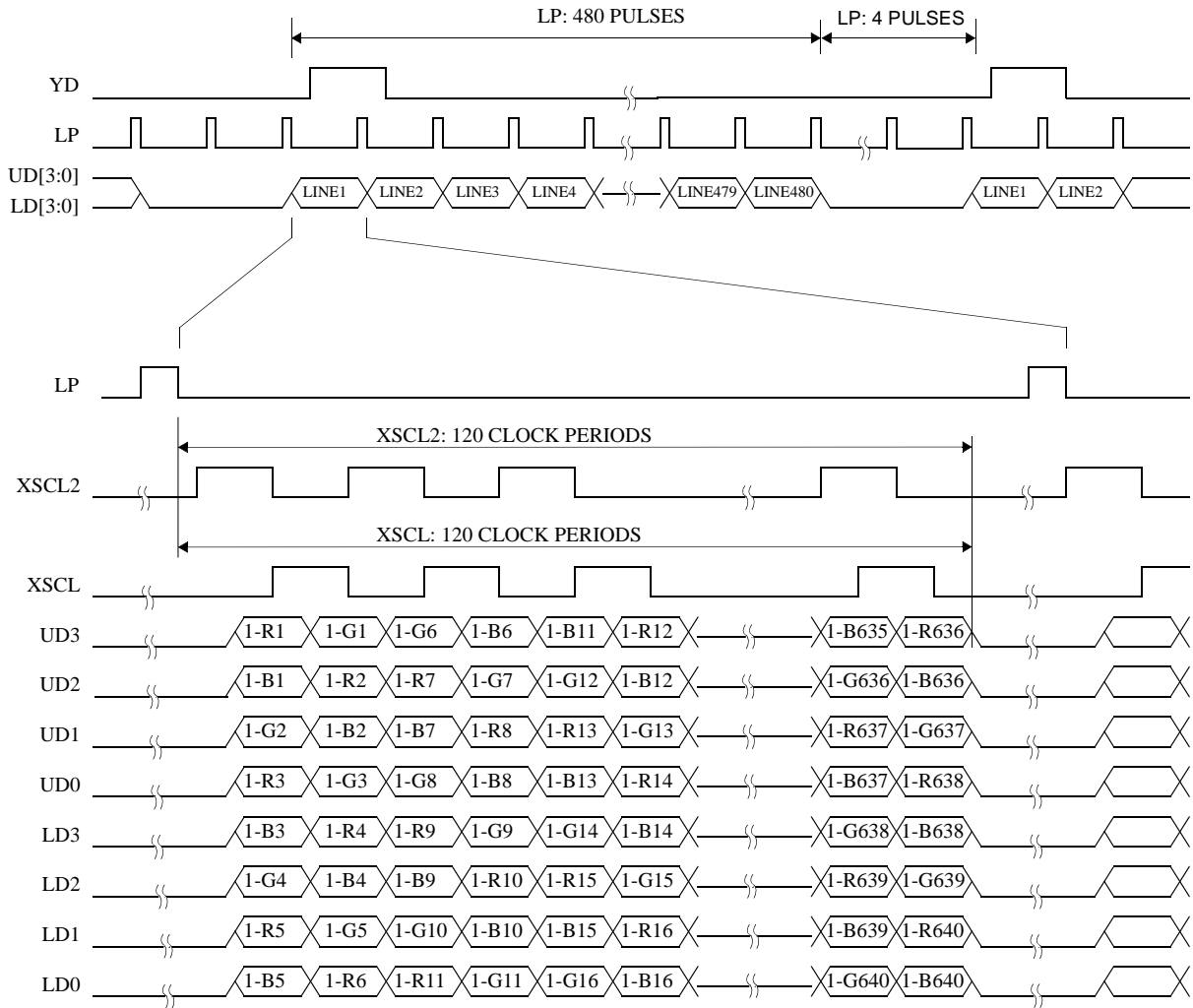

Example timing for a 640x480 panel

SED1353

■ COLOR PASSIVE STN LCD PANEL INTERFACE

8-Bit Single Panel - Format 2

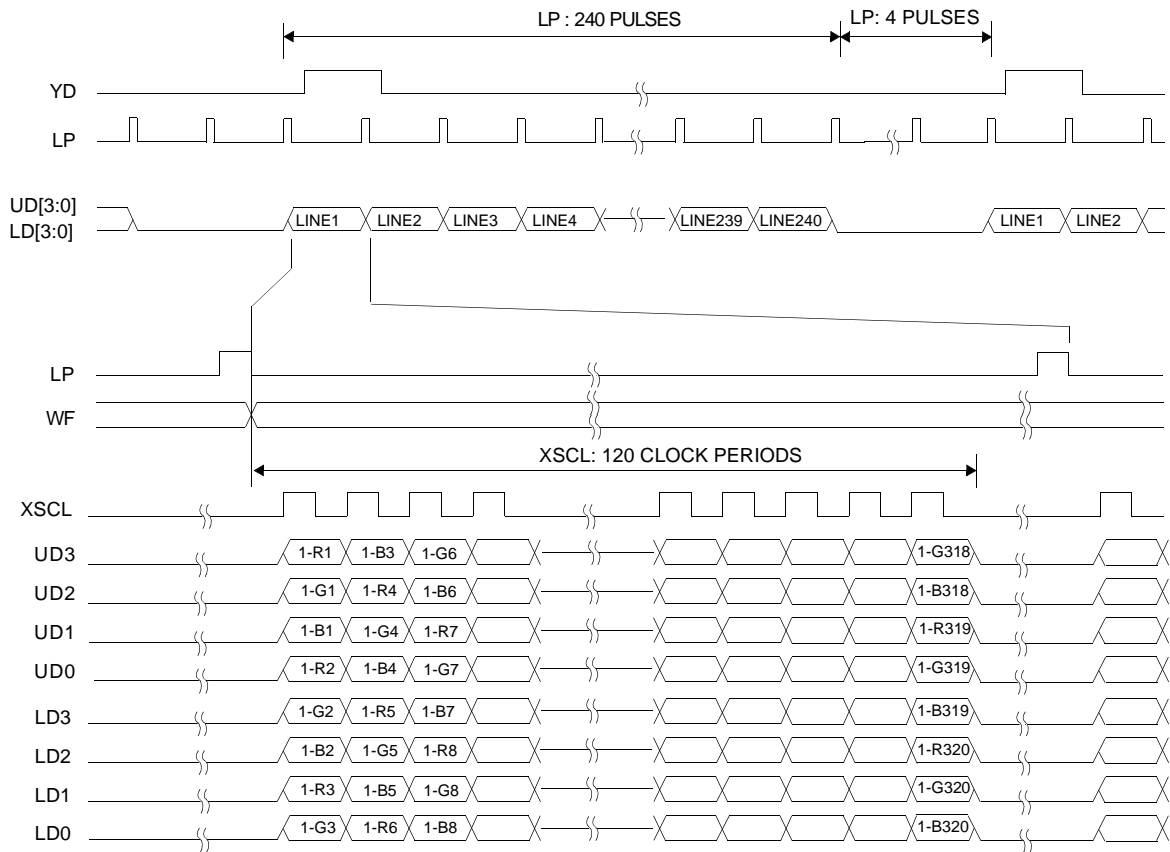

Example timing for a 320x240 panel



■ COLOR PASSIVE STN LCD PANEL INTERFACE

8-Bit Dual Panel

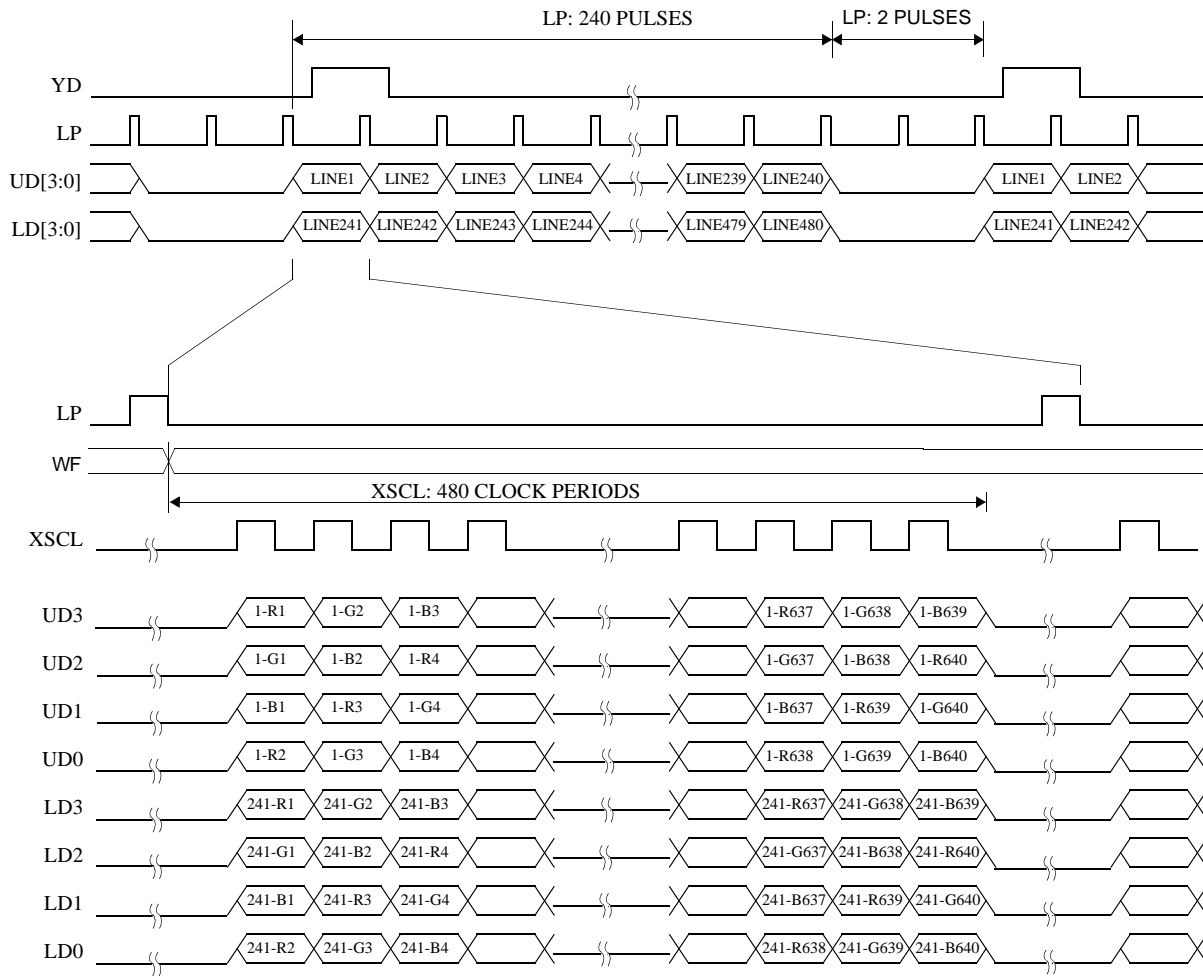

Example timing for a 640x480 panel

## SED1353

### ■ COLOR PASSIVE STN LCD PANEL INTERFACE

#### 16-Bit Single Panel With External Circuit

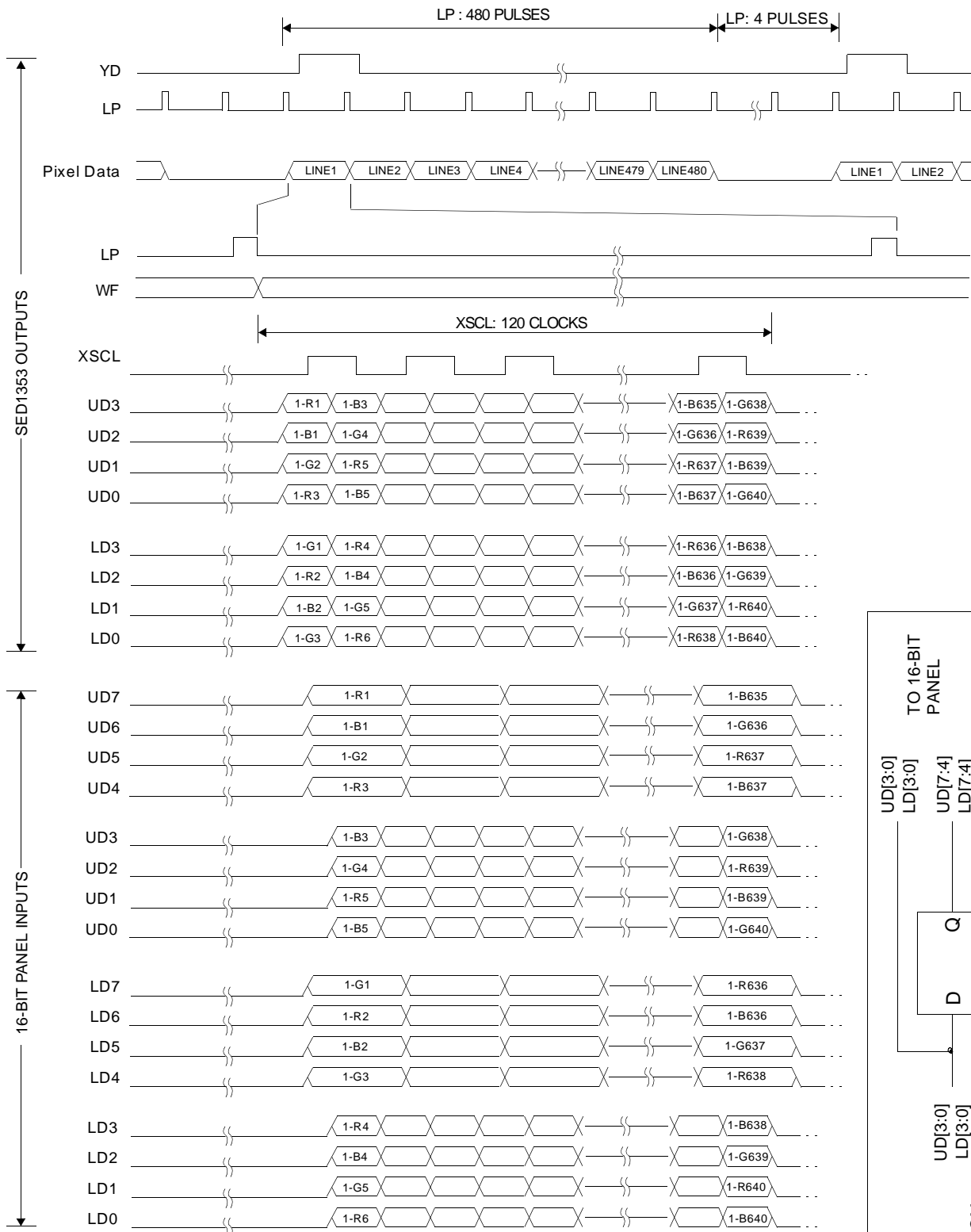

Example timing for a 640x480 panel

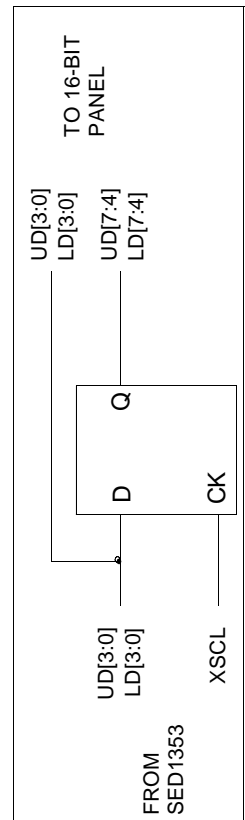

■ COLOR PASSIVE STN LCD PANEL INTERFACE

16-Bit Dual Panel With External Circuit

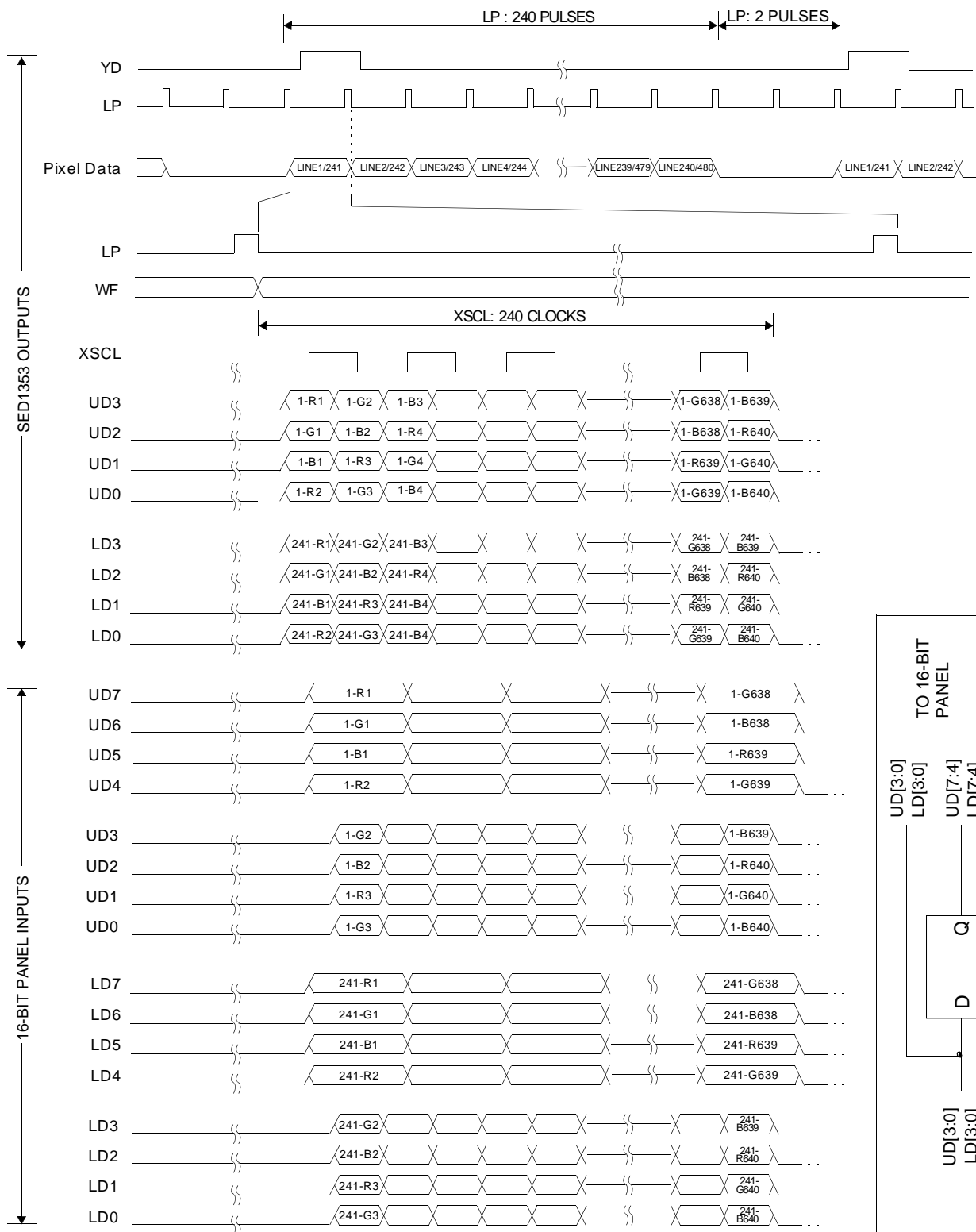

Example timing for a 640x480 panel

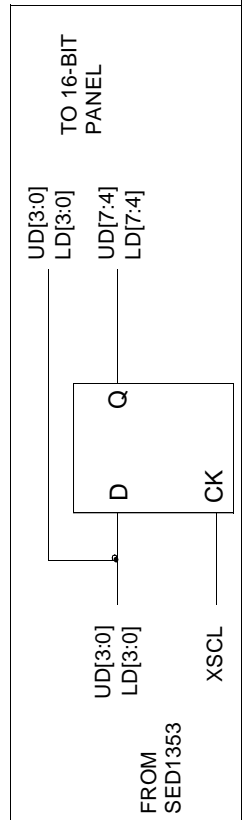

SED1353

■ PACKAGE DIMENSIONS: SED1353F0A

QFP5-100PIN-S2  
(SED1353F0A)

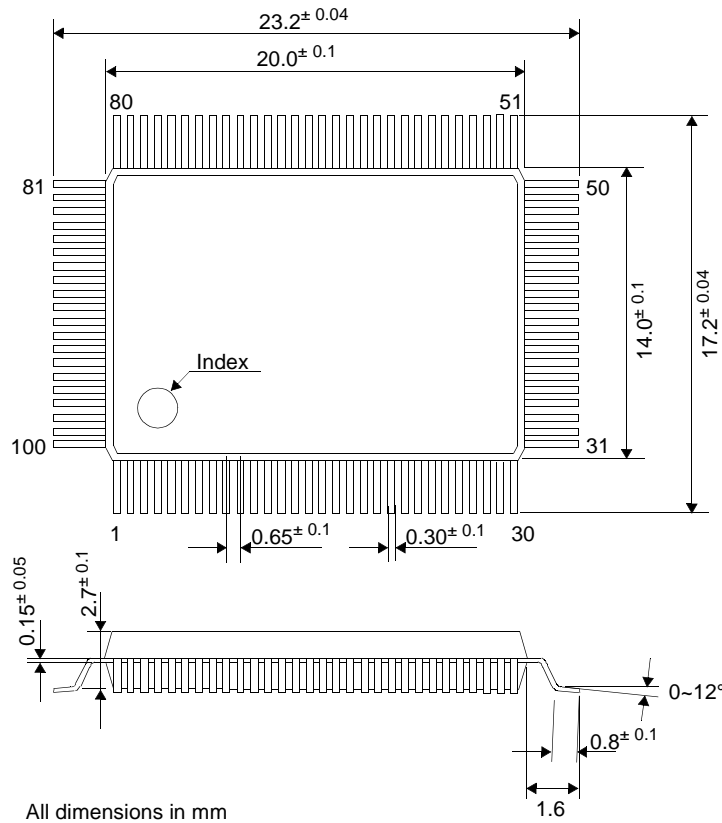

All dimensions in mm

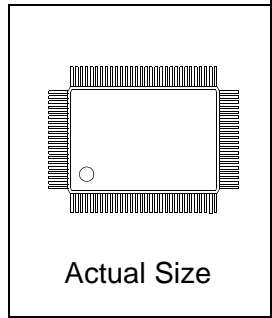

■ PACKAGE DIMENSIONS: SED1353F1A

QFP15-100PIN-STD  
(SED1353F1A)

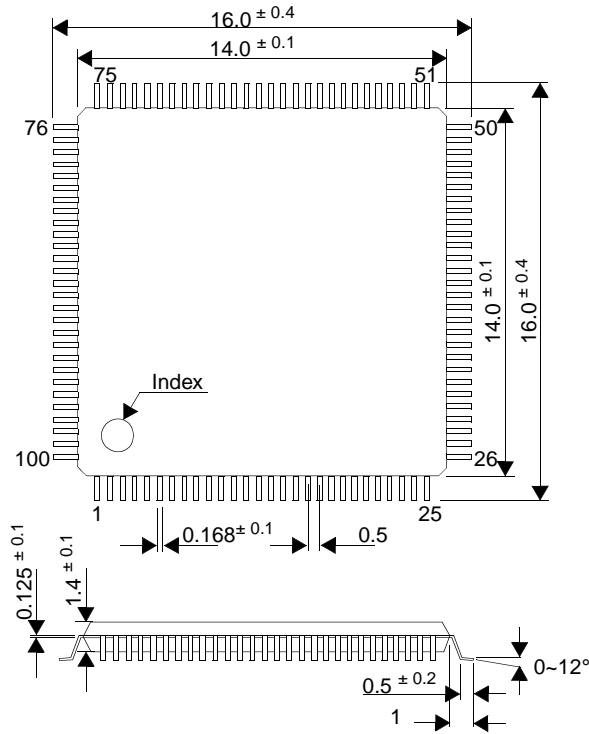

All dimensions in mm

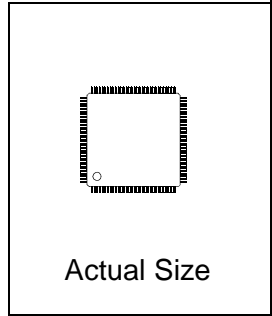

## SED1353

### ■ COMPREHENSIVE SUPPORT TOOLS

Seiko Epson Corp. provides the designer and manufacturer a complete set of resources and tools for the development of LCD Graphics Systems.

#### Documentation

- Technical Manuals
- Evaluation/Demonstration Board Manual

#### Evaluation/Demonstration Board

- Assembled and Fully Tested Graphics Evaluation/Demonstration Board
- Schematic of Evaluation/Demonstration Board
- Parts List
- Installation Guide
- CPU Independent Software Utilities
- Evaluation Software
- Windows CE Display Driver

### ■ APPLICATION ENGINEERING SUPPORT

Seiko Epson Corp. offers the following services through their Sales and Marketing Network:

- Sales Technical Support
- Customer Training

### CONTACT YOUR SALES REPRESENTATIVE FOR THESE COMPREHENSIVE DESIGN TOOLS:

- SED1353 Technical Manual
- SDU1353 Evaluation Boards
- CPU Independent Software Utilities

#### Japan

Seiko Epson Corporation  
Electronic Devices Marketing Division  
421-8, Hino, Hino-shi  
Tokyo 191-8501, Japan  
Tel: 042-587-5812  
Fax: 042-587-5564  
<http://www.epson.co.jp>

#### Hong Kong

Epson Hong Kong Ltd.  
20/F., Harbour Centre  
25 Harbour Road  
Wanchai, Hong Kong  
Tel: 2585-4600  
Fax: 2827-4346

#### North America

Epson Electronics America, Inc.  
150 River Oaks Parkway  
San Jose, CA 95134, USA  
Tel: (408) 922-0200  
Fax: (408) 922-0238  
<http://www.eea.epson.com>

#### Europe

Epson Europe Electronics GmbH  
Riesstrasse 15  
80992 Munich, Germany  
Tel: 089-14005-0  
Fax: 089-14005-110

#### Taiwan, R.O.C.

Epson Taiwan Technology  
& Trading Ltd.  
10F, No. 287  
Nanking East Road  
Sec. 3, Taipei, Taiwan, R.O.C.  
Tel: 02-2717-7360  
Fax: 02-2712-9164

#### Singapore

Epson Singapore Pte., Ltd.  
No. 1  
Temasek Avenue #36-00  
Millenia Tower  
Singapore, 039192  
Tel: 337-7911  
Fax: 334-2716

Copyright ©1997, 1998 Epson Research and Development, Inc. All rights reserved.

Information in this document is subject to change without notice. You may download and use this document, but only for your own use in evaluating Seiko Epson/EPSON products. You may not modify the document. Epson Research and Development, Inc. disclaims any representation that the contents of this document are accurate or current. The Programs/Technologies described in this document may contain material protected under U.S. and/or International Patent laws. EPSON is a registered trademark of Seiko Epson Corporation. Microsoft and Windows are registered trademarks of Microsoft Corporation.

VDC