

DATA SHEET

TDA8416

TV and VTR stereo/dual sound
processor with integrated filters and
I²C-bus control

Preliminary specification
File under Integrated Circuits, IC02

November 1989

TV and VTR stereo/dual sound processor with integrated filters and I²C-bus control

TDA8416

GENERAL DESCRIPTION

The TDA8416 is a processor of stereo/dual language signals (B/G-standard) for stereo sound television receivers and VTRs, using the switched-capacitor technique. The AF signals at the TDA8416 inputs must be “(L+R)/2” or “language A” on one channel and “R” or “language B” on the second channel (where L = left and R = right). The carrier frequency of the second channel is also modulated by an identification signal (stereo or dual sound). The device is controlled by a microcomputer via the two-line, bidirectional I²C-bus.



Features

- Use of the switched-capacitor technique for signal processing
- Small amount of peripheral components
- Integrated anti-aliasing filters
- Low distortion AF signal handling
- Integrated de-emphasis with a time constant of 50 μ s
- Two general purpose output ports
- Full ESD protection

QUICK REFERENCE DATA

PARAMETER	CONDITION	SYMBOL	MIN.	TYP.	MAX.	UNIT
Supply voltage (pin 15)		V_P	–	12	–	V
Supply current (pin 15)		I_P	–	10	–	mA
AF output signal (RMS value) (pins 11 to 14)		V_o	–	2	–	V
Weighted signal-to-noise ratio of the AF output signals (CCIR 468/3)		(S+W)/W	70	–	–	dB
Crosstalk attenuation stereo mode at	$f = 1$ kHz	α_S	40	–	–	dB
dual sound mode at	$f = 40$ Hz to 12.5 kHz	α_{DS}	70	–	–	dB
Pilot signal input sensitivity		V_i	–	2.5	–	mV
Total harmonic distortion		THD	–	0.1	–	%

PACKAGE OUTLINE

20-lead DIL; plastic (SOT146); SOT146-1; 1996 November 18.

TV and VTR stereo/dual sound processor with integrated filters and I²C-bus control

TDA8416

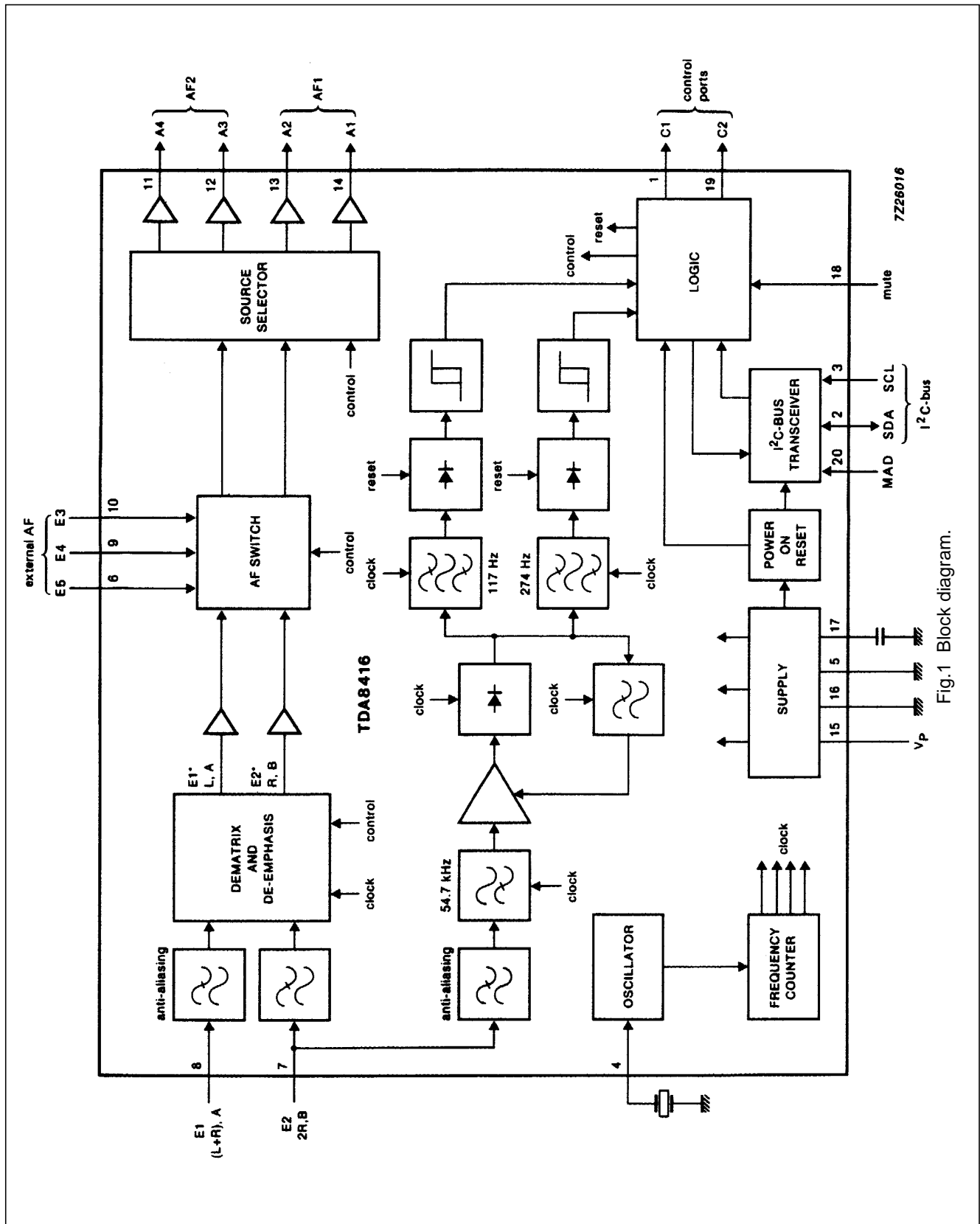

Fig.1 Block diagram.

TV and VTR stereo/dual sound processor
with integrated filters and I²C-bus control

TDA8416

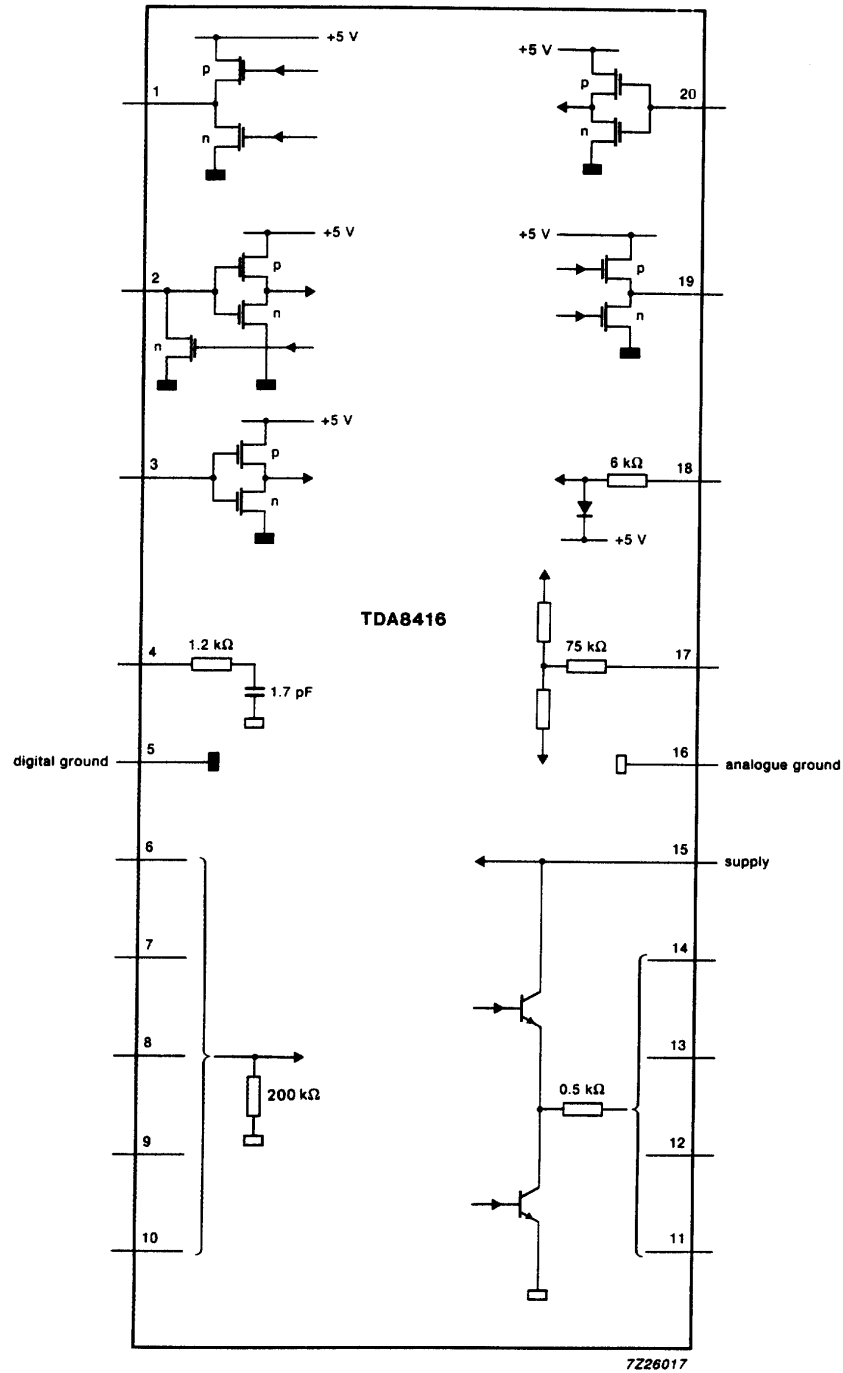

Fig.2 Input and output loading diagram.

**TV and VTR stereo/dual sound processor
with integrated filters and I²C-bus control**

TDA8416**PINNING**

- 1 Control port C1
- 2 SDA, serial data line (I²C-bus)
- 3 SCL, serial clock line (I²C-bus)
- 4 Oscillator input (or quartz)
- 5 Digital ground (0 V)
- 6 External AF input (E5)
- 7 Sound channel input AF2 (E2)
- 8 Sound channel input AF1 (E1)
- 9 External AF input (E4)
- 10 External AF input (E3)
- 11 Output A4 AF 2 output
- 12 Output A3 AF 2 output
- 13 Output A2 AF 1 output
- 14 Output A1 AF 1 output
- 15 Supply voltage V_P
- 16 Analogue ground (0 V)
- 17 Ripple rejection improvement
- 18 Mute input
- 19 Control port C2
- 20 Module address (MAD)

FUNCTIONAL DESCRIPTION**Anti-aliasing filters**

Frequency band limitation is performed by a second order Sallen and Key low-pass filter inserted in the AF signal path and the identification circuit. This limitation is necessary because of the time-discrete signal processing needed to meet the Nyquist criterium.

Identification

To enable the identification of the transmitted AF signal (mono, stereo or dual sound), the carrier frequency of the second channel (E2) is also modulated by an identification signal. The identification signal is a 54.6875 kHz pilot carrier signal which is 50% amplitude modulated by either a 117.4 Hz signal for stereo transmission or by a 274.1 Hz signal for dual sound transmission.

The identification section of the circuit consists of a 54 kHz high-pass filter followed by a gain controlled amplifier with an AM demodulator. The total gain of the high-pass filter and the amplifier is approximately 56 dB. The demodulated identification signal is filtered by the identification band-pass filters, (117.4 Hz for stereo transmission, 274.1 Hz for dual sound transmission). The output from either filter is converted to a DC signal by a peak detector and the necessary hysteresis is performed by a Schmitt-trigger. The resultant DC output signals indicate the status of the transmitter (mono, stereo or dual sound).

TV and VTR stereo/dual sound processor with integrated filters and I²C-bus control

TDA8416

De-matrix and de-emphasis

Depending on the results of the identification circuit (mono, stereo or dual sound) the AF signals at the inputs E1 and E2 are converted to the signals at E1* and E2* as listed in Table 1.

Table 1 Transmitter status ⁽¹⁾

TRANSMITTER STATUS	E1	E2	E1*	E2*
mono	0.7(L+R)	–	2(L+R)	–
stereo	0.7(L+R)	2R	4L	4R
dual sound	0.7A	B	2A	2B

Note

1. L = left channel signal;
R = right channel signal;
A = first sound channel signal;
B = second sound channel signal

This section of the circuit also performs the de-emphasis (50 μ s time constant) with a high degree of accuracy.

AF switch

The AF switch is used to switch to either the internal sound sources (E1* or E1* and E2*) or, to the external sound source (E3 and E4) and is controlled via the I²C-bus.

Source selector

The source selector is used to connect the outputs from the AF switch to the outputs A1 to A4 as illustrated by Table 5. The selector is controlled via the I²C-bus.

Muting

In this mode the AF outputs A1 to A4 are muted, and the identification circuit is deactivated (mono). The muting is active after power-on reset or as a result of user control (via the mute input and bit CR3 of the control byte of the mute and port control register; see Table 4).

Sound mute

If the switch register is set to (00) hex, (sound mute) only the AF outputs are muted, the identification circuit is still active and can be read (status register) via the I²C-bus.

Power-on reset

The following actions are carried out by the internal power-on reset when it is active:

- The AF outputs are muted
- The identification circuit is deactivated (mono)
- The control ports (C1 and C2) are set LOW
- The I²C-bus transceiver is initialized

TV and VTR stereo/dual sound processor
with integrated filters and I²C-bus control

TDA8416

When the power-on reset becomes passive the following occurs:

- The AF outputs are kept in the mute state until the contents of the switch register are changed from (00) hex via the I²C-bus
- The identification circuit is activated
- The control ports are LOW until the mute and control port register is changed (CR bits 10, 11, 20 and 21)
- The I²C-bus transceiver is activated

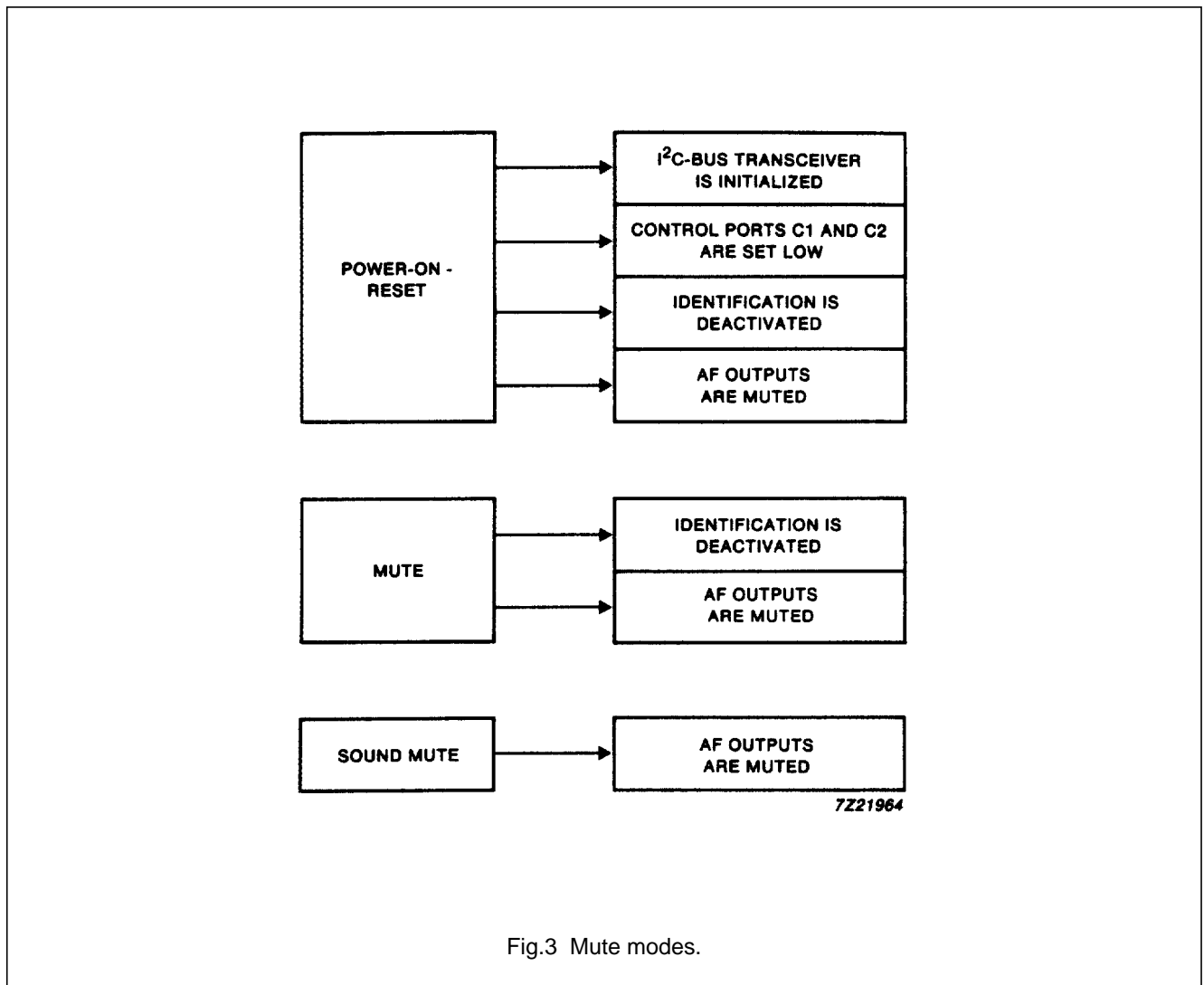

Fig.3 Mute modes.

TV and VTR stereo/dual sound processor
with integrated filters and I²C-bus control

TDA8416

Control ports

The general purpose control ports C1 and C2 can be set to LOW, HIGH or high impedance via the I²C-bus.

I²C-bus receiver and data handling

Bus specification

The TDA8416 is controlled, via the bidirectional 2-line I²C-bus, by a microcomputer. The two lines are a serial data line (SDA) and a serial clock line (SCL). Both lines must be connected to a positive supply via a pull-up resistor. Data transfer may be initiated only when the bus is not busy.

When the bus is free both lines are HIGH. The data on the SDA line must be stable during the HIGH period of the clock. The HIGH or LOW state of the data line can only change when the clock signal on the SCL line is LOW. The set up and hold times are specified in the CHARACTERISTICS.

A HIGH-to-LOW transition of the SDA line while SCL is HIGH is defined as the start condition (S). A LOW-to-HIGH transition of the SDA line while SCL is HIGH is defined as the stop condition (P). The bus receiver will be reset on the reception of a start condition. The bus is considered to be busy after the start condition. The bus is considered to be free again after a stop condition.

The I²C-BUS PROTOCOL OF THE TDA8416

The TDA8416 is controlled by a microcomputer and can be written to or read from via the I²C-bus.

The first byte is the address and determines whether the TDA8416 is to be read from (status register) or written to (switch register or mute and port control register).

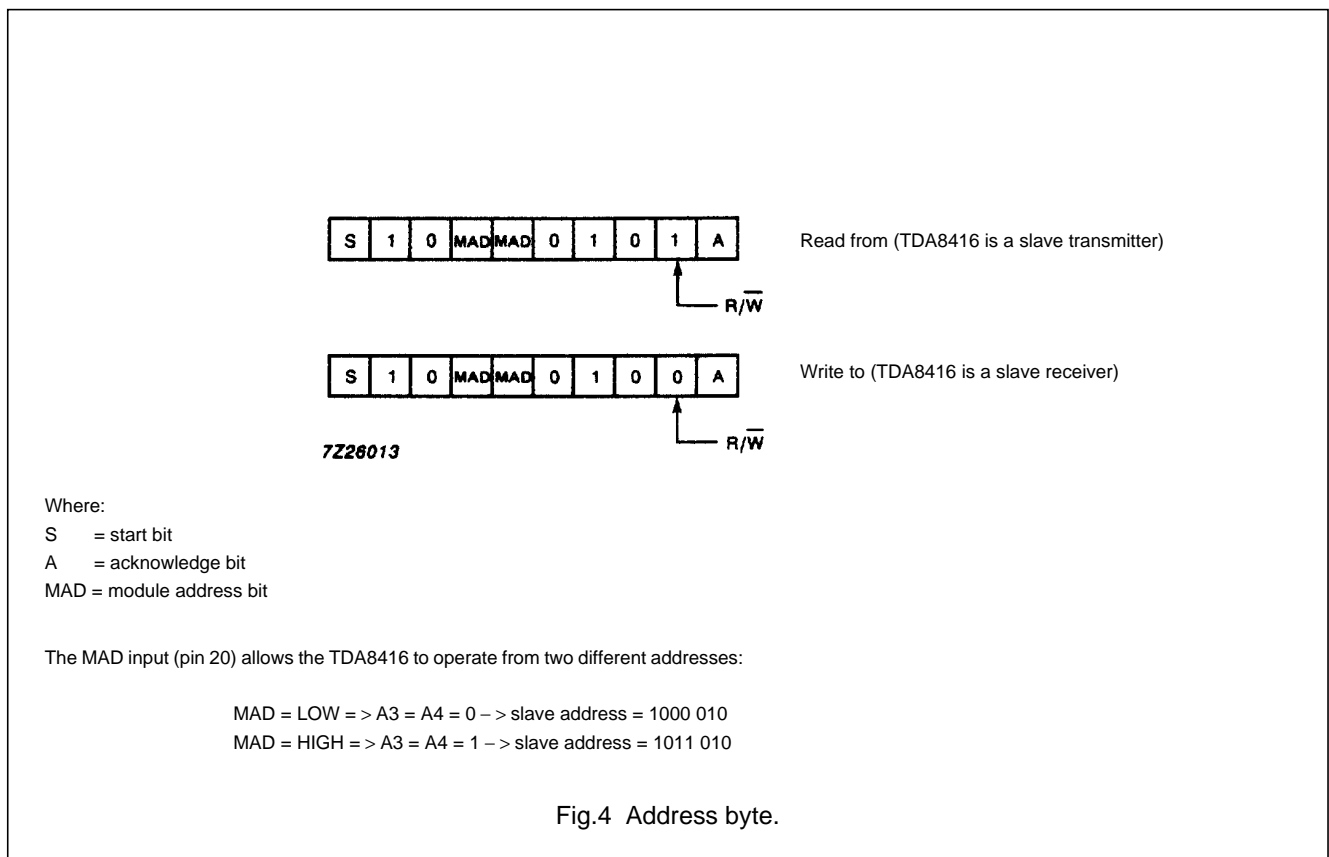

TV and VTR stereo/dual sound processor
with integrated filters and I²C-bus control

TDA8416

Reading the TDA8416

Reading the TDA8416 means reading the status register and the data stream will have the format as illustrated in Fig.5.

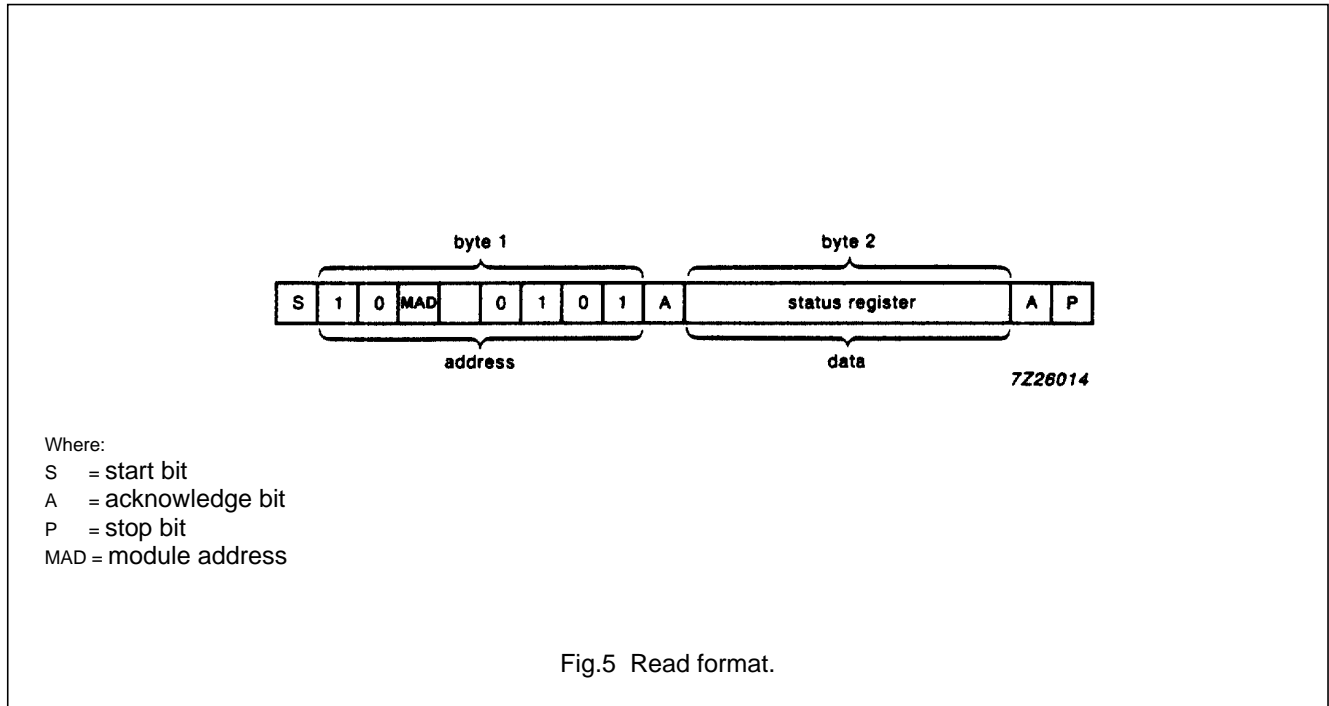

The second byte, the contents of the status register, is defined by Table 2.

Table 2 Status register (see note 1)

D7	D6	D5	D4	D3	D2	D1	D0
PONRES	ST	DS	0	0	0	0	0

Note

- PONRES = power on reset;
 1 = power on reset active after switching on or power breakdown;
 0 = after reading the status register;
 ST = stereo transmission;
 DS = dual sound transmission

The truth table for the ST and DS bits is provided by Table 3.

Table 3 Truth table for the ST and DS bits

ST	DS	DEFINITION
0	0	mono transmission
0	1	dual sound transmission
1	0	stereo transmission

TV and VTR stereo/dual sound processor
with integrated filters and I²C-bus control

TDA8416

Writing to the TDA8416

Writing to the TDA8416 means, writing to either the switch register or the mute and port control register. Which one is to be addressed is defined by the subaddress (the second byte) as illustrated by Fig.6. The third byte contains the information to be stored in the specified register.

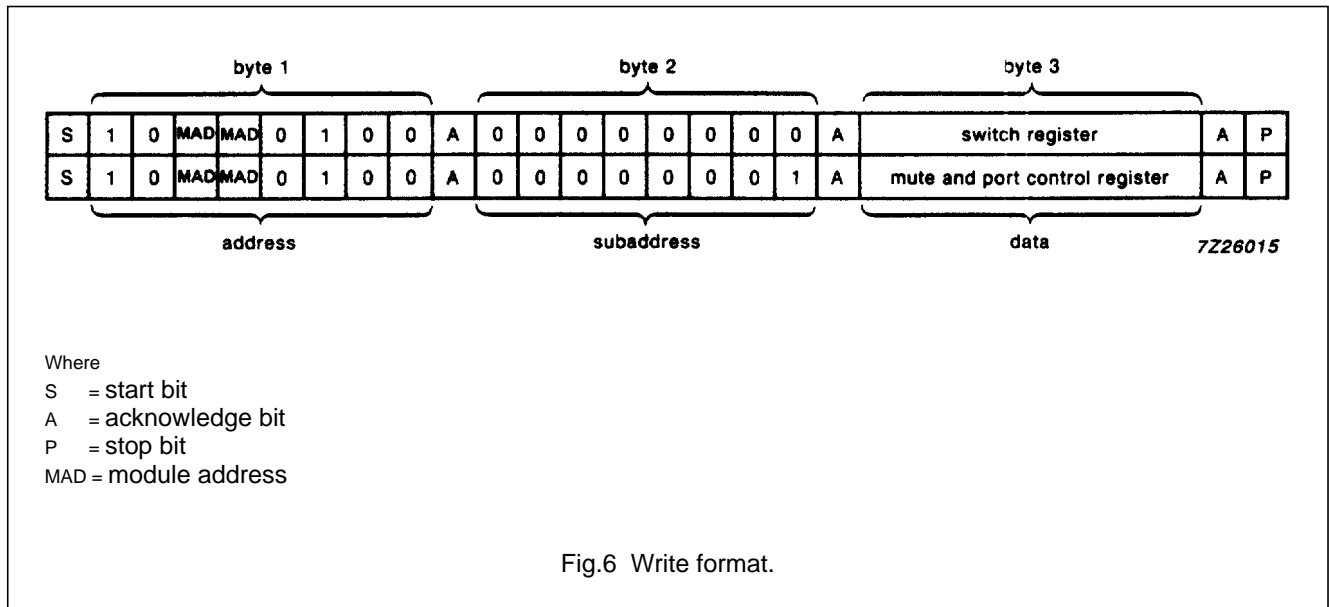

Table 4 defines the contents of the mute and port control register.

Table 4 Mute and port control register ⁽¹⁾

D7	D6	D5	D4 CR3	D3 CR21	D2 CR20	D1 CR11	D0 CR10	DEFINITION
X	X	X				0	0	control port C1 = LOW
X	X	X				0	1	control port C1 = HIGH
X	X	X				1	X	control port C1 = high impedance
X	X	X		0	0			control port C2 = LOW
X	X	X		0	1			control port C2 = HIGH
X	X	X		1	X			control port C2 = high impedance
X	X	X	0					mute is active when pin 18 is LOW (default)
X	X	X	1					mute is active when pin 18 is HIGH

Note

- 1. X = don't care

TV and VTR stereo/dual sound processor with integrated filters and I²C-bus control

TDA8416

Table 5 defines the contents of the switch register.

Table 5 Switch register ⁽¹⁾

SWITCH REGISTER		INPUT					OUTPUT				D7	D6	D5	D4	D3	D2	D1	D0	(HEX)	
		E1	E2	E3	E4	E5	A1	A2	A3	A4										
sound mute	–	–	–	–	–	–	no signal				0	0	0	0	0	0	0	0	0	(00)
mono	M	M	M	–	–	–	M	M	M	M	0	0	0	1	0	0	0	0	(10)	
	St	L*	R	–	–	–	L*	L*	L*	L*	0	0	0	1	0	0	0	0	(10)	
stereo	St	L*	R	–	–	–	L	R	L	R	0	0	1	0	1	0	1	0	(2A)	
	DS	A	B	–	–	–	A	A	A	A	0	0	0	1	0	0	0	0	(10)	
sound A	DS	A	B	–	–	–	B	B	B	B	0	0	0	1	1	1	1	1	(1F)	
dual sound	DS	A	B	–	–	–	A	A	B	B	0	0	0	1	1	1	0	0	(1C)	
	DS	A	B	–	–	–	B	B	A	A	0	0	0	1	0	0	1	1	(13)	
dual sound mix	DS	A	B	–	–	–	A	B	A	A	0	0	0	1	0	0	1	0	(12)	
	DS	A	B	–	–	–	A	A	A	B	0	0	0	1	1	0	0	0	(18)	
external	DS	A	B	–	–	–	A	B	A	B	0	0	0	1	1	0	1	0	(1A)	
	DS	A	B	–	–	–	B	B	A	B	0	0	0	1	1	0	1	1	(1B)	
–	–	–	–	E3	E4	–	A	B	B	B	0	0	0	1	1	1	1	0	(1E)	
–	–	–	–	E3	E4	–	E3	E3	E3	E3	0	1	1	1	0	0	0	0	(70)	
–	–	–	–	E3	E4	–	E4	E4	E4	E4	0	1	1	1	1	1	1	1	(7F)	
–	–	–	–	E3	E4	–	E3	E4	E3	E4	0	1	1	1	1	0	1	0	(7A)	
–	–	–	–	E3	E4	–	E4	E4	E3	E3	0	1	1	1	0	0	1	1	(73)	
–	–	–	–	E3	E4	–	E3	E3	E4	E4	0	1	1	1	1	1	0	0	(7C)	
–	–	–	–	E3	E4	–	E3	E4	E3	E3	0	1	1	1	0	0	1	0	(72)	
–	–	–	–	E3	E4	–	E3	E3	E3	E4	0	1	1	1	1	0	0	0	(78)	
–	–	–	–	E3	E4	–	E4	E4	E3	E4	0	1	1	1	1	0	1	1	(7B)	
–	–	–	–	E3	E4	–	E3	E4	E4	E4	0	1	1	1	1	1	1	0	(7E)	
–	–	–	–	–	E5	–	E5	E5	E5	E5	1	0	0	0	0	0	0	0	(80)	

Note

1. M = mono;
St = stereo;
DS = dual sound;
R = right;
L = left;
L* = (L + R)/2;
A = sound A;
B = sound B

TV and VTR stereo/dual sound processor
with integrated filters and I²C-bus control

TDA8416

RATINGS

Limiting values in accordance with Absolute Maximum System (IEC 134)

PARAMETER	SYMBOL	MIN.	TYP.	MAX.	UNIT
Supply voltage ⁽¹⁾	$V_P = V_{15-16}$	–	–	13.2	V
Output current					
pins 11, 12, 13, 14	I_O	–	–	10	mA
pins 1 and 19 (sink)	I_O	–	–	7	mA
(source)	$-I_O$	–	–	3	mA
Input voltage (not pin 18)	V_I	0	–	V_P	V
Input voltage pin 18	$V_I = V_{18-16}$	–	–	7	V
Output voltage	V_O	0	–	V_P	V
Total power dissipation	P_{tot}	–	–	1	W
ESD protection (each pin) (0 Ω /200 pF)	V_{es}	500	–	–	V
Operating ambient temperature range	T_{amb}	0	–	+ 70	°C
Storage temperature range	T_{stg}	–40	–	+ 150	°C

Note

1. Supply voltage may be applied only when both pins 5 and 15 are connected to ground.

TV and VTR stereo/dual sound processor with integrated filters and I²C-bus control

TDA8416

CHARACTERISTICS

$V_P = 12\text{ V}$; $T_{\text{amb}} = 25\text{ °C}$. Measurement conditions (see Fig.7): reference level is 1 V (RMS); test frequency = 3.183 kHz; noise measurement in accordance with DIN 45405, CCIR 468-3; oscillator frequency = 10 MHz; pre-emphasis time constant = 50 μs .

PARAMETER	CONDITIONS	SYMBOL	MIN.	TYP.	MAX.	UNIT
Supplies						
Supply voltage		$V_P = V_{15-16}$	10.8	12	13.2	V
Supply current		$I_P = I_{15}$	–	10	–	mA
DC levels						
pins 6 - 14 and 17		V_{n-16}	–	3.25	–	V
pin 4		V_{4-5}	–	2	–	V
Bus transceiver						
Clock frequency (I ² C-bus)	note 1	f_{CLK}	0.7	–	100	kHz
Clock SCL (pin 3)						
Input voltage LOW		V_{IL}	–0.3	–	1.5	V
Input voltage HIGH		V_{IH}	3	–	5	V
Timing LOW period		t_{LOW}	4.7	–	–	μs
Timing HIGH period		t_{HIGH}	4	–	–	μs
Rise time		t_r	–	–	1	μs
Fall time		t_f	–	–	0.3	μs
Input current LOW		$-I_{\text{IL}}$	–	–	10	μA
Input current HIGH		I_{IH}	–	–	10	μA
Data SDA (pin 2)						
Input voltage LOW		V_{IL}	–0.3	–	1.5	V
Input voltage HIGH		V_{IH}	3	–	5	V
Rise time		t_r	–	–	1	μs
Fall time		t_f	–	–	0.3	μs
Data set-up time		$t_{\text{SU; DAT}}$	0.25	–	–	μs
Input current LOW		$-I_{\text{IL}}$	–	–	10	μA
Input current HIGH		I_{IH}	–	–	10	μA
Output current LOW		I_{OL}	3	–	–	mA
MAD (pin 20)						
Input voltage LOW		V_{20-5}	–	–	2.0	V
Input voltage HIGH		V_{20-5}	3.0	–	–	V

**TV and VTR stereo/dual sound processor
with integrated filters and I²C-bus control**
TDA8416

PARAMETER	CONDITIONS	SYMBOL	MIN.	TYP.	MAX.	UNIT
Mute port (pin 18)						
Input voltage LOW	note 2	V_{IL}	-0.3	-	1.5	V
Input voltage HIGH	note 2	V_{IH}	3	-	5	V
Control ports (pins 1 and 19)						
Output voltage LOW	note 3	V_{OL}	-	-	0.5	V
Output voltage HIGH	note 3	V_{OH}	4.5	-	5	V
Output impedance	3-state	Z_O	1	-	-	M Ω
Output current LOW		I_{OL}	1	-	-	mA
Output current HIGH		$-I_{OH}$	1	-	-	mA
AF stages and identification (pins 7 to 14)						
Input impedance (pins 7 to 10)		Z_i	150	200	-	k Ω
Input voltage E1		V_I	-	-	0.7	V
Input voltage E2		V_I	-	-	1	V
Input voltage E2 for identification active (RMS value)	note 4	V_i	2.5	-	-	mV
Voltage gain 7-15/output	note 5	G_v	5.9	6	6.1	dB
Voltage gain 8-15/output	note 5	G_v	8.9	9	9.1	dB
Voltage gain 6, 9, 10-15/output		G_v	-0.1	0	0.1	dB
Crosstalk attenuation dual mode	notes 6 to 8	α_{ds}	70	75	-	dB
stereo mode		α_s	30	50	-	dB
Output impedance (pins 11 to 14)		Z_O	400	500	600	Ω
De-emphasis time constant	note 9		49.5	50	50.5	μ s
Frequency response	note 6	Δf	-1	-	1	dB
Total harmonic distortion	note 10	THD	-	-	0.2	%
Capacitive load (pins 11 to 14)		C_L	-	-	1.5	nF
Output signal (RMS value) (pins 11 to 14)	THD \leq 0.2%	V_O	-	-	2	V

TV and VTR stereo/dual sound processor
with integrated filters and I²C-bus control

TDA8416

PARAMETER	CONDITIONS	SYMBOL	MIN.	TYP.	MAX.	UNIT
Ripple rejection	note 11	RR	50	66	–	dB
Noise from I ² C-bus		NR	–	–	–80	dB
Signal-to-noise ratio		(S+W)/W	70	–	–	dBV CCIR
Signal suppression during mute	note 6	SS	70	75	–	dB
Change of output DC voltage level between any two modes			–	–	30	mV
Oscillator						
Oscillator frequency		f _{osc}	–	10	–	MHz
External oscillator signal (RMS value)		V ₄₋₅	1.7	–	–	V
Quartz series resistor		R1	–	–	100	Ω
Impedance		Z _i	–	–1.2 + j9.3	–	kΩ
Capacitance		C _{OSC}	–	1.7	–	pF

Notes to the characteristics

1. Full specification of I²C-bus will be supplied on request.
2. Programmable mute state. If the CR3 bit of the mute and port control register is LOW, the mute is active LOW; if it is HIGH, the mute input is active HIGH.
3. Output current I_O ≈ 1 mA.
4. Unmodulated.
5. f = 400 Hz; R_L = 1 MΩ.
6. 40 Hz ≤ f ≤ 15 kHz.
7. In dual mode: A(B)-signal into B(A)-channel.
In stereo mode: R-signal into left, L-signal = 0, reference is 1 V RMS.
8. Source impedance |Z_S| < 1 kΩ.
9. Equivalent to an output level of –3 dB at f = 3.183 kHz.
10. V_O = 1 V RMS; f = 1 kHz.
11. Test circuit see Fig.7.

TV and VTR stereo/dual sound processor
with integrated filters and I²C-bus control

TDA8416

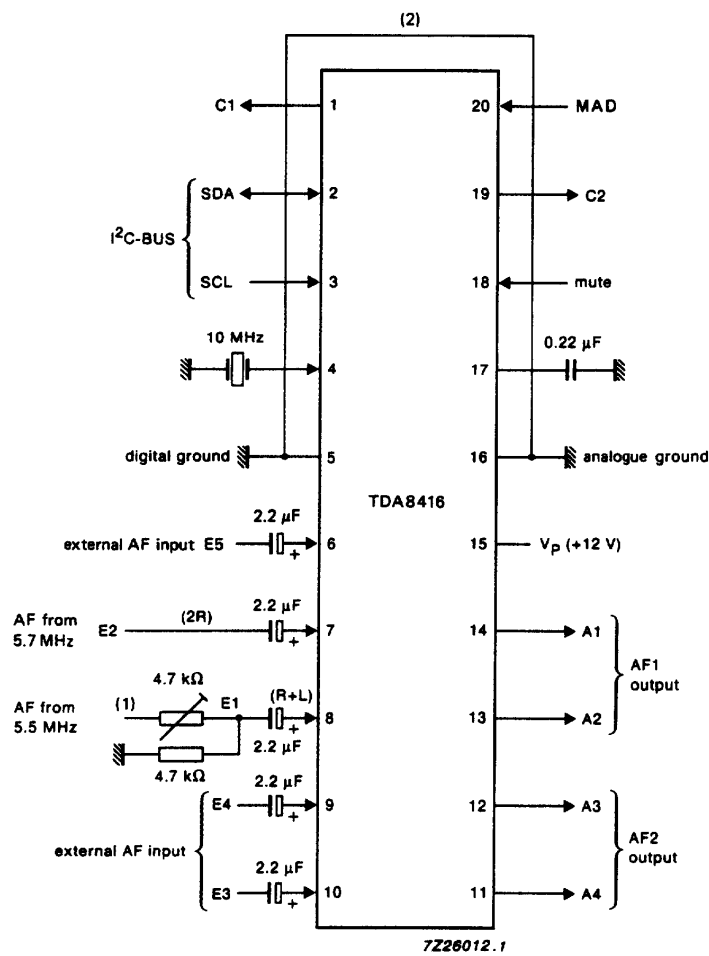

- (1) This potentiometer has to be adjusted to achieve the best stereo separation.
- (2) Direct connection between pins 5 and 16 is achieved.

Fig.7 Application and test circuit.

TV and VTR stereo/dual sound processor
with integrated filters and I²C-bus control

TDA8416

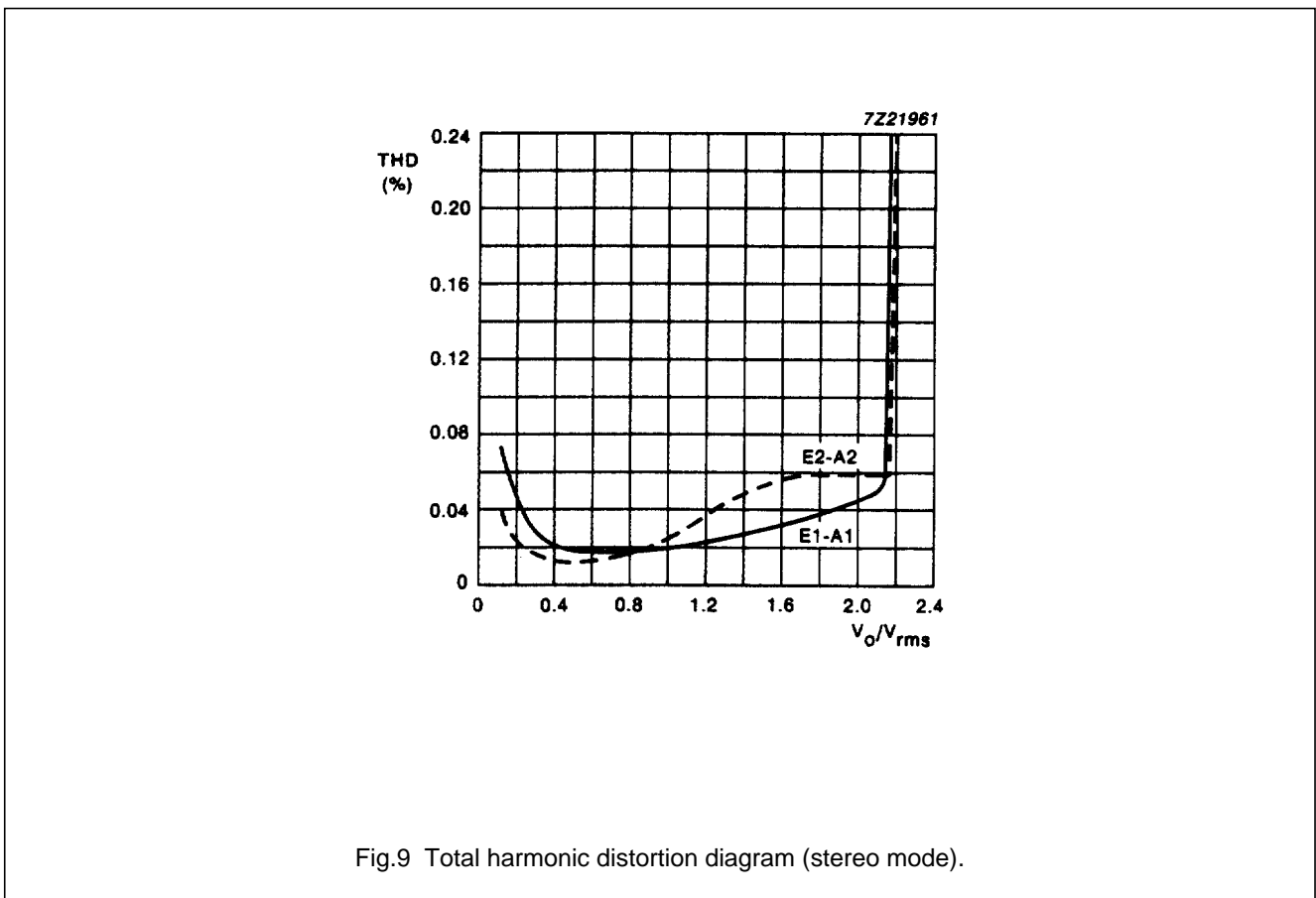
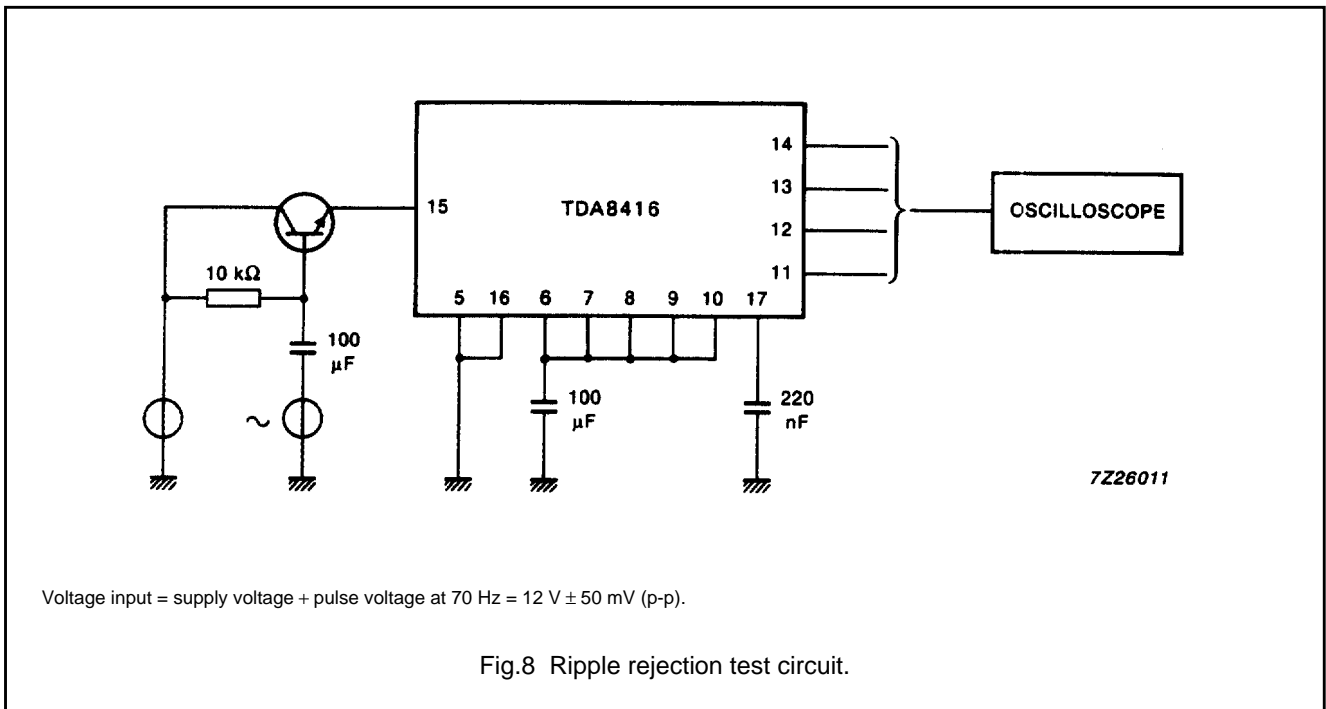

TV and VTR stereo/dual sound processor
with integrated filters and I²C-bus control

TDA8416

PACKAGE OUTLINE

DIP20: plastic dual in-line package; 20 leads (300 mil)

SOT146-1

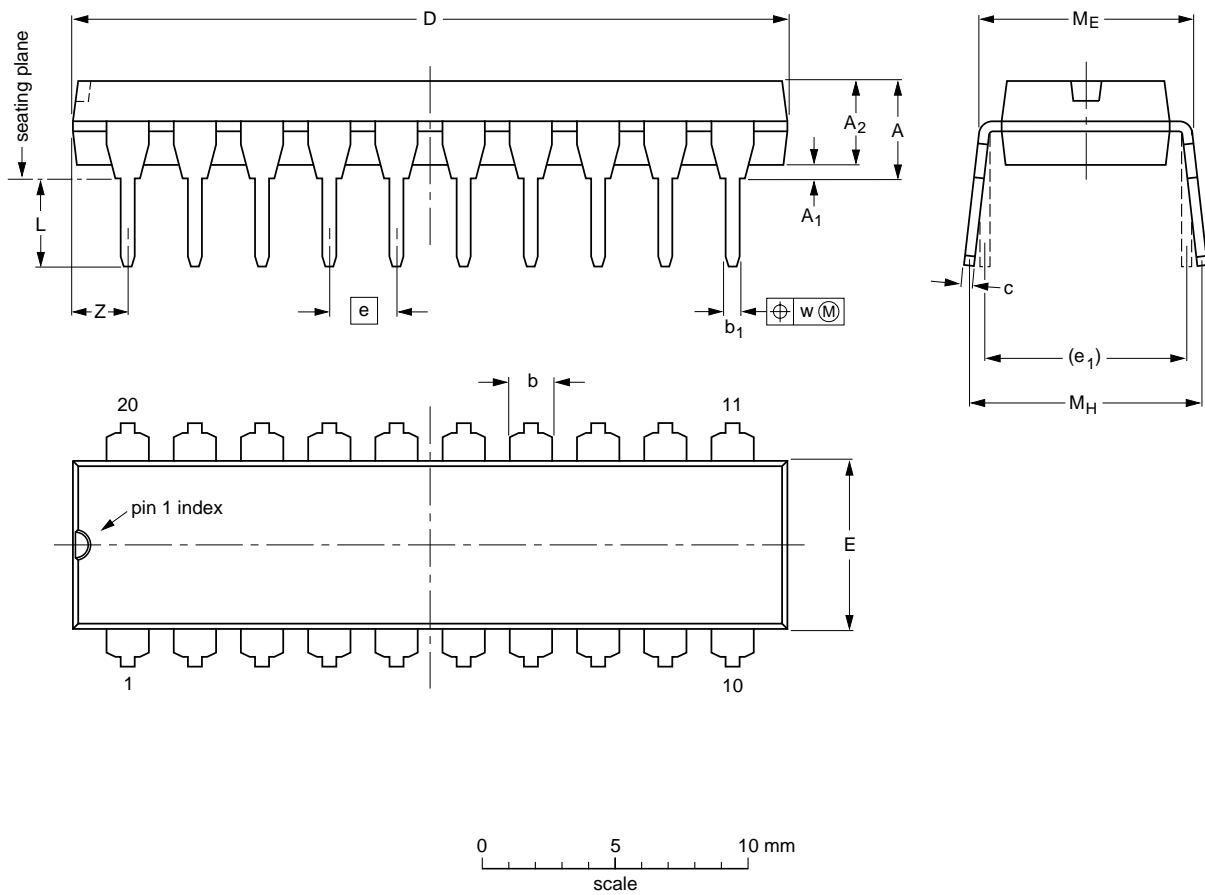

DIMENSIONS (inch dimensions are derived from the original mm dimensions)

UNIT	A max.	A ₁ min.	A ₂ max.	b	b ₁	c	D ⁽¹⁾	E ⁽¹⁾	e	e ₁	L	M _E	M _H	w	Z ⁽¹⁾ max.
mm	4.2	0.51	3.2	1.73 1.30	0.53 0.38	0.36 0.23	26.92 26.54	6.40 6.22	2.54	7.62	3.60 3.05	8.25 7.80	10.0 8.3	0.254	2.0
inches	0.17	0.020	0.13	0.068 0.051	0.021 0.015	0.014 0.009	1.060 1.045	0.25 0.24	0.10	0.30	0.14 0.12	0.32 0.31	0.39 0.33	0.01	0.078

Note

1. Plastic or metal protrusions of 0.25 mm maximum per side are not included.

OUTLINE VERSION	REFERENCES				EUROPEAN PROJECTION	ISSUE DATE
	IEC	JEDEC	EIAJ			
SOT146-1			SC603			92-11-17 95-05-24

TV and VTR stereo/dual sound processor with integrated filters and I²C-bus control

TDA8416

SOLDERING

Introduction

There is no soldering method that is ideal for all IC packages. Wave soldering is often preferred when through-hole and surface mounted components are mixed on one printed-circuit board. However, wave soldering is not always suitable for surface mounted ICs, or for printed-circuits with high population densities. In these situations reflow soldering is often used.

This text gives a very brief insight to a complex technology. A more in-depth account of soldering ICs can be found in our "IC Package Databook" (order code 9398 652 90011).

Soldering by dipping or by wave

The maximum permissible temperature of the solder is 260 °C; solder at this temperature must not be in contact

with the joint for more than 5 seconds. The total contact time of successive solder waves must not exceed 5 seconds.

The device may be mounted up to the seating plane, but the temperature of the plastic body must not exceed the specified maximum storage temperature ($T_{stg\ max}$). If the printed-circuit board has been pre-heated, forced cooling may be necessary immediately after soldering to keep the temperature within the permissible limit.

Repairing soldered joints

Apply a low voltage soldering iron (less than 24 V) to the lead(s) of the package, below the seating plane or not more than 2 mm above it. If the temperature of the soldering iron bit is less than 300 °C it may remain in contact for up to 10 seconds. If the bit temperature is between 300 and 400 °C, contact may be up to 5 seconds.

DEFINITIONS

Data sheet status	
Objective specification	This data sheet contains target or goal specifications for product development.
Preliminary specification	This data sheet contains preliminary data; supplementary data may be published later.
Product specification	This data sheet contains final product specifications.
Limiting values	
Limiting values given are in accordance with the Absolute Maximum Rating System (IEC 134). Stress above one or more of the limiting values may cause permanent damage to the device. These are stress ratings only and operation of the device at these or at any other conditions above those given in the Characteristics sections of the specification is not implied. Exposure to limiting values for extended periods may affect device reliability.	
Application information	
Where application information is given, it is advisory and does not form part of the specification.	

LIFE SUPPORT APPLICATIONS

These products are not designed for use in life support appliances, devices, or systems where malfunction of these products can reasonably be expected to result in personal injury. Philips customers using or selling these products for use in such applications do so at their own risk and agree to fully indemnify Philips for any damages resulting from such improper use or sale.

PURCHASE OF PHILIPS I²C COMPONENTS



Purchase of Philips I²C components conveys a license under the Philips' I²C patent to use the components in the I²C system provided the system conforms to the I²C specification defined by Philips. This specification can be ordered using the code 9398 393 40011.