

V54C365324V	-5	-55	-6	-7	-8	Unit
Clock Frequency (t_{CK})	200	183	166	143	125	MHz
CAS Latency	3	3	3	3	3	clocks
Cycle Time (t_{CK})	5	5.5	6	7	8	ns
Access Time (t_{AC})	5	5.5	6	6	6	ns

Features

- JEDEC Standard 3.3V Power Supply
- The V54C365324V is ideally suited for high performance graphics peripheral applications
- Single Pulsed \overline{RAS} Interface
- Programmable \overline{CAS} Latency: 2, 3
- All Inputs are sampled at the positive going edge of clock
- Programmable Wrap Sequence: Sequential or Interleave
- Programmable Burst Length: 1, 2, 4, 8 and Full Page for Sequential and 1, 2, 4, 8 for Interleave
- DQM 0-3 for Byte Masking
- Auto & Self Refresh
- 2K Refresh Cycles/32 ms
- Burst Read with Single Write Operation

Description

The V54C365324V is a 67,108, 864 bits synchronous high data rate DRAM organized as 4 x 524,288 words by 32 bits. The device is designed to comply with JEDEC standards set for synchronous DRAM products, both electrically and mechanically. Synchronous design allows precise cycle control with the system clock. The CAS latency, burst length and burst sequence must be programmed into device prior to access operation.

PIN CONFIGURATION

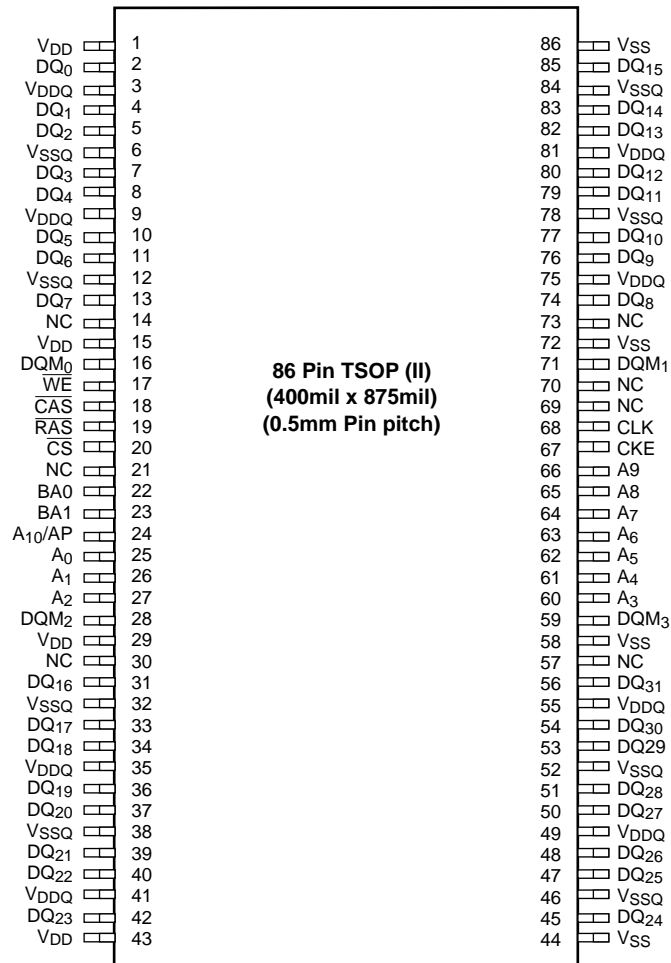

Block Diagram

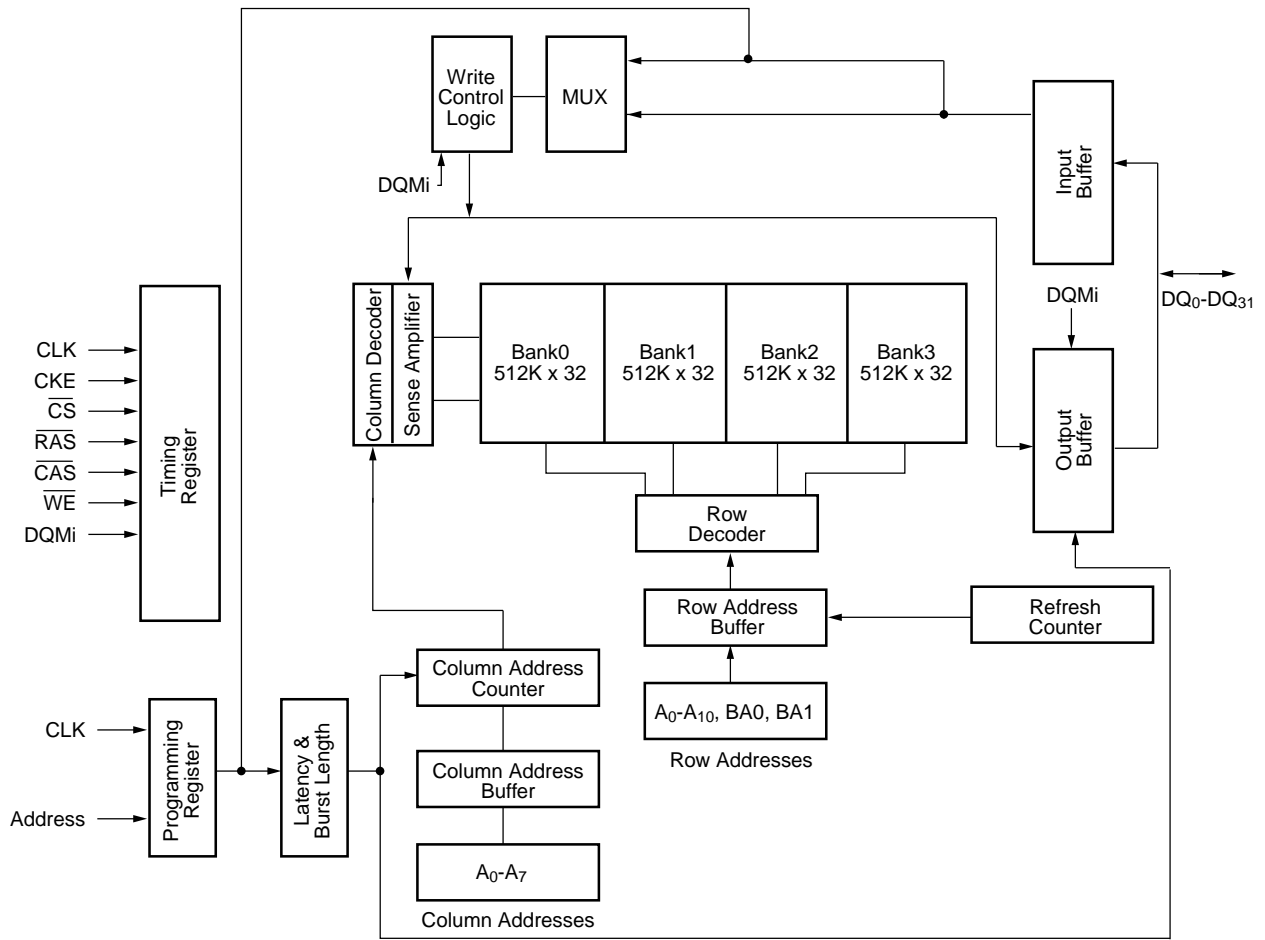

Signal Pin Description

Pin	Name	Input Function
CLK	Clock Input	System clock input. Active on the positive rising edge to sample all inputs
CKE	Clock Enable	Activates the CLK signal when high and deactivates the CLK when low. CKE low initiates the power down mode, suspend mode, or the self refresh mode
\overline{CS}	Chip Select	Disables or enables device operation by masking or enabling all inputs except CLK, CKE and DQMi
\overline{RAS}	Row Address Strobe	Latches row addresses on the positive edge of CLK with \overline{RAS} low. Enables row access & precharge
\overline{CAS}	Column Address Strobe	Latches column addresses on the positive edge of CLK with \overline{CAS} low. Enables column access
\overline{WE}	Write Enable	Enables write operation
A ₀ -A ₁₀	Address	During a bank activate command, A ₀ -A ₁₀ defines the row address. During a read or write command, A ₀ -A ₇ defines the column address. In addition to the column address A ₁₀ is used to invoke auto precharge BA define the bank to be precharged. A ₁₀ is low, auto precharge is disabled during a precharge cycle, If A ₁₀ is high, all bank will be precharged, if A ₁₀ is low, the BA ₀ , BA ₁ is used to decide which bank to precharge
BA ₀ , BA ₁	Bank Select	Selects which bank to activate.
DQ ₀ -DQ ₃₁	Data Input/Output	Data inputs/output are multiplexed on the same pins
DQMi	Data Input/Output Mask	Makes data output Hi-Z. Blocks data input when DQM is active
VDD/VSS	Power Supply/Ground	Power Supply. +3.3V ± 0.3V/ground
VDDQ/VSSQ	Data Output Power/Ground	Provides isolated power/ground to DQs for improved noise immunity
NC	No Connection	

Address Input for Mode Set (Mode Register Operation)

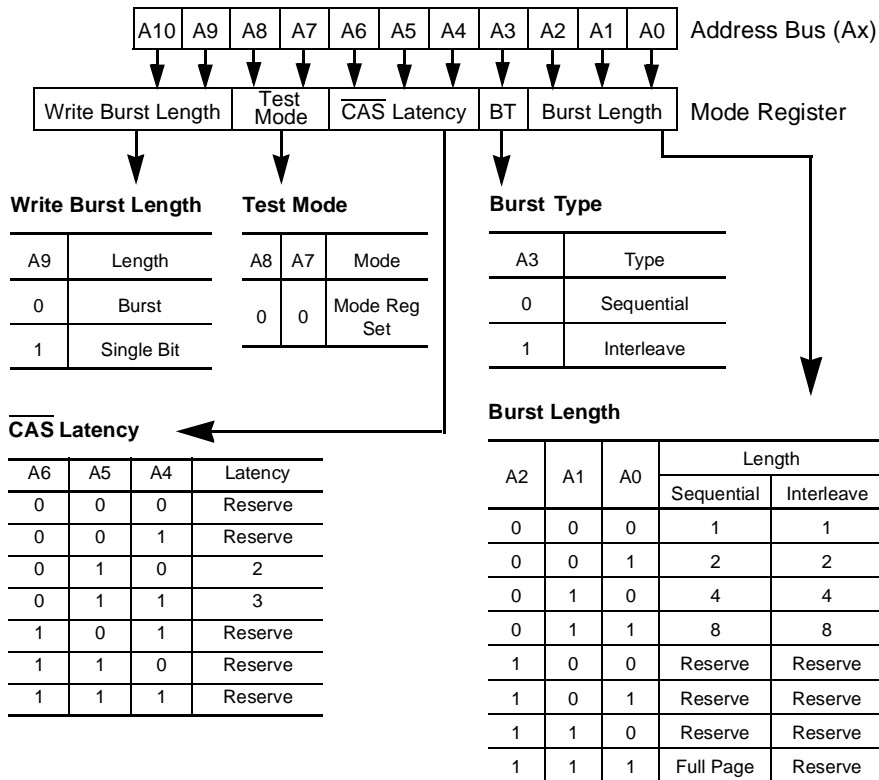

Power On and Initialization

The default power on state of the mode register is supplier specific and may be undefined. The following power on and initialization sequence guarantees the device is preconditioned to each users specific needs. Like a conventional DRAM, the Synchronous DRAM must be powered up and initialized in a predefined manner. During power on, all VCC and VCCQ pins must be built up simultaneously to the specified voltage when the input signals are held in the "NOP" state. The power on voltage must not exceed VCC+0.3V on any of the input pins or VCC supplies. The CLK signal must be started at the same time. After power on, an initial pause of 200 μs is required followed by a precharge of both banks using the precharge command. To prevent data contention on the DQ bus during power on, it is required that the DQM and CKE pins be held high during the initial pause period. Once all banks have been precharged, the Mode Register Set Command must be issued to initialize the Mode Register. A minimum of eight Auto Refresh cycles (CBR) are also required. These may be done before or after programming the Mode Register. Failure to follow these steps may lead to unpredictable start-up modes.

Programming the Mode Register

The Mode register designates the operation mode at the read or write cycle. This register is divided into 4 fields. A Burst Length Field to set the length of the burst, an Addressing Selection bit to program the column access sequence in a burst cycle (interleaved or sequential), a CAS Latency Field to set the access time at clock cycle and a Operation mode field to differentiate between normal operation (Burst read and burst Write) and a special Burst Read and Single Write mode. The mode set operation must be done before any activate command after the initial power up. Any content of the mode register can be altered by re-executing the mode set command. All banks must be in pre-charged state and CKE must be high at least one clock before the mode set operation. After the mode register is set, a Standby or NOP command is required. Low signals of RAS, CAS, and WE at the positive edge of the clock activate the mode set operation. Address input data at this timing defines parameters to be set as shown in the previous table.

Read and Write Operation

When \overline{RAS} is low and both \overline{CAS} and \overline{WE} are high at the positive edge of the clock, a RAS cycle starts. According to address data, a word line of the selected bank is activated and all of sense amplifiers associated to the wordline are set. A \overline{CAS} cycle is triggered by setting \overline{RAS} high and \overline{CAS} low at a clock timing after a necessary delay, t_{RCD} , from the \overline{RAS} timing. \overline{WE} is used to define either a read ($\overline{WE} = H$) or a write ($\overline{WE} = L$) at this stage.

SDRAM provides a wide variety of fast access modes. In a single CAS cycle, serial data read or write operations are allowed at up to a 200 MHz data rate. The numbers of serial data bits are the burst length programmed at the mode set operation, i.e., one of 1, 2, 4, 8 and full page. Column addresses are segmented by the burst length and serial data accesses are done within this boundary. The first column address to be accessed is supplied at the CAS timing and the subsequent addresses are generated automatically by the programmed burst length and its sequence. For example, in a burst length of 8 with interleave sequence, if the first address is '2', then the rest of the burst sequence is 3, 0, 1, 6, 7, 4, and 5.

Full page burst operation is only possible using the sequential burst type and page length is a function of the I/O organisation and column addressing. Full page burst operation do not self terminate once the burst length has been reached. In other words, unlike burst length of 2, 3 or 8, full page burst continues until it is terminated using another command.

Similar to the page mode of conventional DRAM's, burst read or write accesses on any column address are possible once the RAS cycle latches the sense amplifiers. The maximum t_{RAS} or the refresh interval time limits the number of random column accesses. A new burst access can be done even before the previous burst ends. The interrupt operation at every clock cycles is supported. When the previous burst is interrupted, the remaining addresses are overridden by the new address with the full burst length. An interrupt which accompanies with an operation change from a read to a write is possible by exploiting DQM to avoid bus contention.

When two or more banks are activated sequentially, interleaved bank read or write operations are possible. With the programmed burst length, alternate access and precharge operations on two or more banks can realize fast serial data access modes among many different pages. Once two or more banks are activated, column to column interleave operation can be done between different pages.

Refresh Mode

SDRAM has two refresh modes, Auto Refresh and Self Refresh. Auto Refresh is similar to the \overline{CAS} -before- \overline{RAS} refresh of conventional DRAMs. All of banks must be precharged before applying any refresh mode. An on-chip address counter increments the word and the bank addresses and no bank information is required for both refresh modes.

Burst Length and Sequence:

Burst Length	Starting Address (A2 A1 A0)	Sequential Burst Addressing (decimal)	Interleave Burst Addressing (decimal)
2	xx0	0, 1	0, 1
	xx1	1, 0	1, 0
4	x00	0, 1, 2, 3	0, 1, 2, 3
	x01	1, 2, 3, 0	1, 0, 3, 2
	x10	2, 3, 0, 1	2, 3, 0, 1
	x11	3, 0, 1, 2	3, 2, 1, 0
8	000	0 1 2 3 4 5 6 7	0 1 2 3 4 5 6 7
	001	1 2 3 4 5 6 7 0	1 0 3 2 5 4 7 6
	010	2 3 4 5 6 7 0 1	2 3 0 1 6 7 4 5
	011	3 4 5 6 7 0 1 2	3 2 1 0 7 6 5 4
	100	4 5 6 7 0 1 2 3	4 5 6 7 0 1 2 3
	101	5 6 7 0 1 2 3 4	5 4 7 6 1 0 3 2
	110	6 7 0 1 2 3 4 5	6 7 4 5 2 3 0 1
	111	7 0 1 2 3 4 5 6	7 6 5 4 3 2 1 0
Full Page	nnn	Cn, Cn+1, Cn+2,.....	not supported

The chip enters the Auto Refresh mode, when $\overline{\text{RAS}}$ and $\overline{\text{CAS}}$ are held low and CKE and $\overline{\text{WE}}$ are held high at a clock timing. The mode restores word line after the refresh and no external precharge command is necessary. A minimum tRC time is required between two automatic refreshes in a burst refresh mode. The same rule applies to any access command after the automatic refresh operation.

The chip has an on-chip timer and the Self Refresh mode is available. It enters the mode when $\overline{\text{RAS}}$, $\overline{\text{CAS}}$, and CKE are low and $\overline{\text{WE}}$ is high at a clock timing. All of external control signals including the clock are disabled. Returning CKE to high enables the clock and initiates the refresh exit operation. After the exit command, at least one tRC delay is required prior to any access command.

DQM Function

DQM has two functions for data I/O read and write operations. During reads, when it turns to "high" at a clock timing, data outputs are disabled and become high impedance after two clock delay (DQM Data Disable Latency t_{DQZ}). It also provides a data mask function for writes. When DQM is activated, the write operation at the next clock is prohibited (DQM Write Mask Latency t_{DQW} = zero clocks). DQM is used for device selection, byte selection and bus control in a memory system. DQM0 controls DQ0 to DQ7, DQM1 controls DQ8 to DQ15, DQM2 controls DQ16 to DQ23, DQM3 controls DQ24 to DQ31.

Suspend Mode

During normal access mode, CKE is held high enabling the clock. When CKE is low, it freezes the internal clock and extends data read and write operations. One clock delay is required for mode entry and exit (Clock Suspend Latency t_{CSL}).

Power Down

In order to reduce standby power consumption, a power down mode is available. All banks must be precharged and the necessary Precharge delay (trp) must occur before the SDRAM can enter the Power Down mode. Once the Power Down mode is initiated by holding CKE low, all of the receiver circuits except CLK and CKE are gated off. The Power Down mode does not perform any refresh operations, therefore the device can't remain in Power Down mode longer than the Refresh period (tref) of the device. Exit from this mode is performed by taking CKE "high". One clock delay is required for mode entry and exit.

Auto Precharge

Two methods are available to precharge SDRAMs. In an automatic precharge mode, the CAS timing accepts one extra address, A8, to determine whether the chip restores or not after the operation. If A8 is high when a Read Command is issued, the **Read with Auto-Precharge** function is initiated. The SDRAM automatically enters the precharge operation one clock before the last data out for $\overline{\text{CAS}}$ latencies 2, two clocks for $\overline{\text{CAS}}$ latencies 3. If A8 is high when a Write Command is issued, the **Write with Auto-Precharge** function is initiated. The SDRAM automatically enters the precharge operation a time delay equal to t_{WR} (Write recovery time) after the last data in.

Precharge Command

There is also a separate precharge command available. When $\overline{\text{RAS}}$ and $\overline{\text{WE}}$ are low and $\overline{\text{CAS}}$ is high at a clock timing, it triggers the precharge operation. With A8 being low, the BA is used select bank to precharge. The precharge command can be imposed one clock before the last data out for CAS latency = 2, two clocks before the last data out for CAS latency = 3. Writes require a time delay twr from the last data out to apply the precharge command.

Burst Termination

Once a burst read or write operation has been initiated, there are several methods in which to terminate the burst operation prematurely. These methods include using another Read or Write Command to interrupt an existing burst operation, use a Precharge Command to interrupt a burst cycle and close the active bank, or using the Burst Stop Command to terminate the existing burst operation but leave the bank open for future Read or Write Commands to the same page of the active bank. When interrupting a burst with another Read or Write Command care must be taken to avoid I/O contention. The Burst Stop Command, however, has the fewest restrictions making it the easiest method to use when terminating a burst operation before it has been completed. If a Burst Stop command is issued during a burst write operation, then any residual data from the burst write cycle will be ignored. Data that is presented on the I/O pins before the Burst Stop Command is registered will be written to the memory.

Absolute Maximum Ratings*

Operating temperature range 0 to 70 °C
 Storage temperature range -55 to 150 °C
 Input/output voltage -0.3 to (V_{CC}+0.3) V
 Power supply voltage -0.3 to 4.6 V
 Power dissipation 1 W
 Data out current (short circuit) 50 mA

***Note:** Stresses above those listed under “Absolute Maximum Ratings” may cause permanent damage of the device. Exposure to absolute maximum rating conditions for extended periods may affect device reliability.

Recommended Operation and Characteristics

T_A = 0 to 70 °C; V_{SS} = 0 V; V_{CC}, V_{CCQ} = 3.3 V ± 0.3 V

Parameter	Symbol	Limit Values		Unit	Notes
		min.	max.		
Input high voltage	V _{IH}	2.0	V _{CC} +0.3	V	1, 2
Input low voltage	V _{IL}	- 0.3	0.8	V	1, 2
Output high voltage (I _{OUT} = - 2.0 mA)	V _{OH}	2.4	-	V	3
Output low voltage (I _{OUT} = 2.0 mA)	V _{OL}	-	0.4	V	3
Input leakage current, any input (0 V < V _{IN} < 3.6 V, all other inputs = 0 V)	I _{I(L)}	- 5	5	μA	
Output leakage current (DQ is disabled, 0 V < V _{OUT} < V _{CC})	I _{O(L)}	- 5	5	μA	

Note:

1. All voltages are referenced to V_{SS}.
2. V_{IH} may overshoot to V_{CC} + 2.0 V for pulse width of < 4ns with 3.3V. V_{IL} may undershoot to -2.0 V for pulse width < 4.0 ns with 3.3V. Pulse width measured at 50% points with amplitude measured peak to DC reference.

Operating Currents ($T_A = 0$ to 70°C , $V_{CC} = 3.3\text{V} \pm 0.3\text{V}$)
 (Recommended Operating Conditions unless otherwise noted)

Symbol	Parameter & Test Condition		Max.					Unit	Note
			-5	-55	-6	-7	-8		
ICC1	Operating Current $t_{RC} = t_{RCMIN}$, $t_{RC} = t_{CKMIN}$. Active-precharge command cycling, without Burst Operation	1 bank operation	250	240	230	210	190	mA	3
ICC2P	Precharge Standby Current in Power Down Mode	$t_{CK} = \text{min.}$	2	2	2	2	2	mA	3
ICC2PS	$\overline{CS} = V_{IH}$, $CKE \leq V_{IL(max)}$	$t_{CK} = \text{Infinity}$	2	2	2	2	2	mA	3
ICC2N	Precharge Standby Current in Non-Power Down Mode	$t_{CK} = \text{min.}$	35	35	35	35	35	mA	
ICC2NS	$\overline{CS} = V_{IH}$, $CKE \geq V_{IL(max)}$	$t_{CK} = \text{Infinity}$	15	15	15	15	15	mA	
ICC3P	Active Standby Current in Power-down mode	$CKE \delta V_{IL(max)}$, $t_{ck} = \text{min}$	3	3	3	3	3	mA	
ICC3PS		$CKE \delta V_{IL(max)}$, $t_{ck} = \text{infinity}$	3	3	3	3	3	mA	
ICC3N	Active Standby Current in non Power-down mode	$CKE \checkmark V_{IL(max)}$, $t_{ck} = \text{min}$	60	60	60	60	60	mA	
ICC3NS		$CKE \checkmark V_{IL(max)}$, $t_{ck} = \text{infinity}$	50	50	50	50	50	mA	
ICC4	Burst Operating Current $t_{CK} = \text{min}$ Read/Write command cycling	CL = 3	340	320	310	280	250	mA	3, 4
		CL = 2	200	200	180	180	180		
ICC5	Auto Refresh Current $t_{CK} = \text{min}$ Auto Refresh command cycling		200	190	180	160	150	mA	3
ICC6	Self Refresh Current Self Refresh Mode, $CKE=0.2\text{V}$		2	2	2	2	2	mA	
		L-Power	400	400	400	400	400	μA	

Notes:

- These parameters depend on the cycle rate and these values are measured by the cycle rate under the minimum value of t_{CK} and t_{RC} . Input signals are changed one time during t_{CK} .
- These parameters are measured with continuous data stream during read access and all DQ toggling.

AC Characteristics (1,2,3)

$T_A = 0$ to 70°C ; $V_{SS} = 0\text{ V}$; $V_{CC} = 3.3\text{ V} \pm 0.3\text{ V}$, $t_T = 1\text{ ns}$

#	Symbol	Parameter	Limit Values										Unit
			-5		-55		-6		-7		-8		
			Min.	Max.	Min.	Max.	Min.	Max.	Min.	Max.	Min.	Max.	

Clock and Clock Enable

1	t_{CK}	Clock Cycle Time $\overline{\text{CAS}}$ Latency = 3 $\overline{\text{CAS}}$ Latency = 2	5	-	5.5	-	6	-	7	-	8	-	ns	
			10	-	10	-	10	-	10	-	10	-	ns	
2	t_{CK}	Clock Frequency $\overline{\text{CAS}}$ Latency = 3 $\overline{\text{CAS}}$ Latency = 2	-	200	-	200	-	166	-	143	-	125	MHz	
			-	100	-	100	-	100	-	100	-	100	MHz	
3	t_{AC}	Access Time from Clock $\overline{\text{CAS}}$ Latency = 3 $\overline{\text{CAS}}$ Latency = 2	-	5	-	5.5	-	6	-	6	-	6	ns	2
			-	7	-	7	-	7	-	7	-	7	ns	3
4	t_{CH}	Clock High Pulse Width	2.5	-	2.5	-	2.5	-	2.5	-	3	-	ns	
5	t_{CL}	Clock Low Pulse Width	2.5	-	2.5	-	2.5	-	2.5	-	3	-	ns	
6	t_T	Transition time	1	10	1	10	1	10	1	10	1	10	ns	

Setup and Hold Times

7	t_{CS}	Command Setup Time	2	-	2	-	2	-	2	-	2.5	-	ns	4
8	t_{AS}	Address Setup Time	2	-	2	-	2	-	2	-	2.5	-	ns	4
9	t_{DS}	Data In Setup Time	2	-	2	-	2	-	2	-	2.5	-	ns	4
10	t_{CKS}	CKE Setup Time	2	-	2	-	2	-	2	-	2.5	-	ns	4
11	t_{CH}	Command Hold Time	1	-	1	-	1	-	1	-	1	-	ns	4
12	t_{AH}	Address Hold Time	1	-	1	-	1	-	1	-	1	-	ns	4
13	t_{DH}	Data In Hold Time	1.5	-	1.5	-	1.5	-	1.5	-	1.5	-	ns	4
14	t_{CKH}	CKE Hold Time	1	-	1	-	1	-	1	-	1	-	ns	4

Common Parameters

15	t_{RCD}	Row to Column Delay Time	15	-	16	-	16	-	16	-	16	-	ns	5
16	t_{RAS}	Row Active Time	40	100K	45	100K	48	100K	48	100K	48	100K	ns	5
17	t_{RC}	Row Cycle Time	60	-	63	-	66	-	70	-	72	-	ns	5
18	t_{RP}	Row Precharge Time	15	-	17	-	18	-	21	-	24	-	ns	5
19	t_{RRD}	Activate(a) to Activate(b) Command period	10	-	11	-	12	-	14	-	16	-	ns	5
20	t_{CCD}	$\overline{\text{CAS}}$ (a) to $\overline{\text{CAS}}$ (b) Command period	1	-	1	-	1	-	1	-	1	-	CLK	
21	t_{RCS}	Mode Register Set-up time	10	-	11	-	12	-	14	-	16	-	ns	
22	t_{SB}	Power Down Mode Entry Time	0	5	0	5.5	0	6	0	7	0	8	ns	

Refresh Cycle

23	t_{REF}	Refresh Period (2048 cycles)	-	32	-	32	-	32	-	32	-	32	ms	
24	t_{SREX}	Self Refresh Exit Time	2 CLK + t_{RC}										6	

AC Characteristics ^(1,2,3) (Continued)

$T_A = 0$ to 70°C ; $V_{SS} = 0$ V; $V_{CC} = 3.3$ V \pm 0.3 V, $t_T = 1$ ns

#	Symbol	Parameter	Limit Values										Unit
			-5		-55		-6		-7		-8		
			Min.	Max.	Min.	Max.	Min.	Max.	Min.	Max.	Min.	Max.	
Read Cycle													
25	t_{OH}		2.5	–	2.5	–	2.5	–	2.5	–	2.5	–	ns
27	t_{HZ}	$\overline{\text{CAS}}$ Latency = 3	–	5	–	5.3	–	5.5	–	5.5	–	6	ns
		$\overline{\text{CAS}}$ Latency = 2	–	7	–	7	–	7	–	7	–	7	
28	t_{DQZ}	DQM Data Out Disable Latency	2	–	2	–	2	–	2	–	2	–	CLK
Write Cycle													
29	t_{WR}	Write Recovery Time											
		$\overline{\text{CAS}}$ Latency = 3	5	–	5.5	–	6	–	7	–	8	–	ns
		$\overline{\text{CAS}}$ Latency = 2	10	–	10	–	10	–	10	–	10	–	ns
30	t_{DQW}	DQM Write Mask Latency	0	–	0	–	0	–	0	–	0	–	CLK

Notes for AC Parameters:

- For proper power-up see the operation section of this data sheet.
- AC timing tests have $V_{IL} = 0.8\text{V}$ and $V_{IH} = 2.0\text{V}$ with the timing referenced to the 1.4 V crossover point. The transition time is measured between V_{IH} and V_{IL} . All AC measurements assume $t_T = 1$ ns with the AC output load circuit shown in Figure 1.

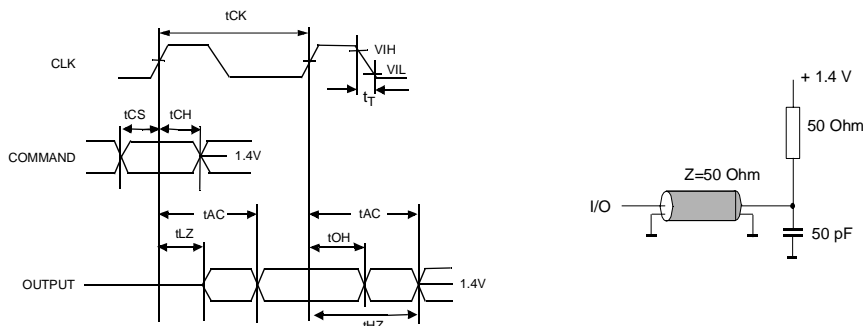

Figure 1.

- If clock rising time is longer than 1 ns, a time $(t_T/2 - 0.5)$ ns has to be added to this parameter.
- If t_T is longer than 1 ns, a time $(t_T - 1)$ ns has to be added to this parameter.
- These parameter account for the number of clock cycle and depend on the operating frequency of the clock, as follows:
the number of clock cycle = specified value of timing period (counted in fractions as a whole number)
- Self Refresh Exit is a synchronous operation and begins on the 2nd positive clock edge after CKE returns high. Self Refresh Exit is not complete until a time period equal to t_{RC} is satisfied once the Self Refresh Exit command is registered.

Timing Diagrams

1. Bank Activate Command Cycle
2. Burst Read Operation
3. Read Interrupted by a Read
4. Read to Write Interval
 - 4.1 Read to Write Interval
 - 4.2 Minimum Read to Write Interval
 - 4.3 Non-Minimum Read to Write Interval
5. Burst Write Operation
6. Write and Read Interrupt
 - 6.1 Write Interrupted by a Write
 - 6.2 Write Interrupted by Read
7. Burst Write & Read with Auto-Precharge
 - 7.1 Burst Write with Auto-Precharge
 - 7.2 Burst Read with Auto-Precharge
8. Burst Termination
 - 8.1 Termination of a Full Page Burst Write Operation
 - 8.2 Termination of a Full Page Burst Write Operation

1. Bank Activate Command Cycle

(CAS latency = 3)

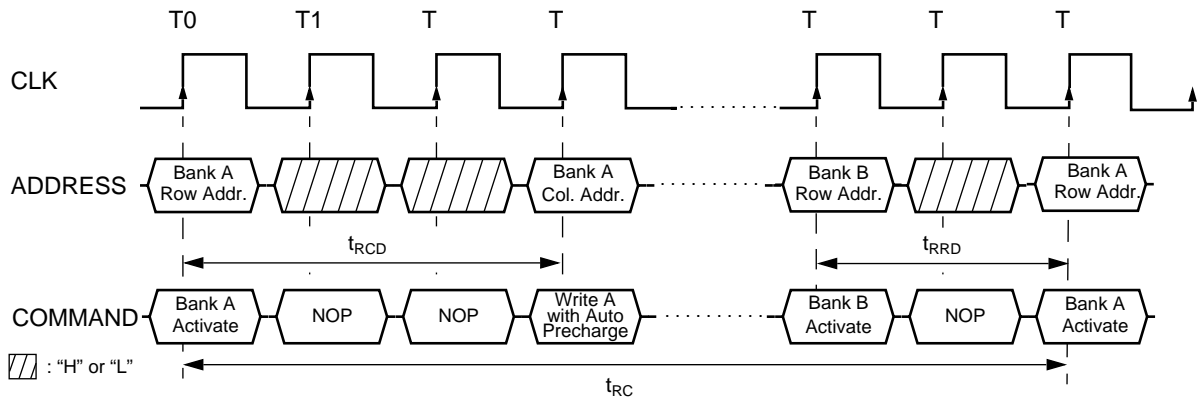

2. Burst Read Operation

(Burst Length = 4, CAS latency = 2, 3)

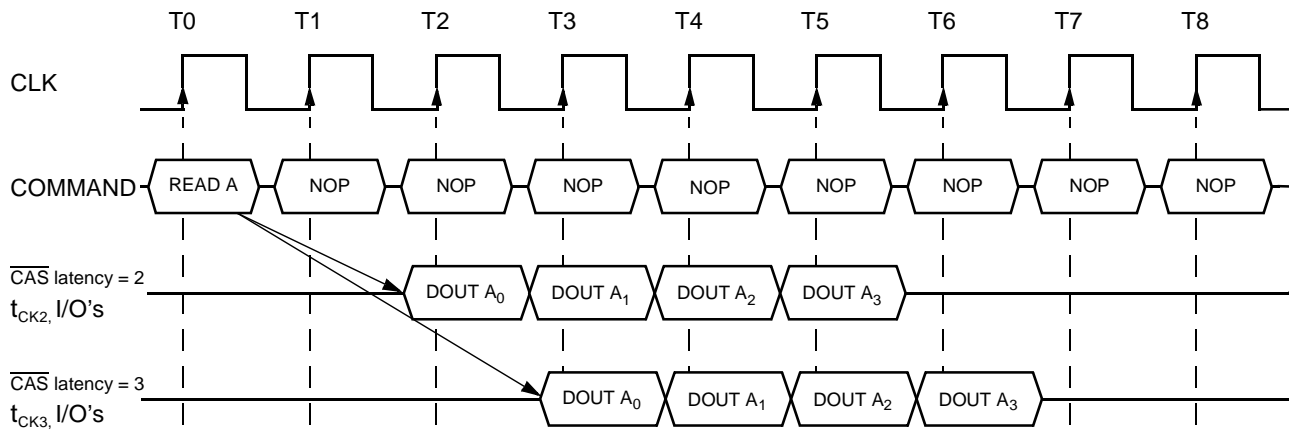

3. Read Interrupted by a Read

(Burst Length = 4, CAS latency = 2, 3)

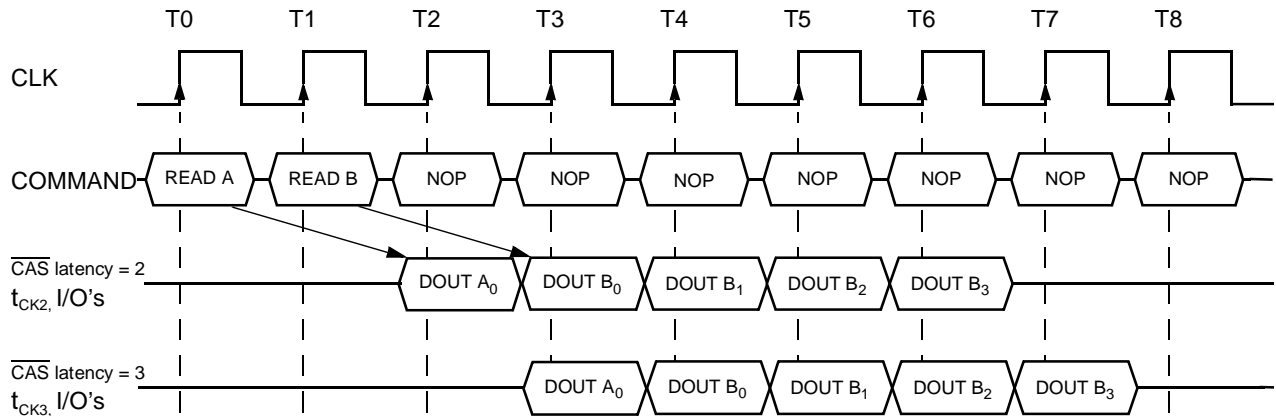

4.1 Read to Write Interval

(Burst Length = 4, CAS latency = 3)

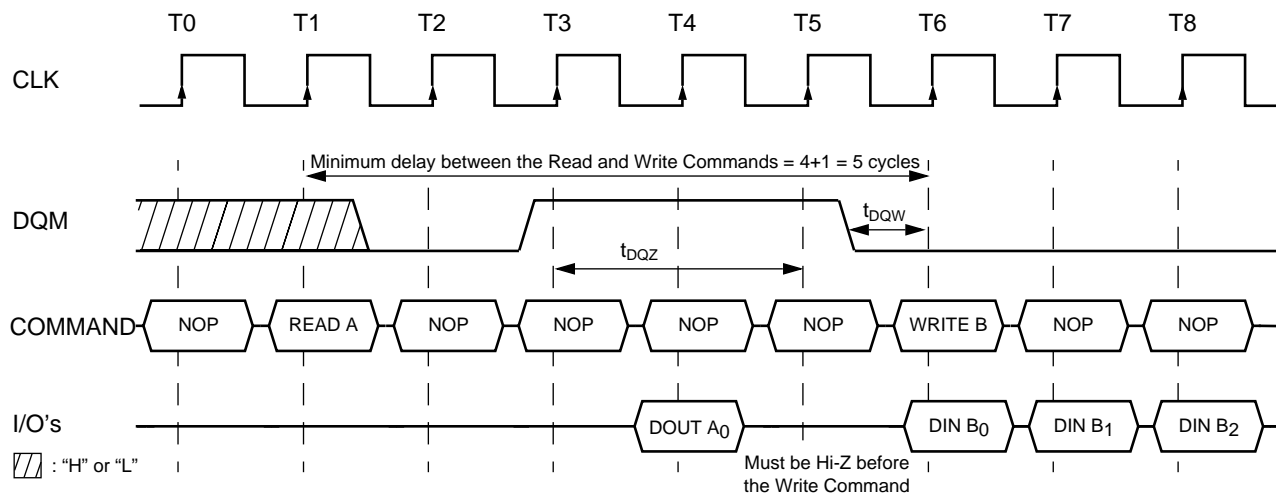

4.2 Minimum Read to Write Interval

(Burst Length = 4, CAS latency = 2)

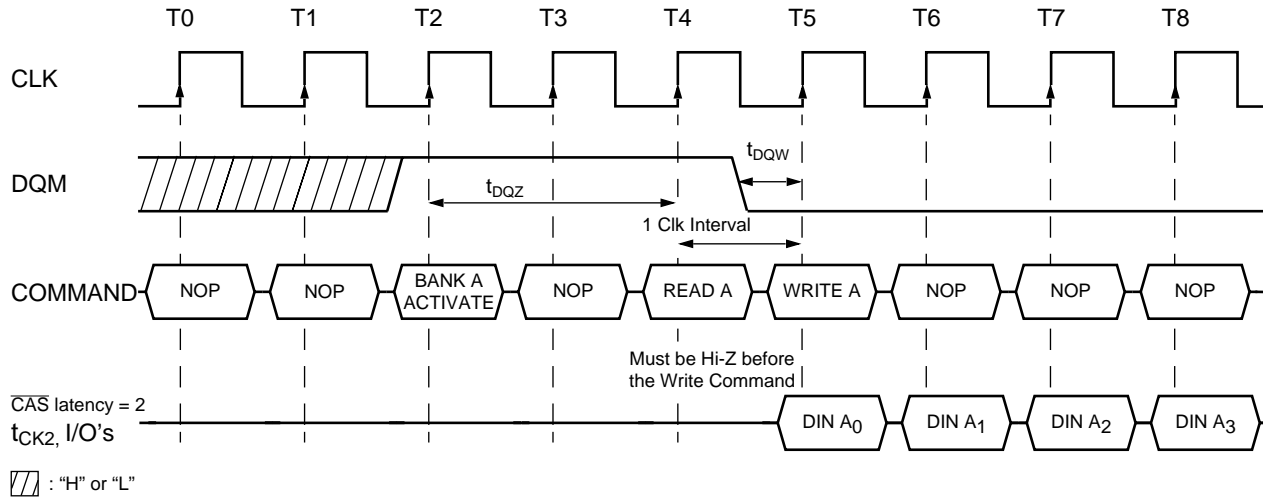

4.3 Non-Minimum Read to Write Interval

(Burst Length = 4, CAS latency = 2, 3)

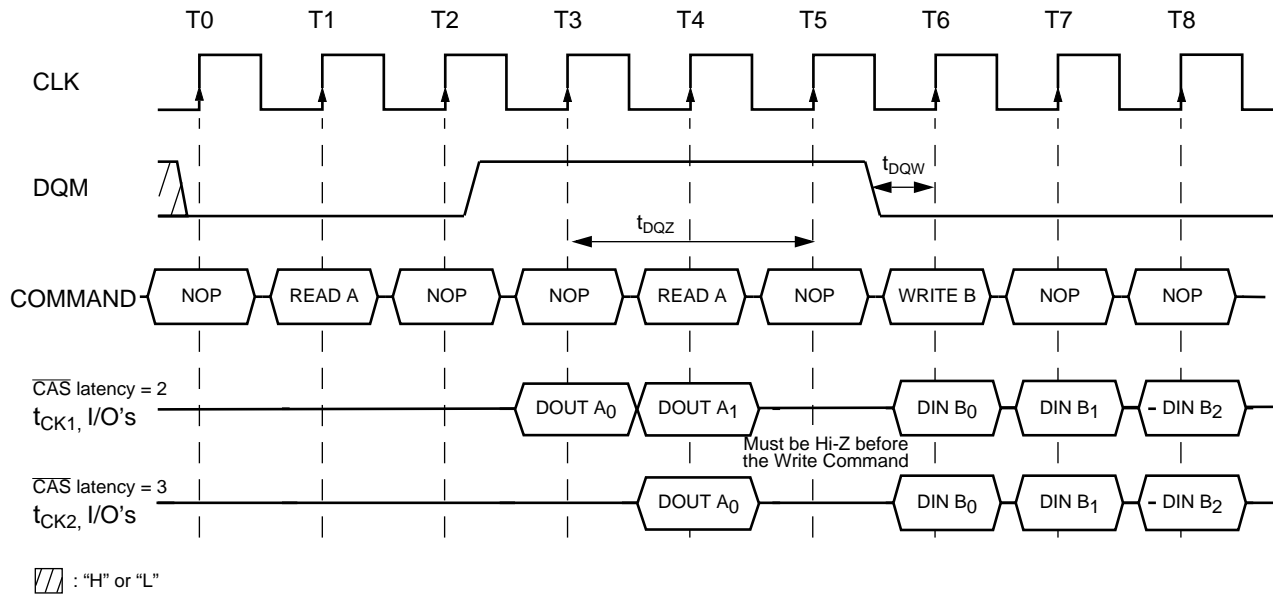

5. Burst Write Operation

(Burst Length = 4, $\overline{\text{CAS}}$ latency = 2, 3)

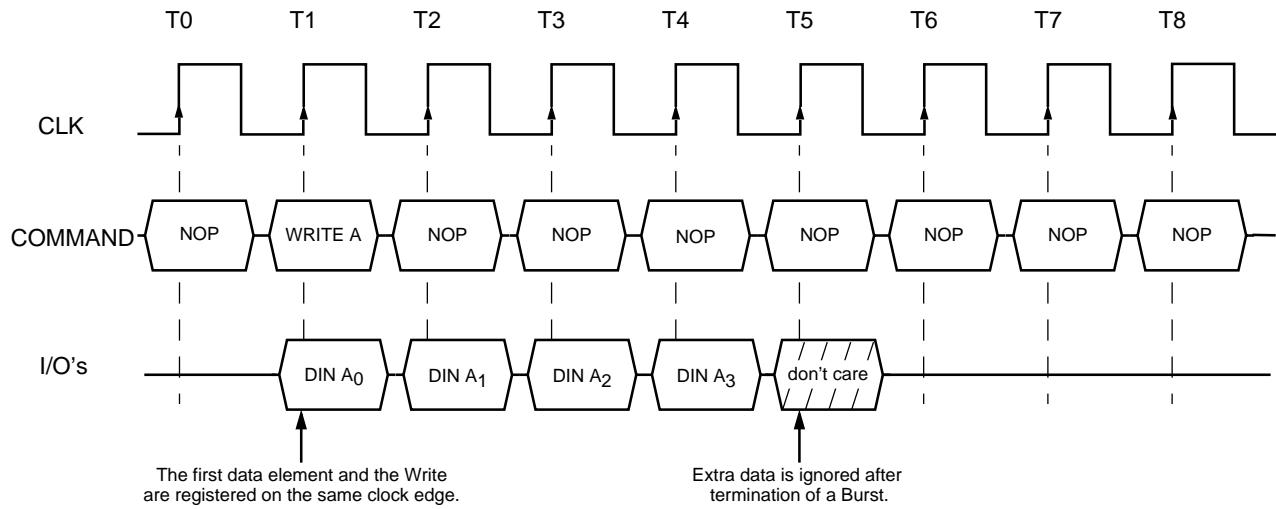

6.1 Write Interrupted by a Write

(Burst Length = 4, $\overline{\text{CAS}}$ latency = 2, 3)

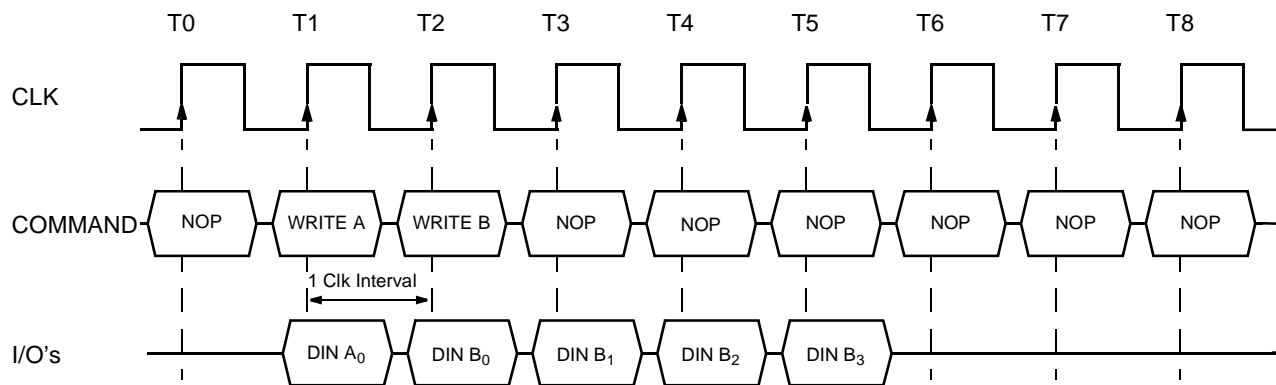

6.2 Write Interrupted by a Read

(Burst Length = 4, CAS latency = 2, 3)

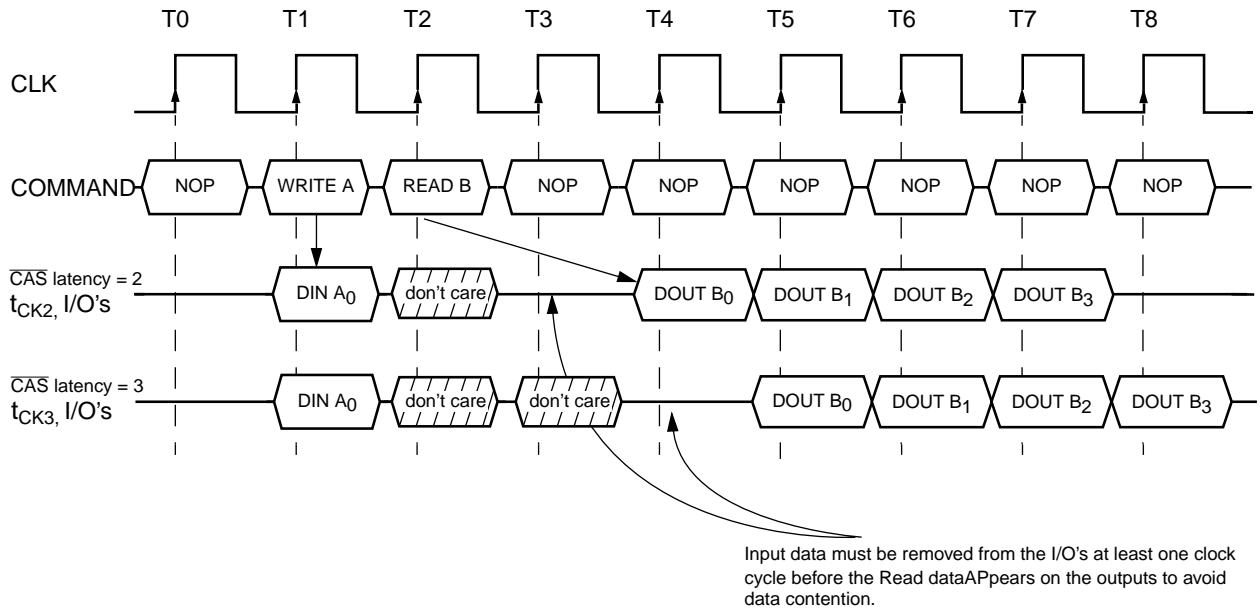

7. Burst Write with Auto-Precharge

Burst Length = 2, CAS latency = 2, 3)

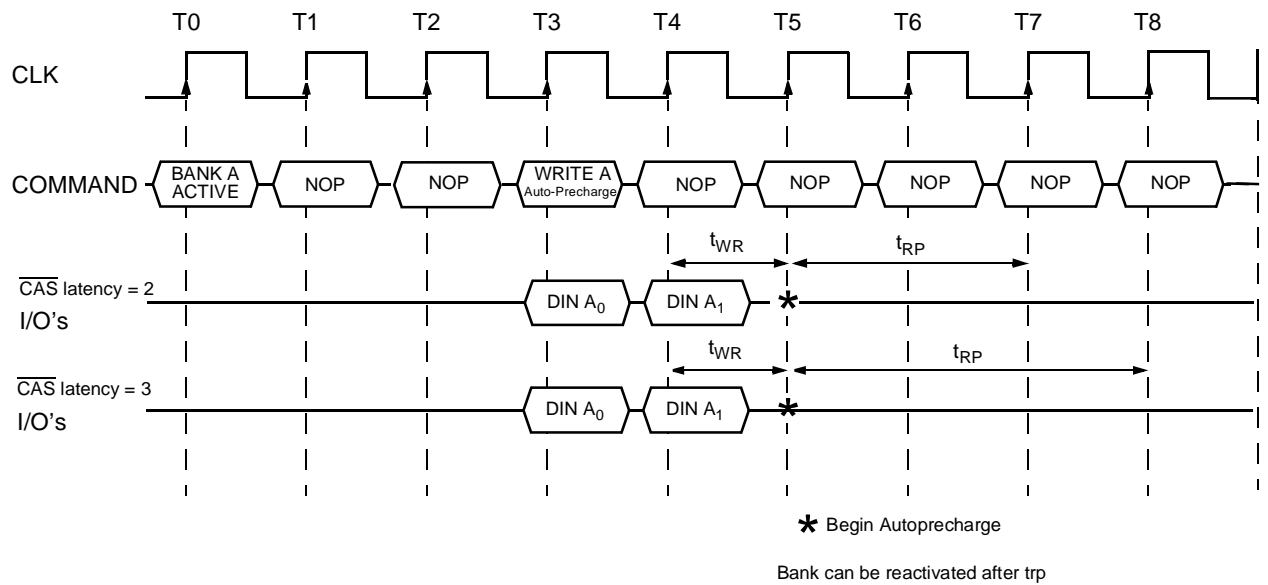

7.2 Burst Read with Auto-Precharge

Burst Length = 4, CAS latency = 1, 2, 3)

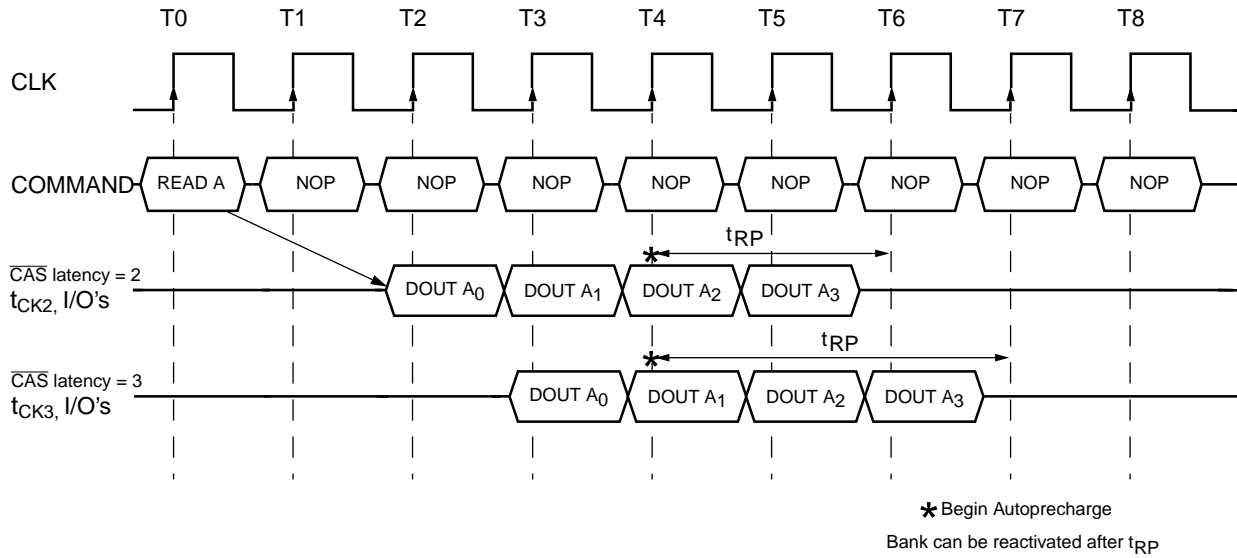

8.1 Termination of a Full Page Burst Read Operation

(CAS latency = 2, 3)

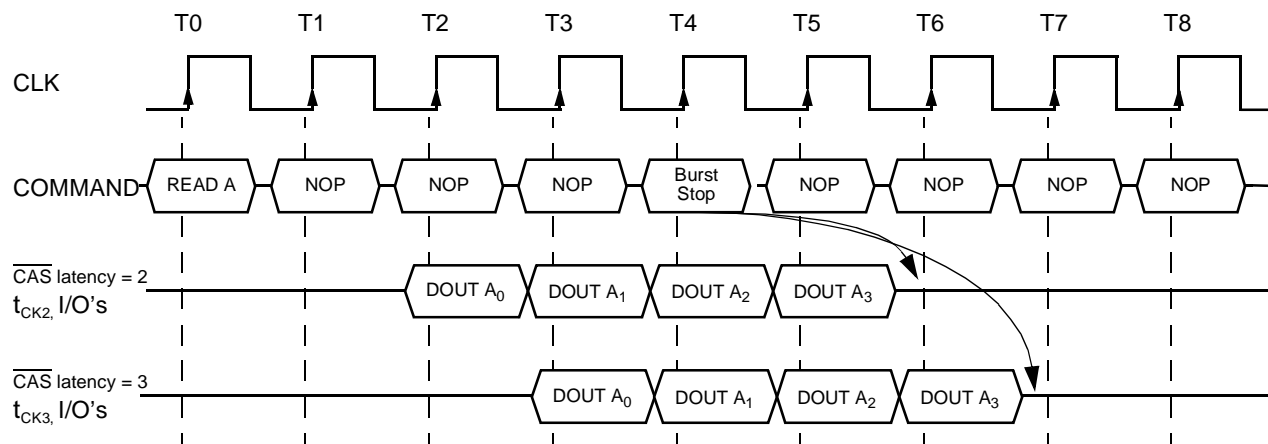

The burst ends after a delay equal to the $\overline{\text{CAS}}$ latency.

8.2 Termination of a Full Page Burst Write Operation

(CAS latency = 2, 3)

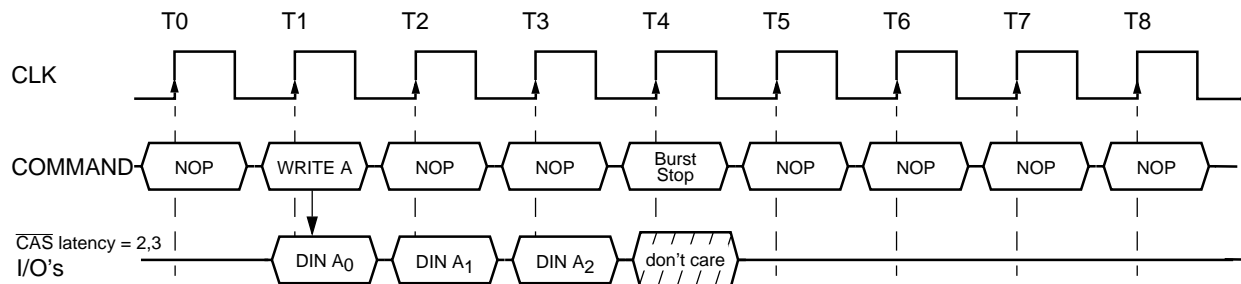

Input data for the Write is masked.

Package Diagram

86 TSOPII-400F

Unit: $\frac{\text{Millimeter}}{\text{Inches}}$

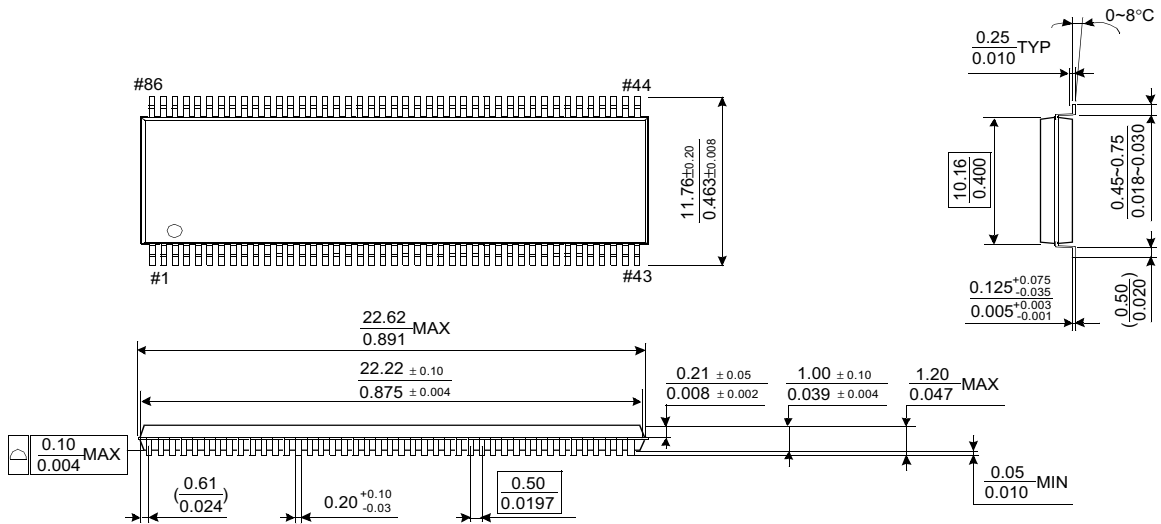

U.S.A.

3910 NORTH FIRST STREET
SAN JOSE, CA 95134
PHONE: 408-433-6000
FAX: 408-433-0952

TAIWAN

7F, NO. 102
MIN-CHUAN E. ROAD, SEC. 3
TAIPEI
PHONE: 886-2-2545-1213
FAX: 886-2-2545-1209

NO 19 LI HSIN ROAD
SCIENCE BASED IND. PARK
HSIN CHU, TAIWAN, R.O.C.
PHONE: 886-3-579-5888
FAX: 886-3-566-5888

SINGAPORE

10 ANSON ROAD #23-13
INTERNATIONAL PLAZA
SINGAPORE 079903
PHONE: 65-3231801
FAX: 65-3237013

JAPAN

ONZE 1852 BUILDING 6F
2-14-6 SHINTOMI, CHUO-KU
TOKYO 104-0041
PHONE: 03-3537-1400
FAX: 03-3537-1402

UK & IRELAND

SUITE 50, GROVEWOOD
BUSINESS CENTRE
STRATHCLYDE BUSINESS
PARK
BELLSHILL, LANARKSHIRE,
SCOTLAND, ML4 3NQ
PHONE: 44-1698-748515
FAX: 44-1698-748516

**GERMANY
(CONTINENTAL
EUROPE & ISRAEL)**

BENZSTRASSE 32
71083 HERRENBERG
GERMANY
PHONE: +49 7032 2796-0
FAX: +49 7032 2796 22

U.S. SALES OFFICES**NORTHWESTERN**

3910 NORTH FIRST STREET
SAN JOSE, CA 95134
PHONE: 408-433-6000
FAX: 408-433-0952

SOUTHWESTERN

302 N. EL CAMINO REAL #200
SAN CLEMENTE, CA 92672
PHONE: 949-361-7873
FAX: 949-361-7807

**CENTRAL,
NORTHEASTERN &
SOUTHEASTERN**

604 FIELDWOOD CIRCLE
RICHARDSON, TX 75081
PHONE: 214-352-3775
FAX: 214-904-9029

The information in this document is subject to change without notice.

MOSEL VITELIC makes no commitment to update or keep current the information contained in this document. No part of this document may be copied or reproduced in any form or by any means without the prior written consent of MOSEL-VITELIC.

MOSEL VITELIC subjects its products to normal quality control sampling techniques which are intended to provide an assurance of high quality products suitable for usual commercial applications. MOSEL VITELIC does not do testing appropriate to provide 100% product quality assurance and does not assume any liability for consequential or incidental arising from any use of its products. If such products are to be used in applications in which personal injury might occur from failure, purchaser must do its own quality assurance testing appropriate to such applications.