

### General Description

The AAT4650 SmartSwitch™ is a single channel PC Card (PCMCIA) power switch. It is used to select between two different voltage inputs, each between 2.7V and 5.5V. An internal switch powers the circuitry from whichever input voltage is higher. The device's output,  $V_{CC}$ , is slew rate controlled and current limited, in compliance with PC Card specifications. The current limit response time to a short circuit is typically 1 $\mu$ s. The internal P-Channel MOSFET switches are configured to break before make, that is, both switches cannot be closed at the same time. Controlled by a 2 bit parallel interface, the four states for  $V_{CC}$  are  $V_{CC5}$ ,  $V_{CC3}$ , Hi-impedance, or Ground. When in the ground state,  $V_{CC}$  is pulled to ground by a 5k $\Omega$  resistor. An open drain  $\overline{FAULT}$  output is asserted during over-current conditions. During power up slewing,  $\overline{FAULT}$  also signals that  $V_{CC}$  is out of tolerance. An internal over temperature sensor forces  $V_{CC}$  to a high impedance state when an over-temperature condition exists. Quiescent current is typically a low 15 $\mu$ A, as long as  $I_{CC}$  is less than approximately 500mA. Above this load current, the quiescent current increases to 200 $\mu$ A.

The AAT4650 is available in 8-pin SOP and TSSOP packages specified over -40 to 85°C.

### Features

- 2.7V to 5.5V Input voltage range
- 85m $\Omega$  (5V) typical  $R_{DS(ON)}$
- Low quiescent current 15 $\mu$ A (typ)
- Reverse-blocking switches
- Short-circuit protection
- Over-temperature protection
- $\overline{FAULT}$  flag output
- Temp range -40 to 85°C
- 8 pin SOP or TSSOP package

### Applications

- Notebook Computer
- PDA, Subnotebook
- Power Supply Multiplexer Circuit

### Typical Application

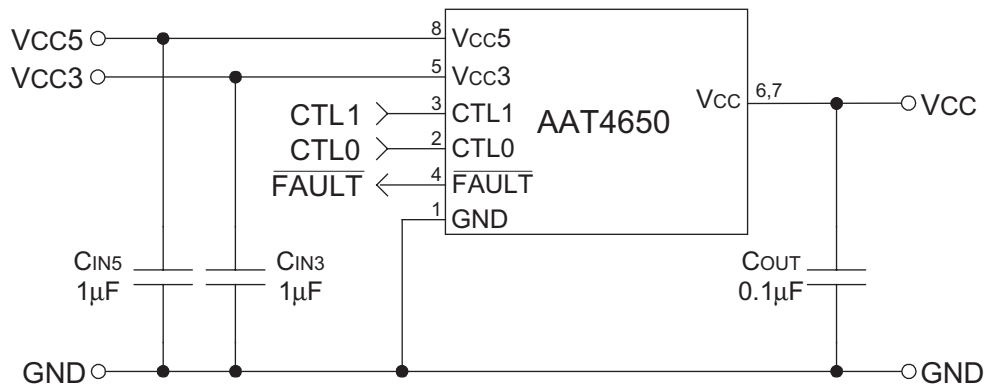

### Pin Descriptions

Pin #	Symbol	Function
1	GND	Ground connection
2	CTL0	Control input (see Control Logic Table below)
3	CTL1	Control input (see Control Logic Table below)
4	$\overline{\text{FAULT}}$	Open drain output signals over-current condition
5	$V_{CC3}$	3V supply
6	$V_{CC}$	Output (see Control Logic Table below)
7	$V_{CC}$	Output (see Control Logic Table below)
8	$V_{CC5}$	5V supply

### Pin Configuration

**SO-8 / TSSOP-8**  
**(Top View)**

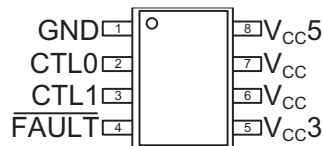

### Control Logic Table

CTL1	CTL0	Function	Result
0	0	OFF	5k $V_{CC}$ to GND
0	1	5v	$V_{CC}=V_{CC5}$
1	0	3v	$V_{CC}=V_{CC3}$
1	1	HiZ	Both FETs OFF

### Absolute Maximum Ratings ( $T_A=25^\circ\text{C}$ unless otherwise noted)

Symbol	Description	Value	Units
$V_{CC3}, V_{CC5}$	IN to GND	-0.3 to 6	V
$V_{CC}$	OUT to GND	-0.3 to 6	V
$I_{MAX}$	Maximum Continuous Switch Current	Current Limited	A
$T_J$	Operating Junction Temperature Range	-40 to 150	$^\circ\text{C}$
$T_{LEAD}$	Maximum Soldering Temperature (at Leads)	300	$^\circ\text{C}$
$V_{ESD}$	ESD Rating <sup>1</sup> — HBM	4000	V

Note: Stresses above those listed in Absolute Maximum Ratings may cause permanent damage to the device. Functional operation at conditions other than the operating conditions specified is not implied. Only one Absolute Maximum rating should be applied at any one time.

Note 1: Human body model is a 100pF capacitor discharged through a 1.5k $\Omega$  resistor into each pin.

### Thermal Characteristics

Symbol	Description	Value	Units
$\Theta_{JA}$	Thermal Resistance (SOP-8) <sup>2</sup>	100	$^\circ\text{C}/\text{W}$
$P_D$	Power Dissipation (SOP-8) <sup>2</sup>	1.25	W

Note 2: Mounted on an FR4 board.

### Electrical Characteristics ( $V_{IN} = 5\text{V}$ , $T_A = -40$ to $85^\circ\text{C}$ unless otherwise noted. Typical values are at $T_A=25^\circ\text{C}$ ; **bold** values designate full temperature range)

Symbol	Description	Conditions	Min	Typ	Max	Units
<b><math>V_{CC}</math> Output</b>						
$I_{CC}$ Hi-Z	High impedance Output Leakage Current	OFF mode, $V_{CC}=0\text{V}$			<b>1</b>	$\mu\text{A}$
$I_{CCSC}$	Short Circuit Current Limit	$V_{CC}=V_{CCIN} - 0.5\text{V}$ , ON mode $V_{CC3}$ or $V_{CC5}$ selected, $T_A=25^\circ\text{C}$	1.0		2.0	A
$R_{DS(ON)}$	On-Resistance	$V_{CC}=3.0\text{V}$ , $T_A=25^\circ\text{C}$		85	110	m $\Omega$
		$V_{CC}=5.0\text{V}$ , $T_A=25^\circ\text{C}$		80	100	m $\Omega$
$\tau_{crds}$	Switch Resistance Tempco			2800		ppm/ $^\circ\text{C}$
<b><math>V_{CC}</math> Switching Time (Refer to Figure 1)</b>						
t1	Output Turn-On Delay Time	$V_{CC}=0\text{V}$ to 10% of 3.3V, $R_{OUT}=10\Omega$		500	<b>2000</b>	$\mu\text{s}$
t2	Output Turn-On Delay Time	$V_{CC}=0\text{V}$ to 10% of 5.0V, $R_{OUT}=10\Omega$		500	<b>1500</b>	$\mu\text{s}$
t3	Output Rise Time	$V_{CC}=10\%$ to 90% of 3.3V, $R_{LOAD}=10\Omega$	<b>300</b>	1000	<b>3000</b>	$\mu\text{s}$
t4	Output Rise Time	$V_{CC}=10\%$ to 90% of 5.0V, $R_{LOAD}=10\Omega$	<b>300</b>	1000	<b>3000</b>	$\mu\text{s}$
t5	Output Turn-Off Delay Time	$V_{CC}=3.3$ to 90% of 3.3V, $R_{LOAD}=10\Omega$			<b>400</b>	$\mu\text{s}$
t6	Output Turn-Off Delay Time	$V_{CC}=5.0$ to 90% of 5.0V, $R_{LOAD}=10\Omega$			<b>400</b>	$\mu\text{s}$
t7	Output Fall Time to OFF State	$V_{CC}=90\%$ to 10% of 3.3V, $R_{LOAD}=10\Omega$			<b>200</b>	$\mu\text{s}$
t8	Output Fall Time to OFF State	$V_{CC}=90\%$ to 10% of 5.0V, $R_{LOAD}=10\Omega$			<b>200</b>	$\mu\text{s}$
t9	Output Fall Time to Hi-Z State	$V_{CC}=90\%$ to 10% of 3.3V, $R_{LOAD}=10\Omega$			<b>1500</b>	$\mu\text{s}$
t10	Output Fall Time to Hi-Z State	$V_{CC}=90\%$ to 10% of 5.0V, $R_{LOAD}=10\Omega$			<b>2000</b>	$\mu\text{s}$

Symbol	Description	Conditions	Min	Typ	Max	Units
<b>Power Supply</b>						
$V_{CC3}$	$V_{CC3}$ Operation Voltage		2.7		5.5	V
$V_{CC5}$	$V_{CC5}$ Operation Voltage		2.7		5.5	V
$I_{CC3}$	$V_{CC3}$ Supply Current	$V_{CC}=5V$ or HiZ or OFF, $V_{CC3}<V_{CC5}$ , $I_{CC}$ Out=0			<b>1</b>	$\mu A$
		$V_{CC}=3.3v$ , $V_{CC3}<V_{CC5}$ , $I_{CC}$ Out=0		5	<b>20</b>	$\mu A$
$I_{CC5}$	$V_{CC5}$ Supply Current	$V_{CC}=\text{Off}$ , $V_{CC5}>V_{CC3}$ , $I_{CC}$ Out=0			<b>1</b>	$\mu A$
		$V_{CC}=\text{HiZ}$ , $V_{CC5}>V_{CC3}$ , $I_{CC}$ Out=0		10	<b>40</b>	$\mu A$
		$V_{CC}=3.3v$ , $V_{CC5}>V_{CC3}$ , $I_{CC}$ Out=0		10	<b>40</b>	$\mu A$
		$V_{CC}=5v$ , $V_{CC5}>V_{CC3}$ , $I_{CC}$ Out=0		15	<b>40</b>	$\mu A$
<b>Parallel Interface</b>						
$V_{CTLLOW}$	CTL Input Low Voltage				<b>0.8</b>	V
$V_{CTLHI}$	CTL Input High Voltage	$V_{CC3}$ or $V_{CC5}=2.7$ to $3.6V$	<b>2.0</b>			V
		$V_{CC3}$ or $V_{CC5}=4.5$ to $5.5V$	<b>2.4</b>			V
$I_{SINKCTL}$	CTL Input leakage	$V_{CTL} = 5.5V$		0.01	<b>1</b>	$\mu A$
$V_{FAULTLOW}$	$\overline{FAULT}$ Logic Output Low Voltage	$I_{SINK}=1mA$			<b>0.4</b>	V
$I_{SINKFAULT}$	$\overline{FAULT}$ Logic Output High Leakage Current	$V_{FAULT} = 5.5V$		0.05	<b>1</b>	$\mu A$
<b>Other</b>						
OTMP	Over Temperature Shutdown			125		degC

## Timing Diagram

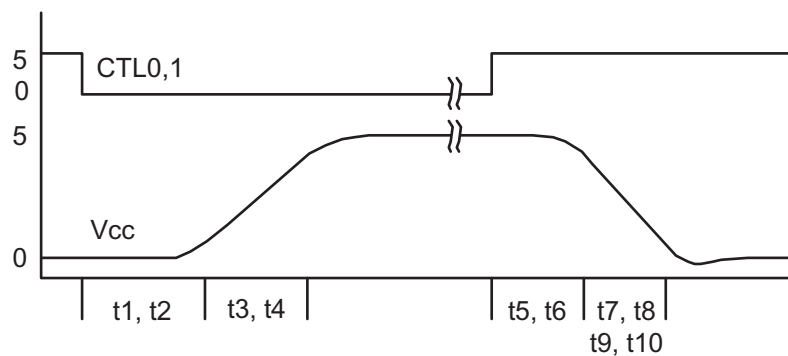

**Figure 1:  $V_{CC}$  Switching Time Diagram**

Refer to  $V_{CC}$  Switching Time specifications under the Electrical Characteristics section for definitions of t1 to t10.

### Typical Characteristics

(Unless otherwise noted,  $T_A = 25^\circ\text{C}$ )

**Quiescent Current vs. Temperature**  
( $I_{CC5}$ )

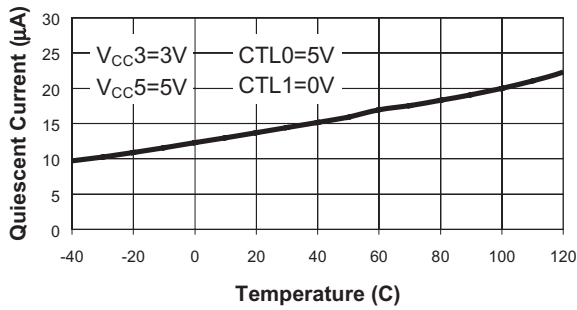

**Current Limit  $V_{CC}=V_{CC3}$**

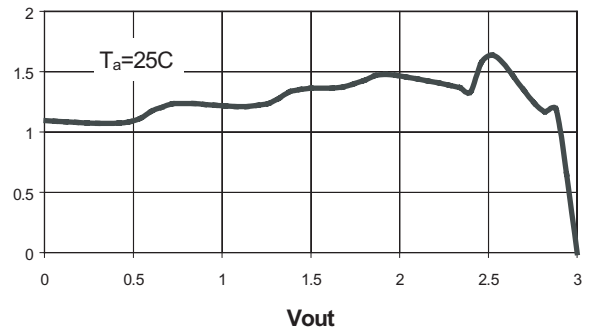

**Current Limit  $V_{CC}=V_{CC5}$**

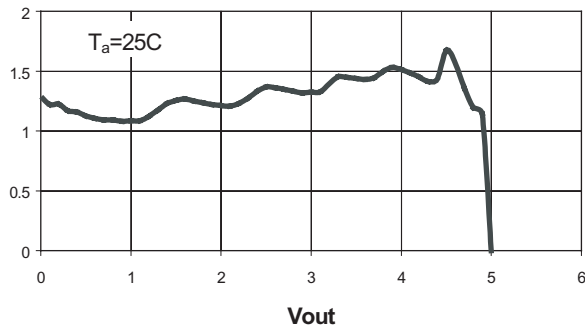

**Off-Switch Current vs. Temperature ( $I_{CC3}$ )**

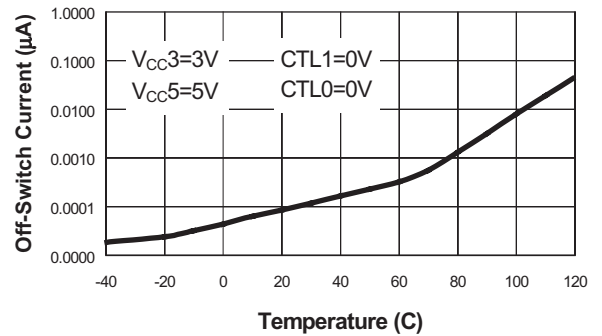

**Off-Switch Current vs. Temperature  $I_{CC5}$**

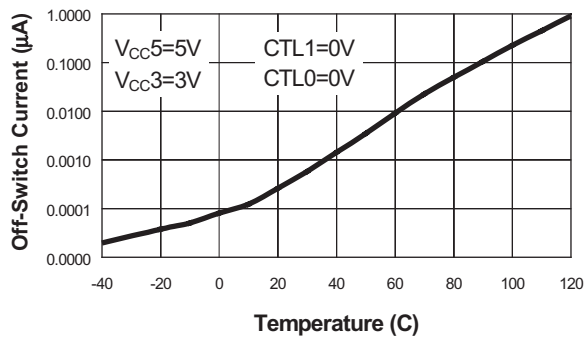

**$R_{dson}$  vs. Temperature**

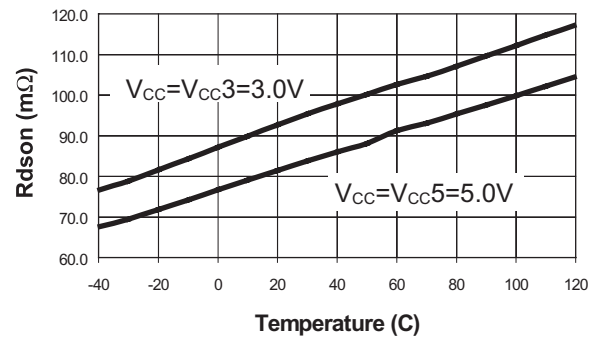

(Unless otherwise noted,  $T_A = 25^\circ\text{C}$ )

**Turn-ON/OFF Response with 10 Ohm  $1\mu\text{F}$  load**

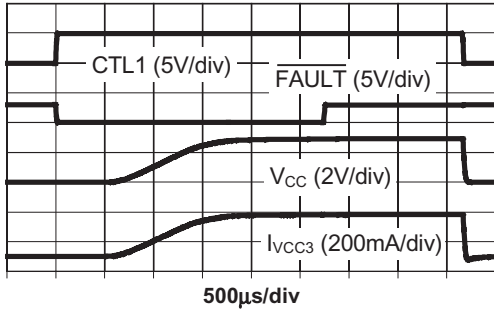

**Turn-ON/OFF Response with 15 Ohm  $1\mu\text{F}$  load**

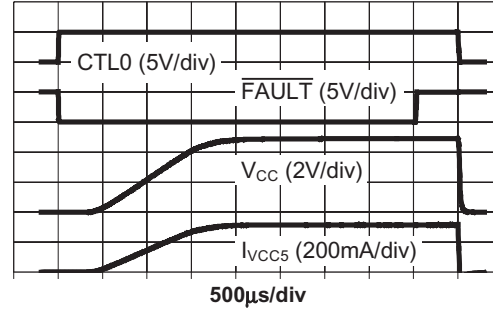

**Thermal Shutdown Response**

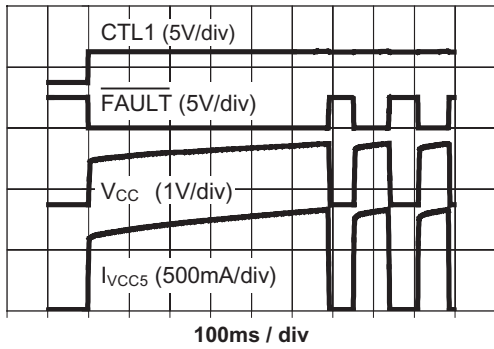

**Short Circuit Through 0.3 Ohm**

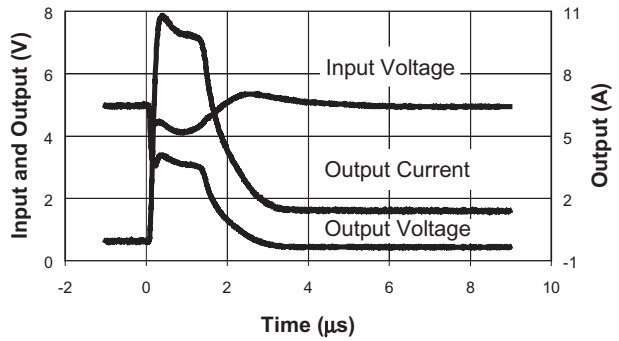

**Short Circuit Through 0.6 Ohm**

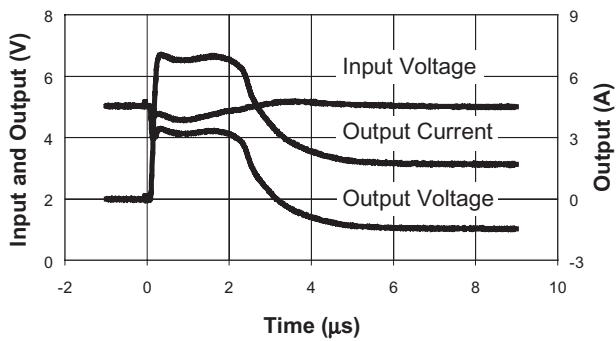

### Functional Block Diagram

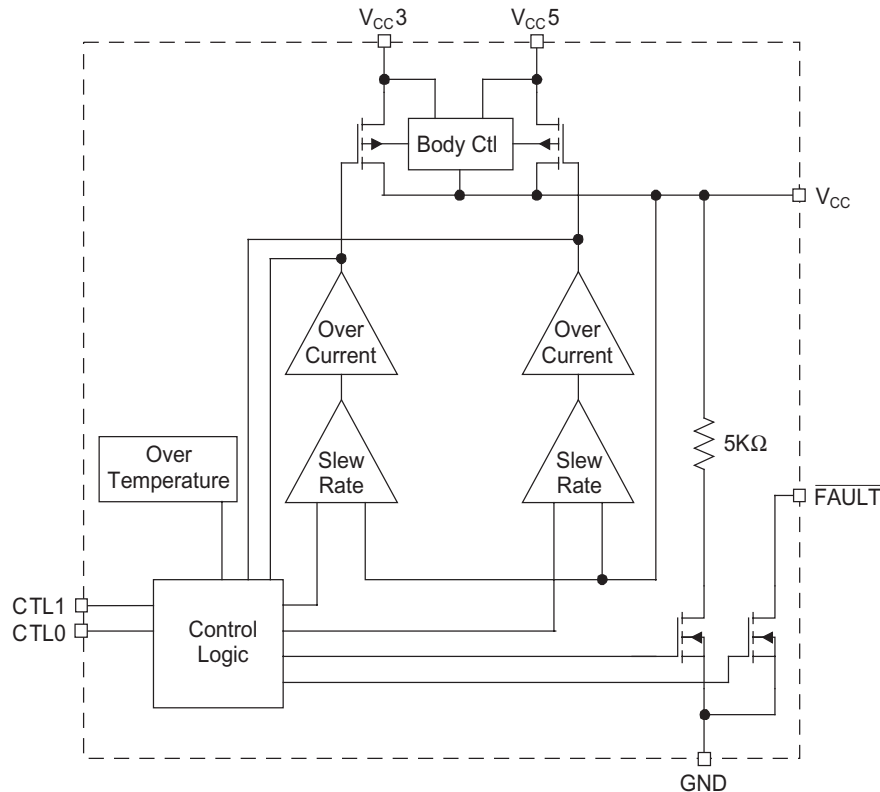

### Functional Description

The AAT4650 is a single channel power switch that can be used in any application where dual power supply multiplexing is required. Typical applications for this include PC card applications not requiring a 12 volt power supply, or applications where power is switched, for example, between 5 volts for operation and 3.3 volts for standby mode. The AAT4650 operates with input voltages ranging from 2.7 to 5.5 volts in any combination and automatically powers its internal circuitry off of whichever input voltage is higher. Two identical low  $R_{DS}$  P-channel MOSFETS serve as the power multiplexing circuit with a common drain as the  $V_{CC}$  output and independent sources as the two  $V_{CC3}$  and  $V_{CC5}$  inputs. A two bit parallel interface determines the state of the multiplexer:  $V_{CC}=V_{CC3}$ ,  $V_{CC}=V_{CC5}$ ,  $V_{CC}$  with resistive pull down to ground, or  $V_{CC}$  hi-impedance. When the state is set to either of the two inputs, the multiplex-

ing circuit will slowly slew the  $V_{CC}$  output to the new voltage level which protects the upstream power supply from sudden load transients. When the resistive pull down is chosen for  $V_{CC}$ , the  $V_{CC}$  output is quickly discharged by the resistive pull down. The AAT4650 always serves as an electronic fuse by limiting the load current if it exceeds the current limit threshold. During power up into a short, the current will gradually increase until the current limit is reached. During a sudden short circuit on the output, the current limit will respond in 1  $\mu$ s to isolate and protect the upstream power supply from the load short circuit. In most applications, because the response time is so fast, a short circuit to  $V_{CC}$  will not affect the upstream supply, so system functionality will not be affected. In the case of an over current condition, an open drain FAULT flag output will signal the event. The FAULT output is also active during output voltage slew, and becomes inactive once the output is within regulation.

## Applications Information

### Input Capacitor

Typically a 1µF or larger capacitor is recommended for  $C_{IN}$ . A  $C_{IN}$  capacitor is not required for basic operation, however, it is useful in preventing load transients from affecting up stream circuits.  $C_{IN}$  should be located as close to the device  $V_{IN}$  pin as practically possible. Ceramic, tantalum or aluminum electrolytic capacitors may be selected for  $C_{IN}$ . There is no specific capacitor ESR requirement for  $C_{IN}$ . However, for higher current operation, ceramic capacitors are recommended for  $C_{IN}$  due to their inherent capability over tantalum capacitors to withstand input current surges from low impedance sources such as batteries in portable devices.

### Output Capacitor

A 0.1µF or greater capacitor is generally required between  $V_{CC}$  and GND. Likewise, with the output capacitor, there is no specific capacitor ESR requirement. If desired,  $C_{OUT}$  may be increased to accommodate any load transient condition.

### Parallel Interface / Break Before Make

A two bit parallel interface determines the state of the  $V_{CC}$  output. The logic levels are compatible with CMOS or TTL logic. A logic low value must be less than 0.8 volts, and a logic high value must be greater than 2.4 volts. In cases where the interface pins rapidly change state directly from 3v to 5v (or vice versa), internal break before make circuitry prevents any back flow of current from one input power supply to the other. In addition, the body connections of the internal P-channel MOSFET switches are always set to the highest potential of  $V_{CC3}$ ,  $V_{CC5}$ , or  $V_{CC}$ , which prevents any body diode conduction, power supply backflow, or possible device damage.

### FAULT Output

The  $\overline{FAULT}$  output is pulled to ground by an open drain N-channel MOSFET during an over current or output slew condition. It should be pulled up to the reference power supply of the controller IC via a nominal 100KΩ resistor.

### Voltage Regulation

The PC Card Specification calls for a regulated 5 volt supply tolerance of +/-5%. Of this, a typical power supply will drop less than 2%, and the PCB traces will drop another 1%. This leaves 2% for the AAT4650 as the PC card switch. In the PC card application, the maximum allowable current for the

AAT4650 is dominated by voltage regulation rather than by thermal considerations, and is set by either the current limit or the maximum  $R_{DS}$  of the P-channel MOSFET. The maximum  $R_{DS}$  at 85°C is calculated by applying the  $R_{DS}$  Tempco to the maximum room temperature  $R_{DS}$ :

$$R_{DS(MAX)} = R_{DS25} \times (1 + TC \times \Delta T), \text{ or}$$

$$R_{DS(MAX)} = 105m\Omega \times (1 + 0.0028 \times 60) = 122m\Omega$$

The maximum current is equal to the 2% tolerance of the 5 volt supply (100mV) across the AAT4650 divided by  $R_{DS(MAX)}$ . Or

$$I_{MAX5} = 100mV / 122m\Omega = 820mA$$

For the 3.3 volt supply in the PC card application, the conditions are a bit relaxed, with the allowable voltage regulation drop equal to 300mV. With a 2% supply, and 1% PCB trace regulation, the PC card switch can have a 200mV drop. So

$$I_{MAX3} = 200mV / 134m\Omega = 1.5A$$

Since 1.5A is the nominal current limit value, the AAT4650 will current limit before  $I_{MAX3}$  is reached.

Thermal issues are not a problem in the SO-8 package since  $\Theta_{JA}$ , the package thermal resistance, is only 120°C/W. At any given ambient temperature ( $T_A$ ) the maximum package power dissipation can be determined by the following equation:

$$P_{D(MAX)} = [T_{J(MAX)} - T_A] / \Theta_{JA}$$

Constants for the AAT4650 are maximum junction temperature,  $T_{J(MAX)} = 125^\circ C$ , and package thermal resistance,  $\Theta_{JA} = 120^\circ C/W$ . Worst case conditions are calculated at the maximum operating temperature where  $T_A = 85^\circ C$ . Typical conditions are calculated under normal ambient conditions where  $T_A = 25^\circ C$ . At  $T_A = 85^\circ C$ ,  $P_{D(MAX)} = 333mW$ . At  $T_A = 25^\circ C$ ,  $P_{D(MAX)} = 833mW$ .

Maximum current is given by the following equation:

$$I_{OUT(MAX)} = (P_{D(MAX)} / R_{DS})^{1/2}$$

For the AAT4650 at 85°C,  $I_{OUT(MAX)} = 1.65A$ , a value greater than the internal minimum current limit specification.

### Overcurrent and Overtemperature Protection

Because many AAT4650 applications provide power to external devices, it is designed to protect its host device from malfunctions in those peripherals



through slew rate control, current limiting, and thermal limiting. The AAT4650 current limit and thermal limit serve as an immediate and reliable electronic fuse without any increase in  $R_{DS}$  for this function. Other solutions such as a poly fuse do not protect the host power supply and system from mishandling, or short circuited peripherals, they will only prevent a fire. The AAT4650 high speed current limit and thermal limit not only prevent fires, they also isolate the power supply and entire system from any activity at the external port, and report a mishap by means of a  $\overline{FAULT}$  signal.

Overcurrent and overtemperature go hand in hand. Once an overcurrent condition exists, the current supplied to the load by the AAT4650 is limited to the overcurrent threshold. This results in a voltage drop across the AAT4650 which causes excess power dissipation and a package temperature increase. As the die begins to heat up, the overtemperature circuit is activated. If the temperature reaches the maximum level, the AAT4650 automatically switches off the P-channel MOSFETs. While they are off, the overtemperature circuit remains active. Once the temperature has cooled by approximately  $10^{\circ}\text{C}$ , the P-channel MOSFETs are switched back on. In this manner, the AAT4650 is thermally cycled on and off until the short circuit is removed. Once the short is removed, normal operation automatically resumes.

To save power, the full high speed overcurrent circuit is not activated until a lower threshold of current (approximately 700mA) is exceeded in the power device. When the load current exceeds this

crude threshold, the AAT4650 quiescent current increases from  $15\mu\text{A}$  to  $150\mu\text{A}$ . The high speed overcurrent circuit works by linearly limiting the current when the current limit is reached. As the voltage begins to drop on  $V_{CC}$  due to current limiting, the current limit magnitude varies, and generally decreases as the  $V_{CC}$  voltage drops to 0 volts.

### Switching Vcc Voltage

The AAT4650 meets PC card standards for switching the  $V_{CC}$  output by providing a ground path for  $V_{CC}$  as well as a hi impedance state. The PC card protocol for determining low voltage operations is to first power the peripheral with 5 volts and poll for 3.3 volt operation. When transitioning from 5 volts to 3.3 volts,  $V_{CC}$  must be discharged to less than 0.8 volts to provide a hard reset. The resistive ground state ( $CTL1=0$ ,  $CTL0=0$ ) will accommodate this. The ground state will also guarantee the  $V_{CC}$  voltage to be discharged within the specified 100ms amount of time.

### Printed Circuit Board Layout Recommendations

For proper thermal management, to minimize PCB trace resistance, and to take advantage of the low  $R_{DS(ON)}$  of the AAT4650, a few circuit board layout rules should be followed:  $V_{CC3}$ ,  $V_{CC5}$ , and  $V_{CC}$  should be routed using wider than normal traces, the two  $V_{CC}$  pins (6 and 7) should be connected to the same wide PCB trace, and GND should be connected to a ground plane. For best performance,  $C_{IN}$  and  $C_{OUT}$  should be placed close to the package pins.

### Typical PC Card Application Circuit

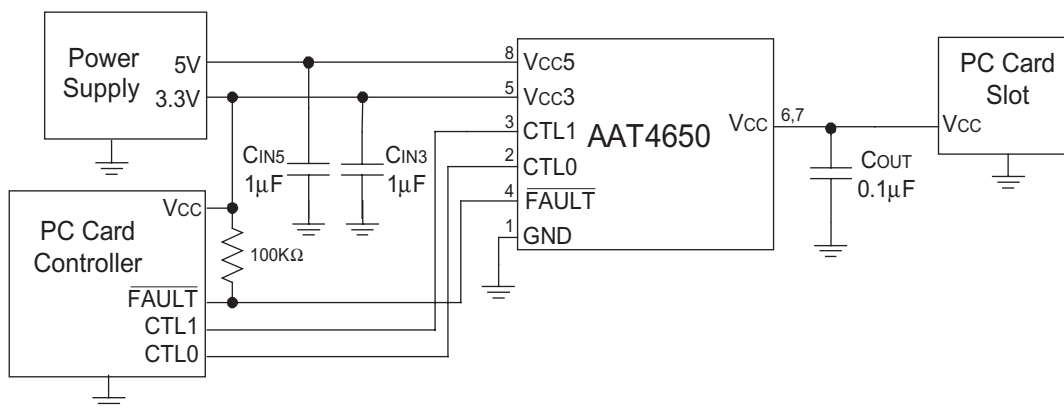

## Evaluation Board Layout

The AAT4650 evaluation layout follows the printed circuit board layout recommendations, and can be used for good applications layout.

Note: Board layout shown is not to scale.

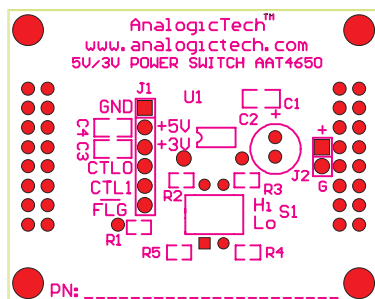

**Figure 2: Evaluation board top side silk screen layout / assembly drawing**

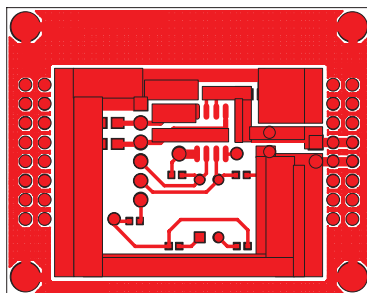

**Figure 3: Evaluation board component side layout**

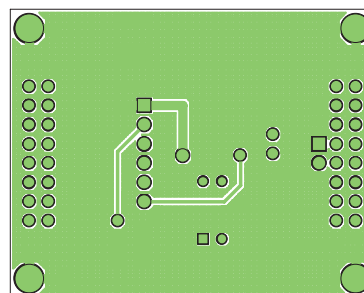

**Figure 4: Evaluation board solder side layout**

### Ordering Information

Package	Marking	Part Number	
		Bulk	Tape and Reel
SO-8		AAT4650IAS-B1	AAT4650IAS-T1
TSSOP-8		AAT4650IHS-B1	AAT4650IHS-T1

### Package Information

#### SOP-8

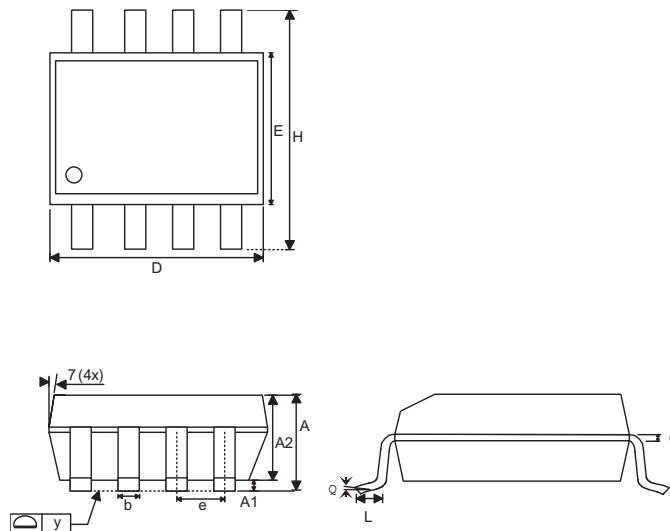

Dim	Millimeters		Inches	
	Min	Max	Min	Max
A	1.35	1.75	0.053	0.069
A1	0.10	0.25	0.004	0.010
A2	1.45		0.057	
B	0.33	0.51	0.013	0.020
C	0.19	0.25	0.007	0.010
D	4.80	5.00	0.189	0.197
E	3.80	4.00	0.150	0.157
e	1.27		0.050	
H	5.80	6.20	0.228	0.244
L	0.40	1.27	0.016	0.050
Y	0.00	0.10	0.000	0.004
$\theta 1$	0°	8°	0°	8°

Note:

1. PACKAGE BODY SIZES EXCLUDE MOLD FLASH PROTRUSIONS OR GATE BURRS.
2. TOLERANCE 0.1000mm (4mil) UNLESS OTHERWISE SPECIFIED
3. COPLANARITY: 0.1000mm
4. DIMENSION L IS MEASURED IN GAGE PLANE.
5. CONTROLLING DIMENSION IS MILLIMETER; CONVERTED INCH DIMENSIONS ARE NOT NECESSARILY EXACT.

### TSSOP-8

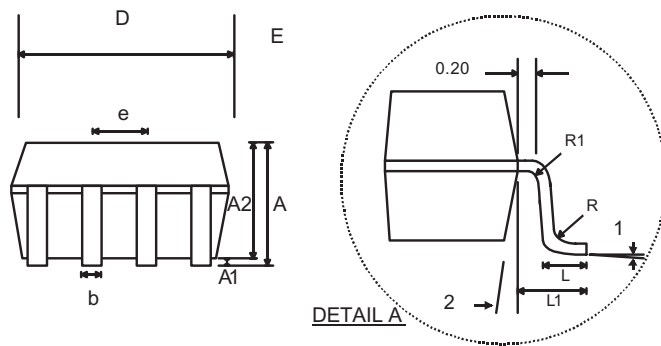
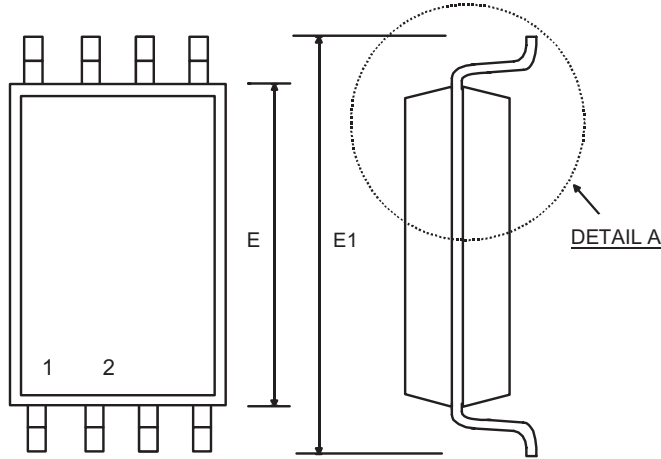

Dim	Millimeters		Inches	
	Min	Max	Min	Max
A	1.05	1.20	0.041	0.047
A1	0.05	0.15	0.002	0.006
A2	-	1.05	-	0.041
b	0.25	0.30	0.010	0.012
c	0.127		0.005	
D-8	2.90	3.10	0.114	0.122
D-28	9.60	9.80	0.378	0.386
E	4.30	4.50	0.170	0.177
E1	6.20	6.60	0.244	0.260
e	0.65 BSC		0.025 BSC	
L	0.50	0.70	0.20	0.028
L1	1.0		0.039	
R	0.09	-	0.004	-
R1	0.09	-	0.004	-
θ1	0°	8°	0°	8°
θ2	12°			