

PLL FREQUENCY SYNTHESIZER AND CONTROLLER FOR FM / MW / LW TUNER

The DMC 4002 is CMOS LSI chips developed for world-wide FM / MW / LW tuning with PLL frequency synthesizer system. The DMC 4002 can make a compact and high performance FM / MW / LW tuner with clock function for high-end car stereo, home stereo and so on because these CMOS LSIs are in 64-pin QFP package with built-in PLL frequency synthesizer, controller, 200 MHz prescaler, LCD driver and IF counter.

□ FUNCTIONS

RADIO FUNCTIONS

- (1) Manual tuning
Manual tuning up/down Stepped tuning and rapid tuning.
- (2) Auto tuning
Seek up/down Retaining the frequency of a station received.
Scan up/down Receiving in intervals of 5 seconds.
- (3) Preset memory scanning Receiving the contents of preset memories on the FM, MW, and LW bands for 5 seconds each.
- (4) VF auto - tuning
- SK seek up/down Retaining the frequency of a SK signal received.
SK scan up/down Receiving a station with SK signal in intervals of 5 seconds.
- (5) Preset memories
FM band FM 1 : 6 stations, FM 2 : 6 stations, FM 3 : 6 stations
MW band ... MW 1 : 6 stations, MW 2 : 6 stations
LW band ... 6 stations
VF band 6 stations
MW2 cannot be used while the LW band is used.
- (6) Last-preset memories1 station on the FM1, FM2, FM3, MW1, MW2, LW and VF bands each.
- (7) LOC (local) control signal outputs and indications.
- (8) FM MONO (monaural) control signal output and indication.(For VF bands, same as for FM)
- (9) "ST" (stereo) indicator Enabled on the FM and VF bands.
- (10) Auto-preset memories
- (11) DK stand-by and SK alarm function

TAPE FUNCTIONS

- (1) Tape transport direction indicators Can flash at 2 Hz during fast forward.
- (2) AMS (auto music search) control signal output and indication.
- (3) MTL (metal) control signal output and indication.
- (4) NR1 (noise reduction) and NR2 control outputs and indications.

□ FUNCTIONS (continued)

CLOCK FUNCTIONS

- (1) Selectable 12-hour(with AM and PM indicators) or 24-hour display.
- (2) Selectable flashing colon(:) (1Hz).
- (3) Low-power (400nA) backup available in the NOCLK(no-clock)mode.

OTHERS

- (1) LOUD (loudness) control signal output and indication common to radio, tape, and CD modes.
- (2) Key acknowledge(beep) signal outputs (2.25 kHz, 40ms) Enabled by valid momentary keys.
- (3) Display selector and priority display function.
- (4) "CD" (compact disk) indicator.

Table) Receiving frequency, channel spacing, reference frequency, intermediate frequency

| AREA | ITEM BAND | RECEIVING FREQUENCY | CHANNEL SPACE | REFERENCE FREQUENCY | INTERMEDIATE FREQUENCY |
|------------------------------------|-----------|---------------------|---------------|---------------------|------------------------|
| Europe 1 | FM | 87.5 to 108.0 MHz | 50kHz | 25kHz | 10.7MHz |
| | MW | 522 to 1620 kHz | 9kHz | 9kHz | 450kHz |
| | LW | 144 to 281kHz | 1kHz | 1kHz | 450kHz |
| Europe 2 | FM | 87.5 to 108.0 MHz | 50kHz | 25kHz | 10.7MHz |
| | MW | 522 to 1620 kHz | 9kHz | 9kHz | 459kHz |
| | LW | 144 to 281kHz | 1kHz | 1kHz | 459kHz |
| U.S.A 1 | FM | 87.5 to 108.0 MHz | 100kHz | 25kHz | 10.7MHz |
| | MW | 530 to 1620 kHz | 10kHz | 10kHz | 450kHz |
| U.S.A 2 | FM | 87.5 to 107.9 MHz | 200kHz | 25kHz | 10.7MHz |
| | MW | 530 to 1620 kHz | 10kHz | 10kHz | 450kHz |
| U.S.A 3 | FM | 87.5 to 107.9 MHz | 200kHz | 25kHz | 10.7MHz |
| | MW | 530 to 1710 kHz | 10kHz | 10kHz | 450kHz |
| Australia and Middle and Near East | FM | 87.5 to 108.0 MHz | 100kHz | 25kHz | 10.7MHz |
| | MW | 531 to 1602 kHz | 9kHz | 9kHz | 450kHz |
| Japan | FM | 76.0 to 90.0 MHz | 100kHz | 25kHz | - 10.7MHz |
| | MW | 522 to 1629 kHz | 9kHz | 9kHz | 450kHz |
| Latin America | FM | 87.5 to 108.0 MHz | 100kHz | 25kHz | 10.7MHz |
| | MW | 520 to 1620 kHz | 5kHz | 5kHz | 450kHz |

□ FEATURES

- Single power supply of $5V \pm 10\%$
- Built-in prescaler (200 MHz MAX. $V_{in} = 0.3 V_{p-p}$), IF counter and LCD driver (1/2 duty, 1/2 bias, frame frequency: 100Hz)
- Capable of receiving FM and MW in the whole world and LW in Europe.
- Tuning function..... Manual tuning, auto-tuning (seek and scan) and preset memory scan.
- Independent preset memory programming by six buttons for up to 18 FM stations (six FM1, FM2 and FM3 stations each), up to 12 MW stations (six MW1 and MW2 stations each), up to six LW stations and VF broadcasting stations.
- Each last channel memory for FM : 3, MW : 1 and VF : 1
- VF auto-tuning (SK signal search) with DK stand-by function.
- Control output of MONO and LOC (LOCAL / DX) and its display.
- Stereo display (ST)
- Control output of MTL (METAL), NR1 (NOISE REDUCTION), NR2 and AMS (AUTO MUSIC SEARCH) and its display.
- Automatic preset station memory function
- Compact disc display ()
- Loudness control output and its display
- Built-in 12 hour/24 hour clock display function (possible to set no clock)

□ PIN CONFIGURATION

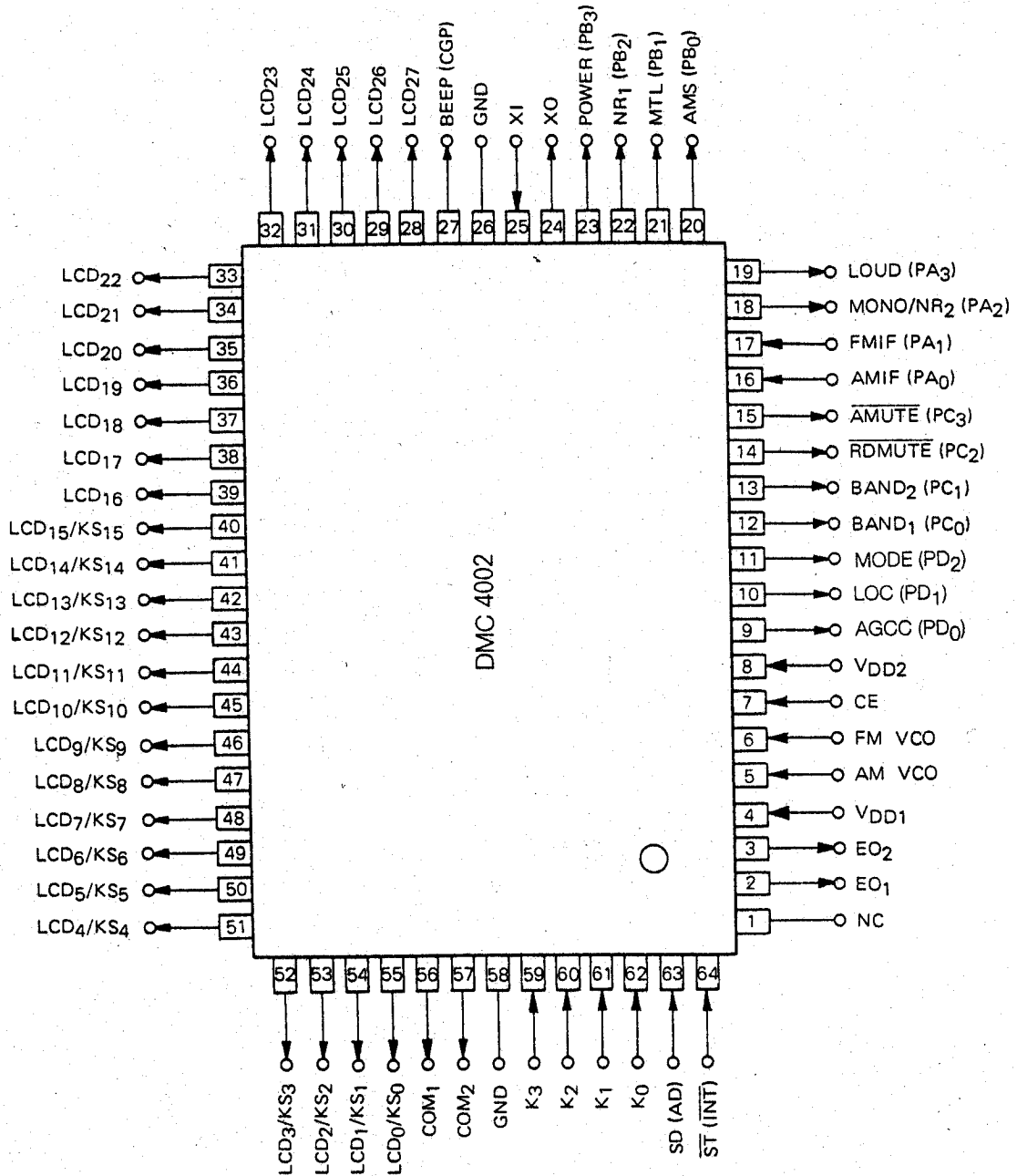

□ CONTENTS

| | |
|---|----|
| 1. PIN DESCRIPTION | 6 |
| 2. KEY MATRIX | 15 |
| 2.1 KEY MATRIX LAYOUT | 15 |
| 2.2 SWITCH CONNECTION | 15 |
| 2.3 KEY MATRIX CONNECTION | 16 |
| 2.4 DESCRIPTION OF KEY MATRIX | 17 |
| 3. MODE TRANSITION | 51 |
| 3.1 WHEN THE INITIALIZED DIODE RDON=1(RADIO ON/OFF BY CE PIN) | 51 |
| 3.2 RADIO ON/OFF BY RDSET SWITCH | 53 |
| 3.3 DESCRIPTION OF EACH MODE | 55 |
| 3.4 RADIO ON/OFF BY POWER KEY | 56 |
| 4. DISPLAY | 57 |
| 4.1 LCD PANEL | 57 |
| 4.2 DISPLAY TYPE | 57 |
| 4.3 SEGMENT LINES | 57 |
| 4.4 COMMON LINES | 57 |
| 4.5 LCD ASSIGNMENT TABLE | 58 |
| 4.6 DESCRIPTION OF DISPLAYS | 59 |
| 5. RADIO MUTE OUTPUT TIMING (<u>RDMUTE</u>) | 61 |
| 5.1 RADIO MUTE (<u>RDMUTE</u> PIN) OUTPUT TIMING CHARTS | 61 |
| 5.2 RADIO MUTE (<u>RDMUTE</u> PIN) AND AUDIO MUTE (<u>AMUTE</u> PIN) OUTPUT TIMING CHARTS | 65 |
| 6. PIN I/O CIRCUITS | 67 |
| 7. APPLICATION CIRCUITS | 69 |
| 7.1 POWER ON/OFF (NO CLOCK DISPLAY AT POWER OFF) BY ALTERNATE SWITCH | 69 |
| 7.2 POWER ON/OFF (CLOCK DISPLAY AT POWER OFF) BY ALTERNATE SWITCH | 70 |
| 7.3 POWER ON/OFF (CLOCK DISPLAY AT POWER OFF) BY MOMENTARY SWITCH | 71 |
| 8. ELECTRICAL SPECIFICATIONS | 72 |
| 9. PACKAGE DIMENSION | 74 |



1. PIN DESCRIPTION

| PIN No. | SYMBOL | FUNCTION | DESCRIPTION | OUTPUT TYPE |
|----------|--------------------------------------|----------------------------|---|-----------------|
| 1 | NC | No connection | This pin is not connected to the internal chip. Therefore, leave it open or connect it to GND, V _{DD} , etc. | — |
| 2 3 | EO ₁ EO ₂ | Error out | <p>PLL (Phase Locked Loop) error output pins.</p> <p>When the frequency obtained by dividing the local oscillation frequency (VCO output) is higher than the reference frequency. High level is output from these pins. When it is lower than the reference frequency.</p> <p>Low level is output from these pins. When the two frequencies are the same, these pins are floated.</p> <p>This output is input to an external LPF (Low Pass Filter) and is applied to a varactor diode through the LPF. EO₁ and EO₂ output the same waveform so that the pin to be used can be freely selected. When the radio is OFF, these pins are floated.</p> | CMOS 3-state |
| 4 - 8 | V _{DD1} V _{DD2} | Power supply input | <p>Device power supply input pin.</p> <p>This pin supplies 5V ± 10% power voltage during device operation (radio, tape, and CD modes). When the diode matrix NOCLK switch is 1 (shorted by diode), when the CE pin (pin 7) is made Low level, this pin drops to 2.5V and data hold is enabled. When a voltage of 0 → 4.5V is supplied to this pin, the data is initialized.</p> <p>Supply 0 → 4.5V to this pin within 500 ms.</p> <p>Always connect pins 4 and 8 to the same potential. V_{DD1}(pin 4) is the analog system (PLL, A/D converter, INT, CE) power supply and V_{DD2}(pin 8) is the digital system (CPU, LCD driver, IF counter) power supply.</p> | — |
| 5 | AM | AM local oscillation input | <p>The AM (MW and LW band) local oscillation output (VCO output) is input to this pin. When the radio is turned on and the MW or LW band is received, this pin becomes active. Otherwise, it is pulled down internally.</p> <p>The input amplitude is 0.3 V_{P-P} MIN.</p> <p>Since there is an on-chip AC amplifier, block the DC component with a capacitor.</p> | Input |
| 6 | FM | FM local oscillation input | <p>The FM local oscillation output (VCO output) is input to this pin.</p> <p>When the radio is turned on and the FM band is received, this pin becomes active. Otherwise, it is pulled down internally.</p> <p>The input amplitude is 0.3 V_{P-P} MIN.</p> <p>Since there is an on-chip AC amplifier, block the DC component of the input signal with a capacitor.</p> | Input |

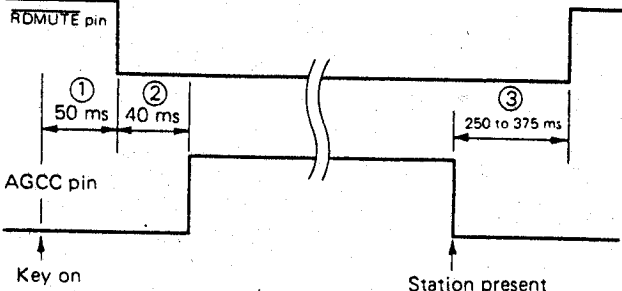

| PIN No. | SYMBOL | FUNCTION | DESCRIPTION | OUTPUT TYPE |
|---------|--------|----------------|--|---------------|
| 7 | CE | Chip enable | <p>Device select signal input pin.</p> <p>When the device is operated normally (radio, tape, CD, clock display, etc.), High level is input and when the device is not used, Low level is input.</p> <p>However, High and Low levels of 134μs or less are not accepted.</p> <p>When this pin is Low level, the radio, tape, CD and display are turned off and the device enters the data hold state.</p> <p>At this time, data hold at low consumption current (400nA or less) is possible by setting the NOCLK switch of the diode matrix to be described later to 1 (shorted by diode, no-clock mode.)</p> | Input |
| 9 | AGCC | AGC cut output | <p>Radio mode AGC(AUTOMATIC GAIN CONTROL) cut signal output pin.</p> <p>During autotuning, the High level shown below is output.</p>  <p>① Key on chattering wait ② Pre-muting ③ Post-muting</p> | CMOS pushpull |
| 10 | LOC | Local output | <p>This pin works as a LOCAL signal output pin when in the radio mode.</p> <p>The output is inverted each time <input type="checkbox"/> LOC key is pressed. When the LOCAL state is enabled with <input type="checkbox"/> LOC key, the "LOC" indicator on the LCD panel turns on, with an output high on this pin.</p> <p>The local state can be set in common on FM, VF, MW and LW bands.</p> <p>This pin is low at power-on time.</p> | CMOS pushpull |

| PIN No. | SYMBOL | FUNCTION | DESCRIPTION | OUTPUT TYPE | | | | | | | | | | | | | | | | | | | | | |
|---|-----------------|------------------------------|--|-------------|-------|----------|----|------------------------------------|---|------------|---|-----------|----|---------|---|---|---|--------------------|------------|---------------|-------------|----|---|---|---------------|
| 11 | MODE | Mode signal output | <p>Mode switching signal output pin. Its output in each mode is shown below.</p> <table border="1"> <thead> <tr> <th>Mode</th> <th>MODE</th> </tr> </thead> <tbody> <tr> <td>CE = Low</td> <td>0</td> </tr> <tr> <td>CE = High ; radio, tape and CD OFF</td> <td>0</td> </tr> <tr> <td>Radio mode</td> <td>1</td> </tr> <tr> <td>Tape mode</td> <td>0</td> </tr> <tr> <td>CD mode</td> <td>0</td> </tr> <tr> <td>Tape DK standby CD DK standby DK ON</td> <td>1</td> </tr> <tr> <td>Radio monitor mode</td> <td>1</td> </tr> </tbody> </table> <p>(0:Low level, 1:High level)</p> <p>That is, when the PLL is operated, High level is output from this pin. Therefore, use it to turn the tuner power on/off, etc.</p> | Mode | MODE | CE = Low | 0 | CE = High ; radio, tape and CD OFF | 0 | Radio mode | 1 | Tape mode | 0 | CD mode | 0 | Tape DK standby CD DK standby DK ON | 1 | Radio monitor mode | 1 | CMOS pushpull | | | | | |
| Mode | MODE | | | | | | | | | | | | | | | | | | | | | | | | |
| CE = Low | 0 | | | | | | | | | | | | | | | | | | | | | | | | |
| CE = High ; radio, tape and CD OFF | 0 | | | | | | | | | | | | | | | | | | | | | | | | |
| Radio mode | 1 | | | | | | | | | | | | | | | | | | | | | | | | |
| Tape mode | 0 | | | | | | | | | | | | | | | | | | | | | | | | |
| CD mode | 0 | | | | | | | | | | | | | | | | | | | | | | | | |
| Tape DK standby CD DK standby DK ON | 1 | | | | | | | | | | | | | | | | | | | | | | | | |
| Radio monitor mode | 1 | | | | | | | | | | | | | | | | | | | | | | | | |
| 12 13 | BAND1, BAND2 | Band switching signal output | <p>Radio mode band switching signal output pin. Its operation is described below.</p> <ul style="list-style-type: none"> - Radio mode <p>When the receiving band is switched by band switching key, the following is output on each band:</p> <table border="1"> <thead> <tr> <th>BAND \ Pin</th> <th>BAND1</th> <th>BAND2</th> </tr> </thead> <tbody> <tr> <td>MW</td> <td>0</td> <td>0</td> </tr> <tr> <td>LW</td> <td>0</td> <td>1</td> </tr> <tr> <td>FM</td> <td>1</td> <td>0</td> </tr> <tr> <td>VF</td> <td>1</td> <td>1</td> </tr> </tbody> </table> <p>(0:Low level, 1:High level)</p> <ul style="list-style-type: none"> - DK standby mode - DK ON mode <table border="1"> <thead> <tr> <th>BAND \ Pin</th> <th>BAND1</th> <th>BAND2 /OPT.</th> </tr> </thead> <tbody> <tr> <td>VF</td> <td>1</td> <td>1</td> </tr> </tbody> </table> <ul style="list-style-type: none"> - Radio monitor mode Same as radio mode. - Tape mode - CD mode Low level output | BAND \ Pin | BAND1 | BAND2 | MW | 0 | 0 | LW | 0 | 1 | FM | 1 | 0 | VF | 1 | 1 | BAND \ Pin | BAND1 | BAND2 /OPT. | VF | 1 | 1 | CMOS pushpull |
| BAND \ Pin | BAND1 | BAND2 | | | | | | | | | | | | | | | | | | | | | | | |
| MW | 0 | 0 | | | | | | | | | | | | | | | | | | | | | | | |
| LW | 0 | 1 | | | | | | | | | | | | | | | | | | | | | | | |
| FM | 1 | 0 | | | | | | | | | | | | | | | | | | | | | | | |
| VF | 1 | 1 | | | | | | | | | | | | | | | | | | | | | | | |
| BAND \ Pin | BAND1 | BAND2 /OPT. | | | | | | | | | | | | | | | | | | | | | | | |
| VF | 1 | 1 | | | | | | | | | | | | | | | | | | | | | | | |

| PIN No. | SYMBOL | FUNCTION | DESCRIPTION | OUTPUT TYPE |
|---------|----------------------------|-------------------|---|---------------|
| 14 | $\overline{\text{RDMUTE}}$ | Radio mute output | <p>Radio mute signal output pin.</p> <p>This pin operates as follows:</p> <ul style="list-style-type: none"> - Radio mode Low level is output at radio ON/OFF, band switching, and receiving frequency switching. - Tape and CD modes High level or Low level can be selected by MUTESEL switch of the diode matrix to be described later. <p>However, when using the DK standby or radio monitor function, set the MUTESEL switch to 0 and select low level output.</p> <p>For more information, see "Mute Output Timing Chart".</p> | CMOS pushpull |
| 15 | $\overline{\text{AMUTE}}$ | Audio mute output | <p>Tape and CD mute signal output pin at DK ON and radio monitor ON.</p> <p>In the radio mode, Low level is output and in the tape and CD modes, High level is output. When DK is turned on during DK standby and in the radio monitor mode, Low level is output.</p> <p>For more information, see "Mute Output Timing Chart".</p> | CMOS pushpull |



| PIN No. | SYMBOL | FUNCTION | DESCRIPTION | OUTPUT TYPE | | | | | | | | | | | | | | | | |
|------------------|------------------------------|---------------------------------|---|------------------|------------------------------|------------------------------|-----------|------------------|--------------------|-------|-----------|----------|----|---------|----|-----------|--------|----|-----------|-------|
| 16 | AM IF | AM intermediate frequency input | <p>AM (MW and LW bands) intermediate frequency (IF) input pin.</p> <p>The input amplitude is 0.1 V_{p-p}. Since there is an on-chip AC amplifier, block the DC component of the input signal with a capacitor. This pin is valid when the initialized diode matrix DISAMIF switch is 0.</p> <p>This pin is used for detecting the presence of a broadcast station during MW and LW band autotuning. The input frequency ranges and input conditions for determining the presence of a broadcast station are shown below.</p> <table border="1" data-bbox="628 658 1241 944"> <thead> <tr> <th>Area \ Item Band</th> <th>Input Frequency Range ①(kHz)</th> <th>Input Frequency Range ②(kHz)</th> </tr> </thead> <tbody> <tr> <td rowspan="2">Europe 1</td> <td>MW</td> <td>450 ± 5</td> </tr> <tr> <td>LW</td> <td>450 ± 0.5</td> </tr> <tr> <td rowspan="2">Europe 2</td> <td>MW</td> <td>459 ± 5</td> </tr> <tr> <td>LW</td> <td>459 ± 0.5</td> </tr> <tr> <td>Others</td> <td>MW</td> <td>450 ± 0.5</td> </tr> </tbody> </table> <p>Input frequency range ① is the frequency that must be input within 20 ms after the PLL is locked.</p> <p>Input frequency range ② is the frequency that must be input within 40 ms after ① was input.</p> <p>When both input frequency ranges ① and ② are satisfied, a broadcast station is judged to be present and autotuning stops.</p> | Area \ Item Band | Input Frequency Range ①(kHz) | Input Frequency Range ②(kHz) | Europe 1 | MW | 450 ± 5 | LW | 450 ± 0.5 | Europe 2 | MW | 459 ± 5 | LW | 459 ± 0.5 | Others | MW | 450 ± 0.5 | Input |
| Area \ Item Band | Input Frequency Range ①(kHz) | Input Frequency Range ②(kHz) | | | | | | | | | | | | | | | | | | |
| Europe 1 | MW | 450 ± 5 | | | | | | | | | | | | | | | | | | |
| | LW | 450 ± 0.5 | | | | | | | | | | | | | | | | | | |
| Europe 2 | MW | 459 ± 5 | | | | | | | | | | | | | | | | | | |
| | LW | 459 ± 0.5 | | | | | | | | | | | | | | | | | | |
| Others | MW | 450 ± 0.5 | | | | | | | | | | | | | | | | | | |
| 17 | FM IF | FM intermediate frequency input | <p>FM band intermediate frequency (IF) input.</p> <p>The input amplitude is 0.1 V_{p-p}. Since there is an AC amplifier on the chip, block the DC component of the input signal with a capacitor. This pin is valid when the initialized diode matrix switch ENFMIF is 1.</p> <p>This pin is used for detecting the presence of a broadcast station during FM band autotuning. The input frequency ranges and input conditions for determining the presence of a broadcast station are shown below.</p> <table border="1" data-bbox="634 1520 1244 1641"> <thead> <tr> <th>Area \ Item</th> <th>Input Frequency Range ①</th> <th>Input Frequency Range ②</th> </tr> </thead> <tbody> <tr> <td>All areas</td> <td>10.7 MHz ± 50kHz</td> <td>10.7 MHz ± 12.5kHz</td> </tr> </tbody> </table> <p>Input frequency range ① is the frequency that must be input within 20 ms after the PLL is locked.</p> <p>Input frequency range ② is the frequency that must be input within 20 ms after ① was input.</p> <p>When both input frequency ranges ① and ② are satisfied, a broadcast station is judged to be present and autotuning stops.</p> | Area \ Item | Input Frequency Range ① | Input Frequency Range ② | All areas | 10.7 MHz ± 50kHz | 10.7 MHz ± 12.5kHz | Input | | | | | | | | | | |
| Area \ Item | Input Frequency Range ① | Input Frequency Range ② | | | | | | | | | | | | | | | | | | |
| All areas | 10.7 MHz ± 50kHz | 10.7 MHz ± 12.5kHz | | | | | | | | | | | | | | | | | | |

| PIN NO. | SYMBOL | FUNCTION | DESCRIPTION | OUTPUT TYPE |
|---------|----------------------|-------------------------------------|---|---------------|
| 18 | MONO/NR ₂ | Monaural and noise reduction output | <p>In the radio mode, this pin operates as the MONO signal output pin and in the tape mode, this pin operates as the NOISE REDUCTION signal output pin.</p> <p>- Radio mode Each time the <input type="checkbox"/> MONO key is pressed on the FM and VF bands, the output is inverted. When the device is set to the MONO state by <input type="checkbox"/> MONO key, the LCD panel "MONO" display lights and high level is output from this pin. On the MW and LW bands, this pin becomes low. When the power is turned on, this pin becomes low.</p> <p>- Tape mode This pin is valid when the diode matrix ENNR₂ switch to be described later is 1. When NOISE REDUCTION NR₂ is selected by pressing the <input type="checkbox"/> NR key or NOISE REDUCTION function key (selected by diode matrix), high level is output. At this time, the LCD panel "NR₂" display lights. When the power is turned on, this pin becomes low.</p> | CMOS pushpull |
| 19 | LOUD | LOUD output | <p>LOUDNESS signal output pin.</p> <p>In the radio, tape and CD modes, the output is inverted each time the <input type="checkbox"/> LOUD key is pressed. When the LOUDNESS state is selected by <input type="checkbox"/> LOUD key, the LCD panel "LOUD" display lights and high level is output from this pin. When the power is turned on, this pin becomes low.</p> | CMOS pushpull |
| 20 | AMS | AMS signal output | <p>Tape mode AMS(AUTO MUSIC SEARCH) control signal output pin.</p> <p>Its output is inverted each time the <input type="checkbox"/> AMS key is pressed. High level is output while the LCD panel "AMS" display is lit.</p> | CMOS pushpull |



| PIN No. | SYMBOL | FUNCTION | DESCRIPTION | OUTPUT TYPE |
|----------|----------|------------------------|---|---------------------|
| 21 | MTL | Metal output | <p>Tape mode metal signal output pin.</p> <p>Its output is inverted each time the <input type="checkbox"/> MTL key and METAL function key (selected by diode matrix) is pressed. When the METAL state is selected with these keys, the LCD panel "MTL" display lights and high level is output from this pin.</p> <p>When the power is turned on, this pin becomes low.</p> | CMOS pushpull |
| 22 | NR1 | Noise reduction output | <p>Tape mode noise reduction (NR) signal output pin.</p> <p>When NR1 is selected by the <input type="checkbox"/> NR key or NOISE REDUCTION function key (selected by diode matrix), the LCD panel "NR1" display lights and high level is output from this pin.</p> | CMOS pushpull |
| 23 | POWER | Power output | <p>When the CE pin is high level, the output of this pin is inverted each time the <input type="checkbox"/> POWER key is pressed.</p> <p>When the power is turned on, low level is output.</p> <p>This pin can be used to turn the set power on and off, etc. See "Application Circuits".</p> | CMOS pushpull |
| 24 25 | XO XI | Crystal oscillator | <p>Crystal oscillator connection pin. It connects to a 4.5 MHz crystal oscillator.</p> <p>When the clock function is used, the accuracy of the clock is effected by the oscillation frequency accuracy only.</p> <p>Adjust the oscillation frequency while observing the LCD oscillation waveform and PLL local oscillation frequency.</p> | CMOS (XO) Input(XI) |
| 26 28 | GND | Ground | <p>Device ground pins.</p> <p>These pins connect to the internal chip. Therefore one of these two should be a ground. (Not all these two should not be.)</p> | |



| PIN No. | SYMBOL | FUNCTION | DESCRIPTION | OUTPUT TYPE |
|--------------------------------------|--|-----------------------------------|--|---------------|
| 27 | BEEP | Beep output | <p>Beep output pin when momentary key pressed. A 2.25 kHz and 50% duty square wave is output for approximately 40 ms. This time is equal to the premuting time.</p> <p>When a momentary key is pressed and the state of the LCD panel display or output port is changed (valid key) and at the end of 5 seconds hold during preset memory scan and scan operations, a beep is output.</p> <p>To disable the beep, float (leave open) this pin.</p> <p>The beep output is also used at SK alarm at DK standby.</p> | CMOS pushpull |
| 28 to 39 40 to 55 | LCD ₂₇ to LCD ₁₆ LCD ₁₅ /KS ₁₅ to LCD ₀ /KS ₀ | LCD segment and key source output | <p>LCD panel segment signal output (pins 28 to 55) and key matrix key source signal output (pins 40 to 55) pins.</p> <p>56-dot display is performed at the LCD panel by matrix with the COM₁ pin(pin 56) and COM₂ pin (pin 57).</p> <p>Since LCD₁₅ / KS₁₅(pin 40) to LCD₀ / KS₀(pin 55) share the key source signal and LCD segment signal, to use them as key source signals, a reverse current prevention diode is necessary. For the connection method, see "Key Matrix Connection" and "Application Circuits".</p> | CMOS pushpull |
| 56 57 | COM ₁ COM ₂ | LCD common signal output | <p>Common signal output to LCD panel.</p> <p>56-dot display is performed at the LCD panel by matrix with LCD₂₇(pin 28) to LCD₀/KS₀(pin 55)</p> | CMOS pushpull |
| 59 to 62 | K ₃ to K ₀ | Key return signal input | <p>Key matrix key return signal input pin.</p> <p>Since the key source signal output is shared with the LCD segment signal, do not connect a pull-down resistor to this pin.</p> | CMOS pushpull |

| PIN No. | SYMBOL | FUNCTION | DESCRIPTION | OUTPUT TYPE | | | | | | | | | | | | | | | | | | | | | | | | | | | | | | | | | | | | | | | | | | | | |
|---------|------------------------|---|---|-------------|------------|------------|----------------------|----|-------|---|--------|----|---|--------|----|-------|---|--------|----|----|---|--------|------|------------|------------|----------------------|----|------------------|---|--------|------------------|---|--------|---------------|---|--------|----|------------------|---|--------|------------------|---|--------|----|---------------|---|--------|-------|
| 63 | SD | SD input | <p>Autotuning SD (Station Detector) signal input pin. When the voltage shown below is applied to this pin during the seek operation, a broadcast station is judged to be present.</p> <table border="1"> <thead> <tr> <th>Band</th> <th>LOCAL Mode</th> <th>SD Voltage</th> <th>V_{DD} = 5V</th> </tr> </thead> <tbody> <tr> <td rowspan="2">FM</td> <td>LOCAL</td> <td>$\frac{28.5}{64} \times V_{DD \text{ min}}$</td> <td>2.227V</td> </tr> <tr> <td>DX</td> <td>$\frac{12.5}{64} \times V_{DD \text{ min}}$</td> <td>0.977V</td> </tr> <tr> <td>MW</td> <td>LOCAL</td> <td>$\frac{15.5}{64} \times V_{DD \text{ min}}$</td> <td>1.211V</td> </tr> <tr> <td>LW</td> <td>DX</td> <td>$\frac{12.5}{64} \times V_{DD \text{ min}}$</td> <td>0.977V</td> </tr> </tbody> </table> <p>In the auto preset memory mode, search is performed twice in the LOCAL mode and once in the DX mode. The voltage to determine the presence of a broadcast station at this time is shown below.</p> <table border="1"> <thead> <tr> <th>Band</th> <th>LOCAL Mode</th> <th>SD Voltage</th> <th>V_{DD} = 5V</th> </tr> </thead> <tbody> <tr> <td rowspan="3">FM</td> <td>LOCAL (1st time)</td> <td>$\frac{44.5}{64} \times V_{DD \text{ min}}$</td> <td>3.447V</td> </tr> <tr> <td>LOCAL (2nd time)</td> <td>$\frac{28.5}{64} \times V_{DD \text{ min}}$</td> <td>2.227V</td> </tr> <tr> <td>DX (3rd time)</td> <td>$\frac{12.5}{64} \times V_{DD \text{ min}}$</td> <td>0.977V</td> </tr> <tr> <td rowspan="2">MW</td> <td>LOCAL (1st time)</td> <td>$\frac{18.5}{64} \times V_{DD \text{ min}}$</td> <td>1.445V</td> </tr> <tr> <td>LOCAL (2nd time)</td> <td>$\frac{15.5}{16} \times V_{DD \text{ min}}$</td> <td>1.211V</td> </tr> <tr> <td>LW</td> <td>DX (3rd time)</td> <td>$\frac{12.5}{64} \times V_{DD \text{ min}}$</td> <td>0.977V</td> </tr> </tbody> </table> <p>When using the IF count, a broadcast station is detected when a broadcast station is judged to be present by both IF and SD pins</p> | Band | LOCAL Mode | SD Voltage | V _{DD} = 5V | FM | LOCAL | $\frac{28.5}{64} \times V_{DD \text{ min}}$ | 2.227V | DX | $\frac{12.5}{64} \times V_{DD \text{ min}}$ | 0.977V | MW | LOCAL | $\frac{15.5}{64} \times V_{DD \text{ min}}$ | 1.211V | LW | DX | $\frac{12.5}{64} \times V_{DD \text{ min}}$ | 0.977V | Band | LOCAL Mode | SD Voltage | V _{DD} = 5V | FM | LOCAL (1st time) | $\frac{44.5}{64} \times V_{DD \text{ min}}$ | 3.447V | LOCAL (2nd time) | $\frac{28.5}{64} \times V_{DD \text{ min}}$ | 2.227V | DX (3rd time) | $\frac{12.5}{64} \times V_{DD \text{ min}}$ | 0.977V | MW | LOCAL (1st time) | $\frac{18.5}{64} \times V_{DD \text{ min}}$ | 1.445V | LOCAL (2nd time) | $\frac{15.5}{16} \times V_{DD \text{ min}}$ | 1.211V | LW | DX (3rd time) | $\frac{12.5}{64} \times V_{DD \text{ min}}$ | 0.977V | Input |
| Band | LOCAL Mode | SD Voltage | V _{DD} = 5V | | | | | | | | | | | | | | | | | | | | | | | | | | | | | | | | | | | | | | | | | | | | | |
| FM | LOCAL | $\frac{28.5}{64} \times V_{DD \text{ min}}$ | 2.227V | | | | | | | | | | | | | | | | | | | | | | | | | | | | | | | | | | | | | | | | | | | | | |
| | DX | $\frac{12.5}{64} \times V_{DD \text{ min}}$ | 0.977V | | | | | | | | | | | | | | | | | | | | | | | | | | | | | | | | | | | | | | | | | | | | | |
| MW | LOCAL | $\frac{15.5}{64} \times V_{DD \text{ min}}$ | 1.211V | | | | | | | | | | | | | | | | | | | | | | | | | | | | | | | | | | | | | | | | | | | | | |
| LW | DX | $\frac{12.5}{64} \times V_{DD \text{ min}}$ | 0.977V | | | | | | | | | | | | | | | | | | | | | | | | | | | | | | | | | | | | | | | | | | | | | |
| Band | LOCAL Mode | SD Voltage | V _{DD} = 5V | | | | | | | | | | | | | | | | | | | | | | | | | | | | | | | | | | | | | | | | | | | | | |
| FM | LOCAL (1st time) | $\frac{44.5}{64} \times V_{DD \text{ min}}$ | 3.447V | | | | | | | | | | | | | | | | | | | | | | | | | | | | | | | | | | | | | | | | | | | | | |
| | LOCAL (2nd time) | $\frac{28.5}{64} \times V_{DD \text{ min}}$ | 2.227V | | | | | | | | | | | | | | | | | | | | | | | | | | | | | | | | | | | | | | | | | | | | | |
| | DX (3rd time) | $\frac{12.5}{64} \times V_{DD \text{ min}}$ | 0.977V | | | | | | | | | | | | | | | | | | | | | | | | | | | | | | | | | | | | | | | | | | | | | |
| MW | LOCAL (1st time) | $\frac{18.5}{64} \times V_{DD \text{ min}}$ | 1.445V | | | | | | | | | | | | | | | | | | | | | | | | | | | | | | | | | | | | | | | | | | | | | |
| | LOCAL (2nd time) | $\frac{15.5}{16} \times V_{DD \text{ min}}$ | 1.211V | | | | | | | | | | | | | | | | | | | | | | | | | | | | | | | | | | | | | | | | | | | | | |
| LW | DX (3rd time) | $\frac{12.5}{64} \times V_{DD \text{ min}}$ | 0.977V | | | | | | | | | | | | | | | | | | | | | | | | | | | | | | | | | | | | | | | | | | | | | |
| 64 | $\overline{\text{ST}}$ | Stereo signal input | <p>Radio mode "ST" (STEREO) display input pin. When low level is input to this pin, the LCD panel "ST" display lights. This pin is valid only on the FM and VF bands. In the MONO mode, "ST" is not displayed.</p> | Input | | | | | | | | | | | | | | | | | | | | | | | | | | | | | | | | | | | | | | | | | | | | |

2. KEY MATRIX

2.1 KEY MATRIX LAYOUT

| Output Pin \ Input Pin | K ₃ (59) | K ₂ (60) | K ₁ (61) | K ₀ (62) |
|---|---------------------|---------------------|---------------------|---------------------|
| LCD ₁₅ / KS ₁₅ (40) | M1 (TP1) | M2 (TP2) | M3 (TP3) | M4 |
| LCD ₁₄ / KS ₁₄ (41) | M5 | M6 | VF | VF |
| LCD ₁₃ / KS ₁₃ (42) | SEEK DWN | SEEK UP | SCAN DWN | SCAN UP |
| LCD ₁₂ / KS ₁₂ (43) | BAND | — | — | — |
| LCD ₁₁ / KS ₁₁ (44) | ME(DISP) | MAN DWN | MAN UP | PSCAN AMEMO |
| LCD ₁₀ / KS ₁₀ (45) | LOUD | LOC(TP4) | MONO(TP5) | — |
| LCD ₉ / KS ₉ (46) | AMS | NR | MTL | RDMONI |
| LCD ₈ / KS ₈ (47) | — | — | — | DISP |
| LCD ₇ / KS ₇ (48) | CD SET | TP SET | RD SET | POWER |
| LCD ₆ / KS ₆ (49) | SK | DK | FF | RL |
| LCD ₅ / KS ₅ (50) | AUTO500 | MUTESEL | AUTOSTP | ENNR2 |
| LCD ₄ / KS ₄ (51) | KAMS | KNR | KMTL | ENTPK |
| LCD ₃ / KS ₃ (52) | NOCLK | CLK DISP | FLASH | DISAMEMO |
| LCD ₂ / KS ₂ (53) | ENFMIF | DISAMIF | PRIQ2 | PRIQ1 |
| LCD ₁ / KS ₁ (54) | DISFM3 | ENMW2 | DISLW | M2S |
| LCD ₀ / KS ₀ (55) | AREA3 | AREA2 | AREA1 | RDON |

() : Pin No

2.2 SWITCH CONNECTION

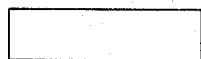

: Momentary switch



: Alternate or transistor switch



: Diode matrix

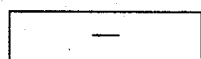

: Open

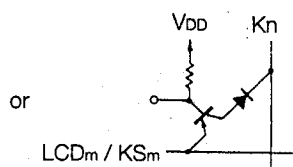
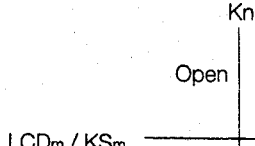
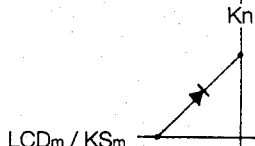
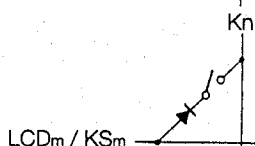
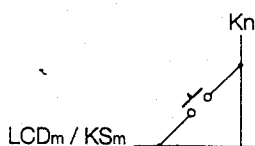

2.3 KEY MATRIX CONNECTION

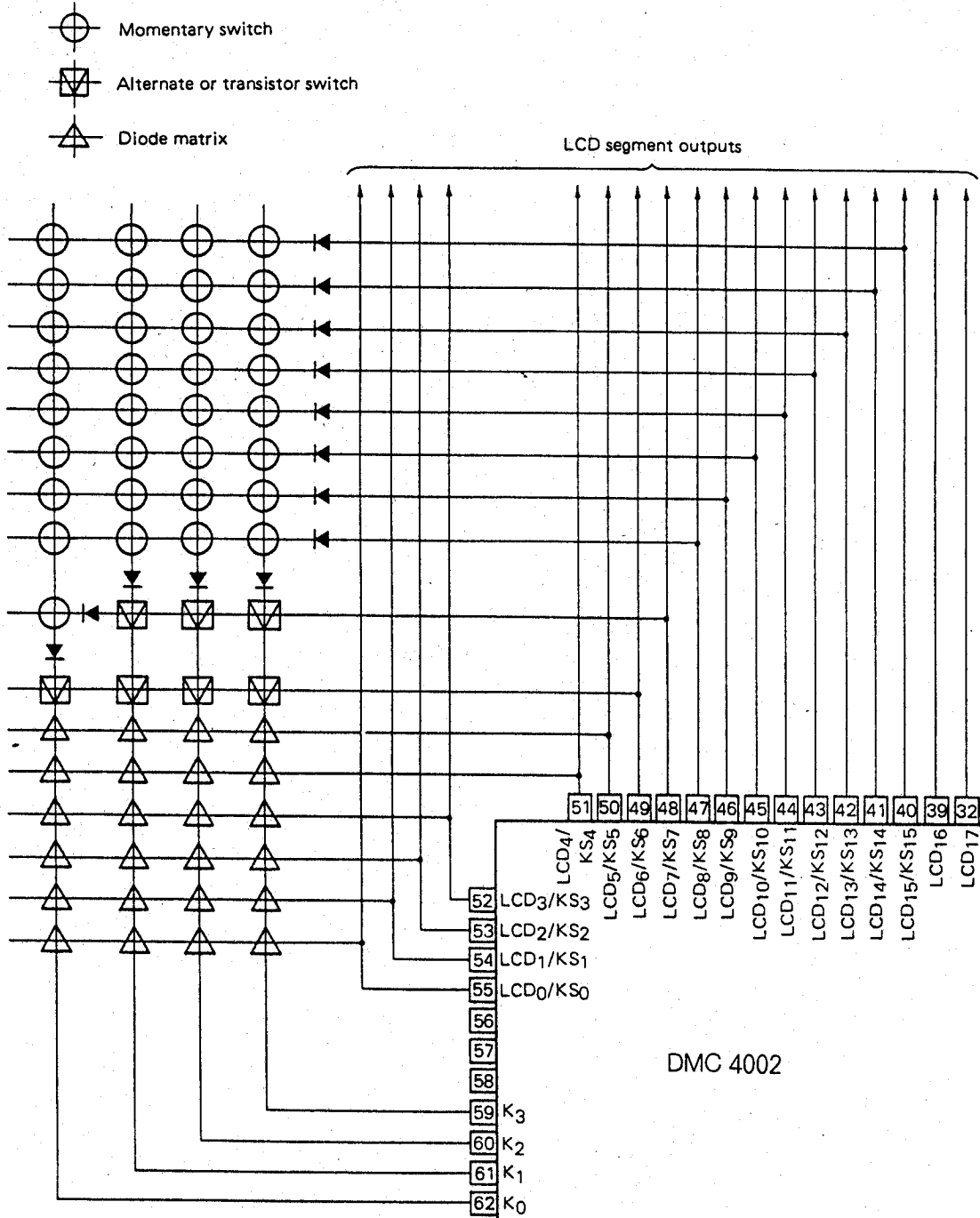

2.4 DESCRIPTION OF KEY MATRIX

2.4.1 Momentary Switch

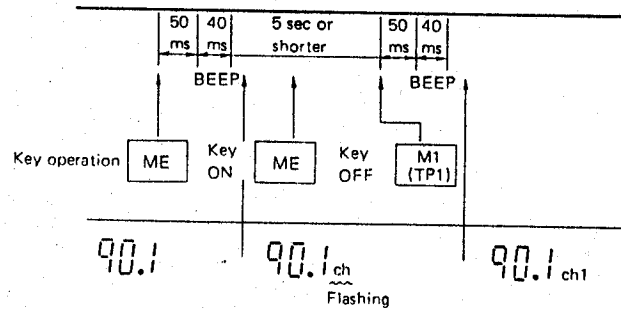
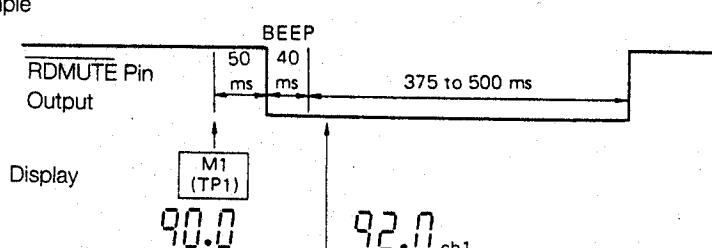
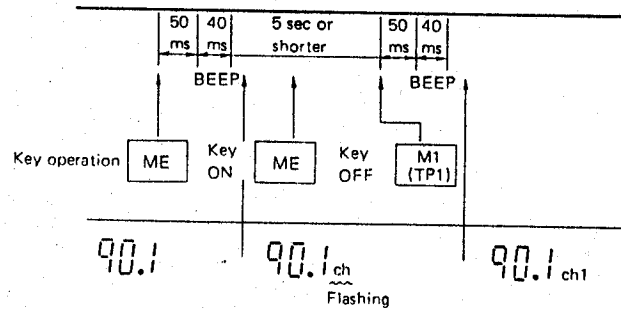
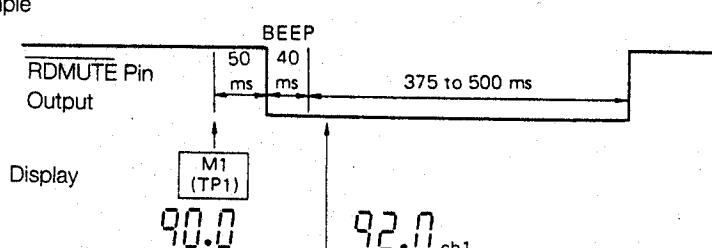
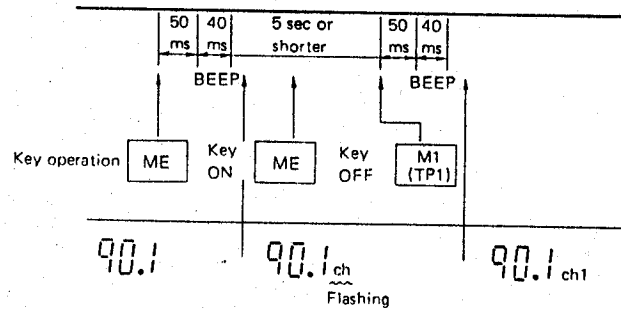
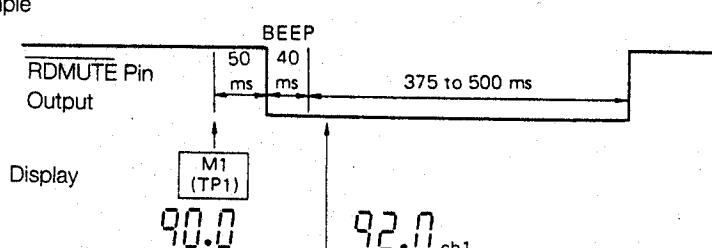
| Symbol | Function | | | | | | |
|--|--|-----|-------------|---|--|---|---|
| <p>M1(TP1)</p> <p>M2(TP2)</p> <p>M3(TP3)</p> <p>M4</p> <p>M5</p> <p>M6</p> | <p>In the radio mode, these keys are used to call and write preset memory. In the tape mode, these are used as tape function keys by initialized diode (ENTPK, KAMS, KNR, KMTL).</p> <p>- Radio mode</p> <p>Preset memory call and write keys.</p> <p>One key can memorize the FM1, FM2, FM3, VF, MW1, MW2 and LW bands independently (max. 6 bands).</p> <p>The following operations are performed according to the state of M2S of the initialized diodes :</p> <table border="1" data-bbox="334 602 1353 1328"> <thead> <tr> <th data-bbox="341 613 424 644">M2S</th> <th data-bbox="424 613 1345 644">Description</th> </tr> </thead> <tbody> <tr> <td data-bbox="341 644 424 1328">W</td> <td data-bbox="424 644 1345 1328"> <p>The device is placed into the 5 seconds preset memory write mode by pressing the ME key during frequency display. When one of the keys M1 (TP1) to M6 is pressed during this 5 seconds, the current receiving frequency is written to the preset memory corresponding to the pressed key.</p> <p>When the ME key is held down, writing is not performed. During writing, radio muting is not output.</p> <p>Example</p>  </td> </tr> <tr> <td data-bbox="341 1328 424 1887">C</td> <td data-bbox="424 1328 1345 1887"> <p>In the radio mode, when the device is in the memory unwritable state, when one of the M1 (TP1) to M6 keys is pressed, the preset memory contents corresponding to the pressed key can be called.</p> <p>Example</p>  </td> </tr> </tbody> </table> <p>When the same preset memory key is pressed while the current preset memory contents are being received, the same operation is performed.</p> <p>When the same preset memory key is pressed while the current preset memory contents are being received, no operation is performed. However, if the clock is being displayed. BEEP is output and the display switches to frequency display. Radio muting is not output.</p> | M2S | Description | W | <p>The device is placed into the 5 seconds preset memory write mode by pressing the ME key during frequency display. When one of the keys M1 (TP1) to M6 is pressed during this 5 seconds, the current receiving frequency is written to the preset memory corresponding to the pressed key.</p> <p>When the ME key is held down, writing is not performed. During writing, radio muting is not output.</p> <p>Example</p>  | C | <p>In the radio mode, when the device is in the memory unwritable state, when one of the M1 (TP1) to M6 keys is pressed, the preset memory contents corresponding to the pressed key can be called.</p> <p>Example</p>  |
| M2S | Description | | | | | | |
| W | <p>The device is placed into the 5 seconds preset memory write mode by pressing the ME key during frequency display. When one of the keys M1 (TP1) to M6 is pressed during this 5 seconds, the current receiving frequency is written to the preset memory corresponding to the pressed key.</p> <p>When the ME key is held down, writing is not performed. During writing, radio muting is not output.</p> <p>Example</p>  | | | | | | |
| C | <p>In the radio mode, when the device is in the memory unwritable state, when one of the M1 (TP1) to M6 keys is pressed, the preset memory contents corresponding to the pressed key can be called.</p> <p>Example</p>  | | | | | | |

| Symbol | Function |
|--|--|
| | <p>M2S Description</p> <p>When one of the key M1 (TP1) to M6 is pressed for more than 2 seconds, the preset memory corresponding to the pressed key is written. At the end of writing to the preset memory, radio muting is output as acknowledgment.</p> <p>When the same preset memory key is pressed while the current preset memory contents are being received, nothing is performed. However, if the clock is being displayed, BEEP is output when the key is released or after 2 seconds and the display switches to frequency display. At this time, radio muting is not output.</p> <p>If a key is pressed during the seek operation, the call operation is immediately performed (2 second count is ignored).</p> |
| <p>M1 (TP1)</p> <p>M2 (TP2)</p> <p>M3 (TP3)</p> <p>-M4</p> <p>M5</p> <p>M6</p> | <p>1</p> <p>When a M1 (TP1) to M6 key is pressed and released within 2 seconds, the contents of the preset memory is called as soon as the key is released.</p> <p>When the same preset memory key is pressed while the current preset memory contents are being received, nothing is performed. However, if the clock is being displayed, Beep is output and the display switches to frequency display. Radio muting is not output.</p> <p>If a key is pressed during the seek operation, the call operation is immediately performed.</p> |
| | <p>CALL</p> |

| Symbol | Function | | | | | | | | | | | | | | | | | | | | | | | | | | | | | | | | | | | | | | | | | | | | | | | | | | | | | | | | | | | | | | | | | | | | | | | | | | | | | | | | | | | | | | | | | | | | | | | | | | | | | | | | | | | | | | | | | | | | | | | | |
|-------------------------------------|--|------|-------------|------|------|-------|-------|------|----|----|------|------|----------------------|-----|----|------|------|------|------|-------|------|-----|--|-----|-----|-----|------|-----|-----|-----|--|-----|-----|------|------|-----|-----|--|----|--|-----|-----|-----|-----|-----|-----|-------------------------------------|-----|--|------|------|------|-------|------|------|-----|--|-----|-----|------|------|-----|-----|---------------------------|-----|--|------|------|------|-------|------|------|-----|--|-----|-----|-----|------|-----|-----|-------|-----|--|------|------|------|------|------|------|-----|--|-----|-----|-----|------|-----|-----|------------------------------|-----|--|------|------|------|-------|------|------|-----|--|-----|-----|-----|------|------|-----|--|--|--|--|--|--|--|
| | When the power is turned on, the frequency shown below are written to M1 to M6 to facilitate set adjustment. | | | | | | | | | | | | | | | | | | | | | | | | | | | | | | | | | | | | | | | | | | | | | | | | | | | | | | | | | | | | | | | | | | | | | | | | | | | | | | | | | | | | | | | | | | | | | | | | | | | | | | | | | | | | | | | | | | | | | | | | |
| | <table border="1"> <thead> <tr> <th rowspan="2">Area</th> <th colspan="2">Memory Band</th> <th rowspan="2">M1</th> <th rowspan="2">M2</th> <th rowspan="2">M3</th> <th rowspan="2">M4</th> <th rowspan="2">M5</th> <th rowspan="2">M6</th> </tr> <tr> <th>Band</th> <th>Band</th> </tr> </thead> <tbody> <tr> <td rowspan="3">Europe 1 Europe 2</td> <td>FM1</td> <td></td> <td>87.5</td> <td>87.7</td> <td>92.3</td> <td>96.3</td> <td>105.9</td> <td>87.5</td> </tr> <tr> <td>MW1</td> <td></td> <td>522</td> <td>603</td> <td>954</td> <td>1386</td> <td>522</td> <td>522</td> </tr> <tr> <td>MW2</td> <td></td> <td>522</td> <td>621</td> <td>1098</td> <td>1530</td> <td>522</td> <td>522</td> </tr> <tr> <td></td> <td>LW</td> <td></td> <td>144</td> <td>155</td> <td>208</td> <td>256</td> <td>144</td> <td>144</td> </tr> <tr> <td rowspan="2">U. S. A 1 U. S. A 2 U. S. A 3</td> <td>FM1</td> <td></td> <td>87.5</td> <td>87.9</td> <td>97.1</td> <td>105.1</td> <td>87.5</td> <td>87.5</td> </tr> <tr> <td>MW1</td> <td></td> <td>530</td> <td>620</td> <td>1010</td> <td>1490</td> <td>530</td> <td>530</td> </tr> <tr> <td rowspan="2">Australia, Middle East</td> <td>FM1</td> <td></td> <td>87.5</td> <td>87.9</td> <td>97.1</td> <td>105.1</td> <td>87.5</td> <td>87.5</td> </tr> <tr> <td>MW1</td> <td></td> <td>531</td> <td>612</td> <td>963</td> <td>1395</td> <td>531</td> <td>531</td> </tr> <tr> <td rowspan="2">Japan</td> <td>FM1</td> <td></td> <td>76.0</td> <td>76.4</td> <td>85.6</td> <td>76.0</td> <td>76.0</td> <td>76.0</td> </tr> <tr> <td>MW1</td> <td></td> <td>522</td> <td>603</td> <td>954</td> <td>1386</td> <td>522</td> <td>522</td> </tr> <tr> <td rowspan="2">Central and South America</td> <td>FM1</td> <td></td> <td>87.5</td> <td>87.9</td> <td>97.1</td> <td>105.1</td> <td>87.5</td> <td>87.5</td> </tr> <tr> <td>MW1</td> <td></td> <td>520</td> <td>565</td> <td>760</td> <td>1000</td> <td>1400</td> <td>520</td> </tr> </tbody> </table> | Area | Memory Band | | M1 | M2 | M3 | M4 | M5 | M6 | Band | Band | Europe 1 Europe 2 | FM1 | | 87.5 | 87.7 | 92.3 | 96.3 | 105.9 | 87.5 | MW1 | | 522 | 603 | 954 | 1386 | 522 | 522 | MW2 | | 522 | 621 | 1098 | 1530 | 522 | 522 | | LW | | 144 | 155 | 208 | 256 | 144 | 144 | U. S. A 1 U. S. A 2 U. S. A 3 | FM1 | | 87.5 | 87.9 | 97.1 | 105.1 | 87.5 | 87.5 | MW1 | | 530 | 620 | 1010 | 1490 | 530 | 530 | Australia, Middle East | FM1 | | 87.5 | 87.9 | 97.1 | 105.1 | 87.5 | 87.5 | MW1 | | 531 | 612 | 963 | 1395 | 531 | 531 | Japan | FM1 | | 76.0 | 76.4 | 85.6 | 76.0 | 76.0 | 76.0 | MW1 | | 522 | 603 | 954 | 1386 | 522 | 522 | Central and South America | FM1 | | 87.5 | 87.9 | 97.1 | 105.1 | 87.5 | 87.5 | MW1 | | 520 | 565 | 760 | 1000 | 1400 | 520 | | | | | | | |
| Area | Memory Band | | M1 | M2 | | | | | | | M3 | M4 | | M5 | M6 | | | | | | | | | | | | | | | | | | | | | | | | | | | | | | | | | | | | | | | | | | | | | | | | | | | | | | | | | | | | | | | | | | | | | | | | | | | | | | | | | | | | | | | | | | | | | | | | | | | | | | | | | | |
| | Band | Band | | | | | | | | | | | | | | | | | | | | | | | | | | | | | | | | | | | | | | | | | | | | | | | | | | | | | | | | | | | | | | | | | | | | | | | | | | | | | | | | | | | | | | | | | | | | | | | | | | | | | | | | | | | | | | | | | | | | | | | |
| Europe 1 Europe 2 | FM1 | | 87.5 | 87.7 | 92.3 | 96.3 | 105.9 | 87.5 | | | | | | | | | | | | | | | | | | | | | | | | | | | | | | | | | | | | | | | | | | | | | | | | | | | | | | | | | | | | | | | | | | | | | | | | | | | | | | | | | | | | | | | | | | | | | | | | | | | | | | | | | | | | | | | | | |
| | MW1 | | 522 | 603 | 954 | 1386 | 522 | 522 | | | | | | | | | | | | | | | | | | | | | | | | | | | | | | | | | | | | | | | | | | | | | | | | | | | | | | | | | | | | | | | | | | | | | | | | | | | | | | | | | | | | | | | | | | | | | | | | | | | | | | | | | | | | | | | | | |
| | MW2 | | 522 | 621 | 1098 | 1530 | 522 | 522 | | | | | | | | | | | | | | | | | | | | | | | | | | | | | | | | | | | | | | | | | | | | | | | | | | | | | | | | | | | | | | | | | | | | | | | | | | | | | | | | | | | | | | | | | | | | | | | | | | | | | | | | | | | | | | | | | |
| | LW | | 144 | 155 | 208 | 256 | 144 | 144 | | | | | | | | | | | | | | | | | | | | | | | | | | | | | | | | | | | | | | | | | | | | | | | | | | | | | | | | | | | | | | | | | | | | | | | | | | | | | | | | | | | | | | | | | | | | | | | | | | | | | | | | | | | | | | | | | |
| U. S. A 1 U. S. A 2 U. S. A 3 | FM1 | | 87.5 | 87.9 | 97.1 | 105.1 | 87.5 | 87.5 | | | | | | | | | | | | | | | | | | | | | | | | | | | | | | | | | | | | | | | | | | | | | | | | | | | | | | | | | | | | | | | | | | | | | | | | | | | | | | | | | | | | | | | | | | | | | | | | | | | | | | | | | | | | | | | | | |
| | MW1 | | 530 | 620 | 1010 | 1490 | 530 | 530 | | | | | | | | | | | | | | | | | | | | | | | | | | | | | | | | | | | | | | | | | | | | | | | | | | | | | | | | | | | | | | | | | | | | | | | | | | | | | | | | | | | | | | | | | | | | | | | | | | | | | | | | | | | | | | | | | |
| Australia, Middle East | FM1 | | 87.5 | 87.9 | 97.1 | 105.1 | 87.5 | 87.5 | | | | | | | | | | | | | | | | | | | | | | | | | | | | | | | | | | | | | | | | | | | | | | | | | | | | | | | | | | | | | | | | | | | | | | | | | | | | | | | | | | | | | | | | | | | | | | | | | | | | | | | | | | | | | | | | | |
| | MW1 | | 531 | 612 | 963 | 1395 | 531 | 531 | | | | | | | | | | | | | | | | | | | | | | | | | | | | | | | | | | | | | | | | | | | | | | | | | | | | | | | | | | | | | | | | | | | | | | | | | | | | | | | | | | | | | | | | | | | | | | | | | | | | | | | | | | | | | | | | | |
| Japan | FM1 | | 76.0 | 76.4 | 85.6 | 76.0 | 76.0 | 76.0 | | | | | | | | | | | | | | | | | | | | | | | | | | | | | | | | | | | | | | | | | | | | | | | | | | | | | | | | | | | | | | | | | | | | | | | | | | | | | | | | | | | | | | | | | | | | | | | | | | | | | | | | | | | | | | | | | |
| | MW1 | | 522 | 603 | 954 | 1386 | 522 | 522 | | | | | | | | | | | | | | | | | | | | | | | | | | | | | | | | | | | | | | | | | | | | | | | | | | | | | | | | | | | | | | | | | | | | | | | | | | | | | | | | | | | | | | | | | | | | | | | | | | | | | | | | | | | | | | | | | |
| Central and South America | FM1 | | 87.5 | 87.9 | 97.1 | 105.1 | 87.5 | 87.5 | | | | | | | | | | | | | | | | | | | | | | | | | | | | | | | | | | | | | | | | | | | | | | | | | | | | | | | | | | | | | | | | | | | | | | | | | | | | | | | | | | | | | | | | | | | | | | | | | | | | | | | | | | | | | | | | | |
| | MW1 | | 520 | 565 | 760 | 1000 | 1400 | 520 | | | | | | | | | | | | | | | | | | | | | | | | | | | | | | | | | | | | | | | | | | | | | | | | | | | | | | | | | | | | | | | | | | | | | | | | | | | | | | | | | | | | | | | | | | | | | | | | | | | | | | | | | | | | | | | | | |
| M1 (TP1) | | | | | | | | | | | | | | | | | | | | | | | | | | | | | | | | | | | | | | | | | | | | | | | | | | | | | | | | | | | | | | | | | | | | | | | | | | | | | | | | | | | | | | | | | | | | | | | | | | | | | | | | | | | | | | | | | | | | | | | | | |
| M2 (TP2) | | | | | | | | | | | | | | | | | | | | | | | | | | | | | | | | | | | | | | | | | | | | | | | | | | | | | | | | | | | | | | | | | | | | | | | | | | | | | | | | | | | | | | | | | | | | | | | | | | | | | | | | | | | | | | | | | | | | | | | | | |
| M3 (TP3) | | | | | | | | | | | | | | | | | | | | | | | | | | | | | | | | | | | | | | | | | | | | | | | | | | | | | | | | | | | | | | | | | | | | | | | | | | | | | | | | | | | | | | | | | | | | | | | | | | | | | | | | | | | | | | | | | | | | | | | | | |
| M4 | | | | | | | | | | | | | | | | | | | | | | | | | | | | | | | | | | | | | | | | | | | | | | | | | | | | | | | | | | | | | | | | | | | | | | | | | | | | | | | | | | | | | | | | | | | | | | | | | | | | | | | | | | | | | | | | | | | | | | | | | |
| M5 | | | | | | | | | | | | | | | | | | | | | | | | | | | | | | | | | | | | | | | | | | | | | | | | | | | | | | | | | | | | | | | | | | | | | | | | | | | | | | | | | | | | | | | | | | | | | | | | | | | | | | | | | | | | | | | | | | | | | | | | | |
| M6 | | | | | | | | | | | | | | | | | | | | | | | | | | | | | | | | | | | | | | | | | | | | | | | | | | | | | | | | | | | | | | | | | | | | | | | | | | | | | | | | | | | | | | | | | | | | | | | | | | | | | | | | | | | | | | | | | | | | | | | | | |
| | The lowest frequency of each area is M1 to M6 of the FM2, FM3, VF and MW2 bands of other than Europe 1 and 2. - Tape mode These keys can be used as tape function keys by means of initialized diode matrix switches ENTPK, KAMS and KMTL. For the keys that can be used, see the diode matrix. For a description of each key operation, see the <input type="text" value="AMS"/> , <input type="text" value="NR"/> and <input type="text" value="MTL"/> key items. | | | | | | | | | | | | | | | | | | | | | | | | | | | | | | | | | | | | | | | | | | | | | | | | | | | | | | | | | | | | | | | | | | | | | | | | | | | | | | | | | | | | | | | | | | | | | | | | | | | | | | | | | | | | | | | | | | | | | | | | |
| | VF(traffic information) broadcast station search key. Its operation is described below. When this key is pressed in the radio mode (FM, MW or LW band), the LCD panel "VF" display and Band2 pin output are inverted. When this key is pressed, the VF band is selected and 375 to 500 ms later, whether or not there is a broadcast station(IF count and SD check) and SK signal are detected. If no VF broadcast station is judged not to be present (The presence of a VF broadcast station is determined by the presence of an IF count , SD signal and SK signal),autotuning starts from that frequency. When the first broadcast station is detected, that frequency is held until the autotuning key is pressed thereafter, even when there is no SK signal. When the IF count and SD check are judged to be present, the autotuning operation is the same as normal autotuning, except that the SK signal is detected after 375 to 500 ms. Autotuning(seek up) is performed automatically only when VF band is selected by <input type="text" value="VF"/> key for the first time. Autotuning is not performed automatically even if another tuning key (other than autotuning) is pressed. | | | | | | | | | | | | | | | | | | | | | | | | | | | | | | | | | | | | | | | | | | | | | | | | | | | | | | | | | | | | | | | | | | | | | | | | | | | | | | | | | | | | | | | | | | | | | | | | | | | | | | | | | | | | | | | | | | | | | | | | |
| VF | | | | | | | | | | | | | | | | | | | | | | | | | | | | | | | | | | | | | | | | | | | | | | | | | | | | | | | | | | | | | | | | | | | | | | | | | | | | | | | | | | | | | | | | | | | | | | | | | | | | | | | | | | | | | | | | | | | | | | | | | |

| Symbol | Function |
|--|--|
| <p style="text-align: center; border: 1px solid black; width: 50px; margin: 0 auto;">VF</p> | <p>To reset the VF band, press the VF key or BAND key.</p> <p>The VF band has 6 independent memories. The last channel is also independent.</p> <p>When the device is set to the tape or CD mode by TPSET or CDSET switch while on the VF band, it switches to the DK standby mode. The device also switches to the DK standby mode when the VF key is pressed in the tape or CD mode. In the DK standby mode, all the keys, other than the BAND key, are valid. When the DK switch is set to ON in the DK standby mode, the device switches to the DK ON mode. In the DK ON mode, radio muting (\overline{RDMUTE} pin) is turned off and audio muting (\overline{AMUTE} pin) is turned on.</p> <p>When both the SD and SK signals or one of signals are lost during VF band reception(including TAPE or CD DK standby mode), BEEP is output.</p> <p>The SD and SK signals are checked 512 times once every 30 ms and if there are no SD and SK signals for 256 times or more, BEEP is output.</p> <p>For BEEP, 120 ms ON and 120 ms OFF are output 5 times, respectively.</p> |
| <p style="text-align: center; border: 1px solid black; width: 50px; margin: 0 auto;">PSCAN AMEMO</p> | <p>Preset memory scan and auto store memory key.</p> <p>The auto store memory function is enabled when initialized diode DISAMEMO is 0.</p> <p>When the auto store memory is used (DISAMEMO = 0), when this key is pressed and released within 2 seconds, preset memory scanning is performed. When this key is held down for more than 2 seconds, operation switches to auto store memory operation.</p> <p>When the auto store memory is not used (DISAMEMO = 1), the preset memory scanning operation starts the moment the button is pressed.</p> <p>The preset memory scan and auto store memory operations are described below.</p> <p>(1) Preset memory scan operation</p> <p>The preset memory contents are called automatically every 5 seconds.</p> <p>If other than the current preset memory is being received, the preset memories are called from M1, and if a present memory is being received the preset memories are called from the next preset memory (for instance, from M4 if M3 is being received) sequentially every 5 seconds.</p> <p>This operation is shown below.</p> <p>Example When FM1 band being received.</p> <p style="margin-left: 40px;">FM1</p> <div style="margin-left: 40px; border: 1px solid black; padding: 5px; display: inline-block;"> <p>M1 → M2 → M3 → M4 → M5 → M6</p> </div> <p style="margin-left: 40px;">Other than preset memory being received on FM1 band</p> <p style="margin-left: 100px;">M3 being received on FM1 band</p> <p>This operation is the same for the MW bands (MW1, MW2) and LW band.</p> |

| Symbol | Function | | | | | | |
|--|---|-------------|-------------|---|--|---|--|
| <div style="border: 1px solid black; padding: 2px; width: fit-content; margin-bottom: 10px;">PSCAN AMEMO</div> | <p>When the next preset memory is called at the end of 5 second hold, BEEP is output.</p> <p>During 5 second hold, the preset memory number display flashes at 1 Hz (duty 50%). The "ch" display does not flash.</p> <p>To stop at that preset memory during 5 second hold, press this key again, or press the same preset memory key as the preset memory being received. Writing of preset memory (for example, writing to M5 during M1 hold) is also possible, but the preset memory scan operation ends when the preset memory was written.</p> <p>The preset memory write operation during 5 second hold is described below.</p> <table border="1" style="width: 100%; border-collapse: collapse;"> <thead> <tr> <th data-bbox="349 609 420 649">M2S</th> <th data-bbox="420 609 1377 649">Description</th> </tr> </thead> <tbody> <tr> <td data-bbox="349 649 420 956" style="text-align: center; vertical-align: middle;">0</td> <td data-bbox="420 649 1377 956"> <p>When the ME key is pressed, the device enters the 5 second memory write mode. Writing is performed by pressing a M1 (TP1) to M6 key in the memory writable mode. At the end of writing, auto preset memory scanning stops. In the memory writable mode, the "ch" display flashes. If no operation is performed within 5 seconds, the next preset memory channel is called and auto preset scanning continues.</p> <p>If the ME key is pressed again in the memory writable mode, the memory writable mode is canceled and the next channel is called 5 seconds after the key was pressed.</p> </td> </tr> <tr> <td data-bbox="349 956 420 1181" style="text-align: center; vertical-align: middle;">1</td> <td data-bbox="420 956 1377 1181"> <p>When a M1 (TP1) to M6 key is pressed for more than 2 seconds, the frequency currently being received is written to the preset memory corresponding to the pressed key. Auto preset scanning ends when the frequency was written to the preset memory (2 seconds after the key was pressed).</p> </td> </tr> </tbody> </table> | M2S | Description | 0 | <p>When the ME key is pressed, the device enters the 5 second memory write mode. Writing is performed by pressing a M1 (TP1) to M6 key in the memory writable mode. At the end of writing, auto preset memory scanning stops. In the memory writable mode, the "ch" display flashes. If no operation is performed within 5 seconds, the next preset memory channel is called and auto preset scanning continues.</p> <p>If the ME key is pressed again in the memory writable mode, the memory writable mode is canceled and the next channel is called 5 seconds after the key was pressed.</p> | 1 | <p>When a M1 (TP1) to M6 key is pressed for more than 2 seconds, the frequency currently being received is written to the preset memory corresponding to the pressed key. Auto preset scanning ends when the frequency was written to the preset memory (2 seconds after the key was pressed).</p> |
| | M2S | Description | | | | | |
| 0 | <p>When the ME key is pressed, the device enters the 5 second memory write mode. Writing is performed by pressing a M1 (TP1) to M6 key in the memory writable mode. At the end of writing, auto preset memory scanning stops. In the memory writable mode, the "ch" display flashes. If no operation is performed within 5 seconds, the next preset memory channel is called and auto preset scanning continues.</p> <p>If the ME key is pressed again in the memory writable mode, the memory writable mode is canceled and the next channel is called 5 seconds after the key was pressed.</p> | | | | | | |
| 1 | <p>When a M1 (TP1) to M6 key is pressed for more than 2 seconds, the frequency currently being received is written to the preset memory corresponding to the pressed key. Auto preset scanning ends when the frequency was written to the preset memory (2 seconds after the key was pressed).</p> | | | | | | |
| | <p>When one of the following keys is pressed during preset memory scanning, preset memory scanning stops and the operation of the pressed key is performed.</p> <div style="display: flex; flex-wrap: wrap; justify-content: space-around; margin-bottom: 10px;"> <div style="border: 1px solid black; padding: 2px; margin: 2px;">MAN UP</div> <div style="border: 1px solid black; padding: 2px; margin: 2px;">MAN DWN</div> <div style="border: 1px solid black; padding: 2px; margin: 2px;">SEEK UP</div> <div style="border: 1px solid black; padding: 2px; margin: 2px;">SEEK DWN</div> </div> <div style="display: flex; flex-wrap: wrap; justify-content: space-around; margin-bottom: 10px;"> <div style="border: 1px solid black; padding: 2px; margin: 2px;">SCAN UP</div> <div style="border: 1px solid black; padding: 2px; margin: 2px;">SCAN DWN</div> <div style="border: 1px solid black; padding: 2px; margin: 2px;">VF</div> </div> <p>Memory call key other than memory being received (held) Band switching key</p> <p>When one of the following keys is pressed during preset memory scanning, after the operation of the pressed key is performed, preset memory scanning is continued.</p> <div style="display: flex; flex-wrap: wrap; justify-content: space-around; margin-bottom: 10px;"> <div style="border: 1px solid black; padding: 2px; margin: 2px;">LOUD</div> <div style="border: 1px solid black; padding: 2px; margin: 2px;">LOC (TP4)</div> <div style="border: 1px solid black; padding: 2px; margin: 2px;">MONO (TP5)</div> </div> | | | | | | |

| Symbol | Function | | | | | | | | | | | | | | | | | | | | | | | | | | | | | | | | | | | | | | | | | | | | | | | | | | | | | | | | | | | | | | | | |
|-----------|---|-----------|------|------------|------|--------------------|------------------|------------|------------------|------|------|---------|-----|-------|--|-----|-----|-----|-----|-----|--|-----------|-------------|--|--|------------|--|------------|------------|------------|------------------|--|--|--|--|-------|--|-------|-------|-------|--|-----------|------|------|------|------|------|------|------|---------|--|-------|--|------------|-----|-----|-----|-----------|-------------|--|--|--|--|--------------------|------------------|
| | <p>Example) FM band (FM1, M1 = 89.1MHz, M2 = 91.9MHz, M3 = 93.1MHz, M4 = 95.1MHz) M2S = 0</p> <p>(2) Auto store memory</p> <p>This operation searches for a broadcast station and writes it to preset memory automatically.</p> <p>Broadcast station search is performed in the up direction, starting from the frequency currently being received:</p> <p>If the preset memory channel which is written is receiving the current preset memory, it is incremented from the preset memory channel being received (from M3 if M3 is being received). If a channel other than a preset memory channel is being received, the preset memory channel which is written is incremented from M1. When broadcast stations are stored up to M6, the auto store memory operation ends.</p> <p>The auto store memory operation broadcast station search method in the LOCAL mode and DX mode differs as shown below.</p> <ul style="list-style-type: none"> - DX mode <p>The frequencies are searched in the up direction, starting from the frequency currently being received, and ends when the preset memories are written up to M6 or all the search frequencies were searched once.</p> <p>Example 1) USA1, FM band 89.5MHz (M3) reception</p> <table border="1" style="width: 100%; border-collapse: collapse;"> <tr> <td>Frequency</td> <td>89.5</td> <td>89.6</td> <td>Seek</td> <td>91.5</td> <td>91.9</td> <td>94.0</td> <td>96.2</td> <td>99.5</td> <td>91.5</td> </tr> <tr> <td>Display</td> <td>ch3</td> <td>↑ ch3</td> <td></td> <td>ch3</td> <td>ch4</td> <td>ch4</td> <td>ch5</td> <td>ch6</td> <td></td> </tr> <tr> <td>Operation</td> <td colspan="2" style="text-align: center;">PSCAN AMEMO</td> <td></td> <td>Station M3</td> <td></td> <td>Station M4</td> <td>Station M5</td> <td>Station M6</td> <td>Auto Memory Stop</td> </tr> <tr> <td></td> <td></td> <td></td> <td></td> <td>Write</td> <td></td> <td>Write</td> <td>Write</td> <td>Write</td> <td></td> </tr> </table> <p>Example 2) Japan, FM band 78.0 MHz reception</p> <table border="1" style="width: 100%; border-collapse: collapse;"> <tr> <td>Frequency</td> <td>78.0</td> <td>78.1</td> <td>Seek</td> <td>90.0</td> <td>76.0</td> <td>77.9</td> <td>78.0</td> </tr> <tr> <td>Display</td> <td></td> <td>↑ ch1</td> <td></td> <td>No Station</td> <td>ch1</td> <td>ch1</td> <td>ch1</td> </tr> <tr> <td>Operation</td> <td colspan="2" style="text-align: center;">PSCAN AMEMO</td> <td></td> <td></td> <td></td> <td>1 Cycle No Station</td> <td>Auto Memory Stop</td> </tr> </table> <p>For auto store memory in the DX mode, the SD pin broadcast station detection level is :</p> | Frequency | 89.5 | 89.6 | Seek | 91.5 | 91.9 | 94.0 | 96.2 | 99.5 | 91.5 | Display | ch3 | ↑ ch3 | | ch3 | ch4 | ch4 | ch5 | ch6 | | Operation | PSCAN AMEMO | | | Station M3 | | Station M4 | Station M5 | Station M6 | Auto Memory Stop | | | | | Write | | Write | Write | Write | | Frequency | 78.0 | 78.1 | Seek | 90.0 | 76.0 | 77.9 | 78.0 | Display | | ↑ ch1 | | No Station | ch1 | ch1 | ch1 | Operation | PSCAN AMEMO | | | | | 1 Cycle No Station | Auto Memory Stop |
| Frequency | 89.5 | 89.6 | Seek | 91.5 | 91.9 | 94.0 | 96.2 | 99.5 | 91.5 | | | | | | | | | | | | | | | | | | | | | | | | | | | | | | | | | | | | | | | | | | | | | | | | | | | | | | | | |
| Display | ch3 | ↑ ch3 | | ch3 | ch4 | ch4 | ch5 | ch6 | | | | | | | | | | | | | | | | | | | | | | | | | | | | | | | | | | | | | | | | | | | | | | | | | | | | | | | | | |
| Operation | PSCAN AMEMO | | | Station M3 | | Station M4 | Station M5 | Station M6 | Auto Memory Stop | | | | | | | | | | | | | | | | | | | | | | | | | | | | | | | | | | | | | | | | | | | | | | | | | | | | | | | | |
| | | | | Write | | Write | Write | Write | | | | | | | | | | | | | | | | | | | | | | | | | | | | | | | | | | | | | | | | | | | | | | | | | | | | | | | | | |
| Frequency | 78.0 | 78.1 | Seek | 90.0 | 76.0 | 77.9 | 78.0 | | | | | | | | | | | | | | | | | | | | | | | | | | | | | | | | | | | | | | | | | | | | | | | | | | | | | | | | | | |
| Display | | ↑ ch1 | | No Station | ch1 | ch1 | ch1 | | | | | | | | | | | | | | | | | | | | | | | | | | | | | | | | | | | | | | | | | | | | | | | | | | | | | | | | | | |
| Operation | PSCAN AMEMO | | | | | 1 Cycle No Station | Auto Memory Stop | | | | | | | | | | | | | | | | | | | | | | | | | | | | | | | | | | | | | | | | | | | | | | | | | | | | | | | | | | |

PSCAN AMEMO

| Symbol | Function | | | | | | | | | | | | | | | | | | | | | | | | | | | | | | | | | | | | | | | | | | | | | | | | | | | | | | | | | | | | | | | | | | | | | | | | | | | | | | | | | | | | | | | |
|-----------|---|---|---|------|-------|---------------------------------|--------------------------|-----|------|---------|-------|--|-------|--|-------|-------|-------|-----------|--|--|------------------------|--|--|--|--|-----------|------|------|-----|------|---------|-----|-----|-----|-----|-----------|--|--|--|--|-----------|------|------|-----|-----|------|---------|-----|-----|-----|-----|-----|-----------|------------------------|--|--|--|--|-----------|------|---------|---|-----------|--|------|------|---|--|----------|-------------------|---------------------------------|-------------------------|-------------------|---------------------------------|-------------------------|----------------|---------------------------------|-------------------------|----------|-------------------|---------------------------------|-------------------------|-------------------|---------------------------------|-------------------------|----------------|---------------------------------|-------------------------|
| | <table border="1" style="margin: auto; border-collapse: collapse;"> <thead> <tr> <th style="width: 10%;">Band</th> <th colspan="2">Lowest Voltage to Determine the Presence of Station</th> </tr> </thead> <tbody> <tr> <td>FM</td> <td rowspan="4" style="text-align: center; vertical-align: middle;">$\frac{12.5}{64} \times V_{DD}$</td> <td rowspan="4" style="text-align: center; vertical-align: middle;">0.977 V at $V_{DD} = 5V$</td> </tr> <tr> <td>MW</td> </tr> <tr> <td>LW</td> </tr> <tr> <td>VF</td> </tr> </tbody> </table> | Band | Lowest Voltage to Determine the Presence of Station | | FM | $\frac{12.5}{64} \times V_{DD}$ | 0.977 V at $V_{DD} = 5V$ | MW | LW | VF | | | | | | | | | | | | | | | | | | | | | | | | | | | | | | | | | | | | | | | | | | | | | | | | | | | | | | | | | | | | | | | | | | | | | | | | | | | | | | |
| Band | Lowest Voltage to Determine the Presence of Station | | | | | | | | | | | | | | | | | | | | | | | | | | | | | | | | | | | | | | | | | | | | | | | | | | | | | | | | | | | | | | | | | | | | | | | | | | | | | | | | | | | | | | | |
| FM | $\frac{12.5}{64} \times V_{DD}$ | 0.977 V at $V_{DD} = 5V$ | | | | | | | | | | | | | | | | | | | | | | | | | | | | | | | | | | | | | | | | | | | | | | | | | | | | | | | | | | | | | | | | | | | | | | | | | | | | | | | | | | | | | | |
| MW | | | | | | | | | | | | | | | | | | | | | | | | | | | | | | | | | | | | | | | | | | | | | | | | | | | | | | | | | | | | | | | | | | | | | | | | | | | | | | | | | | | | | | | | |
| LW | | | | | | | | | | | | | | | | | | | | | | | | | | | | | | | | | | | | | | | | | | | | | | | | | | | | | | | | | | | | | | | | | | | | | | | | | | | | | | | | | | | | | | | | |
| VF | | | | | | | | | | | | | | | | | | | | | | | | | | | | | | | | | | | | | | | | | | | | | | | | | | | | | | | | | | | | | | | | | | | | | | | | | | | | | | | | | | | | | | | | |
| | <p>- LOCAL mode</p> <p>The frequencies are searched in the up direction, starting from the frequency currently being received. In the LOCAL mode, the SD detection level is changed and the frequencies are searched twice. In the DX mode, the frequencies are searched once. When the preset memories are written up to M6 during this time or at the end of 3 searches, the auto store memory operation ends.</p> <p>Example) Europe, AM band 1422 kHz reception</p> <div style="text-align: center;"> <table style="margin: auto; border-collapse: collapse;"> <tr> <td style="padding: 5px;">Frequency</td> <td style="padding: 5px;">1422</td> <td style="padding: 5px;">1531</td> <td style="padding: 5px;">Seek</td> <td style="padding: 5px;">1611</td> <td style="padding: 5px;">1620</td> <td style="padding: 5px;">522</td> <td style="padding: 5px;">1413</td> </tr> <tr> <td style="padding: 5px;">Display</td> <td colspan="2" style="text-align: center;">↑ ch1</td> <td colspan="2" style="text-align: center;">→ ch1</td> <td style="text-align: center;">→ ch2</td> <td style="text-align: center;">→ ch2</td> <td style="text-align: center;">→ ch2</td> </tr> <tr> <td style="padding: 5px;">Operation</td> <td colspan="2" style="text-align: center;"> <div style="border: 1px solid black; padding: 2px; display: inline-block;">PSCAN AMEMO</div> </td> <td colspan="5" style="text-align: center;"> Station M1 Write </td> </tr> </table> <p style="text-align: center;">(LOCAL, 1st Time)</p> <table style="margin: auto; border-collapse: collapse;"> <tr> <td style="padding: 5px;">Frequency</td> <td style="padding: 5px;">1422</td> <td style="padding: 5px;">1620</td> <td style="padding: 5px;">522</td> <td style="padding: 5px;">1413</td> </tr> <tr> <td style="padding: 5px;">Display</td> <td style="text-align: center;">ch2</td> <td style="text-align: center;">ch2</td> <td style="text-align: center;">ch2</td> <td style="text-align: center;">ch2</td> </tr> <tr> <td style="padding: 5px;">Operation</td> <td colspan="4" style="text-align: center;"> <div style="border: 1px solid black; padding: 2px; display: inline-block;">PSCAN AMEMO</div> </td> </tr> </table> <p style="text-align: center;">(LOCAL, 2nd Time)</p> <table style="margin: auto; border-collapse: collapse;"> <tr> <td style="padding: 5px;">Frequency</td> <td style="padding: 5px;">1422</td> <td style="padding: 5px;">1620</td> <td style="padding: 5px;">522</td> <td style="padding: 5px;">695</td> <td style="padding: 5px;">1413</td> </tr> <tr> <td style="padding: 5px;">Display</td> <td style="text-align: center;">ch2</td> <td style="text-align: center;">ch2</td> <td style="text-align: center;">ch2</td> <td style="text-align: center;">ch2</td> <td style="text-align: center;">ch3</td> </tr> <tr> <td style="padding: 5px;">Operation</td> <td colspan="5" style="text-align: center;"> Station M2 Write </td> </tr> </table> <p style="text-align: center;">(DX 1st Time)</p> <table style="margin: auto; border-collapse: collapse;"> <tr> <td style="padding: 5px;">Frequency</td> <td style="padding: 5px;">1422</td> </tr> <tr> <td style="padding: 5px;">Display</td> <td style="text-align: center;">←</td> </tr> <tr> <td style="padding: 5px;">Operation</td> <td style="text-align: center;"> <div style="border: 1px solid black; padding: 2px; display: inline-block;">PSCAN AMEMO</div> </td> </tr> </table> <p style="text-align: center;">Auto Memory Stop</p> <p>The SD detection level for LOCAL mode auto store memory is :</p> <table border="1" style="margin: auto; border-collapse: collapse; width: 100%;"> <thead> <tr> <th style="width: 10%;">Band</th> <th style="width: 10%;">Mode</th> <th colspan="2">Lowest Voltage judged a Broadcast Station</th> </tr> </thead> <tbody> <tr> <td rowspan="3" style="text-align: center;">FM VF</td> <td style="text-align: center;">LOCAL 1st time</td> <td style="text-align: center;">$\frac{44.5}{64} \times V_{DD}$</td> <td style="text-align: center;">3.447V at $V_{DD} = 5V$</td> </tr> <tr> <td style="text-align: center;">LOCAL 2nd time</td> <td style="text-align: center;">$\frac{28.5}{64} \times V_{DD}$</td> <td style="text-align: center;">2.227V at $V_{DD} = 5V$</td> </tr> <tr> <td style="text-align: center;">DX 1st time</td> <td style="text-align: center;">$\frac{12.5}{64} \times V_{DD}$</td> <td style="text-align: center;">0.977V at $V_{DD} = 5V$</td> </tr> <tr> <td rowspan="3" style="text-align: center;">MW LW</td> <td style="text-align: center;">LOCAL 1st time</td> <td style="text-align: center;">$\frac{18.5}{64} \times V_{DD}$</td> <td style="text-align: center;">1.445V at $V_{DD} = 5V$</td> </tr> <tr> <td style="text-align: center;">LOCAL 2nd time</td> <td style="text-align: center;">$\frac{15.5}{64} \times V_{DD}$</td> <td style="text-align: center;">1.211V at $V_{DD} = 5V$</td> </tr> <tr> <td style="text-align: center;">DX 1st time</td> <td style="text-align: center;">$\frac{12.5}{64} \times V_{DD}$</td> <td style="text-align: center;">0.997V at $V_{DD} = 5V$</td> </tr> </tbody> </table> </div> | Frequency | 1422 | 1531 | Seek | 1611 | 1620 | 522 | 1413 | Display | ↑ ch1 | | → ch1 | | → ch2 | → ch2 | → ch2 | Operation | <div style="border: 1px solid black; padding: 2px; display: inline-block;">PSCAN AMEMO</div> | | Station M1 Write | | | | | Frequency | 1422 | 1620 | 522 | 1413 | Display | ch2 | ch2 | ch2 | ch2 | Operation | <div style="border: 1px solid black; padding: 2px; display: inline-block;">PSCAN AMEMO</div> | | | | Frequency | 1422 | 1620 | 522 | 695 | 1413 | Display | ch2 | ch2 | ch2 | ch2 | ch3 | Operation | Station M2 Write | | | | | Frequency | 1422 | Display | ← | Operation | <div style="border: 1px solid black; padding: 2px; display: inline-block;">PSCAN AMEMO</div> | Band | Mode | Lowest Voltage judged a Broadcast Station | | FM VF | LOCAL 1st time | $\frac{44.5}{64} \times V_{DD}$ | 3.447V at $V_{DD} = 5V$ | LOCAL 2nd time | $\frac{28.5}{64} \times V_{DD}$ | 2.227V at $V_{DD} = 5V$ | DX 1st time | $\frac{12.5}{64} \times V_{DD}$ | 0.977V at $V_{DD} = 5V$ | MW LW | LOCAL 1st time | $\frac{18.5}{64} \times V_{DD}$ | 1.445V at $V_{DD} = 5V$ | LOCAL 2nd time | $\frac{15.5}{64} \times V_{DD}$ | 1.211V at $V_{DD} = 5V$ | DX 1st time | $\frac{12.5}{64} \times V_{DD}$ | 0.997V at $V_{DD} = 5V$ |
| Frequency | 1422 | 1531 | Seek | 1611 | 1620 | 522 | 1413 | | | | | | | | | | | | | | | | | | | | | | | | | | | | | | | | | | | | | | | | | | | | | | | | | | | | | | | | | | | | | | | | | | | | | | | | | | | | | | | | | |
| Display | ↑ ch1 | | → ch1 | | → ch2 | → ch2 | → ch2 | | | | | | | | | | | | | | | | | | | | | | | | | | | | | | | | | | | | | | | | | | | | | | | | | | | | | | | | | | | | | | | | | | | | | | | | | | | | | | | | | |
| Operation | <div style="border: 1px solid black; padding: 2px; display: inline-block;">PSCAN AMEMO</div> | | Station M1 Write | | | | | | | | | | | | | | | | | | | | | | | | | | | | | | | | | | | | | | | | | | | | | | | | | | | | | | | | | | | | | | | | | | | | | | | | | | | | | | | | | | | | | |
| Frequency | 1422 | 1620 | 522 | 1413 | | | | | | | | | | | | | | | | | | | | | | | | | | | | | | | | | | | | | | | | | | | | | | | | | | | | | | | | | | | | | | | | | | | | | | | | | | | | | | | | | | | | |
| Display | ch2 | ch2 | ch2 | ch2 | | | | | | | | | | | | | | | | | | | | | | | | | | | | | | | | | | | | | | | | | | | | | | | | | | | | | | | | | | | | | | | | | | | | | | | | | | | | | | | | | | | | |
| Operation | <div style="border: 1px solid black; padding: 2px; display: inline-block;">PSCAN AMEMO</div> | | | | | | | | | | | | | | | | | | | | | | | | | | | | | | | | | | | | | | | | | | | | | | | | | | | | | | | | | | | | | | | | | | | | | | | | | | | | | | | | | | | | | | | |
| Frequency | 1422 | 1620 | 522 | 695 | 1413 | | | | | | | | | | | | | | | | | | | | | | | | | | | | | | | | | | | | | | | | | | | | | | | | | | | | | | | | | | | | | | | | | | | | | | | | | | | | | | | | | | | |
| Display | ch2 | ch2 | ch2 | ch2 | ch3 | | | | | | | | | | | | | | | | | | | | | | | | | | | | | | | | | | | | | | | | | | | | | | | | | | | | | | | | | | | | | | | | | | | | | | | | | | | | | | | | | | | |
| Operation | Station M2 Write | | | | | | | | | | | | | | | | | | | | | | | | | | | | | | | | | | | | | | | | | | | | | | | | | | | | | | | | | | | | | | | | | | | | | | | | | | | | | | | | | | | | | | | |
| Frequency | 1422 | | | | | | | | | | | | | | | | | | | | | | | | | | | | | | | | | | | | | | | | | | | | | | | | | | | | | | | | | | | | | | | | | | | | | | | | | | | | | | | | | | | | | | | |
| Display | ← | | | | | | | | | | | | | | | | | | | | | | | | | | | | | | | | | | | | | | | | | | | | | | | | | | | | | | | | | | | | | | | | | | | | | | | | | | | | | | | | | | | | | | | |
| Operation | <div style="border: 1px solid black; padding: 2px; display: inline-block;">PSCAN AMEMO</div> | | | | | | | | | | | | | | | | | | | | | | | | | | | | | | | | | | | | | | | | | | | | | | | | | | | | | | | | | | | | | | | | | | | | | | | | | | | | | | | | | | | | | | | |
| Band | Mode | Lowest Voltage judged a Broadcast Station | | | | | | | | | | | | | | | | | | | | | | | | | | | | | | | | | | | | | | | | | | | | | | | | | | | | | | | | | | | | | | | | | | | | | | | | | | | | | | | | | | | | | | |
| FM VF | LOCAL 1st time | $\frac{44.5}{64} \times V_{DD}$ | 3.447V at $V_{DD} = 5V$ | | | | | | | | | | | | | | | | | | | | | | | | | | | | | | | | | | | | | | | | | | | | | | | | | | | | | | | | | | | | | | | | | | | | | | | | | | | | | | | | | | | | | |
| | LOCAL 2nd time | $\frac{28.5}{64} \times V_{DD}$ | 2.227V at $V_{DD} = 5V$ | | | | | | | | | | | | | | | | | | | | | | | | | | | | | | | | | | | | | | | | | | | | | | | | | | | | | | | | | | | | | | | | | | | | | | | | | | | | | | | | | | | | | |
| | DX 1st time | $\frac{12.5}{64} \times V_{DD}$ | 0.977V at $V_{DD} = 5V$ | | | | | | | | | | | | | | | | | | | | | | | | | | | | | | | | | | | | | | | | | | | | | | | | | | | | | | | | | | | | | | | | | | | | | | | | | | | | | | | | | | | | | |
| MW LW | LOCAL 1st time | $\frac{18.5}{64} \times V_{DD}$ | 1.445V at $V_{DD} = 5V$ | | | | | | | | | | | | | | | | | | | | | | | | | | | | | | | | | | | | | | | | | | | | | | | | | | | | | | | | | | | | | | | | | | | | | | | | | | | | | | | | | | | | | |
| | LOCAL 2nd time | $\frac{15.5}{64} \times V_{DD}$ | 1.211V at $V_{DD} = 5V$ | | | | | | | | | | | | | | | | | | | | | | | | | | | | | | | | | | | | | | | | | | | | | | | | | | | | | | | | | | | | | | | | | | | | | | | | | | | | | | | | | | | | | |
| | DX 1st time | $\frac{12.5}{64} \times V_{DD}$ | 0.997V at $V_{DD} = 5V$ | | | | | | | | | | | | | | | | | | | | | | | | | | | | | | | | | | | | | | | | | | | | | | | | | | | | | | | | | | | | | | | | | | | | | | | | | | | | | | | | | | | | | |

| Symbol | Function | | | | |
|--|--|---------|-----------|--|--|
| <div style="border: 1px solid black; padding: 2px; width: fit-content; margin-bottom: 5px;">PSCAN AMEMO</div> | <p>When the auto local function is used, each time the <div style="border: 1px solid black; padding: 2px; display: inline-block;">PSCAN AMEMO</div> key is pressed, the local mode is switched as shown below.</p> <p>LOCAL1 → LOCAL2 → DX → auto memory stop</p> <p>When the local mode is switched, the auto memory operation is repeated from the frequency at which is started. When the auto memory operation was stopped, if even one broadcast station was written, operation shifts automatically from the preset memory when the auto memory operation started to preset scan operation.</p> | | | | |
| <div style="border: 1px solid black; padding: 2px; width: fit-content; margin-bottom: 5px;">SEEK UP</div> <div style="border: 1px solid black; padding: 2px; width: fit-content;">SEEK DWN</div> | <p>Autotuning (seek operation) key.</p> <p>The frequencies are incremented (<div style="border: 1px solid black; padding: 2px; display: inline-block;">SEEK UP</div> key) or decremented (<div style="border: 1px solid black; padding: 2px; display: inline-block;">SEEK DWN</div> key) in 1 channel space and whether or not there is a broadcast station (IF count and SD signal) is detected at each receiving frequency and when there is a broadcast station, that frequency is held.</p> <p>On the VF band, when there is judged to be a broadcast station by IF count and SD signal the SK switch is checked 250 to 375 ms later and if there is an SK signal, that frequency is held.</p> <p>When seek up (seek down) reaches the highest (lowest) frequency, it returns to the lowest (highest) frequency and, that is, sawtooth wave mode tuning is performed.</p> <p>The channel seek up (seek down) operation is shown below:</p> <table border="1" style="width: 100%; border-collapse: collapse;"> <thead> <tr> <th style="width: 50%; text-align: center;">Seek Up</th> <th style="width: 50%; text-align: center;">Seek Down</th> </tr> </thead> <tbody> <tr> <td style="text-align: center;"> </td> <td style="text-align: center;"> </td> </tr> </tbody> </table> <p>For the S (slow) and F (fast) IF count conditions, see the FMIF pin and AMIF pin above.</p> <p>For the 1 channel space frequency width, see the receiving frequencies above.</p> | Seek Up | Seek Down | | |
| Seek Up | Seek Down | | | | |
| | | | | | |

| Symbol | Function |
|-------------------------------|---|
| AUTOSTP | Description |
| 1 | <p>Even if the presence of a station is determined, tuning does not stop at its frequency when the keys are held down.</p> <p>Example:FM band</p> <p>RDMUTE pin</p> <p>When the band selection is switched, then returned to the original band and when the radio is turned off(including a mode transition), then on, auto-tuning locks in the frequency with when the seek started.</p> <p>All keys other than those shown in the table above are invalid(except for POWER key). The AUTO 500 switch(diode matrix) must be set to '0' when SEEK UP and SEEK DWN keys are used.</p> |
| SEEK UP | Operation |
| SEEK DWN | <ul style="list-style-type: none"> - SEEK UP key during seek-up and SEEK DWN key during seek-down The seek stops and auto-tuning returns to the frequency with which the seek started. - SEEK DWN key during seek-up and SEEK UP key during seek-down The operation of the key pressed(seek-down if pressed during seek-up) is initiated, starting with the frequency tuned in when the key is pressed. The between-key operation is also enabled. |
| SCAN UP SCAN DWN | Scan-up(Scan-down) with the frequency tuned in when the key is pressed. |
| MAN UP MAN DWN | The seek stops and auto-tuning returns to the frequency with which the seek started. |
| BAND | <p>The seek stops and the new band is selected in the following sequence.</p> <p style="text-align: center;">FM1 → FM2 → FM3 → MW1 → MW2 → LW</p> <p>The bands inhibited in the particular reception area and by DISFM3, ENMW2, DISLW switches are skipped. Tuning returns to the frequency with which the seek started when the original band is selected.</p> |
| M1(TP1) to M6 | Regardless of the setting of the M2S switch, the contents are called for the preset memory associated with any key pressed. |
| VF | The seek stops and the key operation starts. |
| PSCAN AMEMO | The seek stops and the preset-scan starts. |
| LOUD LOD(TP4) MONO(TP5) | The operations of the keys pressed are initiated. The seek continues. |

| Symbol | Function | | | | | | | | | |
|--|--|-----------|--|--|--|--|--|---|--|---|
| <div style="border: 1px solid black; padding: 2px; width: fit-content; margin-bottom: 5px;">SCAN UP</div> <div style="border: 1px solid black; padding: 2px; width: fit-content;">SCAN DWN</div> | <p>Auto tuning (scan operation) key.</p> <p>The frequencies are searched up (SCAN UP key) or down (SCAN DWN key) in 1 channel steps and whether or not there is a broadcast station (IF count and SD signal) is detected at each receiving frequency and when a broadcast station is judged to be present, that frequency is held for 5 seconds.</p> <p>On the VF band, whether or not there is an SK signal is detected as well as seek operation. If no operation is performed during this 5 seconds, the seek operation is repeated and the next broadcast station is received sequentially every 5 seconds (scan operation).</p> <p>During this 5 seconds hold, the frequency display flashes at 1 Hz (duty 50%).</p> <p>At the end of the 5 seconds hold, BEEP is output.</p> <p>Seek operations (channel up/down method, AUTOSTP switch and IF count, SD detection, SK signal detection) are the same as the SEEK UP and SEEK DWN keys. When the radio is turned off (including mode switching) and then turned on, the frequency held last (when there is not even 1 broadcast station, the frequency when the scan operation started) is received.</p> <p>The operation of each key during seek operation (other than at 5 seconds hold) is shown below.</p> | | | | | | | | | |
| <table border="1" style="width: 100%; border-collapse: collapse;"> <thead> <tr> <th style="width: 30%;">Key</th> <th>Operation</th> </tr> </thead> <tbody> <tr> <td style="text-align: center;"> <div style="border: 1px solid black; padding: 2px; width: fit-content; margin-bottom: 5px;">SCAN UP</div> <div style="border: 1px solid black; padding: 2px; width: fit-content;">SCAN DWN</div> </td> <td> <ul style="list-style-type: none"> - SCAN UP key during scan up and SCAN DWN key during scan down <p>Scanning stops and returns to the frequency held last.</p> <p>However, when the auto local function is used, the local mode is switched.</p> <ul style="list-style-type: none"> - SCAN DWN key during scan up and SCAN UP key during scan down <p>Operation shifts to operation of the pressed key from the frequency when the key was pressed.</p> </td> </tr> <tr> <td style="text-align: center;"> <div style="border: 1px solid black; padding: 2px; width: fit-content; margin-bottom: 5px;">SEEK UP</div> <div style="border: 1px solid black; padding: 2px; width: fit-content;">SEEK DWN</div> </td> <td> <p>Scanning stops and seek operation starts from the frequency when the key was pressed.</p> </td> </tr> <tr> <td style="text-align: center;"> <div style="border: 1px solid black; padding: 2px; width: fit-content; margin-bottom: 5px;">MAN UP</div> <div style="border: 1px solid black; padding: 2px; width: fit-content;">MAN DWN</div> </td> <td> <p>Scanning stops and returns to the frequency held last (when a frequency was not held, returns to the frequency when scanning started).</p> <p>Scanning stops whenever any of these keys is pressed even though the AUTO500 switch is 1 (when the MAN UP or MAN DWN key is pressed for more than 0.5 seconds, seek is performed).</p> </td> </tr> <tr> <td style="text-align: center;"> <div style="border: 1px solid black; padding: 2px; width: fit-content;">BAND</div> </td> <td> <p>Scanning stops and the band is switched sequentially as shown below.</p> <div style="text-align: center; border: 1px solid black; padding: 5px; width: fit-content; margin: 10px auto;"> → FM1 → FM2 → FM3 → MW1 → MW2 → LW → </div> <p>However, bands disabled by receiving area and DISFM3, ENMW2 and DISLW switches are skipped.</p> <p>When switching returns to the same band, the frequency held last is received.</p> <p>When a frequency was not held, the frequency when scanning started is received.</p> </td> </tr> </tbody> </table> | Key | Operation | <div style="border: 1px solid black; padding: 2px; width: fit-content; margin-bottom: 5px;">SCAN UP</div> <div style="border: 1px solid black; padding: 2px; width: fit-content;">SCAN DWN</div> | <ul style="list-style-type: none"> - SCAN UP key during scan up and SCAN DWN key during scan down <p>Scanning stops and returns to the frequency held last.</p> <p>However, when the auto local function is used, the local mode is switched.</p> <ul style="list-style-type: none"> - SCAN DWN key during scan up and SCAN UP key during scan down <p>Operation shifts to operation of the pressed key from the frequency when the key was pressed.</p> | <div style="border: 1px solid black; padding: 2px; width: fit-content; margin-bottom: 5px;">SEEK UP</div> <div style="border: 1px solid black; padding: 2px; width: fit-content;">SEEK DWN</div> | <p>Scanning stops and seek operation starts from the frequency when the key was pressed.</p> | <div style="border: 1px solid black; padding: 2px; width: fit-content; margin-bottom: 5px;">MAN UP</div> <div style="border: 1px solid black; padding: 2px; width: fit-content;">MAN DWN</div> | <p>Scanning stops and returns to the frequency held last (when a frequency was not held, returns to the frequency when scanning started).</p> <p>Scanning stops whenever any of these keys is pressed even though the AUTO500 switch is 1 (when the MAN UP or MAN DWN key is pressed for more than 0.5 seconds, seek is performed).</p> | <div style="border: 1px solid black; padding: 2px; width: fit-content;">BAND</div> | <p>Scanning stops and the band is switched sequentially as shown below.</p> <div style="text-align: center; border: 1px solid black; padding: 5px; width: fit-content; margin: 10px auto;"> → FM1 → FM2 → FM3 → MW1 → MW2 → LW → </div> <p>However, bands disabled by receiving area and DISFM3, ENMW2 and DISLW switches are skipped.</p> <p>When switching returns to the same band, the frequency held last is received.</p> <p>When a frequency was not held, the frequency when scanning started is received.</p> |
| Key | Operation | | | | | | | | | |
| <div style="border: 1px solid black; padding: 2px; width: fit-content; margin-bottom: 5px;">SCAN UP</div> <div style="border: 1px solid black; padding: 2px; width: fit-content;">SCAN DWN</div> | <ul style="list-style-type: none"> - SCAN UP key during scan up and SCAN DWN key during scan down <p>Scanning stops and returns to the frequency held last.</p> <p>However, when the auto local function is used, the local mode is switched.</p> <ul style="list-style-type: none"> - SCAN DWN key during scan up and SCAN UP key during scan down <p>Operation shifts to operation of the pressed key from the frequency when the key was pressed.</p> | | | | | | | | | |
| <div style="border: 1px solid black; padding: 2px; width: fit-content; margin-bottom: 5px;">SEEK UP</div> <div style="border: 1px solid black; padding: 2px; width: fit-content;">SEEK DWN</div> | <p>Scanning stops and seek operation starts from the frequency when the key was pressed.</p> | | | | | | | | | |
| <div style="border: 1px solid black; padding: 2px; width: fit-content; margin-bottom: 5px;">MAN UP</div> <div style="border: 1px solid black; padding: 2px; width: fit-content;">MAN DWN</div> | <p>Scanning stops and returns to the frequency held last (when a frequency was not held, returns to the frequency when scanning started).</p> <p>Scanning stops whenever any of these keys is pressed even though the AUTO500 switch is 1 (when the MAN UP or MAN DWN key is pressed for more than 0.5 seconds, seek is performed).</p> | | | | | | | | | |
| <div style="border: 1px solid black; padding: 2px; width: fit-content;">BAND</div> | <p>Scanning stops and the band is switched sequentially as shown below.</p> <div style="text-align: center; border: 1px solid black; padding: 5px; width: fit-content; margin: 10px auto;"> → FM1 → FM2 → FM3 → MW1 → MW2 → LW → </div> <p>However, bands disabled by receiving area and DISFM3, ENMW2 and DISLW switches are skipped.</p> <p>When switching returns to the same band, the frequency held last is received.</p> <p>When a frequency was not held, the frequency when scanning started is received.</p> | | | | | | | | | |

| Symbol | Function | | | | | | | | | | |
|--|---|-----|-----------|--|--|---|---|---|---|--|--|
| | <table border="1" style="width: 100%;"> <thead> <tr> <th style="text-align: center;">Key</th> <th style="text-align: center;">Operation</th> </tr> </thead> <tbody> <tr> <td style="text-align: center;"> <div style="border: 1px solid black; padding: 2px; display: inline-block;">M1 (TP1)</div> to <div style="border: 1px solid black; padding: 2px; display: inline-block;">M6</div> </td> <td>When a key is pressed, scanning stops and the preset memory contents of the pressed key are called without regard to the state of the M2S switch.</td> </tr> <tr> <td style="text-align: center;"> <div style="border: 1px solid black; padding: 2px; display: inline-block;">VF</div> </td> <td>Scanning stops and operation of the key is performed.</td> </tr> <tr> <td style="text-align: center;"> <div style="border: 1px solid black; padding: 2px; display: inline-block;">PSCAN AMEMO</div> </td> <td>Scanning stops and preset scan is performed from M1.</td> </tr> <tr> <td style="text-align: center;"> <div style="border: 1px solid black; padding: 2px; display: inline-block;">LOUD</div> <div style="border: 1px solid black; padding: 2px; display: inline-block;">LOC (TP4)</div> <div style="border: 1px solid black; padding: 2px; display: inline-block;">MONO (TP5)</div> </td> <td>The operation of the pressed key is performed. Seek (scan operation) continues.</td> </tr> </tbody> </table> | Key | Operation | <div style="border: 1px solid black; padding: 2px; display: inline-block;">M1 (TP1)</div> to <div style="border: 1px solid black; padding: 2px; display: inline-block;">M6</div> | When a key is pressed, scanning stops and the preset memory contents of the pressed key are called without regard to the state of the M2S switch. | <div style="border: 1px solid black; padding: 2px; display: inline-block;">VF</div> | Scanning stops and operation of the key is performed. | <div style="border: 1px solid black; padding: 2px; display: inline-block;">PSCAN AMEMO</div> | Scanning stops and preset scan is performed from M1. | <div style="border: 1px solid black; padding: 2px; display: inline-block;">LOUD</div> <div style="border: 1px solid black; padding: 2px; display: inline-block;">LOC (TP4)</div> <div style="border: 1px solid black; padding: 2px; display: inline-block;">MONO (TP5)</div> | The operation of the pressed key is performed. Seek (scan operation) continues. |
| Key | Operation | | | | | | | | | | |
| <div style="border: 1px solid black; padding: 2px; display: inline-block;">M1 (TP1)</div> to <div style="border: 1px solid black; padding: 2px; display: inline-block;">M6</div> | When a key is pressed, scanning stops and the preset memory contents of the pressed key are called without regard to the state of the M2S switch. | | | | | | | | | | |
| <div style="border: 1px solid black; padding: 2px; display: inline-block;">VF</div> | Scanning stops and operation of the key is performed. | | | | | | | | | | |
| <div style="border: 1px solid black; padding: 2px; display: inline-block;">PSCAN AMEMO</div> | Scanning stops and preset scan is performed from M1. | | | | | | | | | | |
| <div style="border: 1px solid black; padding: 2px; display: inline-block;">LOUD</div> <div style="border: 1px solid black; padding: 2px; display: inline-block;">LOC (TP4)</div> <div style="border: 1px solid black; padding: 2px; display: inline-block;">MONO (TP5)</div> | The operation of the pressed key is performed. Seek (scan operation) continues. | | | | | | | | | | |
| <div style="border: 1px solid black; padding: 2px; display: inline-block;">SCAN UP</div> <div style="border: 1px solid black; padding: 2px; display: inline-block;">SCAN DWN</div> | <p>Momentary keys other than those described above are invalid. (However, the <div style="border: 1px solid black; padding: 2px; display: inline-block;">POWER</div> key is valid.)</p> <p>Operation of each key during 5 second hold is shown below.</p> <table border="1" style="width: 100%;"> <thead> <tr> <th style="text-align: center;">Key</th> <th style="text-align: center;">Operation</th> </tr> </thead> <tbody> <tr> <td style="text-align: center;"> <div style="border: 1px solid black; padding: 2px; display: inline-block;">SCAN UP</div> <div style="border: 1px solid black; padding: 2px; display: inline-block;">SCAN DWN</div> </td> <td> <ul style="list-style-type: none"> - <div style="border: 1px solid black; padding: 2px; display: inline-block;">SCAN UP</div> key during scan up and <div style="border: 1px solid black; padding: 2px; display: inline-block;">SCAN DWN</div> Key during scan down Scanning stops and the frequency being held is locked in. - <div style="border: 1px solid black; padding: 2px; display: inline-block;">SCAN DWN</div> key during scan up and <div style="border: 1px solid black; padding: 2px; display: inline-block;">SCAN UP</div> key during scan down And then the operation of the pressed key is performed. </td> </tr> <tr> <td style="text-align: center;"> <div style="border: 1px solid black; padding: 2px; display: inline-block;">SEEK UP</div> <div style="border: 1px solid black; padding: 2px; display: inline-block;">SEEK DWN</div> </td> <td>Scanning stops and a seek starts from the frequency being held.</td> </tr> <tr> <td style="text-align: center;"> <div style="border: 1px solid black; padding: 2px; display: inline-block;">MAN UP</div> <div style="border: 1px solid black; padding: 2px; display: inline-block;">MAN DWN</div> </td> <td>Scanning stops and operation of the <div style="border: 1px solid black; padding: 2px; display: inline-block;">MAN UP</div> or <div style="border: 1px solid black; padding: 2px; display: inline-block;">MAN DWN</div> key is performed from the frequency being held.</td> </tr> <tr> <td style="text-align: center;"> <div style="border: 1px solid black; padding: 2px; display: inline-block;">BAND</div> </td> <td> <p>Scanning stops and the band is switched sequentially as shown below.</p> <div style="text-align: center; margin: 10px 0;"> <div style="border: 1px solid black; padding: 5px; display: inline-block;"> → FM1 → FM2 → FM3 → MW1 → MW2 → LW → </div> </div> <p>However, bands disabled by receiving area and DISFM3, ENMW2 and DISLW switches are skipped. When switching returns to the same band, it returns to the held frequency.</p> </td> </tr> </tbody> </table> | Key | Operation | <div style="border: 1px solid black; padding: 2px; display: inline-block;">SCAN UP</div> <div style="border: 1px solid black; padding: 2px; display: inline-block;">SCAN DWN</div> | <ul style="list-style-type: none"> - <div style="border: 1px solid black; padding: 2px; display: inline-block;">SCAN UP</div> key during scan up and <div style="border: 1px solid black; padding: 2px; display: inline-block;">SCAN DWN</div> Key during scan down Scanning stops and the frequency being held is locked in. - <div style="border: 1px solid black; padding: 2px; display: inline-block;">SCAN DWN</div> key during scan up and <div style="border: 1px solid black; padding: 2px; display: inline-block;">SCAN UP</div> key during scan down And then the operation of the pressed key is performed. | <div style="border: 1px solid black; padding: 2px; display: inline-block;">SEEK UP</div> <div style="border: 1px solid black; padding: 2px; display: inline-block;">SEEK DWN</div> | Scanning stops and a seek starts from the frequency being held. | <div style="border: 1px solid black; padding: 2px; display: inline-block;">MAN UP</div> <div style="border: 1px solid black; padding: 2px; display: inline-block;">MAN DWN</div> | Scanning stops and operation of the <div style="border: 1px solid black; padding: 2px; display: inline-block;">MAN UP</div> or <div style="border: 1px solid black; padding: 2px; display: inline-block;">MAN DWN</div> key is performed from the frequency being held. | <div style="border: 1px solid black; padding: 2px; display: inline-block;">BAND</div> | <p>Scanning stops and the band is switched sequentially as shown below.</p> <div style="text-align: center; margin: 10px 0;"> <div style="border: 1px solid black; padding: 5px; display: inline-block;"> → FM1 → FM2 → FM3 → MW1 → MW2 → LW → </div> </div> <p>However, bands disabled by receiving area and DISFM3, ENMW2 and DISLW switches are skipped. When switching returns to the same band, it returns to the held frequency.</p> |
| Key | Operation | | | | | | | | | | |
| <div style="border: 1px solid black; padding: 2px; display: inline-block;">SCAN UP</div> <div style="border: 1px solid black; padding: 2px; display: inline-block;">SCAN DWN</div> | <ul style="list-style-type: none"> - <div style="border: 1px solid black; padding: 2px; display: inline-block;">SCAN UP</div> key during scan up and <div style="border: 1px solid black; padding: 2px; display: inline-block;">SCAN DWN</div> Key during scan down Scanning stops and the frequency being held is locked in. - <div style="border: 1px solid black; padding: 2px; display: inline-block;">SCAN DWN</div> key during scan up and <div style="border: 1px solid black; padding: 2px; display: inline-block;">SCAN UP</div> key during scan down And then the operation of the pressed key is performed. | | | | | | | | | | |
| <div style="border: 1px solid black; padding: 2px; display: inline-block;">SEEK UP</div> <div style="border: 1px solid black; padding: 2px; display: inline-block;">SEEK DWN</div> | Scanning stops and a seek starts from the frequency being held. | | | | | | | | | | |
| <div style="border: 1px solid black; padding: 2px; display: inline-block;">MAN UP</div> <div style="border: 1px solid black; padding: 2px; display: inline-block;">MAN DWN</div> | Scanning stops and operation of the <div style="border: 1px solid black; padding: 2px; display: inline-block;">MAN UP</div> or <div style="border: 1px solid black; padding: 2px; display: inline-block;">MAN DWN</div> key is performed from the frequency being held. | | | | | | | | | | |
| <div style="border: 1px solid black; padding: 2px; display: inline-block;">BAND</div> | <p>Scanning stops and the band is switched sequentially as shown below.</p> <div style="text-align: center; margin: 10px 0;"> <div style="border: 1px solid black; padding: 5px; display: inline-block;"> → FM1 → FM2 → FM3 → MW1 → MW2 → LW → </div> </div> <p>However, bands disabled by receiving area and DISFM3, ENMW2 and DISLW switches are skipped. When switching returns to the same band, it returns to the held frequency.</p> | | | | | | | | | | |

| Symbol | Function |
|----------------|---|
| Key | Operation |
| | <p>- When the M2S switch is 1, this key is invalid. - When M2S switch = 0 Each time the key is pressed, the memory write state is inverted as shown below.</p> <p>(i)</p> <p>(ii)</p> <p>When a M1 (TP1) to M6 key is pressed in the memory writable state, data is written to the present memory corresponding to the pressed key.</p> |
| ME | |
| SCAN UP | |
| SCAN DWN | |
| VF | Scanning is canceled and the key operation is performed. |
| PSCAN AMEMO | Scanning is canceled and the key operation is performed. |
| LOUD | The operation of the pressed key is performed. |
| LOC (TP4) | Scanning continues. |
| MONO (TP5) | |

| Symbol | Function | | | | | | | | |
|--|---|-----|-----------|--|--|--|---|--|---|
| <div style="display: flex; flex-direction: column; align-items: center; gap: 10px;"> <div style="border: 1px solid black; padding: 2px 5px;">SCAN UP</div> <div style="border: 1px solid black; padding: 2px 5px;">SCAN DWN</div> <div style="border: 1px solid black; padding: 2px 5px;">M1 (TP1)</div> <div style="border: 1px solid black; padding: 2px 5px;">M2 (TP2)</div> <div style="border: 1px solid black; padding: 2px 5px;">M3 (TP3)</div> <div style="border: 1px solid black; padding: 2px 5px;">M4</div> <div style="border: 1px solid black; padding: 2px 5px;">M5</div> <div style="border: 1px solid black; padding: 2px 5px;">M6</div> </div> | <table border="1" style="width: 100%; border-collapse: collapse;"> <thead> <tr> <th style="width: 15%;">Key</th> <th style="width: 85%;">Operation</th> </tr> </thead> <tbody> <tr> <td></td> <td> <ul style="list-style-type: none"> When M2S switch = 0 <ul style="list-style-type: none"> Memory unwriteable state. The scanning operation is canceled and the preset memory contents corresponding to the pressed key is called. Memory writable state (See the ME key below.) The held frequency is written to the preset memory corresponding to the pressed key and the memory writable state is canceled. Then, the hold state is held for 2 seconds. If an operation is not performed during this time, the next station is searched. <p>(Example)</p> </td> </tr> <tr> <td></td> <td> <ul style="list-style-type: none"> When M2S switch = 1 <ul style="list-style-type: none"> When key released within 2 seconds The preset memory contents corresponding to the pressed key are called and the scan operation is reset the moment the key is released. <p>(Example)</p> </td> </tr> <tr> <td></td> <td> <ul style="list-style-type: none"> When key pressed for more than 2 seconds The held frequency is written to the preset memory corresponding to the pressed key 2 seconds after the key has been passed for 2 seconds. 2 seconds after the end of writing, hold ends and the next station is searched (seek operation). <p>(Example)</p> </td> </tr> </tbody> </table> | Key | Operation | | <ul style="list-style-type: none"> When M2S switch = 0 <ul style="list-style-type: none"> Memory unwriteable state. The scanning operation is canceled and the preset memory contents corresponding to the pressed key is called. Memory writable state (See the ME key below.) The held frequency is written to the preset memory corresponding to the pressed key and the memory writable state is canceled. Then, the hold state is held for 2 seconds. If an operation is not performed during this time, the next station is searched. <p>(Example)</p> | | <ul style="list-style-type: none"> When M2S switch = 1 <ul style="list-style-type: none"> When key released within 2 seconds The preset memory contents corresponding to the pressed key are called and the scan operation is reset the moment the key is released. <p>(Example)</p> | | <ul style="list-style-type: none"> When key pressed for more than 2 seconds The held frequency is written to the preset memory corresponding to the pressed key 2 seconds after the key has been passed for 2 seconds. 2 seconds after the end of writing, hold ends and the next station is searched (seek operation). <p>(Example)</p> |
| Key | Operation | | | | | | | | |
| | <ul style="list-style-type: none"> When M2S switch = 0 <ul style="list-style-type: none"> Memory unwriteable state. The scanning operation is canceled and the preset memory contents corresponding to the pressed key is called. Memory writable state (See the ME key below.) The held frequency is written to the preset memory corresponding to the pressed key and the memory writable state is canceled. Then, the hold state is held for 2 seconds. If an operation is not performed during this time, the next station is searched. <p>(Example)</p> | | | | | | | | |
| | <ul style="list-style-type: none"> When M2S switch = 1 <ul style="list-style-type: none"> When key released within 2 seconds The preset memory contents corresponding to the pressed key are called and the scan operation is reset the moment the key is released. <p>(Example)</p> | | | | | | | | |
| | <ul style="list-style-type: none"> When key pressed for more than 2 seconds The held frequency is written to the preset memory corresponding to the pressed key 2 seconds after the key has been passed for 2 seconds. 2 seconds after the end of writing, hold ends and the next station is searched (seek operation). <p>(Example)</p> | | | | | | | | |

| Symbol | Function | | | | | | |
|--|--|-----|-----------|--|--|---|-----------------------|
| <div style="border: 1px solid black; padding: 2px; width: fit-content; margin: 10px auto;">BAND</div> | <p>Receiving band selection switch It is valid only in the radio mode. Each time this switch is pressed, the band is switched sequentially as shown below.</p> <div style="text-align: center; margin: 10px 0;"> </div> <p>However, bands disabled by receiving area and DISFM3, ENMW2, and DISLW switches are skipped. When the band is switched (FM1 → FM2 → FM3 → MW1 → MW2) in the same band (FM, MW), the band display and last channel change. When the <div style="border: 1px solid black; padding: 2px; display: inline-block;">BAND</div> key is pressed during VF band reception, the VF band is reset and the device returns to the band received last.</p> | | | | | | |
| <div style="border: 1px solid black; padding: 2px; width: fit-content; margin: 10px auto;">ME</div> | <p>In the radio mode, during frequency display, this key is used as the preset memory writable state setting key and during clock display (CE = High), this key is used with the <div style="border: 1px solid black; padding: 2px; display: inline-block;">MAN UP</div> and <div style="border: 1px solid black; padding: 2px; display: inline-block;">MAN DWN</div> keys as the clock adjustment key. When the M2S = 0, this key operates as the preset memory writable state and clock adjustment key. When M2S = 1, this key operates as the preset memory writable state and clock adjustment key. When M2S = 0, use the <div style="border: 1px solid black; padding: 2px; display: inline-block;">DISP</div> key to switch the display. This key operation is described below.</p> <ul style="list-style-type: none"> • Radio mode frequency display <ul style="list-style-type: none"> This key is used as the preset memory writable state setting key. It is valid only when the initialized diode M2S switch is 0. When this key is pressed, the device enters the preset memory writable state for 5 seconds and the current receiving frequency is written to the preset memory corresponding to the pressed key by pressing the <div style="border: 1px solid black; padding: 2px; display: inline-block;">M1 (TP1)</div> to <div style="border: 1px solid black; padding: 2px; display: inline-block;">M6</div> key. If the <div style="border: 1px solid black; padding: 2px; display: inline-block;">ME</div> key is pressed continuously at this time, the write operation is not performed. During the preset memory writable state, the "ch" display flashes at 1 Hz (duty 50%). If preset memory is being received, the preset memory number flashes also. This key is invalid during the seek operation (including seek operation at scanning). However, it is valid at 5 seconds hold during the preset memory scan and scan operations. Each key operation in the preset memory writable state is shown below. <table border="1" style="width: 100%; margin-top: 20px;"> <thead> <tr> <th style="width: 20%;">Key</th> <th>Operation</th> </tr> </thead> <tbody> <tr> <td style="text-align: center;"> <div style="border: 1px solid black; padding: 2px; display: inline-block;">M1 (TP1)</div> to <div style="border: 1px solid black; padding: 2px; display: inline-block;">M6</div> </td> <td>The frequency being received when a key is pressed is written to the preset memory corresponding to the pressed key.</td> </tr> <tr> <td style="text-align: center;"><div style="border: 1px solid black; padding: 2px; display: inline-block;">M6</div></td> <td>Muting is not output.</td> </tr> </tbody> </table> | Key | Operation | <div style="border: 1px solid black; padding: 2px; display: inline-block;">M1 (TP1)</div> to <div style="border: 1px solid black; padding: 2px; display: inline-block;">M6</div> | The frequency being received when a key is pressed is written to the preset memory corresponding to the pressed key. | <div style="border: 1px solid black; padding: 2px; display: inline-block;">M6</div> | Muting is not output. |
| Key | Operation | | | | | | |
| <div style="border: 1px solid black; padding: 2px; display: inline-block;">M1 (TP1)</div> to <div style="border: 1px solid black; padding: 2px; display: inline-block;">M6</div> | The frequency being received when a key is pressed is written to the preset memory corresponding to the pressed key. | | | | | | |
| <div style="border: 1px solid black; padding: 2px; display: inline-block;">M6</div> | Muting is not output. | | | | | | |

| Symbol | Function | |
|--------|--|--|
| | Key | Operation |
| | <div style="border: 1px solid black; padding: 2px; margin-bottom: 2px; text-align: center;">VF</div> <div style="border: 1px solid black; padding: 2px; margin-bottom: 2px; text-align: center;">PSCAN AMEMO</div> <div style="border: 1px solid black; padding: 2px; margin-bottom: 2px; text-align: center;">SEEK UP</div> <div style="border: 1px solid black; padding: 2px; margin-bottom: 2px; text-align: center;">SEEK DWN</div> <div style="border: 1px solid black; padding: 2px; margin-bottom: 2px; text-align: center;">SCAN UP</div> <div style="border: 1px solid black; padding: 2px; margin-bottom: 2px; text-align: center;">SCAN DWN</div> <div style="border: 1px solid black; padding: 2px; margin-bottom: 2px; text-align: center;">MAN UP</div> <div style="border: 1px solid black; padding: 2px; margin-bottom: 2px; text-align: center;">MAN DWN</div> <div style="border: 1px solid black; padding: 2px; margin-bottom: 2px; text-align: center;">DISP</div> | Preset memory write mode is reset and each key operation is performed. |
| | <div style="border: 1px solid black; padding: 2px; text-align: center;">BAND</div> | The preset memory writable state is reset and the band is switched sequentially as shown below. <div style="text-align: center; margin: 10px 0;"> FM1 → FM2 → FM3 → MW1 → MW2 → LW </div> However, bands disabled by receiving area and DISFM3, ENMW2 and DISLW switches are skipped. |
| | <div style="border: 1px solid black; padding: 2px; text-align: center;">ME</div> | The preset memory writable state is reset. |
| ME | <div style="border: 1px solid black; padding: 2px; margin-bottom: 2px; text-align: center;">LOUD</div> <div style="border: 1px solid black; padding: 2px; margin-bottom: 2px; text-align: center;">LOC (TP4)</div> <div style="border: 1px solid black; padding: 2px; margin-bottom: 2px; text-align: center;">MONO (TP5)</div> | The preset memory writable state is held and each key operation is performed. |

Keys other than those described above (except the POWER key) are invalid.

When the radio is turned off and then turned back on (including tape and CD mode switching) in the preset memory writable state, the writable state is released.

- Clock display

This key is used as the time adjustment key.

The minute and hour digits are adjusted as shown below by pressing the MAN UP and MAN DWN keys while pressing the ME key.

- Hour adjustment

The hour is advanced one hour each time the MAN DWN key is pressed. When the key is held down for more than 0.5 seconds, the hour changes continuously at a speed of 4 hours/sec (1 hour in 250 ms) until the key is released.

The minute digit and seconds count are not affected.

- Minute digit adjustment

The minute digit is advanced one minute each time the MAN UP key is pressed.

When the key held down for more than 0.5 seconds, the minute digit changes at a speed of 8 minutes/sec (1 minute in 125 ms) until the key is released. Carry to the hour digit is not performed. Each time the minute-digit is adjusted, the seconds count is reset.

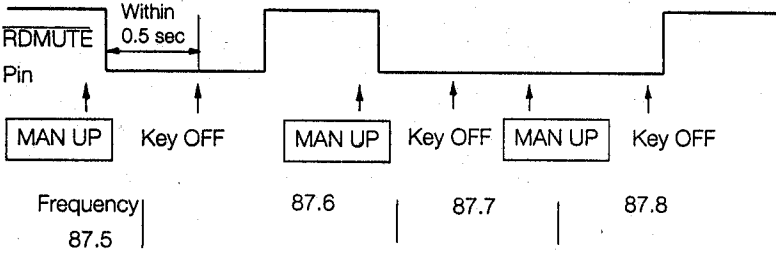
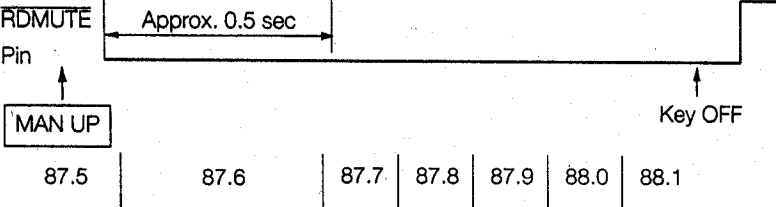
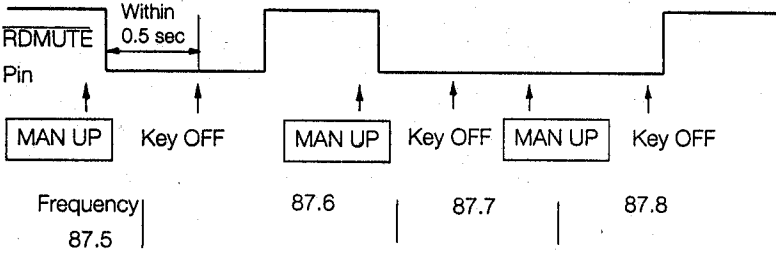
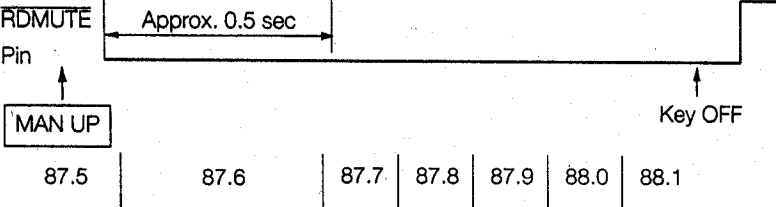
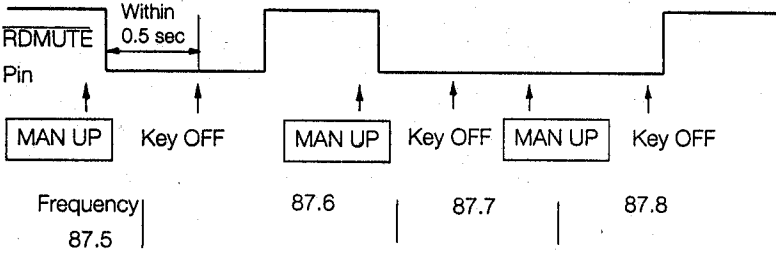
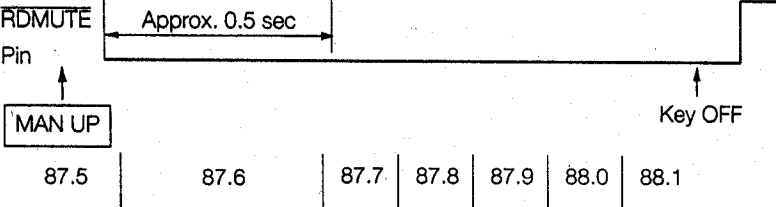
| Symbol | Function | | | | |
|--|--|---------|-------------|---|--|
| | <p>In the radio mode, these keys are used as the receiving frequency up/down keys. During clock display, these keys are used with the ME key as the clock adjustment keys.</p> <p>Their operation is shown below.</p> | | | | |
| <ul style="list-style-type: none"> Radio mode | <p>These keys operate as shown below, depending on the setting of the initialized diode matrix AUTO 500 switch.</p> <p>- Operation by AUTO 500 switch</p> | | | | |
| | <table border="1"> <thead> <tr> <th data-bbox="366 604 463 636">AUTO500</th> <th data-bbox="840 611 951 642">Description</th> </tr> </thead> <tbody> <tr> <td data-bbox="417 1003 432 1024">0</td> <td data-bbox="535 663 1341 1388"> <p>Each time a key is pressed, the frequency is incremented (MAN UP key) or decremented (MAN DWN key) one step (1 channel space). When the key is held down for approx. 0.5 seconds, the frequency changes continuously at a speed of approx. 50 ms per step until the key is released.</p> <p>Example 1) When key released within 0.5 seconds</p>  <p>Example 2) When key held down for more than 0.5 seconds</p>  </td> </tr> </tbody> </table> | AUTO500 | Description | 0 | <p>Each time a key is pressed, the frequency is incremented (MAN UP key) or decremented (MAN DWN key) one step (1 channel space). When the key is held down for approx. 0.5 seconds, the frequency changes continuously at a speed of approx. 50 ms per step until the key is released.</p> <p>Example 1) When key released within 0.5 seconds</p>  <p>Example 2) When key held down for more than 0.5 seconds</p>  |
| AUTO500 | Description | | | | |
| 0 | <p>Each time a key is pressed, the frequency is incremented (MAN UP key) or decremented (MAN DWN key) one step (1 channel space). When the key is held down for approx. 0.5 seconds, the frequency changes continuously at a speed of approx. 50 ms per step until the key is released.</p> <p>Example 1) When key released within 0.5 seconds</p>  <p>Example 2) When key held down for more than 0.5 seconds</p>  | | | | |

MAN UP

MAN DWN

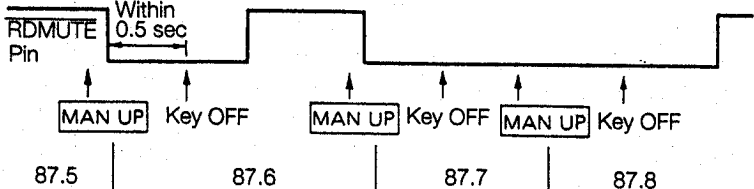
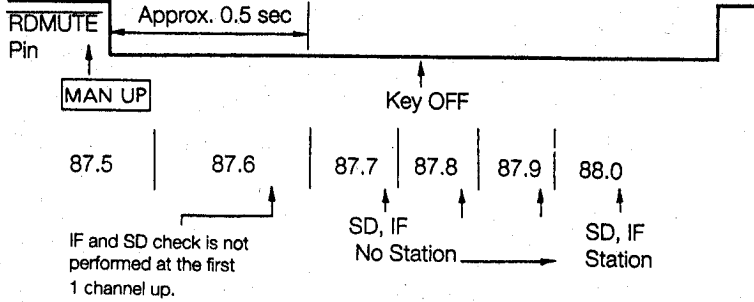
| Symbol | Function |
|--|---|
| AUTO 500 | Description |
| 1 | <p>Each time a key is pressed, the frequency is incremented (MAN UP Key) or decremented (MAN DWN key) one step. When the key is held down for more than 0.5 seconds, the seek operation (seek up for MAN UP and seek down for MAN DWN) starts at the point after 0.5 seconds. This seek operation is the same as that of the SEEK UP and SEEK DWN keys. After the key was held down for more than 0.5 seconds, the seek operation continues even if the key is released.</p> <p>Example 1) When key released within 0.5 seconds</p>  <p>Example 2) When key held down for more than 0.5 seconds</p>  <p>When the AUTO 500 switch was set to 1, do not use the SEEK UP and SEEK DWN keys.</p> |
| <p>MAN UP</p> <p>MAN DWN</p> | <p>· During clock display</p> <p>When the clock is displayed and the ME key was pressed and held, the minute and hour digits are adjusted by pressing the MAN UP and MAN DWN keys.</p> <p>For a description of the minute and hour digits adjustment method, see the ME key above.</p> |
| LOUD | <p>LOUD (LOUDNESS) control key.</p> <p>It is valid in the radio, tape and CD modes.</p> <p>Each time this key is pressed, the LCD panel "LOUD" display and the LOUD pin (pin 19) output are inverted.</p> <p>The LOUD state is held even when radio, tape and CD mode switching is performed.</p> <p>When the power is turned on, the OFF state is set ("LOUD" display OFF, LOUD pin Low level).</p> |

| Symbol | Function |
|--|--|
| <div style="border: 1px solid black; padding: 2px; width: fit-content;">LOC (TP4)</div> | <p>The LOC(TP4) key is used as a LOCAL (LOCAL/DX) control key when in the radio mode and as a tape function key when in the tape mode in conjunction with initialization diode switches.</p> <ul style="list-style-type: none"> - In the radio mode <ul style="list-style-type: none"> The LCD panel "LOC" indicator and the output on the LOC pin (pin 10) are inverted each time the key is pressed. A high is output on the LOC pin while the "LOC" indicator is on - In the tape mode <ul style="list-style-type: none"> The LOC(TP4) key can be used as an AMS, NR (NOISE REDUCTION) or MTL (METAL) function key when the initialization diode switch ENTPK is "1". For the choice between AMS, NR and MTL functions, see the description of the initialization diode switches KAMS, KNR and KMTL. When the AMS, MTL or NR function is selected, the LOC(TP4) key operates the same way as <div style="display: flex; align-items: center; justify-content: center; margin: 10px 0;"> <div style="border: 1px solid black; padding: 2px 10px; margin-right: 10px;">AMS</div> or <div style="border: 1px solid black; padding: 2px 10px; margin-right: 10px;">MTL</div> or <div style="border: 1px solid black; padding: 2px 10px; margin-right: 10px;">NR</div> key. </div> <p>See the description of these keys.</p> |
| <div style="border: 1px solid black; padding: 2px; width: fit-content;">MONO (TP5)</div> | <p>In the radio mode, this key is used as the MONO control key. In the tape mode, this key is used as the tape function key by the initialized diode.</p> <ul style="list-style-type: none"> - Radio mode <ul style="list-style-type: none"> This key is valid only in FM and VF bands. Each time this key is pressed, the LCD panel "MONO" display and the MONO/NR₂ pin (pin 18) output the inverted. High level is output from the MONO/NR₂ pin while "MONO" is displayed. When the power is turned on, the OFF state is set ("MONO" display OFF, MONO/NR₂ pin Low level). - Tape mode <ul style="list-style-type: none"> This key can be used as the AMS, MTL or NR function key by the initialized diode ENTPK, KAMS, KNR, and KMTL switches. See the ENTPK, KAMS and KMTL switches items. When the AMS or MTL function is selected, this key operates the same as the <div style="display: flex; align-items: center; justify-content: center; margin: 10px 0;"> <div style="border: 1px solid black; padding: 2px 10px; margin-right: 10px;">AMS</div> or <div style="border: 1px solid black; padding: 2px 10px; margin-right: 10px;">NR</div> key. <div style="border: 1px solid black; padding: 2px 10px; margin-left: 20px; margin-left: 20px;">MTL</div> </div> |
| <div style="border: 1px solid black; padding: 2px; width: fit-content;">MTL</div> | <p>MTL (METAL) control key.</p> <p>This key is valid in the tape mode.</p> <p>Each time this key is pressed, the LCD panel "MTL" display and the MTL pin (pin 21) output are inverted. High level is output from the LOC/MTL pin while "MTL" is displayed.</p> <p>When the power is turned on, the OFF state is set ("MTL" display OFF, MTL pin Low level).</p> |

| Symbol | Function | | | | | | | | | | | | |
|---|--|---|---------------|---|---|---|--|---|---|---|---|---|--|
| <p style="text-align: center; border: 1px solid black; padding: 2px;">NR</p> | <p>NR₁ (NOISE REDUCTION) and NR₂ control key. This key is valid in the tape mode. Its operation depends on the setting of the initialized diode ENNR₂ switch as shown below.</p> <table border="1" style="width: 100%; border-collapse: collapse;"> <thead> <tr> <th style="width: 15%;">ENNR₂</th> <th style="width: 85%;">Key Operation</th> </tr> </thead> <tbody> <tr> <td style="text-align: center; vertical-align: middle;">0</td> <td> <p>Each time this key is pressed, the LCD panel "NR₁" display and the NR₁ pin (pin 22) output are inverted. High level is output from the NR₁ pin while "NR₁" is displayed. When the power is turned on, the OFF state is set ("NR₁" display OFF, NR₁ pin Low level).</p> </td> </tr> <tr> <td style="text-align: center; vertical-align: middle;">1</td> <td> <p>Each time this key is pressed, the display and output are switched as shown below.</p> <div style="text-align: center; border: 1px solid black; padding: 10px; margin: 10px auto; width: 80%;"> <table style="width: 100%; border-collapse: collapse;"> <tr> <td style="width: 50%; text-align: center;"> "NR₁" display OFF NR₁ pin Low "NR₂" display OFF MONO/NR₂ pin LOW </td> <td style="width: 10%; text-align: center; vertical-align: middle;">→</td> <td style="width: 40%; text-align: center;"> "NR₁" display ON NR₁ pin High "NR₂" display OFF MONO/NR₂ pin LOW </td> </tr> <tr> <td style="width: 50%; text-align: center;"> "NR₁" display OFF NR₁ pin LOW "NR₂" display ON MONO/NR₂ pin HIGH </td> <td style="width: 10%; text-align: center; vertical-align: middle;">←</td> <td style="width: 40%;"></td> </tr> </table> </div> <p>When the power is turned on, NR₁ and NR₂ are both turned off.</p> </td> </tr> </tbody> </table> | ENNR ₂ | Key Operation | 0 | <p>Each time this key is pressed, the LCD panel "NR₁" display and the NR₁ pin (pin 22) output are inverted. High level is output from the NR₁ pin while "NR₁" is displayed. When the power is turned on, the OFF state is set ("NR₁" display OFF, NR₁ pin Low level).</p> | 1 | <p>Each time this key is pressed, the display and output are switched as shown below.</p> <div style="text-align: center; border: 1px solid black; padding: 10px; margin: 10px auto; width: 80%;"> <table style="width: 100%; border-collapse: collapse;"> <tr> <td style="width: 50%; text-align: center;"> "NR₁" display OFF NR₁ pin Low "NR₂" display OFF MONO/NR₂ pin LOW </td> <td style="width: 10%; text-align: center; vertical-align: middle;">→</td> <td style="width: 40%; text-align: center;"> "NR₁" display ON NR₁ pin High "NR₂" display OFF MONO/NR₂ pin LOW </td> </tr> <tr> <td style="width: 50%; text-align: center;"> "NR₁" display OFF NR₁ pin LOW "NR₂" display ON MONO/NR₂ pin HIGH </td> <td style="width: 10%; text-align: center; vertical-align: middle;">←</td> <td style="width: 40%;"></td> </tr> </table> </div> <p>When the power is turned on, NR₁ and NR₂ are both turned off.</p> | "NR ₁ " display OFF NR ₁ pin Low "NR ₂ " display OFF MONO/NR ₂ pin LOW | → | "NR ₁ " display ON NR ₁ pin High "NR ₂ " display OFF MONO/NR ₂ pin LOW | "NR ₁ " display OFF NR ₁ pin LOW "NR ₂ " display ON MONO/NR ₂ pin HIGH | ← | |
| ENNR ₂ | Key Operation | | | | | | | | | | | | |
| 0 | <p>Each time this key is pressed, the LCD panel "NR₁" display and the NR₁ pin (pin 22) output are inverted. High level is output from the NR₁ pin while "NR₁" is displayed. When the power is turned on, the OFF state is set ("NR₁" display OFF, NR₁ pin Low level).</p> | | | | | | | | | | | | |
| 1 | <p>Each time this key is pressed, the display and output are switched as shown below.</p> <div style="text-align: center; border: 1px solid black; padding: 10px; margin: 10px auto; width: 80%;"> <table style="width: 100%; border-collapse: collapse;"> <tr> <td style="width: 50%; text-align: center;"> "NR₁" display OFF NR₁ pin Low "NR₂" display OFF MONO/NR₂ pin LOW </td> <td style="width: 10%; text-align: center; vertical-align: middle;">→</td> <td style="width: 40%; text-align: center;"> "NR₁" display ON NR₁ pin High "NR₂" display OFF MONO/NR₂ pin LOW </td> </tr> <tr> <td style="width: 50%; text-align: center;"> "NR₁" display OFF NR₁ pin LOW "NR₂" display ON MONO/NR₂ pin HIGH </td> <td style="width: 10%; text-align: center; vertical-align: middle;">←</td> <td style="width: 40%;"></td> </tr> </table> </div> <p>When the power is turned on, NR₁ and NR₂ are both turned off.</p> | "NR ₁ " display OFF NR ₁ pin Low "NR ₂ " display OFF MONO/NR ₂ pin LOW | → | "NR ₁ " display ON NR ₁ pin High "NR ₂ " display OFF MONO/NR ₂ pin LOW | "NR ₁ " display OFF NR ₁ pin LOW "NR ₂ " display ON MONO/NR ₂ pin HIGH | ← | | | | | | | |
| "NR ₁ " display OFF NR ₁ pin Low "NR ₂ " display OFF MONO/NR ₂ pin LOW | → | "NR ₁ " display ON NR ₁ pin High "NR ₂ " display OFF MONO/NR ₂ pin LOW | | | | | | | | | | | |
| "NR ₁ " display OFF NR ₁ pin LOW "NR ₂ " display ON MONO/NR ₂ pin HIGH | ← | | | | | | | | | | | | |
| <p style="text-align: center; border: 1px solid black; padding: 2px;">AMS</p> | <p>AMS (AUTO MUSIC SEARCH) control key. This key is valid in the tape mode. Each time this key is pressed, the LCD panel "AMS" display and the AMS pin (pin 20) output are inverted. High level is output from the AMS pin while "AMS" is displayed. When the AMS pin is high level (AMS mode), if the TPSET switch is ON, the AMS pin holds the high level output even if the mode is switched to the CD or radio mode. When the power is turned on, AMS is turned off ("AMS" display OFF, AMS pin Low level).</p> | | | | | | | | | | | | |
| <p style="text-align: center; border: 1px solid black; padding: 2px;">RDMONI</p> | <p>Radio monitor key. This key is valid in the tape and CD modes. Each time this key is pressed, the radio monitor mode is inverted. In the radio monitor mode, the LCD panel "RDMONI" display lights. In the radio monitor mode, all band tuning operations are possible and radio muting (RDMUTE pin) is turned off and audio muting (AMUTE pin) is turned on.</p> | | | | | | | | | | | | |

| Symbol | Function | | | | | | | | | | | | | | | | | | | | | | | | | | | | | | | | |
|--------|--|--|---|------------------|-------------|---|---|------|--|---|---|-------------------|---|---|---|---------------|---|-------|-------|------------------|-------------|---|---|------|---|---|---|--|---|---|---|-------|---|
| DISP | <p>Display switching key.</p> <p>This key is valid when the initialized diode NOCLK = 0 (clock), M2S = 0</p> <p>The display switching operation is shown below.</p> <ul style="list-style-type: none"> • Raio mode <p>Each time this key is pressed, the frequency display and clock display are switched.</p> <p>This key is invalid at seek, scan and auto preset scan.</p> <p>Operation according to the setting of the initialized diode PRIO1 and PRIO 2 switches is shown below.</p> <table border="1" style="width: 100%; border-collapse: collapse;"> <thead> <tr> <th style="width: 10%;">PRIO1</th> <th style="width: 10%;">PRIO2</th> <th style="width: 15%;">Priority Display</th> <th>Description</th> </tr> </thead> <tbody> <tr> <td style="text-align: center;">0</td> <td style="text-align: center;">0</td> <td style="text-align: center;">None</td> <td>Each time the DISP key is pressed, the frequency display and clock display are switched.</td> </tr> <tr> <td style="text-align: center;">0</td> <td style="text-align: center;">1</td> <td style="text-align: center;">Frequency display</td> <td>When the DISP key is pressed during frequency display, the clock is displayed for 5 seconds. When the DISP key is pressed during the 5 seconds clock display, the display returns to the frequency display.</td> </tr> <tr> <td style="text-align: center;">1</td> <td style="text-align: center;">0</td> <td style="text-align: center;">Clock display</td> <td>When the DISP key is pressed during clock display, the frequency display is displayed for 5 seconds. When the DISP key is pressed during the 5 seconds frequency display, the display returns to the clock display.</td> </tr> </tbody> </table> <p>When the device is switched to the radio mode, display starts from frequency display.</p> <ul style="list-style-type: none"> • Tape mode <p>The DISP Key is invalid.</p> <ul style="list-style-type: none"> • CD mode <p>Each time this key is pressed, the CD display and clock display are switched.</p> <p>Operation according to the setting of the initialized diodes PRIO1 and PRIO2 is shown below.</p> <table border="1" style="width: 100%; border-collapse: collapse;"> <thead> <tr> <th style="width: 10%;">PRIO1</th> <th style="width: 10%;">PRIO2</th> <th style="width: 15%;">Priority Display</th> <th>Description</th> </tr> </thead> <tbody> <tr> <td style="text-align: center;">0</td> <td style="text-align: center;">0</td> <td style="text-align: center;">None</td> <td>Each time the DISP key is pressed, the CD display and clock display are switched.</td> </tr> <tr> <td style="text-align: center;">0</td> <td style="text-align: center;">1</td> <td style="text-align: center;">CD display</td> <td>When the DISP key is pressed, during CD display, the clock is displayed for 5 seconds. When the DISP key is pressed during the 5 seconds clock display, the display returns to the CD display.</td> </tr> <tr> <td style="text-align: center;">1</td> <td style="text-align: center;">0</td> <td style="text-align: center;">Clock</td> <td>When the DISP key is pressed during clock display, the CD display is displayed for 5 seconds. When the DISP key is pressed during the 5 seconds CD display, the display returns to the CD display.</td> </tr> </tbody> </table> <p>When the device is switched to the CD mode, display starts from CD display.</p> | PRIO1 | PRIO2 | Priority Display | Description | 0 | 0 | None | Each time the DISP key is pressed, the frequency display and clock display are switched. | 0 | 1 | Frequency display | When the DISP key is pressed during frequency display, the clock is displayed for 5 seconds. When the DISP key is pressed during the 5 seconds clock display, the display returns to the frequency display. | 1 | 0 | Clock display | When the DISP key is pressed during clock display, the frequency display is displayed for 5 seconds. When the DISP key is pressed during the 5 seconds frequency display, the display returns to the clock display. | PRIO1 | PRIO2 | Priority Display | Description | 0 | 0 | None | Each time the DISP key is pressed, the CD display and clock display are switched. | 0 | 1 | CD display | When the DISP key is pressed, during CD display, the clock is displayed for 5 seconds. When the DISP key is pressed during the 5 seconds clock display, the display returns to the CD display. | 1 | 0 | Clock | When the DISP key is pressed during clock display, the CD display is displayed for 5 seconds. When the DISP key is pressed during the 5 seconds CD display, the display returns to the CD display. |
| | PRIO1 | PRIO2 | Priority Display | Description | | | | | | | | | | | | | | | | | | | | | | | | | | | | | |
| 0 | 0 | None | Each time the DISP key is pressed, the frequency display and clock display are switched. | | | | | | | | | | | | | | | | | | | | | | | | | | | | | | |
| 0 | 1 | Frequency display | When the DISP key is pressed during frequency display, the clock is displayed for 5 seconds. When the DISP key is pressed during the 5 seconds clock display, the display returns to the frequency display. | | | | | | | | | | | | | | | | | | | | | | | | | | | | | | |
| 1 | 0 | Clock display | When the DISP key is pressed during clock display, the frequency display is displayed for 5 seconds. When the DISP key is pressed during the 5 seconds frequency display, the display returns to the clock display. | | | | | | | | | | | | | | | | | | | | | | | | | | | | | | |
| PRIO1 | PRIO2 | Priority Display | Description | | | | | | | | | | | | | | | | | | | | | | | | | | | | | | |
| 0 | 0 | None | Each time the DISP key is pressed, the CD display and clock display are switched. | | | | | | | | | | | | | | | | | | | | | | | | | | | | | | |
| 0 | 1 | CD display | When the DISP key is pressed, during CD display, the clock is displayed for 5 seconds. When the DISP key is pressed during the 5 seconds clock display, the display returns to the CD display. | | | | | | | | | | | | | | | | | | | | | | | | | | | | | | |
| 1 | 0 | Clock | When the DISP key is pressed during clock display, the CD display is displayed for 5 seconds. When the DISP key is pressed during the 5 seconds CD display, the display returns to the CD display. | | | | | | | | | | | | | | | | | | | | | | | | | | | | | | |



| Symbol | Function |
|--|---|
| <div data-bbox="163 445 299 486" style="border: 1px solid black; padding: 2px; display: inline-block;">POWER</div> | <p>This key is used when turning the radio ON and OFF momentary key, controlling the illumination, etc.</p> <p>This key is valid only when the CE pin is High.</p> <p>The POWER pin (pin 23) output is inverted by pressing this key.</p> <p>When using this key, set the RDON switch (diode matrix) to 0.</p> <p>The radio is turned on and off by turning the transistor switch RDON ON and OFF with the output of the POWER pin.</p> <p>For details, see "Mode Transition" and "Application Circuits".</p> |



2.4.2 Alternate or Transistor Switch

| Symbol | Function | | | | | | | | | | | | | |
|--------|--|---------|----|---------|---|---|---|---|---|---|---|---|---|---|
| CDSET | <p>CD mode setting switch.</p> <p>This switch is valid only when the CE pin is high level.</p> <p>The CD mode can be set by setting this switch to ON.</p> <p>For details, see "Mode Transition".</p> | | | | | | | | | | | | | |
| TPSET | <p>Tape mode setting switch.</p> <p>This switch is valid only when the CE pin is high level.</p> <p>When this switch is set to ON when the CDSET is OFF, the device is set to the tape mode.</p> <p>For details, see "Mode Transition".</p> | | | | | | | | | | | | | |
| RDSET | <p>Radio mode setting switch.</p> <p>This switch is valid only when the CE pin is high level.</p> <p>When this switch is set to ON when the CDSET and TPSET switches are OFF, the device is set to the radio mode.</p> <p>For details, see "Mode Transition".</p> <p>When using this switch, set the RDON switch (diode matrix) to 0.</p> | | | | | | | | | | | | | |
| FF | <p>Tape mode fast forward signal input switch.</p> <p>The tape fast forward display (<▷) lights as shown below according to the state of the RL switch.</p> <table border="1" style="margin: 10px auto;"> <thead> <tr> <th>FF</th> <th>RL</th> <th>Display</th> </tr> </thead> <tbody> <tr> <td rowspan="2">0</td> <td>0</td> <td>◀</td> </tr> <tr> <td>1</td> <td>▶</td> </tr> <tr> <td rowspan="2">1</td> <td>0</td> <td>◁</td> </tr> <tr> <td>1</td> <td>▷</td> </tr> </tbody> </table> <p>◀ : Light ON, ◁ : Flash (2Hz) 0 : OFF, 1 : ON</p> | FF | RL | Display | 0 | 0 | ◀ | 1 | ▶ | 1 | 0 | ◁ | 1 | ▷ |
| FF | RL | Display | | | | | | | | | | | | |
| 0 | 0 | ◀ | | | | | | | | | | | | |
| | 1 | ▶ | | | | | | | | | | | | |
| 1 | 0 | ◁ | | | | | | | | | | | | |
| | 1 | ▷ | | | | | | | | | | | | |
| SK | <p>VF broadcast station SK signal input switch.</p> <p>When this switch is set to ON on the FM and VF bands, the LCD panel "SK" display lights. On the FM and VF bands this signal is also used as the auto tuning stop signal. At this time, 250 to 375 ms after the broadcast station is judged to be present by IF and SD pin, this switch is checked and if it is ON, a traffic information station is judged to be present and autotuning stops.</p> | | | | | | | | | | | | | |
| RL | <p>Tape mode travel direction signal input switch.</p> <p>The tape display (<▷) lights according to the state of the FF switch. For the lighting contents, see the FF switch above.</p> | | | | | | | | | | | | | |
| DK | <p>VF broadcast station DK signal input switch.</p> <p>When this switch is set to ON in the tape DK standby and CD DK standby modes, the device enters the tape DK ON and CD DK ON mode.</p> | | | | | | | | | | | | | |
| ST | <p>Switch used to enable "ST" display in the radio mode. "ST" display on the LCD panel lights by turning on this switch.</p> | | | | | | | | | | | | | |

2.4.3 Diode Matrix

| Symbol | Function | | | | | | | | | | | | | | | | | | | | | | | | | | | | | | | | | | | | | | | | | | | | | | | |
|--------------------------|---|--------|---------------------------|-------------------------|-------|-----------------|----------------------|---|---------|---|------------------------|---|----------|---|--------------------|---|---------|---|-------------------------|---|---------|---|-------------------|---|---------|---|---------------|---|------------------------|---|--------------------|----------------|-------|---|---|--------------------|---------------------------|---|---|-------------------------|---|---|---|---------------|---|---|---|--------------------|
| AREA1 AREA2 AREA3 | <p>Receiving area setting switch. Its setting is shown below. For the receiving frequencies, etc, at each area, see page 2.</p> <table border="1"> <thead> <tr> <th>AREA3</th> <th>AREA 2</th> <th>AREA 1</th> <th>MODE</th> </tr> </thead> <tbody> <tr> <td>0</td> <td>0</td> <td>0</td> <td>Europe1</td> </tr> <tr> <td>0</td> <td>0</td> <td>1</td> <td>Europe 2</td> </tr> <tr> <td>0</td> <td>1</td> <td>0</td> <td>U.S.A 1</td> </tr> <tr> <td>0</td> <td>1</td> <td>1</td> <td>U.S.A 2</td> </tr> <tr> <td>1</td> <td>0</td> <td>0</td> <td>U.S.A 3</td> </tr> <tr> <td>1</td> <td>0</td> <td>1</td> <td>Australia, Middle East</td> </tr> <tr> <td>1</td> <td>1</td> <td>0</td> <td>Japan</td> </tr> <tr> <td>1</td> <td>1</td> <td>1</td> <td>Central and South America</td> </tr> </tbody> </table> | AREA3 | AREA 2 | AREA 1 | MODE | 0 | 0 | 0 | Europe1 | 0 | 0 | 1 | Europe 2 | 0 | 1 | 0 | U.S.A 1 | 0 | 1 | 1 | U.S.A 2 | 1 | 0 | 0 | U.S.A 3 | 1 | 0 | 1 | Australia, Middle East | 1 | 1 | 0 | Japan | 1 | 1 | 1 | Central and South America | | | | | | | | | | | |
| AREA3 | AREA 2 | AREA 1 | MODE | | | | | | | | | | | | | | | | | | | | | | | | | | | | | | | | | | | | | | | | | | | | | |
| 0 | 0 | 0 | Europe1 | | | | | | | | | | | | | | | | | | | | | | | | | | | | | | | | | | | | | | | | | | | | | |
| 0 | 0 | 1 | Europe 2 | | | | | | | | | | | | | | | | | | | | | | | | | | | | | | | | | | | | | | | | | | | | | |
| 0 | 1 | 0 | U.S.A 1 | | | | | | | | | | | | | | | | | | | | | | | | | | | | | | | | | | | | | | | | | | | | | |
| 0 | 1 | 1 | U.S.A 2 | | | | | | | | | | | | | | | | | | | | | | | | | | | | | | | | | | | | | | | | | | | | | |
| 1 | 0 | 0 | U.S.A 3 | | | | | | | | | | | | | | | | | | | | | | | | | | | | | | | | | | | | | | | | | | | | | |
| 1 | 0 | 1 | Australia, Middle East | | | | | | | | | | | | | | | | | | | | | | | | | | | | | | | | | | | | | | | | | | | | | |
| 1 | 1 | 0 | Japan | | | | | | | | | | | | | | | | | | | | | | | | | | | | | | | | | | | | | | | | | | | | | |
| 1 | 1 | 1 | Central and South America | | | | | | | | | | | | | | | | | | | | | | | | | | | | | | | | | | | | | | | | | | | | | |
| DISFM3 ENMW2 DISLW | <p>Receiving band setting switch. Its setting is shown below</p> <ul style="list-style-type: none"> • DISFM3 FM3 band is disabled by setting to 1. • ENMW2..... MW2 band is enabled by setting to 1. • DISLW..... In Europe, the LW band is disabled by setting to 1. <p>The DISLW switch is invalid in areas outside of Europe. The receiving bands for each area are set with these switches as shown below.</p> <table border="1"> <thead> <tr> <th>AREA</th> <th>DISFM3</th> <th>ENMW2</th> <th>DISLW</th> <th>Receiving Bands</th> </tr> </thead> <tbody> <tr> <td rowspan="6">Europe1, Europe 2</td> <td>0</td> <td>0</td> <td>0</td> <td>FM1, FM2, FM3, MW1, LW</td> </tr> <tr> <td>0</td> <td>0</td> <td>1</td> <td>FM1, FM2, FM3, MW1</td> </tr> <tr> <td>0</td> <td>1</td> <td>—</td> <td>FM1, FM2, FM3, MW1, MW2</td> </tr> <tr> <td>1</td> <td>0</td> <td>0</td> <td>FM1, FM2, MW1, LW</td> </tr> <tr> <td>1</td> <td>0</td> <td>1</td> <td>FM1, FM2, MW1</td> </tr> <tr> <td>1</td> <td>1</td> <td>—</td> <td>FM1, FM2, MW1, MW2</td> </tr> <tr> <td rowspan="4">Other areas</td> <td>0</td> <td>0</td> <td>—</td> <td>FM1, FM2, FM3, MW1</td> </tr> <tr> <td>0</td> <td>1</td> <td>—</td> <td>FM1, FM2, FM3, MW1, MW2</td> </tr> <tr> <td>1</td> <td>0</td> <td>—</td> <td>FM1, FM2, MW1</td> </tr> <tr> <td>1</td> <td>1</td> <td>—</td> <td>FM1, FM2, MW1, MW2</td> </tr> </tbody> </table> <p style="text-align: right;">— : Don't care</p> | AREA | DISFM3 | ENMW2 | DISLW | Receiving Bands | Europe1, Europe 2 | 0 | 0 | 0 | FM1, FM2, FM3, MW1, LW | 0 | 0 | 1 | FM1, FM2, FM3, MW1 | 0 | 1 | — | FM1, FM2, FM3, MW1, MW2 | 1 | 0 | 0 | FM1, FM2, MW1, LW | 1 | 0 | 1 | FM1, FM2, MW1 | 1 | 1 | — | FM1, FM2, MW1, MW2 | Other areas | 0 | 0 | — | FM1, FM2, FM3, MW1 | 0 | 1 | — | FM1, FM2, FM3, MW1, MW2 | 1 | 0 | — | FM1, FM2, MW1 | 1 | 1 | — | FM1, FM2, MW1, MW2 |
| AREA | DISFM3 | ENMW2 | DISLW | Receiving Bands | | | | | | | | | | | | | | | | | | | | | | | | | | | | | | | | | | | | | | | | | | | | |
| Europe1, Europe 2 | 0 | 0 | 0 | FM1, FM2, FM3, MW1, LW | | | | | | | | | | | | | | | | | | | | | | | | | | | | | | | | | | | | | | | | | | | | |
| | 0 | 0 | 1 | FM1, FM2, FM3, MW1 | | | | | | | | | | | | | | | | | | | | | | | | | | | | | | | | | | | | | | | | | | | | |
| | 0 | 1 | — | FM1, FM2, FM3, MW1, MW2 | | | | | | | | | | | | | | | | | | | | | | | | | | | | | | | | | | | | | | | | | | | | |
| | 1 | 0 | 0 | FM1, FM2, MW1, LW | | | | | | | | | | | | | | | | | | | | | | | | | | | | | | | | | | | | | | | | | | | | |
| | 1 | 0 | 1 | FM1, FM2, MW1 | | | | | | | | | | | | | | | | | | | | | | | | | | | | | | | | | | | | | | | | | | | | |
| | 1 | 1 | — | FM1, FM2, MW1, MW2 | | | | | | | | | | | | | | | | | | | | | | | | | | | | | | | | | | | | | | | | | | | | |
| Other areas | 0 | 0 | — | FM1, FM2, FM3, MW1 | | | | | | | | | | | | | | | | | | | | | | | | | | | | | | | | | | | | | | | | | | | | |
| | 0 | 1 | — | FM1, FM2, FM3, MW1, MW2 | | | | | | | | | | | | | | | | | | | | | | | | | | | | | | | | | | | | | | | | | | | | |
| | 1 | 0 | — | FM1, FM2, MW1 | | | | | | | | | | | | | | | | | | | | | | | | | | | | | | | | | | | | | | | | | | | | |
| | 1 | 1 | — | FM1, FM2, MW1, MW2 | | | | | | | | | | | | | | | | | | | | | | | | | | | | | | | | | | | | | | | | | | | | |

| Symbol | Function | | | | | | |
|----------|--|----------|---|---|--|---|---|
| M2S | <p>Preset memory write method setting switch. Its setting is shown below.</p> <table border="1" data-bbox="397 377 1273 675"> <thead> <tr> <th data-bbox="397 377 494 422">M2S</th> <th data-bbox="494 377 1273 422">Write Method</th> </tr> </thead> <tbody> <tr> <td data-bbox="397 422 494 547">0</td> <td data-bbox="494 422 1273 547">Preset memory is written by pressing a <input type="text" value="M1 (TP1)"/> to <input type="text" value="M6"/> key in the 5 seconds memory write state by <input type="text" value="ME"/> key.</td> </tr> <tr> <td data-bbox="397 547 494 675">1</td> <td data-bbox="494 547 1273 675">Preset memory is written by holding down a <input type="text" value="M1 (TP1)"/> to <input type="text" value="M6"/> key for more than 2 seconds. The <input type="text" value="ME"/> key is invalid.</td> </tr> </tbody> </table> <p>For more information, see the <input type="text" value="ME"/> and <input type="text" value="M1 (TP1)"/> to <input type="text" value="M6"/> items.</p> | M2S | Write Method | 0 | Preset memory is written by pressing a <input type="text" value="M1 (TP1)"/> to <input type="text" value="M6"/> key in the 5 seconds memory write state by <input type="text" value="ME"/> key. | 1 | Preset memory is written by holding down a <input type="text" value="M1 (TP1)"/> to <input type="text" value="M6"/> key for more than 2 seconds. The <input type="text" value="ME"/> key is invalid. |
| M2S | Write Method | | | | | | |
| 0 | Preset memory is written by pressing a <input type="text" value="M1 (TP1)"/> to <input type="text" value="M6"/> key in the 5 seconds memory write state by <input type="text" value="ME"/> key. | | | | | | |
| 1 | Preset memory is written by holding down a <input type="text" value="M1 (TP1)"/> to <input type="text" value="M6"/> key for more than 2 seconds. The <input type="text" value="ME"/> key is invalid. | | | | | | |
| AUTO 500 | <p><input type="text" value="MAN UP"/> and <input type="text" value="MAN DWN"/> keys function setting switch. The <input type="text" value="MAN UP"/> and <input type="text" value="MAN DWN"/> keys can also be used as autotuning (seek operation) keys by means of this switch. The settings of this switch are shown below.</p> <table border="1" data-bbox="329 903 1340 1338"> <thead> <tr> <th data-bbox="329 903 480 961">AUTO 500</th> <th data-bbox="480 903 1340 961"><input type="text" value="MAN UP"/> , <input type="text" value="MAN DWN"/> Key Function</th> </tr> </thead> <tbody> <tr> <td data-bbox="329 961 480 1152">0</td> <td data-bbox="480 961 1340 1152">Manual tuning only. Each time the key is pressed, the channel is incremented or decremented by one. When the key is held down for more than 0.5 seconds, the channel is changed continuously and rapidly.</td> </tr> <tr> <td data-bbox="329 1152 480 1338">1</td> <td data-bbox="480 1152 1340 1338">Manual tuning and autotuning. Each time the key is pressed, the channel is incremented or decremented by one. When the key is held down for more than 0.5 seconds, autotuning (seek operation) is performed from the next channel.</td> </tr> </tbody> </table> | AUTO 500 | <input type="text" value="MAN UP"/> , <input type="text" value="MAN DWN"/> Key Function | 0 | Manual tuning only. Each time the key is pressed, the channel is incremented or decremented by one. When the key is held down for more than 0.5 seconds, the channel is changed continuously and rapidly. | 1 | Manual tuning and autotuning. Each time the key is pressed, the channel is incremented or decremented by one. When the key is held down for more than 0.5 seconds, autotuning (seek operation) is performed from the next channel. |
| AUTO 500 | <input type="text" value="MAN UP"/> , <input type="text" value="MAN DWN"/> Key Function | | | | | | |
| 0 | Manual tuning only. Each time the key is pressed, the channel is incremented or decremented by one. When the key is held down for more than 0.5 seconds, the channel is changed continuously and rapidly. | | | | | | |
| 1 | Manual tuning and autotuning. Each time the key is pressed, the channel is incremented or decremented by one. When the key is held down for more than 0.5 seconds, autotuning (seek operation) is performed from the next channel. | | | | | | |

| Symbol | Function | | | | | | |
|---------|---|-----------------------------|-----------------------------|---|--|---|--|
| AUTOSTP | <p>Switch used to set the condition to stop auto-tuning. The switch also allows auto-tuning to continue further when the presence of a station is determined during auto-tuning. The switch sets the auto-tuning stop conditions as follows:</p> | | | | | | |
| | <table border="1"> <thead> <tr> <th data-bbox="342 404 506 457">AUTOSTP</th> <th data-bbox="506 404 1335 457">Auto-tuning stop conditions</th> </tr> </thead> <tbody> <tr> <td data-bbox="342 457 506 670">0</td> <td data-bbox="506 457 1335 670"> <p>Whenever the presence of a station is determined from the IF counter (along with an SK signal from the station when in the VF mode), tuning locks in that station even if auto-tuning keys are held down.</p> </td> </tr> <tr> <td data-bbox="342 670 506 1160">1</td> <td data-bbox="506 670 1335 1160"> <p>Auto-tuning stops when the presence of a station is determined from the IF counter (along with an SK signal from the station when in the VF mode.) and when auto-tuning keys are released ; that is, auto-tuning won't stop as long as an auto-tuning key is pressed even when the presence of a station is detected.</p> <p>This switch is operative with all the auto-tuning keys. During the first auto-tuning with <input type="checkbox"/> VF key, however, tuning stops an detection of the presence of a station (along with an SK signal from the station) even while <input type="checkbox"/> VF key is pressed.</p> </td> </tr> </tbody> </table> | AUTOSTP | Auto-tuning stop conditions | 0 | <p>Whenever the presence of a station is determined from the IF counter (along with an SK signal from the station when in the VF mode), tuning locks in that station even if auto-tuning keys are held down.</p> | 1 | <p>Auto-tuning stops when the presence of a station is determined from the IF counter (along with an SK signal from the station when in the VF mode.) and when auto-tuning keys are released ; that is, auto-tuning won't stop as long as an auto-tuning key is pressed even when the presence of a station is detected.</p> <p>This switch is operative with all the auto-tuning keys. During the first auto-tuning with <input type="checkbox"/> VF key, however, tuning stops an detection of the presence of a station (along with an SK signal from the station) even while <input type="checkbox"/> VF key is pressed.</p> |
| | AUTOSTP | Auto-tuning stop conditions | | | | | |
| 0 | <p>Whenever the presence of a station is determined from the IF counter (along with an SK signal from the station when in the VF mode), tuning locks in that station even if auto-tuning keys are held down.</p> | | | | | | |
| 1 | <p>Auto-tuning stops when the presence of a station is determined from the IF counter (along with an SK signal from the station when in the VF mode.) and when auto-tuning keys are released ; that is, auto-tuning won't stop as long as an auto-tuning key is pressed even when the presence of a station is detected.</p> <p>This switch is operative with all the auto-tuning keys. During the first auto-tuning with <input type="checkbox"/> VF key, however, tuning stops an detection of the presence of a station (along with an SK signal from the station) even while <input type="checkbox"/> VF key is pressed.</p> | | | | | | |

| Symbol | Function | | | | | | | | | | | | | | |
|------------------|--|------------------|--|------------------|-------------|---|---|------|---|---|---|-----------------|--|--|--|
| PRIO 1 PRIO 2 | Priority display setting switch. "Priority display" is display that returns to the previous display if no operation is performed within 5 seconds after the display was switched. These switches are valid only when the NOCLK switch is set to 0 (clock mode) when the device is not in the DK standby mode and radio monitor is not used. Their settings are shown below. | | | | | | | | | | | | | | |
| | <table border="1"> <thead> <tr> <th data-bbox="319 451 409 527">PRIO1</th> <th data-bbox="409 451 500 527">PRIO2</th> <th data-bbox="500 451 632 527">Priority Display</th> <th data-bbox="632 451 1324 527">Description</th> </tr> </thead> <tbody> <tr> <td data-bbox="319 527 409 1064">0</td> <td data-bbox="409 527 500 1064">0</td> <td data-bbox="500 527 632 1064">None</td> <td data-bbox="632 527 1324 1064"> Display switching is performed when the <input type="checkbox"/> DISP key and melody selection key (during clock display) was operated. - Radio mode The display switches between frequency display and clock display each time the <input type="checkbox"/> DISP key is pressed. When the melody selection key is pressed during clock display, the display switches to frequency display. - Tape mode The <input type="checkbox"/> DISP key is disabled. - CD mode The display is switched between "<input type="checkbox"/> CD" display and clock display each time the <input type="checkbox"/> DISP key is pressed. </td> </tr> <tr> <td data-bbox="319 1064 409 1866">1</td> <td data-bbox="409 1064 500 1866">0</td> <td data-bbox="500 1064 632 1866">Frequency CD</td> <td data-bbox="632 1064 1324 1866"> When the display switched from frequency or "<input type="checkbox"/> CD" display to clock display by <input type="checkbox"/> DISP key, if no operation is performed within 5 seconds, the display returns to the original display. - Radio mode Normally the frequency is displayed. The display is switched to 5 seconds clock display by pressing the <input type="checkbox"/> DISP key. When the <input type="checkbox"/> DISP key is pressed again, or the melody selection key is pressed, during 5 seconds clock display, the display returns to frequency display. - Tape mode Clock display. The <input type="checkbox"/> DISP key is invalid. - CD mode Normally "<input type="checkbox"/> CD" is displayed. The display is switched to 5 seconds clock display by pressing the <input type="checkbox"/> DISP key. When the <input type="checkbox"/> DISP key is pressed again during 5 seconds clock display, the display returns to CD display. </td> </tr> </tbody> </table> | PRIO1 | PRIO2 | Priority Display | Description | 0 | 0 | None | Display switching is performed when the <input type="checkbox"/> DISP key and melody selection key (during clock display) was operated. - Radio mode The display switches between frequency display and clock display each time the <input type="checkbox"/> DISP key is pressed. When the melody selection key is pressed during clock display, the display switches to frequency display. - Tape mode The <input type="checkbox"/> DISP key is disabled. - CD mode The display is switched between " <input type="checkbox"/> CD" display and clock display each time the <input type="checkbox"/> DISP key is pressed. | 1 | 0 | Frequency CD | When the display switched from frequency or " <input type="checkbox"/> CD" display to clock display by <input type="checkbox"/> DISP key, if no operation is performed within 5 seconds, the display returns to the original display. - Radio mode Normally the frequency is displayed. The display is switched to 5 seconds clock display by pressing the <input type="checkbox"/> DISP key. When the <input type="checkbox"/> DISP key is pressed again, or the melody selection key is pressed, during 5 seconds clock display, the display returns to frequency display. - Tape mode Clock display. The <input type="checkbox"/> DISP key is invalid. - CD mode Normally " <input type="checkbox"/> CD" is displayed. The display is switched to 5 seconds clock display by pressing the <input type="checkbox"/> DISP key. When the <input type="checkbox"/> DISP key is pressed again during 5 seconds clock display, the display returns to CD display. | | |
| PRIO1 | PRIO2 | Priority Display | Description | | | | | | | | | | | | |
| 0 | 0 | None | Display switching is performed when the <input type="checkbox"/> DISP key and melody selection key (during clock display) was operated. - Radio mode The display switches between frequency display and clock display each time the <input type="checkbox"/> DISP key is pressed. When the melody selection key is pressed during clock display, the display switches to frequency display. - Tape mode The <input type="checkbox"/> DISP key is disabled. - CD mode The display is switched between " <input type="checkbox"/> CD" display and clock display each time the <input type="checkbox"/> DISP key is pressed. | | | | | | | | | | | | |
| 1 | 0 | Frequency CD | When the display switched from frequency or " <input type="checkbox"/> CD" display to clock display by <input type="checkbox"/> DISP key, if no operation is performed within 5 seconds, the display returns to the original display. - Radio mode Normally the frequency is displayed. The display is switched to 5 seconds clock display by pressing the <input type="checkbox"/> DISP key. When the <input type="checkbox"/> DISP key is pressed again, or the melody selection key is pressed, during 5 seconds clock display, the display returns to frequency display. - Tape mode Clock display. The <input type="checkbox"/> DISP key is invalid. - CD mode Normally " <input type="checkbox"/> CD" is displayed. The display is switched to 5 seconds clock display by pressing the <input type="checkbox"/> DISP key. When the <input type="checkbox"/> DISP key is pressed again during 5 seconds clock display, the display returns to CD display. | | | | | | | | | | | | |
| | | | | | | | | | | | | | | | |



| Symbol | Function | | | |
|------------------|----------|--------|------------------|---|
| PRIO 1 PRIO 2 | PRIO 1 | PRIO 2 | Priority Display | Description |
| | 0 | 1 | Clock | In the radio and CE modes, clock display has priority. - Radio mode Normally the clock is displayed. The display is switched to 5 seconds frequency display by pressing the DISP key or melody selection key. When the DISP key is pressed again during 5 seconds frequency display, the display returns to clock display. - Tape mode The DISP key is invalid. - CD mode Normally the clock is displayed. The display is switched to 5 seconds "⌂" display by pressing the DISP key. When the DISP key is pressed again during 5 seconds "⌂" display, the display returns to clock display. |
| | 1 | 1 | — | Do not set to this mode. |

"Frequency display" in the above means receiving frequency, receiving band, and preset memory display. Therefore, during radio reception, the "PSCAN", "SK", "VF", "ST", "MONO", "LOCAL" and "LOUD" displays light even at clock display.
 In the tape mode, the "LOUD", "MTL", "NR1", "NR2", "AMS" and "▷", "◁" displays also light at clock display.

| Symbol | Function | | | |
|------------------|----------|-----------------|--|---|
| PRIO 1 PRIO 2 | PRIO1 | PRIO2 | Priority Display | Description |
| | 0 | 0 | None | - Tape DK standby - Radio monitor The display switches between frequency display and clock display each time the DISP key is pressed. When the melody selection key is pressed during clock display, the display switches to frequency display. When the device entered the tape DK standby and radio monitor standby mode, frequency is displayed first. - CD DK standby - Radio monitor The display switches between frequency display, "[CD]" display and clock display each time the DISP key is pressed. When the melody selection key is pressed during "[CD]" display and clock display, the display switches to frequency display. When the device entered the CD DK standby and radio monitor mode, frequency is displayed first. - DK ON Frequency displayed. The DISP key is invalid. |
| 1 | 0 | Frequency CD | - Tape DK standby - Radio monitor Normally the frequency is displayed. The display is switched to 5 seconds clock display by pressing the DISP key. When the DISP key or the melody selection key is pressed during 5 seconds clock display, the display returns to frequency display. - CD DK standby - Radio Monitor Normally "[CD]" is displayed. When the DISP key is pressed, the display switches to 5 seconds frequency display. When the DISP key is pressed during frequency display, the display switches to 5 seconds clock display. When the DISP key is pressed during clock display, the display returns to "[CD]" display When the melody selection key is pressed during "[CD]" and clock display, the display switches to 5 seconds frequency display. - DK ON Frequency display The DISP key is invalid. | |

| Symbol | Function | | | | | | | | | | | | | |
|---|--|-----------------|-------------------------------|--|------|---------------------|-------|--|------|---|----|----|--|-----------|
| PRIO 1 PRIO 2 | PRIO 1 0 | PRIO 2 1 | Priority Display Clock | Description - Tape DK standby - Radio monitor Normally the clock is displayed. When the <input type="checkbox"/> DISP key or melody selection key is pressed, the display switches to 5 seconds frequency display. When the <input type="checkbox"/> DISP key is pressed during 5 seconds frequency display the display returns to clock display. - CD DK standby - Radio monitor Normally the clock is displayed. When the <input type="checkbox"/> DISP key is pressed, the display switches 5 seconds "CD" display. When the <input type="checkbox"/> DISP key is pressed during this "CD" display, the display switches to 5 seconds frequency display. When the <input type="checkbox"/> DISP key is pressed during frequency display, the display returns to clock display. When the melody selection key is pressed during clock display or "CD" display, the display switches to 5 seconds frequency display. - DK ON Frequency display. The <input type="checkbox"/> DISP key is invalid. | | | | | | | | | | |
| | 1 | 1 | — | Do not set to this mode. | | | | | | | | | | |
| At no clock (NOCLK = 1), the following is displayed and the <input type="checkbox"/> DISP key becomes invalid without regard to the setting of the PRIO1 and PRIO2 switches. And the <input type="checkbox"/> DISP key is invalid. | | | | | | | | | | | | | | |
| <table border="1" style="width: 100%; border-collapse: collapse;"> <thead> <tr> <th style="width: 50%;">Mode</th> <th style="width: 50%;">Display</th> </tr> </thead> <tbody> <tr> <td>Radio</td> <td>Frequency</td> </tr> <tr> <td>Tape</td> <td>None</td> </tr> <tr> <td>CD</td> <td style="text-align: center;">CD</td> </tr> <tr> <td>Tape DK standby CD DK standby DK ON Radio monitor</td> <td style="text-align: center;">Frequency</td> </tr> </tbody> </table> | | | | | Mode | Display | Radio | Frequency | Tape | None | CD | CD | Tape DK standby CD DK standby DK ON Radio monitor | Frequency |
| Mode | Display | | | | | | | | | | | | | |
| Radio | Frequency | | | | | | | | | | | | | |
| Tape | None | | | | | | | | | | | | | |
| CD | CD | | | | | | | | | | | | | |
| Tape DK standby CD DK standby DK ON Radio monitor | Frequency | | | | | | | | | | | | | |
| RDON | Radio ON/OFF method setting switch. Its setting is shown below. <table border="1" style="margin: 10px auto; border-collapse: collapse;"> <thead> <tr> <th style="width: 15%;">RDON</th> <th style="width: 85%;">Radio ON/OFF Method</th> </tr> </thead> <tbody> <tr> <td style="text-align: center;">0</td> <td>Radio is turned on and off by RDSET switch</td> </tr> <tr> <td style="text-align: center;">1.</td> <td>Radio is turned on by making the CE pin High.</td> </tr> </tbody> </table> When this switch was set to 1, do not use the RDSET switch. | | | | RDON | Radio ON/OFF Method | 0 | Radio is turned on and off by RDSET switch | 1. | Radio is turned on by making the CE pin High. | | | | |
| RDON | Radio ON/OFF Method | | | | | | | | | | | | | |
| 0 | Radio is turned on and off by RDSET switch | | | | | | | | | | | | | |
| 1. | Radio is turned on by making the CE pin High. | | | | | | | | | | | | | |



| Symbol | Function | | | | | | |
|---------|---|---------|---------------------|---|---|---|--|
| NOCLK | <p>Clock specified setting switch. Its setting is shown below.</p> <table border="1"> <thead> <tr> <th>NOCLK</th> <th>Clock</th> </tr> </thead> <tbody> <tr> <td>0</td> <td>Yes</td> </tr> <tr> <td>1</td> <td>No</td> </tr> </tbody> </table> <p>In the no clock mode, low consumption current (400nA A max) backup is possible by making the CE pin Low.</p> | NOCLK | Clock | 0 | Yes | 1 | No |
| NOCLK | Clock | | | | | | |
| 0 | Yes | | | | | | |
| 1 | No | | | | | | |
| CLKDISP | <p>Clock time system setting switch. Its setting is shown below.</p> <table border="1"> <thead> <tr> <th>CLKDISP</th> <th>Time System</th> </tr> </thead> <tbody> <tr> <td>0</td> <td> 12-hour clock AM 11:59 → PM 12:00 AM 12:00 ← PM 11:59 </td> </tr> <tr> <td>1</td> <td> 24-hour clock 23:59 → 0:00 </td> </tr> </tbody> </table> | CLKDISP | Time System | 0 | 12-hour clock AM 11:59 → PM 12:00 AM 12:00 ← PM 11:59 | 1 | 24-hour clock 23:59 → 0:00 |
| CLKDISP | Time System | | | | | | |
| 0 | 12-hour clock AM 11:59 → PM 12:00 AM 12:00 ← PM 11:59 | | | | | | |
| 1 | 24-hour clock 23:59 → 0:00 | | | | | | |
| FLASH | <p>Clock colon(:) display setting switch. Its setting is shown below.</p> <table border="1"> <thead> <tr> <th>FLASH</th> <th>Colon (:) Display</th> </tr> </thead> <tbody> <tr> <td>0</td> <td>Steady light</td> </tr> <tr> <td>1</td> <td> Flashing Frequency : 1Hz Duty → 6 (ON) : 4 (OFF) </td> </tr> </tbody> </table> | FLASH | Colon (:) Display | 0 | Steady light | 1 | Flashing Frequency : 1Hz Duty → 6 (ON) : 4 (OFF) |
| FLASH | Colon (:) Display | | | | | | |
| 0 | Steady light | | | | | | |
| 1 | Flashing Frequency : 1Hz Duty → 6 (ON) : 4 (OFF) | | | | | | |

| Symbol | Function | | | | | | | | | | | | | | | | | | | | | | | | | | | | | | | | | | | | | | | | | | | | | | | | | | | | | | | | | | | | | | | | | | | | | | | | | | | | | |
|--|--|-------|-------------------|-------------------|-------------------|-----------------|--|---|---|------------------|-------------------|---|---|---|------------|--|-------------------|---|---|------|-----|------|-----------------|-----------------|-----------------|-----|---|---|-----|-----|-----|---|---|---|-----|-----|---|---|---|----|-----|-----|---|---|-----|---|-----|---|---|---|---|---|----|-----|---|---|---|---|----|---|---|---|---|---|-----|---|---|---|---|---|---|---|---|--|--|--|--|--|
| ENTPK KAMS KNR KMTL | Switches for using the tape functions (AMS, NR, MTL) in common with the radio function keys. The keys that can be used in common can be selected as shown below. | | | | | | | | | | | | | | | | | | | | | | | | | | | | | | | | | | | | | | | | | | | | | | | | | | | | | | | | | | | | | | | | | | | | | | | | | | | | | |
| | <table border="1" style="width: 100%;"> <thead> <tr> <th data-bbox="390 368 465 393">ENTPK</th> <th colspan="5" data-bbox="807 375 919 399">Description</th> </tr> </thead> <tbody> <tr> <td data-bbox="409 768 424 793" rowspan="9">0</td> <td colspan="5" data-bbox="505 422 1291 524"> The M1 (TP1) , M2 (TP2) and M3 (TP3) keys can be used as the AMS , NR, MTL function keys. The keys that can be selected as shown below. </td> </tr> <tr> <td colspan="3"></td> <td colspan="3" style="text-align: center;">Dual Function Key</td> </tr> <tr> <td style="text-align: center;">KAMS</td> <td style="text-align: center;">KNR</td> <td style="text-align: center;">KMTL</td> <td style="text-align: center;">M1 (TP1)</td> <td style="text-align: center;">M2 (TP2)</td> <td style="text-align: center;">M3 (TP3)</td> </tr> <tr> <td style="text-align: center;">1</td> <td style="text-align: center;">1</td> <td style="text-align: center;">1</td> <td style="text-align: center;">AMS</td> <td style="text-align: center;">NR</td> <td style="text-align: center;">MTL</td> </tr> <tr> <td style="text-align: center;">1</td> <td style="text-align: center;">1</td> <td style="text-align: center;">0</td> <td style="text-align: center;">AMS</td> <td style="text-align: center;">NR</td> <td style="text-align: center;">—</td> </tr> <tr> <td style="text-align: center;">1</td> <td style="text-align: center;">0</td> <td style="text-align: center;">1</td> <td style="text-align: center;">AMS</td> <td style="text-align: center;">MTL</td> <td style="text-align: center;">—</td> </tr> <tr> <td style="text-align: center;">1</td> <td style="text-align: center;">0</td> <td style="text-align: center;">0</td> <td style="text-align: center;">AMS</td> <td style="text-align: center;">—</td> <td style="text-align: center;">—</td> </tr> <tr> <td style="text-align: center;">0</td> <td style="text-align: center;">1</td> <td style="text-align: center;">1</td> <td style="text-align: center;">NR</td> <td style="text-align: center;">MTL</td> <td style="text-align: center;">—</td> </tr> <tr> <td style="text-align: center;">0</td> <td style="text-align: center;">1</td> <td style="text-align: center;">0</td> <td style="text-align: center;">NR</td> <td style="text-align: center;">—</td> <td style="text-align: center;">—</td> </tr> <tr> <td style="text-align: center;">0</td> <td style="text-align: center;">0</td> <td style="text-align: center;">1</td> <td style="text-align: center;">MTL</td> <td style="text-align: center;">—</td> <td style="text-align: center;">—</td> </tr> <tr> <td style="text-align: center;">0</td> <td style="text-align: center;">0</td> <td style="text-align: center;">0</td> <td style="text-align: center;">—</td> <td style="text-align: center;">—</td> <td style="text-align: center;">—</td> </tr> <tr> <td colspan="6" data-bbox="505 1052 1312 1120"> That is, the functions selected by 1 are left-justified and used at the M1 (TP1) to M3 (TP3) keys. </td> </tr> </tbody> </table> | ENTPK | Description | | | | | 0 | The M1 (TP1) , M2 (TP2) and M3 (TP3) keys can be used as the AMS , NR, MTL function keys. The keys that can be selected as shown below. | | | | | | | | Dual Function Key | | | KAMS | KNR | KMTL | M1 (TP1) | M2 (TP2) | M3 (TP3) | 1 | 1 | 1 | AMS | NR | MTL | 1 | 1 | 0 | AMS | NR | — | 1 | 0 | 1 | AMS | MTL | — | 1 | 0 | 0 | AMS | — | — | 0 | 1 | 1 | NR | MTL | — | 0 | 1 | 0 | NR | — | — | 0 | 0 | 1 | MTL | — | — | 0 | 0 | 0 | — | — | — | That is, the functions selected by 1 are left-justified and used at the M1 (TP1) to M3 (TP3) keys. | | | | |
| ENTPK | Description | | | | | | | | | | | | | | | | | | | | | | | | | | | | | | | | | | | | | | | | | | | | | | | | | | | | | | | | | | | | | | | | | | | | | | | | | | | | | |
| 0 | The M1 (TP1) , M2 (TP2) and M3 (TP3) keys can be used as the AMS , NR, MTL function keys. The keys that can be selected as shown below. | | | | | | | | | | | | | | | | | | | | | | | | | | | | | | | | | | | | | | | | | | | | | | | | | | | | | | | | | | | | | | | | | | | | | | | | | | | | | |
| | | | | Dual Function Key | | | | | | | | | | | | | | | | | | | | | | | | | | | | | | | | | | | | | | | | | | | | | | | | | | | | | | | | | | | | | | | | | | | | | | | | | | |
| | KAMS | KNR | KMTL | M1 (TP1) | M2 (TP2) | M3 (TP3) | | | | | | | | | | | | | | | | | | | | | | | | | | | | | | | | | | | | | | | | | | | | | | | | | | | | | | | | | | | | | | | | | | | | | | | | |
| | 1 | 1 | 1 | AMS | NR | MTL | | | | | | | | | | | | | | | | | | | | | | | | | | | | | | | | | | | | | | | | | | | | | | | | | | | | | | | | | | | | | | | | | | | | | | | | |
| | 1 | 1 | 0 | AMS | NR | — | | | | | | | | | | | | | | | | | | | | | | | | | | | | | | | | | | | | | | | | | | | | | | | | | | | | | | | | | | | | | | | | | | | | | | | | |
| | 1 | 0 | 1 | AMS | MTL | — | | | | | | | | | | | | | | | | | | | | | | | | | | | | | | | | | | | | | | | | | | | | | | | | | | | | | | | | | | | | | | | | | | | | | | | | |
| | 1 | 0 | 0 | AMS | — | — | | | | | | | | | | | | | | | | | | | | | | | | | | | | | | | | | | | | | | | | | | | | | | | | | | | | | | | | | | | | | | | | | | | | | | | | |
| | 0 | 1 | 1 | NR | MTL | — | | | | | | | | | | | | | | | | | | | | | | | | | | | | | | | | | | | | | | | | | | | | | | | | | | | | | | | | | | | | | | | | | | | | | | | | |
| | 0 | 1 | 0 | NR | — | — | | | | | | | | | | | | | | | | | | | | | | | | | | | | | | | | | | | | | | | | | | | | | | | | | | | | | | | | | | | | | | | | | | | | | | | | |
| 0 | 0 | 1 | MTL | — | — | | | | | | | | | | | | | | | | | | | | | | | | | | | | | | | | | | | | | | | | | | | | | | | | | | | | | | | | | | | | | | | | | | | | | | | | | |
| 0 | 0 | 0 | — | — | — | | | | | | | | | | | | | | | | | | | | | | | | | | | | | | | | | | | | | | | | | | | | | | | | | | | | | | | | | | | | | | | | | | | | | | | | | |
| That is, the functions selected by 1 are left-justified and used at the M1 (TP1) to M3 (TP3) keys. | | | | | | | | | | | | | | | | | | | | | | | | | | | | | | | | | | | | | | | | | | | | | | | | | | | | | | | | | | | | | | | | | | | | | | | | | | | | | | |
| 1 | <p>Of the AMS, NR and MTL function keys, two functions can be used at the LOC (TP4) and MONO (TP5) keys. The following can be selected :</p> <table border="1" style="width: 100%;"> <thead> <tr> <th data-bbox="530 1342 601 1367">KAMS</th> <th data-bbox="632 1342 703 1367">KNR</th> <th data-bbox="733 1342 804 1367">KMTL</th> <th colspan="2" data-bbox="904 1311 1094 1336">Dual Function Key</th> </tr> <tr> <td colspan="3"></td> <td style="text-align: center;">LOC (TP4)</td> <td style="text-align: center;">MONO (TP5)</td> </tr> </thead> <tbody> <tr> <td style="text-align: center;">1</td> <td style="text-align: center;">1</td> <td style="text-align: center;">1</td> <td colspan="2" style="text-align: center;">Do not set</td> </tr> <tr> <td style="text-align: center;">1</td> <td style="text-align: center;">1</td> <td style="text-align: center;">0</td> <td style="text-align: center;">AMS</td> <td style="text-align: center;">NR</td> </tr> <tr> <td style="text-align: center;">1</td> <td style="text-align: center;">0</td> <td style="text-align: center;">1</td> <td style="text-align: center;">AMS</td> <td style="text-align: center;">MTL</td> </tr> <tr> <td style="text-align: center;">1</td> <td style="text-align: center;">0</td> <td style="text-align: center;">0</td> <td style="text-align: center;">AMS</td> <td style="text-align: center;">—</td> </tr> <tr> <td style="text-align: center;">0</td> <td style="text-align: center;">1</td> <td style="text-align: center;">1</td> <td style="text-align: center;">NR</td> <td style="text-align: center;">MTL</td> </tr> <tr> <td style="text-align: center;">0</td> <td style="text-align: center;">1</td> <td style="text-align: center;">0</td> <td style="text-align: center;">NR</td> <td style="text-align: center;">—</td> </tr> <tr> <td style="text-align: center;">0</td> <td style="text-align: center;">0</td> <td style="text-align: center;">1</td> <td style="text-align: center;">MTL</td> <td style="text-align: center;">—</td> </tr> <tr> <td style="text-align: center;">0</td> <td style="text-align: center;">0</td> <td style="text-align: center;">0</td> <td style="text-align: center;">—</td> <td style="text-align: center;">—</td> </tr> </tbody> </table> <p>The functions selected by 1 are left-justified and used at the LOC (TP4) and MONO (TP5) keys.</p> | KAMS | KNR | KMTL | Dual Function Key | | | | | LOC (TP4) | MONO (TP5) | 1 | 1 | 1 | Do not set | | 1 | 1 | 0 | AMS | NR | 1 | 0 | 1 | AMS | MTL | 1 | 0 | 0 | AMS | — | 0 | 1 | 1 | NR | MTL | 0 | 1 | 0 | NR | — | 0 | 0 | 1 | MTL | — | 0 | 0 | 0 | — | — | | | | | | | | | | | | | | | | | | | | | | | | | | | |
| KAMS | KNR | KMTL | Dual Function Key | | | | | | | | | | | | | | | | | | | | | | | | | | | | | | | | | | | | | | | | | | | | | | | | | | | | | | | | | | | | | | | | | | | | | | | | | | | |
| | | | LOC (TP4) | MONO (TP5) | | | | | | | | | | | | | | | | | | | | | | | | | | | | | | | | | | | | | | | | | | | | | | | | | | | | | | | | | | | | | | | | | | | | | | | | | | |
| 1 | 1 | 1 | Do not set | | | | | | | | | | | | | | | | | | | | | | | | | | | | | | | | | | | | | | | | | | | | | | | | | | | | | | | | | | | | | | | | | | | | | | | | | | | |
| 1 | 1 | 0 | AMS | NR | | | | | | | | | | | | | | | | | | | | | | | | | | | | | | | | | | | | | | | | | | | | | | | | | | | | | | | | | | | | | | | | | | | | | | | | | | |
| 1 | 0 | 1 | AMS | MTL | | | | | | | | | | | | | | | | | | | | | | | | | | | | | | | | | | | | | | | | | | | | | | | | | | | | | | | | | | | | | | | | | | | | | | | | | | |
| 1 | 0 | 0 | AMS | — | | | | | | | | | | | | | | | | | | | | | | | | | | | | | | | | | | | | | | | | | | | | | | | | | | | | | | | | | | | | | | | | | | | | | | | | | | |
| 0 | 1 | 1 | NR | MTL | | | | | | | | | | | | | | | | | | | | | | | | | | | | | | | | | | | | | | | | | | | | | | | | | | | | | | | | | | | | | | | | | | | | | | | | | | |
| 0 | 1 | 0 | NR | — | | | | | | | | | | | | | | | | | | | | | | | | | | | | | | | | | | | | | | | | | | | | | | | | | | | | | | | | | | | | | | | | | | | | | | | | | | |
| 0 | 0 | 1 | MTL | — | | | | | | | | | | | | | | | | | | | | | | | | | | | | | | | | | | | | | | | | | | | | | | | | | | | | | | | | | | | | | | | | | | | | | | | | | | |
| 0 | 0 | 0 | — | — | | | | | | | | | | | | | | | | | | | | | | | | | | | | | | | | | | | | | | | | | | | | | | | | | | | | | | | | | | | | | | | | | | | | | | | | | | |

| Symbol | Function | | | | | | | | |
|--|--|------|------|--|-------------|----------|----------|-----------|------------|
| | The operation of each key is the same as that of the momentary keys AMS , NR and MTL . Summarizing the above, the five keys M1 (TP1) to M3 (TP3) , LOC (TP4) and scan be used as MONO (TP5) tape function keys. Which functions used in common are determined by the ENTPK, KAMS, KNR and KMTL switches. This summarized below. | | | | | | | | |
| | ENTPK | KAMS | KNR | KMTL | M1 (TP1) | M2 (TP2) | M3 (TP3) | LOC (TP4) | MONO (TP5) |
| ENTPK KAMS KNR KMTL | 0 | 1 | 1 | 1 | AMS | NR | MTL | | |
| | | 1 | 1 | 0 | AMS | NR | | | |
| | | 1 | 0 | 1 | AMS | MTL | | | |
| | | 1 | 0 | 0 | AMS | | | | |
| | | 0 | 1 | 1 | NR | MTL | | | |
| | | 0 | 1 | 0 | NR | | | | |
| | | 0 | 0 | 1 | MTL | | | | |
| | | 0 | 0 | 0 | | | | | |
| | 1 | 1 | 1 | 1 | Do not set. | | | | |
| | | 1 | 1 | 0 | | | | AMS | NR |
| | | 1 | 0 | 1 | | | | AMS | MTL |
| | | 1 | 0 | 0 | | | | AMS | |
| | | 0 | 1 | 1 | | | | NR | MTL |
| | | 0 | 0 | 0 | | | | NR | |
| | | | | | | | MTL | | |
| When these functions are used, tuning operations in the tape DK standby, CD DK standby and radio monitor and DK ON modes are restricted as follows : | | | | | | | | | |
| ENTPK | KAMS | KNR | KMTL | | | | | | |
| 0 | 0 | 0 | 0 | Normal tuning possible. | | | | | |
| 0 | When even switch is 1 | | | Tuning by M1 (TP1) to M6 key is impossible | | | | | |
| 1 | — | — | — | The LOC (TP4) and MONO (TP5) keys cannot be used as local and monaural keys. | | | | | |

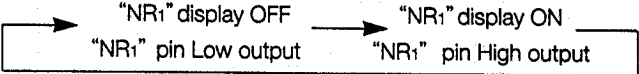
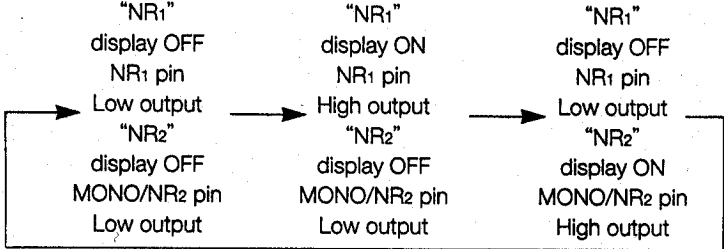
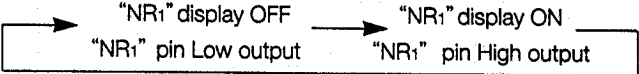
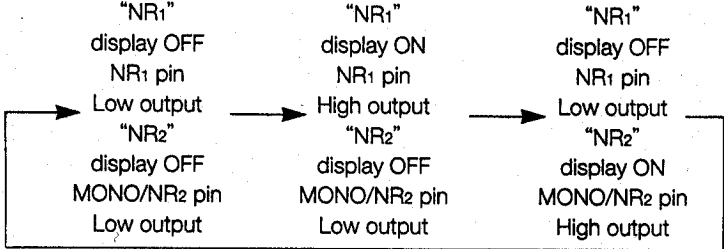
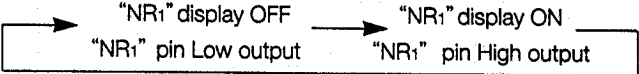
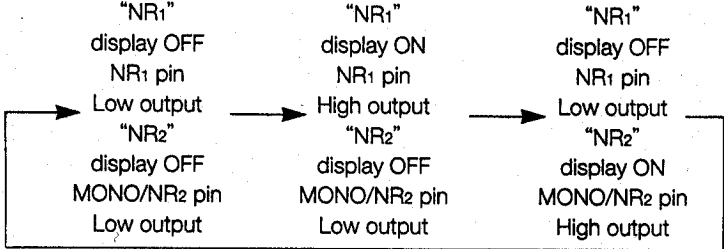
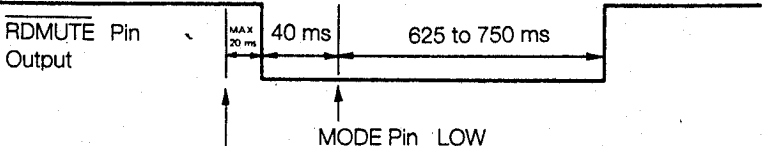
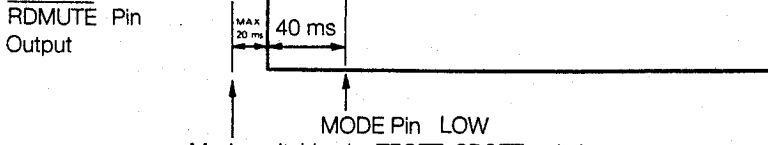
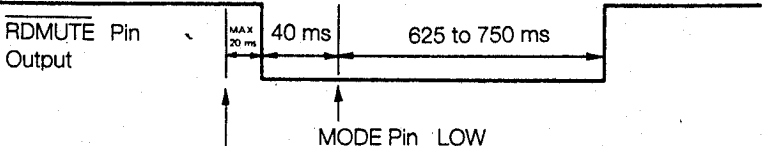
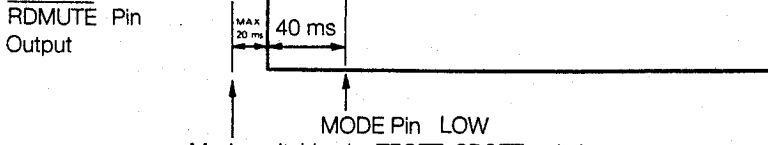
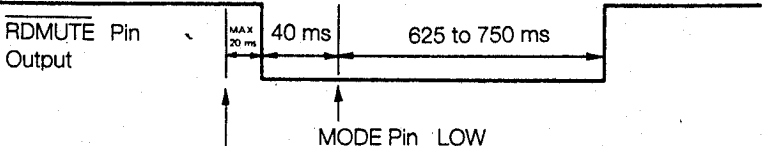
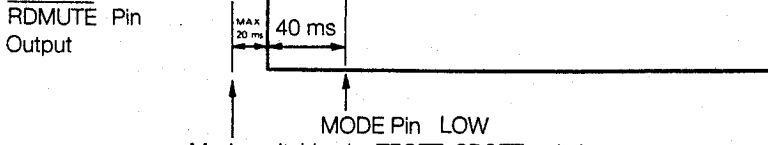

| Symbol | Function | | | | | | |
|---------|---|-------------------|-------------------|---|---|---|--|
| ENNR2 | <p>Switch that enables the NR₂ (Noise Reduction) function in the tape mode. Its setting is shown below.</p> <table border="1" data-bbox="333 368 1347 1094"> <thead> <tr> <th data-bbox="333 368 476 416">ENNR2</th> <th data-bbox="480 368 1347 416">Description</th> </tr> </thead> <tbody> <tr> <td data-bbox="333 422 476 650">0</td> <td data-bbox="480 422 1347 650"> <p>NR₂ function cannot be used. When the <input type="checkbox"/> NR key or NR function key (selected by KNR switch) is pressed, the LCD panel "NR₁" display and NR₁ pin output changes as follows :</p> <div style="text-align: center;">  </div> </td> </tr> <tr> <td data-bbox="333 656 476 1094">1</td> <td data-bbox="480 656 1347 1094"> <p>Both the NR₁ and NR₂ functions can be used. When the <input type="checkbox"/> NR key or NR function key (selected by KNR switch) is pressed, the LCD panel "NR₁" and "NR₂" displays and NR₁ and MONO/NR₂ pins output change as follows :</p> <div style="text-align: center;">  </div> </td> </tr> </tbody> </table> | ENNR2 | Description | 0 | <p>NR₂ function cannot be used. When the <input type="checkbox"/> NR key or NR function key (selected by KNR switch) is pressed, the LCD panel "NR₁" display and NR₁ pin output changes as follows :</p> <div style="text-align: center;">  </div> | 1 | <p>Both the NR₁ and NR₂ functions can be used. When the <input type="checkbox"/> NR key or NR function key (selected by KNR switch) is pressed, the LCD panel "NR₁" and "NR₂" displays and NR₁ and MONO/NR₂ pins output change as follows :</p> <div style="text-align: center;">  </div> |
| | ENNR2 | Description | | | | | |
| 0 | <p>NR₂ function cannot be used. When the <input type="checkbox"/> NR key or NR function key (selected by KNR switch) is pressed, the LCD panel "NR₁" display and NR₁ pin output changes as follows :</p> <div style="text-align: center;">  </div> | | | | | | |
| 1 | <p>Both the NR₁ and NR₂ functions can be used. When the <input type="checkbox"/> NR key or NR function key (selected by KNR switch) is pressed, the LCD panel "NR₁" and "NR₂" displays and NR₁ and MONO/NR₂ pins output change as follows :</p> <div style="text-align: center;">  </div> | | | | | | |
| MUTESEL | <p>Sets the RDMUTE pin output method in the tape and CD modes. Its setting is shown below.</p> <table border="1" data-bbox="333 1203 1347 1829"> <thead> <tr> <th data-bbox="333 1203 476 1251">MUTESEL</th> <th data-bbox="480 1203 1347 1251">RDMUTE Pin Output</th> </tr> </thead> <tbody> <tr> <td data-bbox="333 1257 476 1556">1</td> <td data-bbox="480 1257 1347 1556"> <p>In the tape and CD modes, muting is turned off.</p> <div style="text-align: center;">  </div> <p>When MUTESEL = 1 is set, do not use the DK standby and radio monitor functions.</p> </td> </tr> <tr> <td data-bbox="333 1562 476 1829">0</td> <td data-bbox="480 1562 1347 1829"> <p>In the tape and CD modes, muting remains ON.</p> <div style="text-align: center;">  </div> </td> </tr> </tbody> </table> <p>For details, see "Radio.Mute Output Timing"</p> | MUTESEL | RDMUTE Pin Output | 1 | <p>In the tape and CD modes, muting is turned off.</p> <div style="text-align: center;">  </div> <p>When MUTESEL = 1 is set, do not use the DK standby and radio monitor functions.</p> | 0 | <p>In the tape and CD modes, muting remains ON.</p> <div style="text-align: center;">  </div> |
| | MUTESEL | RDMUTE Pin Output | | | | | |
| 1 | <p>In the tape and CD modes, muting is turned off.</p> <div style="text-align: center;">  </div> <p>When MUTESEL = 1 is set, do not use the DK standby and radio monitor functions.</p> | | | | | | |
| 0 | <p>In the tape and CD modes, muting remains ON.</p> <div style="text-align: center;">  </div> | | | | | | |

| Symbol | Function | | | |
|-------------------|---|---|--------|------------------------------------|
| ENFMIF DISAMIF | IF counter use setting switch. Its setting is shown below. | | | |
| | ENFMIF | DISAMIF | BAND | Broadcast Station Detection Method |
| | 1 | 0 | FM | IF counter and SD system |
| | | | MW, LW | IF counter and SD system |
| | 1 | 1 | FM | IF counter and SD system |
| | | | MW, LW | SD system |
| | 0 | 0 | FM | SD system |
| | | | MW, LW | IF counter and SD system |
| | 0 | 1 | FM | SD system |
| | | | MW, LW | SD system |
| DISAMEMO | DISAMEMO | Description | | |
| | 0 | Enables the auto preset memory function. When the  key is pressed for more than 2 seconds, auto preset memory operation begins. | | |
| | | Disables the auto preset memory function The  key performs the preset scan function only. | | |

3. MODE TRANSITION

With the DMC 4002, the radio can be turned on and off by the following two methods:

- (1) By CE pin when the initialized diode switch RDON = 1
- (2) By turning the transistor or alternate switch RDSET on and off

The mode transition at each operation is described in 3.1, 3.2 and 3.3.

3.1 WHEN THE INITIALIZED DIODE RDON = 1 (RADIO ON/OFF BY CE PIN)

The radio mode is turned on and off by CE pin.

Switching to the tape and CD modes is performed by TPSET and CDSET switches, respectively.

When RDON = 1, do not use the RDSET switch.

When the CE pin is made Low level, clock display is not performed.

- (1) CE : Low to High

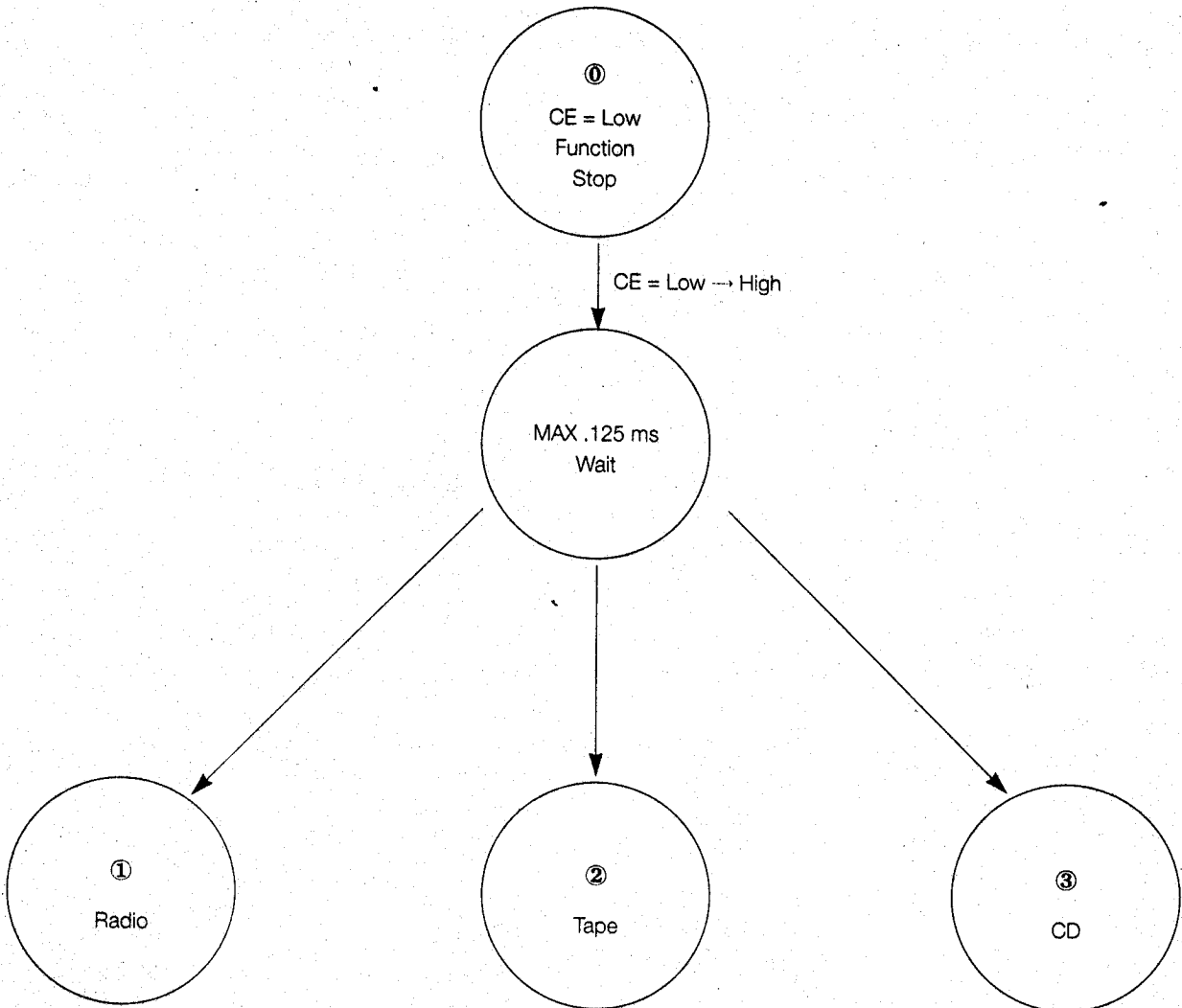

(2) CE : High Level

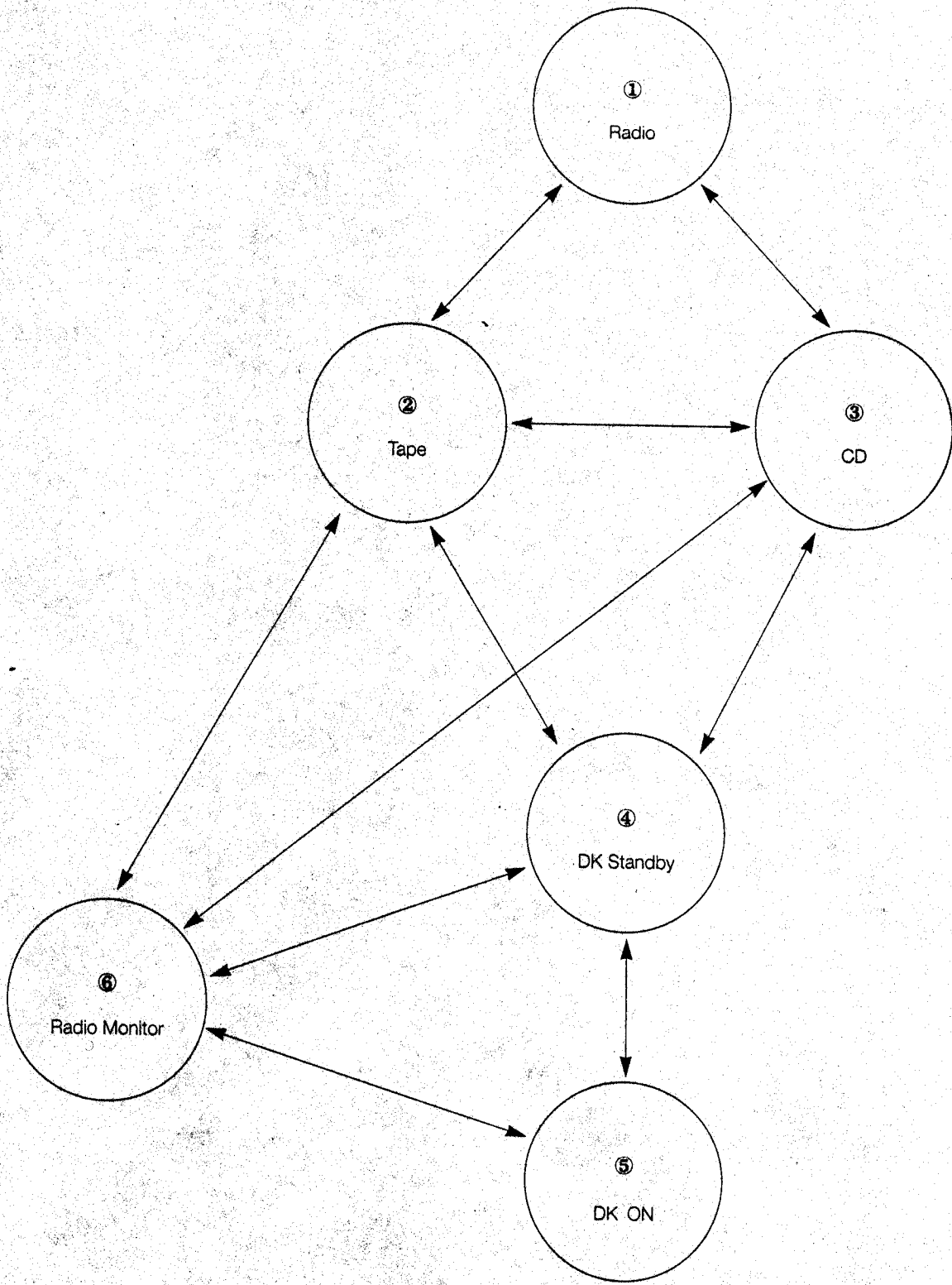

3.2 RADIO ON/OFF BY RDSET SWITCH

The radio mode is turned on and off by RDSET switch.

Switching to the tape and CD mode is performed by TPSET and CDSET switch, respectively.

The difference from RDON=1 of 3.1 is that the clock is displayed even when the radio, tape and CD modes are OFF.

(1) CE : Low to high

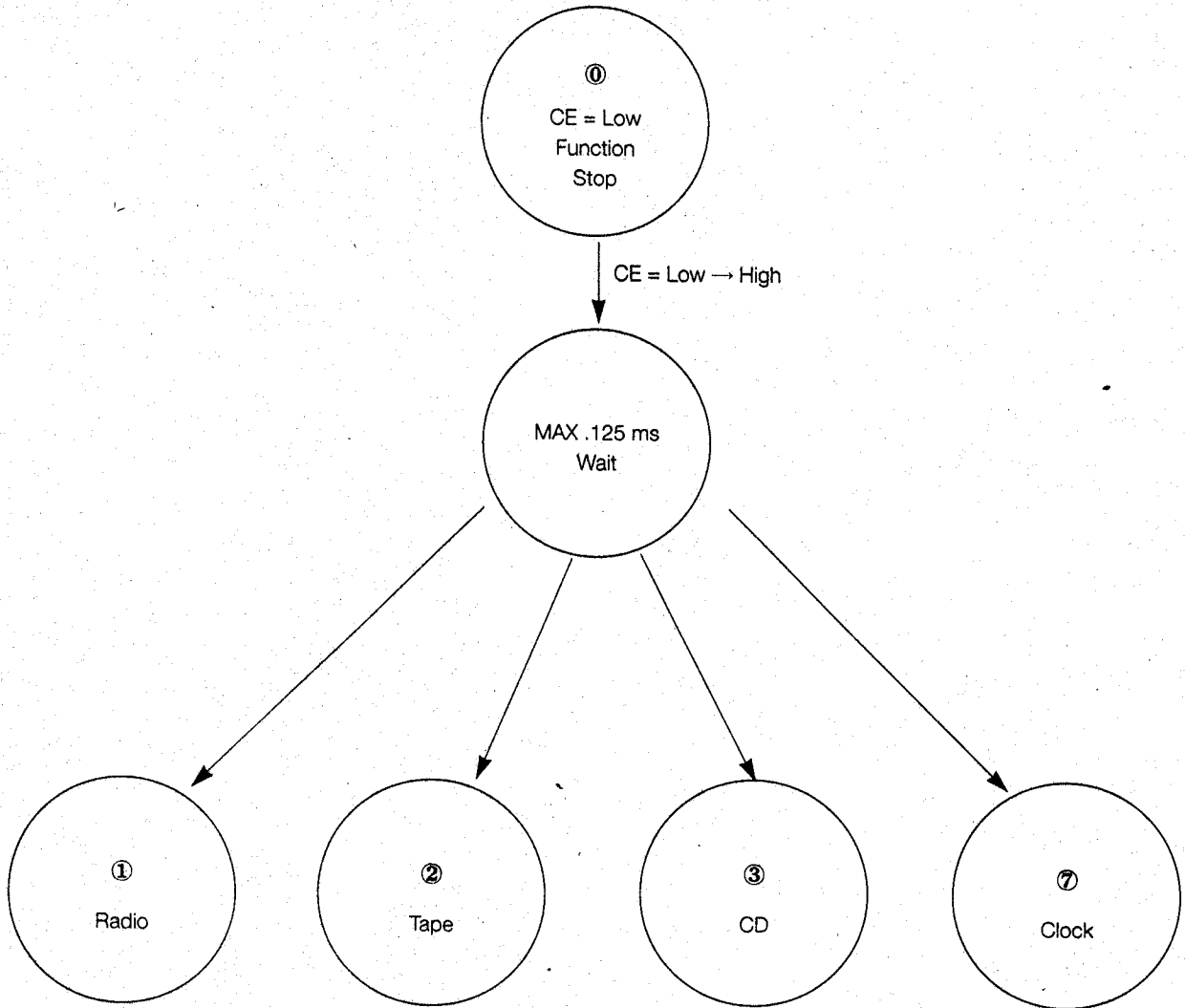

(2) CE : High Level

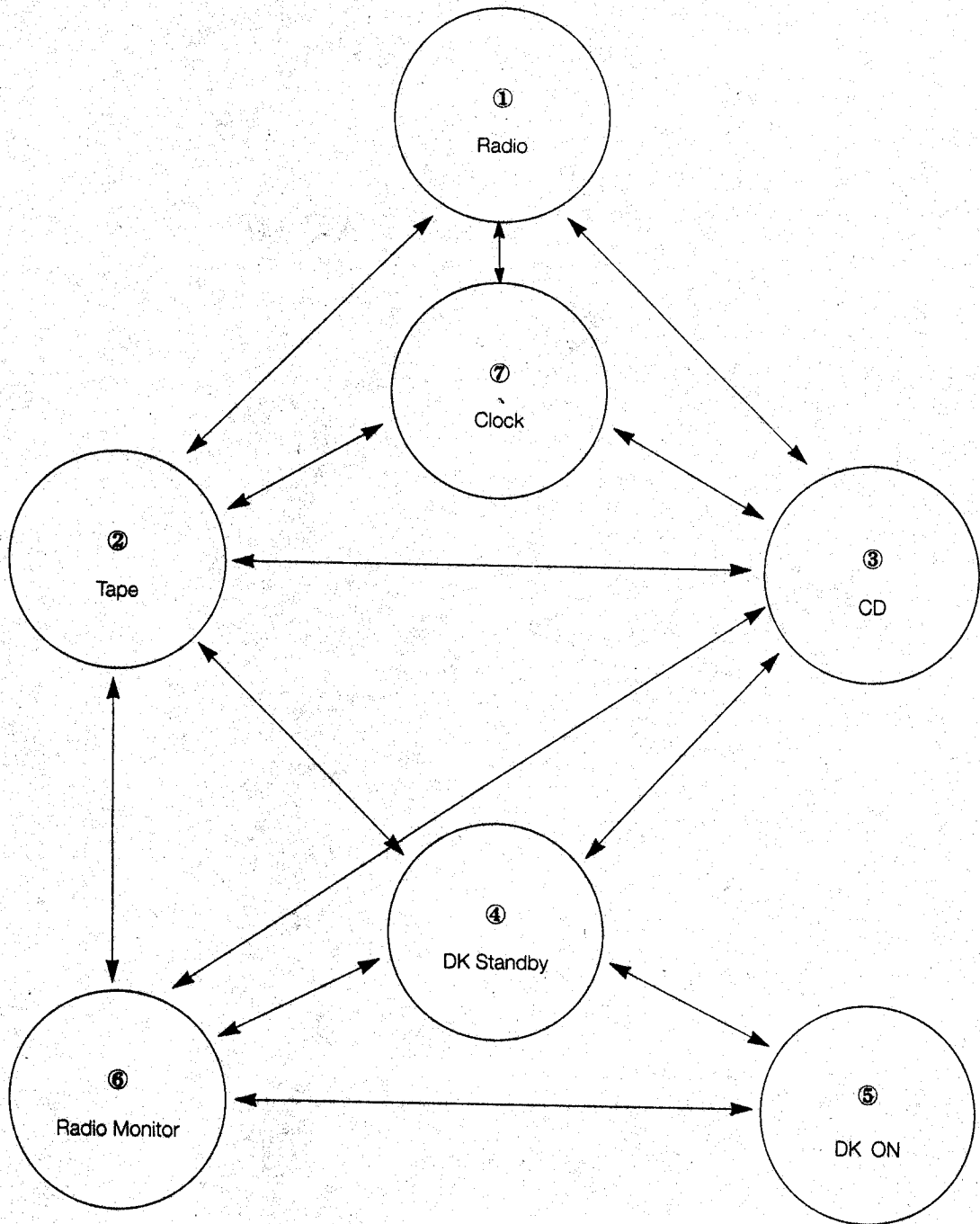

3.3 DESCRIPTION OF EACH MODE

| Mode | Description |
|--------------------|--|
| ① CE = Low | Backup mode. When the NOCLK switch is set to no clock, low consumption current(400nA Max.) backup is possible. When clock is selected, the device is set to the clock count mode. In the mode, the maximum consumption current is 500 μ A. |
| ① Radio | When the CE pin is high level and the TPSET and CDSET switches are OFF, the device is set to the radio mode. |
| ② Tape | When the CE pin is high level and the TPSET switch is ON and the CDSET switch is OFF, the device is set to the tape mode. |
| ③ CD | When the CE pin is high level and the CDSET switch is ON, the device is set to the CD mode. |
| ④ DK Standby | When the VF band is received in the radio mode and the mode is switched to the tape or CD mode by TPSET or CDSET switch, the device is set to the DK standby mode. The device is also set to the DK standby mode by pressing the <input type="checkbox"/> VF key in the tape or CD modes. In the DK standby mode, VF band tuning operation is enabled. |
| ⑤ D · K | When the DK switch is set to ON in the DK standby mode, the device enters the DK ON mode. In the DK ON mode, radio muting ($\overline{\text{RDMUTE}}$ pin) is turned off and audio muting ($\overline{\text{AMUTE}}$ pin) is turned on. |
| ⑥ Radio monitor | When the tape mode is set by TPSET switch when the radio monitor mode is ON by <input type="checkbox"/> RDMONI in the radio mode, the device enters the radio monitor mode. The radio monitor mode is also set by pressing the <input type="checkbox"/> RDMONI key in the tape and CD modes. In the radio monitor mode, normal tuning operation is possible. In the radio monitor mode, radio muting ($\overline{\text{RDMUTE}}$ pin) is turned off and audio muting ($\overline{\text{AMUTE}}$ pin) is turned on. |
| ⑦ Clock | NOCLK = 0 Only clock display is performed. Clock adjustment is also possible. NOCLK = 1 Function is disabled. However, since the CE is high level, the consumption current is 500 μ A Typ. |



3.4 RADIO ON/OFF BY POWER KEY

The **POWER** key valid when CE pin is high level.

Each time the key is pressed, the POWER pin (pin 23) output is inverted.

Therefore, a circuit is configured so that the radio is turned on and off by setting RDON = 0 and turning the RDSET switch on and off by POWER pin.

For details, see "Application Circuits".



4. DISPLAY

4.1 LCD PANEL

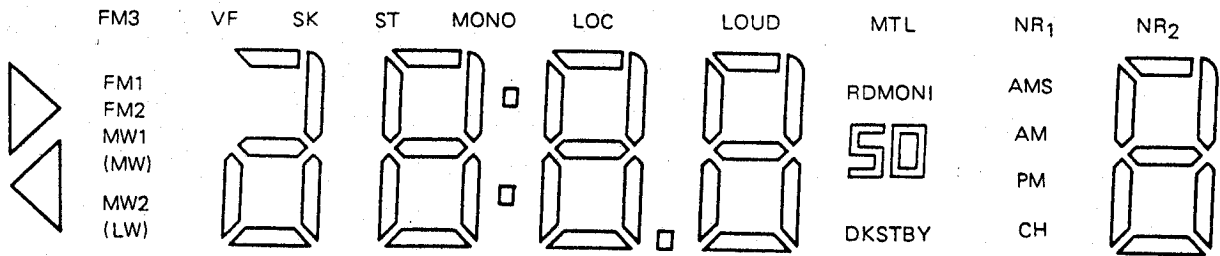

4.2 DISPLAY TYPE

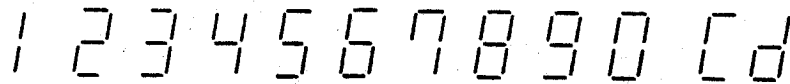

4.3 SEGMENT LINES

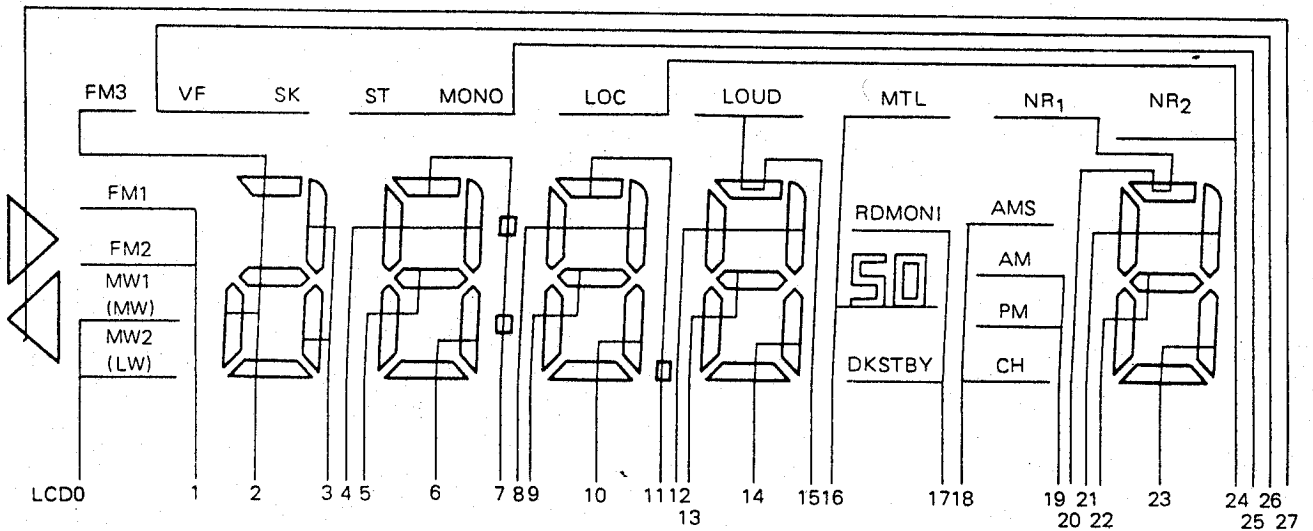

4.4 COMMON LINES

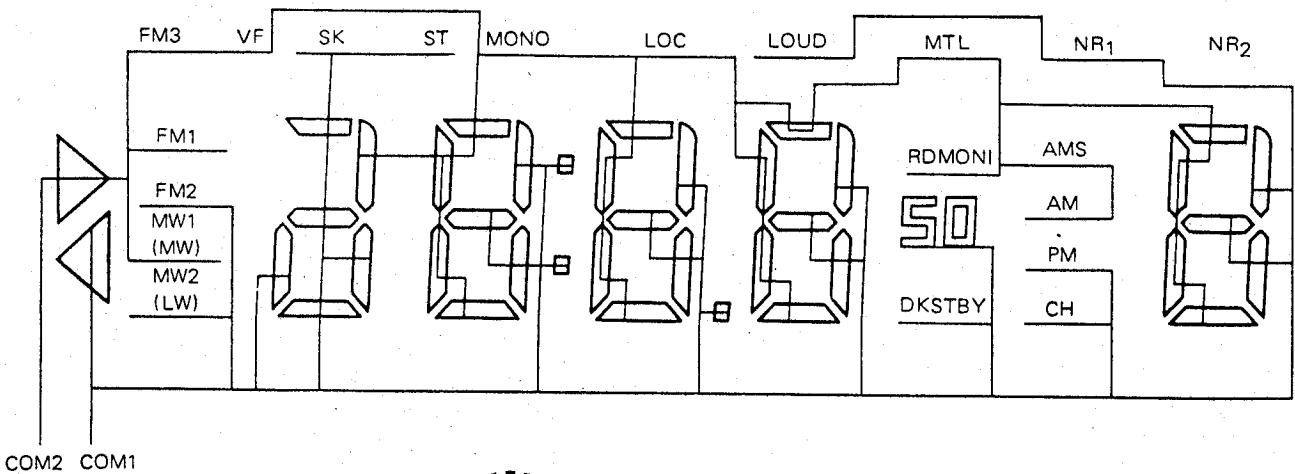

4.5 LCD ASSIGNMENT TABLE

| LCD | COM1 | COM2 |
|-----|----------------|---------|
| 0 | MW2(LW) | MW1(MW) |
| 1 | FM2 | FM1 |
| 2 | 4a, 4d, 4e, 4g | FM3 |
| 3 | 4c | 4b |
| 4 | 3b | 3f |
| 5 | 3g | 3e |
| 6 | 3c | 3d |
| 7 | COLON(:) | 3a |
| 8 | 2b | 2f |
| 9 | 2g | 2e |
| 10 | 2c | 2d |
| 11 | POINT(.) | 2a |
| 12 | 1b | 1f |
| 13 | 1g | 1e |
| 14 | 1c | 1d |
| 15 | LOUD | 1a |
| 16 | 50 | MTL |
| 17 | DKSTBY | RDMONI |
| 18 | CH | AMS |
| 19 | PM | AM |
| 20 | NR1 | Ca |
| 21 | Cb | Cf |
| 22 | Cg | Ce |
| 23 | Cc | Cd |
| 24 | NR2 | LOC |
| 25 | ST | MONO |
| 26 | SK | VF |
| 27 | ◁ | ▷ |

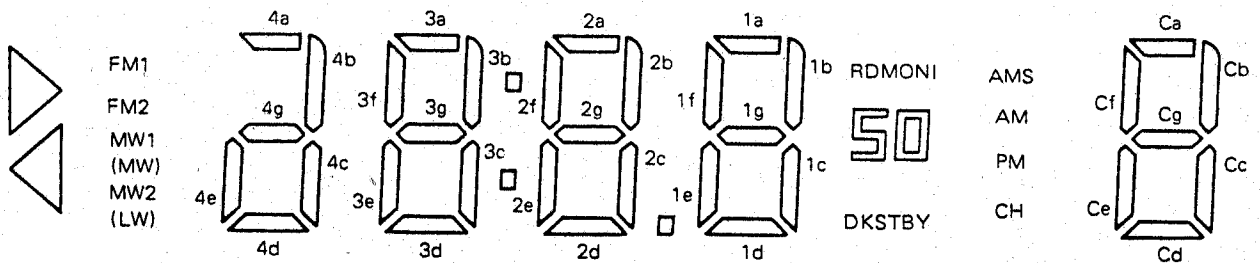

FM3 VF SK ST MONO LOC LOUD MTL NR1 NR2



4.6 DESCRIPTION OF DISPLAYS

| Display | Description |
|-----------------|---|
| VF | Indicates that the device is on the VF band. |
| SK | Indicates that the SK signal is input. It lights when the SK switch is turned on at the FM and VF bands. |
| ST | Indicates that a STEREO signal is input. It lights when the \overline{ST} pin (pin 64) becomes Low on the FM and VF bands. However, it does not light in the MONO mode. |
| MONO | Indicates that the device is in the monaural mode. When the <input type="checkbox"/> MONO key is pressed on the FM and VF bands, the display is inverted. High level is output from the MONO/NR ₂ pin(pin 18) while this display is lit. It is invalid on the MW and LW bands. |
| LOC | Indicates the LOCAL status. This display is reversed when <input type="checkbox"/> LOC key is pressed in radio mode(FM, MW, LW bands). When the display flashes, High level is output from LOC pin(No. 10 pin). |
| LOUD | Indicates that the device is in the LOUDNESS state. When the <input type="checkbox"/> LOUD key is pressed in the radio, tape or CD mode, this display is inverted. High level is output from the LOUD pin (pin 19) while this display is lit. |
| MTL | Indicates that the device is in the METAL state. When the <input type="checkbox"/> METAL function key is pressed in the tape mode, this display is inverted. High level is output from the MTL pin (pin 21) while this display is lit. |
| NR ₁ | Indicates that the device is in the NR ₁ (Noise Reduction) state. When the device is placed into the NR ₁ state by <input type="checkbox"/> NR function key in the tape mode, this display lights. High level is output from the NR ₁ pin (pin 22) while this display is lit. |
| NR ₂ | Indicates that the device is in the NR ₂ (Noise Reduction) state. The NR ₂ function can be used with the initialized diode ENNR ₂ switch. When the device was placed into the NR ₂ state by <input type="checkbox"/> NR function key in the tape mode, this display lights. High level is output from the MONO / NR ₂ pin (pin 18) while this display is lit. |
| DKSTBY | Lights in the DK standby and DK ON modes in the tape/CD mode. |
| ◁ ▷ | Indicates the direction of tape travel. In the tape mode, this display indicates the tape direction according to the state of the RL switch. If the FF switch is ON, this display flashes. For more information, see the description of each pin. |

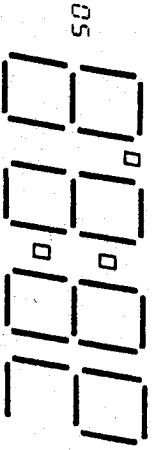

| Display | Description |
|---|---|
| FM1 FM2 FM3 MW1(MW) MW2(LW) | Indicates the receiving band in the radio mode. In Europe, when the device is switched to LW band, "MW2 (LW)" lights. |
|  <p>The diagrams show the display in three states: 1. Receiving frequency display with '50.' and 'CD' indicators. 2. CD display with 'CD' indicator. 3. Clock display showing '12:00' and '24:00'.</p> | Displays the receiving frequency, CD and clock. - Receiving frequency display Displayed in the radio mode. "50" is displayed only on the Europe and South Africa FM bands. "." (D.P) is displayed as the decimal point on the FM bands. - CD display When the device enters the CD mode, the following is displayed. - Clock display  12 hour clock or 24 hour clock can be selected by the initialized diode CLKDSP switch. Flashing of the ":" (colon) display is possible by the initialized diode FLASH switch. |
| AMS | Indicates that the device is in the AMS (Auto Music Search) state. When the <input type="button" value="AMS"/> function key is pressed in the tape mode, this display is inverted. High level is output from the AMS pin (pin 20) while this display is lit. |
| AM PM | 12 hour clock AM and PM display. |
|  <p>The diagram shows the 'ch' display with the label 'ch' to its left.</p> | Indicates the preset memory number and AMS selection number. - Preset memory number display. In the radio mode, when preset memory write and call are performed, the corresponding preset number and "ch" are displayed. In the memory write mode set by <input type="button" value="ME"/> key, the "ch" display flashes at 1HZ. During preset memory scanning by <input type="button" value="PSCAN"/> key, the preset memory number display (Ca to Cg) flashes at 1 Hz. |
| RDMONI | Lights in the radio monitor mode. |

5. RADIO MUTE OUTPUT TIMING (RDMUTE)

- ① Key ON chattering prevention
- ② Premuting and BEEP output
- ③ Division ratio setting and display contents updating
- ④ Postmuting
- ⑤ Scan time
- ⑥ PLL lock wait time

5.1 RADIO MUTE (RDMUTE PIN) OUTPUT TIMING CHARTS

1) Manual up/down

(1) 1 channel up/down

(a) AUTO 500 switch = 0

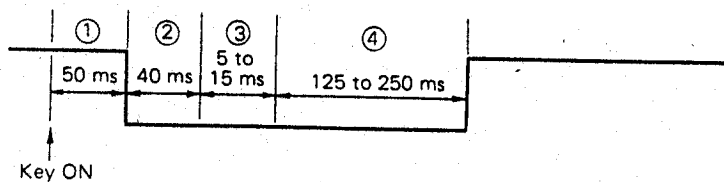

(b) AUTO 500 switch = 1

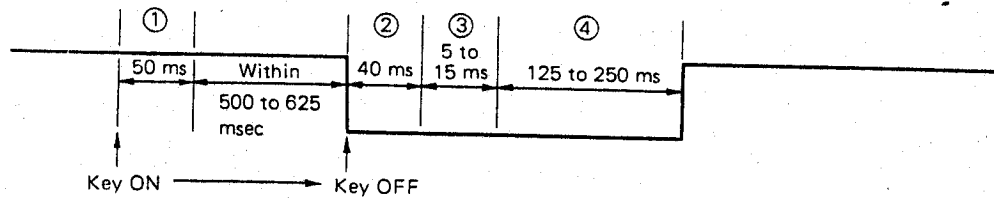

At the band edge (between lowest frequency and highest frequency) of both (a) and (b), time ④ is 625 to 750 ms.

(2) Continuous up/down

(a) AUTO 500 switch = 0

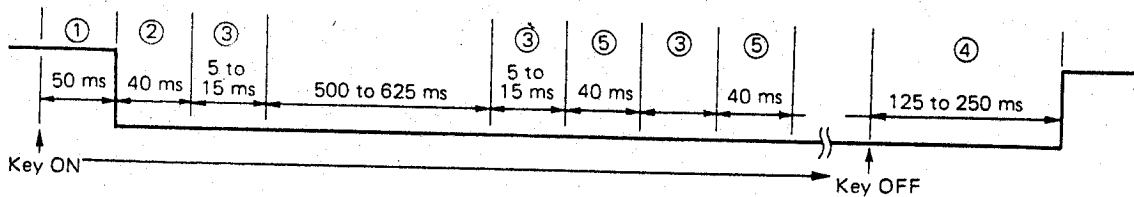

At the band edge, time ⑤ becomes 540 to 665 ms and time ④ becomes 625 to 750 ms.

(b) When AUTO 500 switch = 1, continuous up/down is not performed because holding down the key for more than 0.5 seconds sets autotuning.

2) Auto up / down

(1) **SEEK UP**, **SEEK DWN**, **SCAN UP**, **SEEK DWN** keys

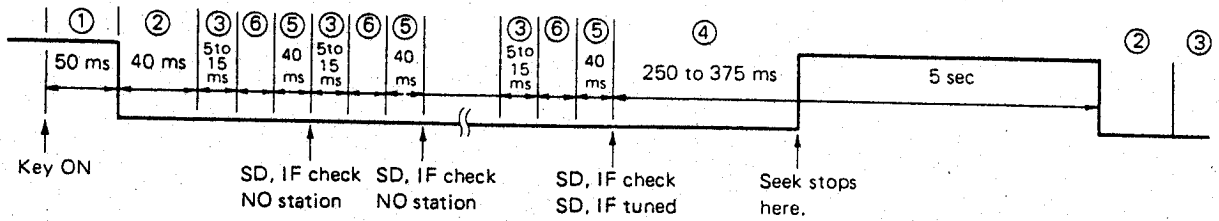

(2) **MAN UP**, **MAN DWN** key held down for more than 0.5 seconds when AUTO 500 switch = 1

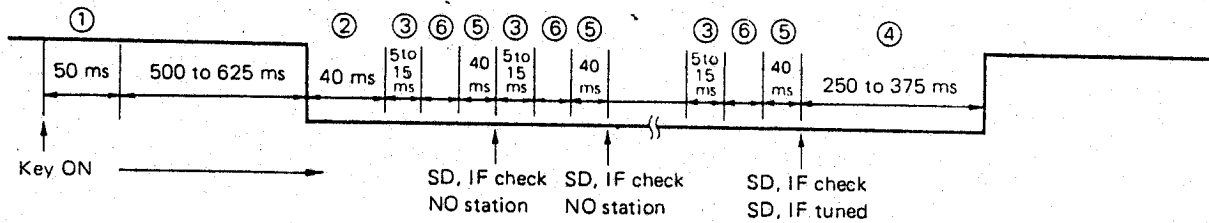

At both (1) and (2), at the band edge time ⑤ becomes 520 to 695 ms.

IF check is performed twice, once in the FAST mode and once in the SLOW mode.

FAST mode IF check takes approx. 6 ms on the FM, MW and LW bands and SLOW mode IF check takes approx. 15 ms on the FM band and approx. 25 ms on the MW and LW bands

3) Preset memory call

(1) M2S switch = 0

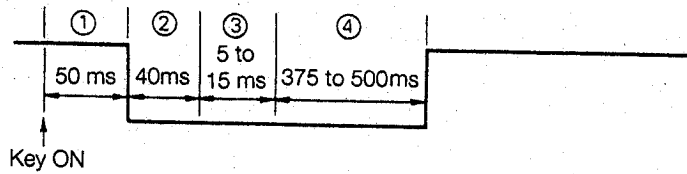

(2) M2S switch = 1

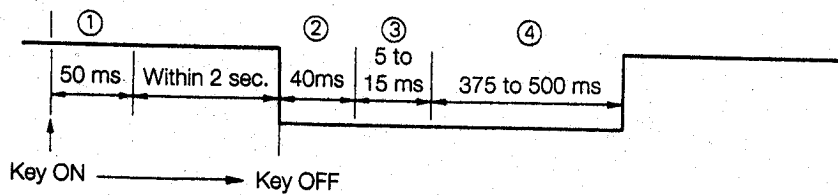

4) Preset memory write

(1) M2S switch = 0

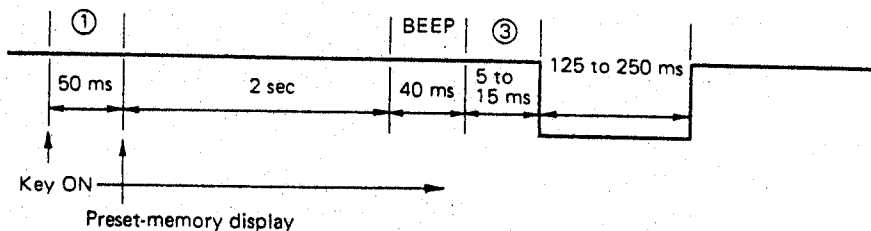

(2) When M2S switch = 1, muting is not output.

5) Preset memory scan

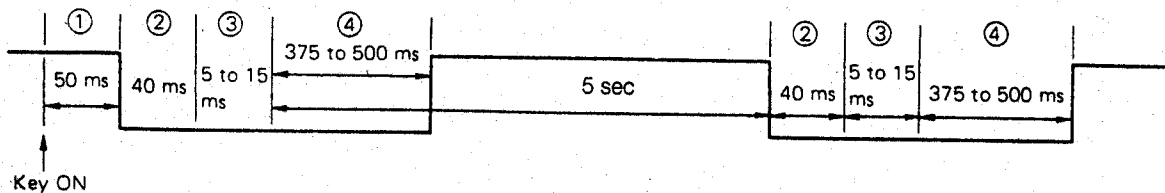

6) VF mode

(1) When VF mode selected with VF key ON

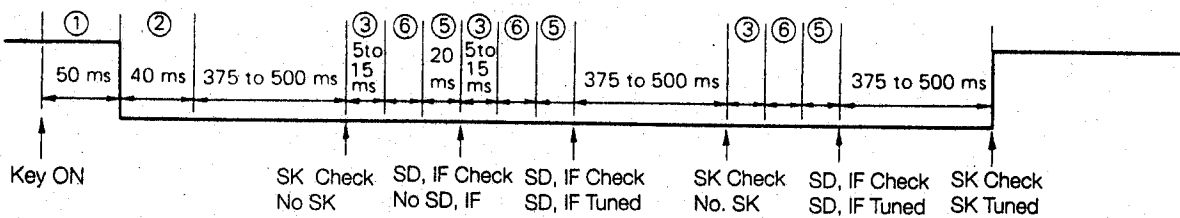

(2) Seek and scan operating in VF mode

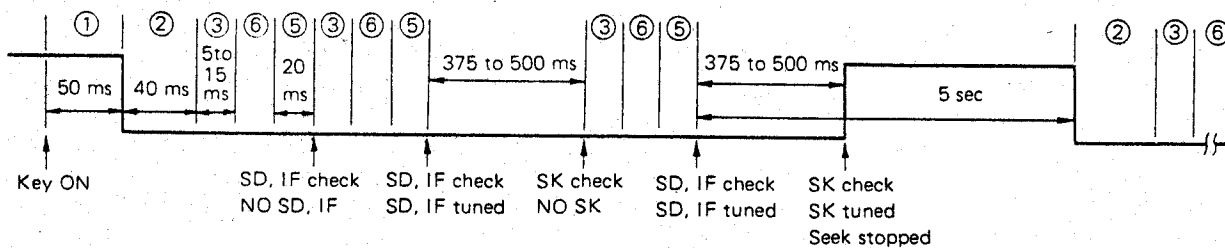

7) Band switching

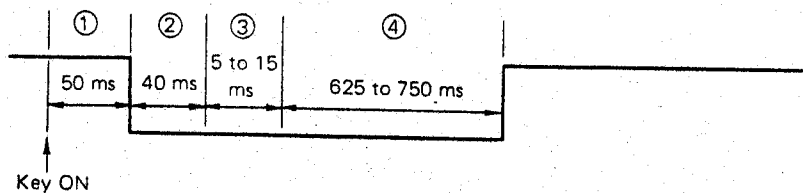

8) Radio OFF to ON

(1) RDSET switch

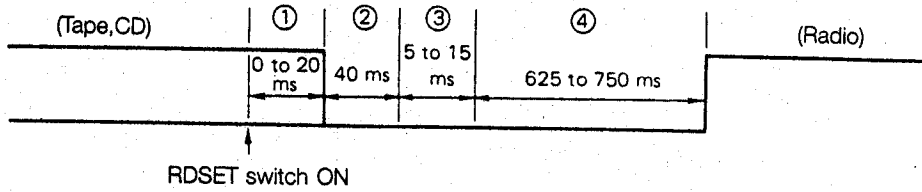

(2) CE : Low to High by RDON switch = 1

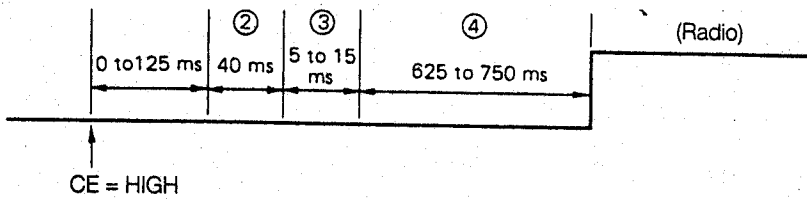

9) TAPE or CD OFF to ON

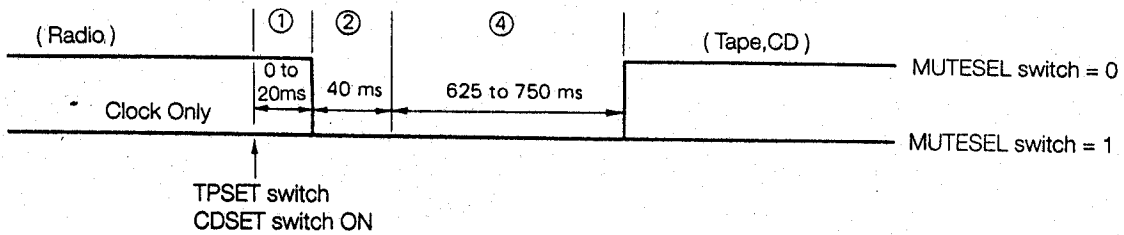

10) CE pin High to Low

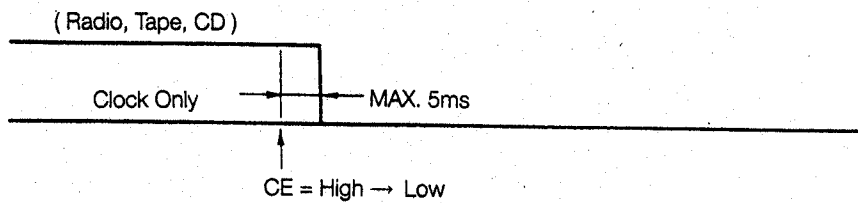

5.2 RADIO MUTE (RDMUTE PIN) AND AUDIO MUTE (AMUTE PIN) OUTPUT TIMING CHARTS

1) When switched from radio mode to tape or CD mode.

(Other than VF band, other than radio monitor mode)

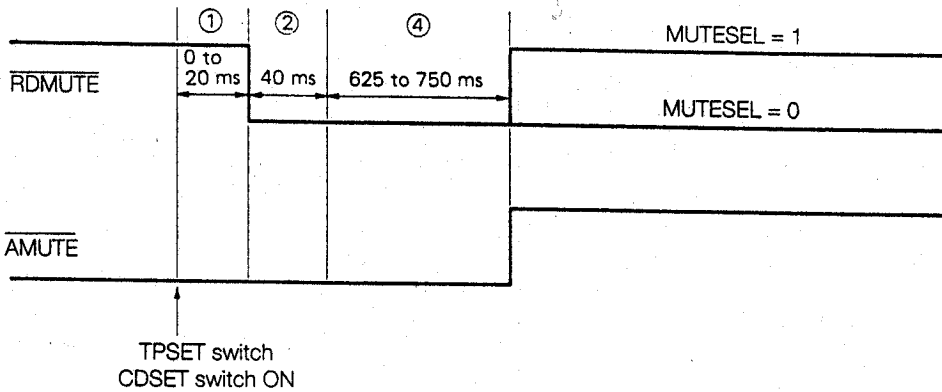

2) When switched from VF band to tape or CD mode (Set MUTESEL to 0)

(1) DK = OFF

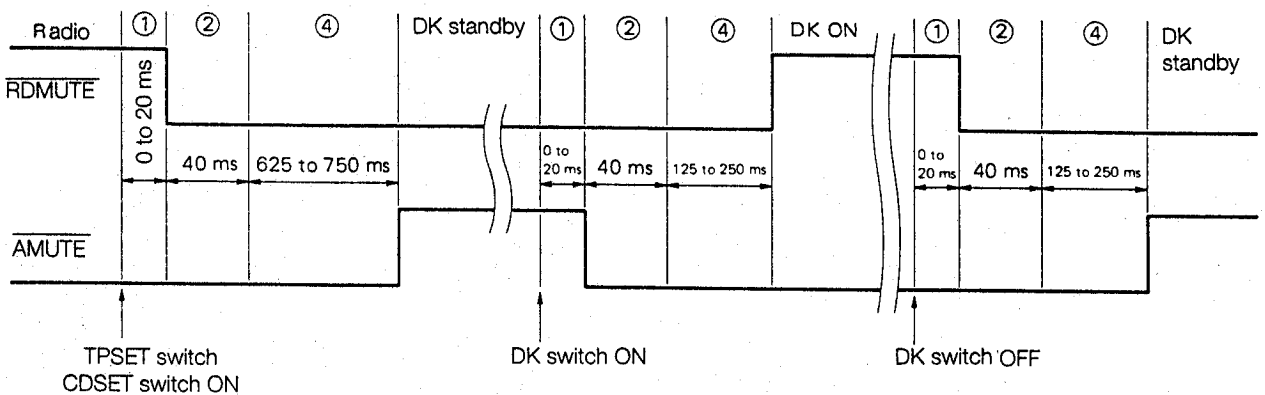

(2) DK = ON

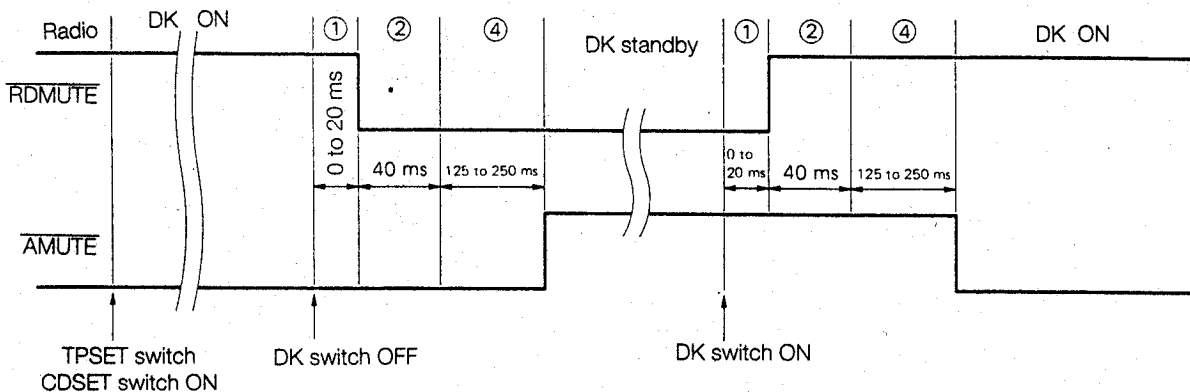

3) Radio monitor mode (Set MUTESEL to 0.)

(1) When switched from radio monitor OFF in the radio mode

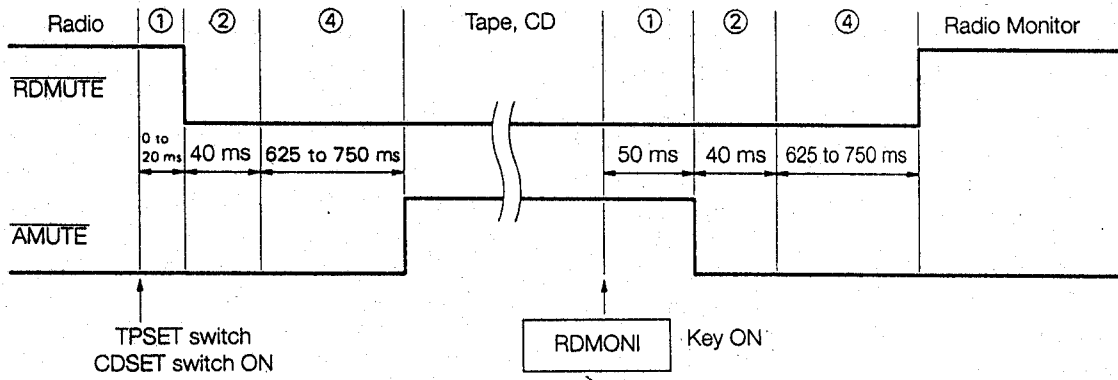

(2) When switched from radio monitor ON in radio mode

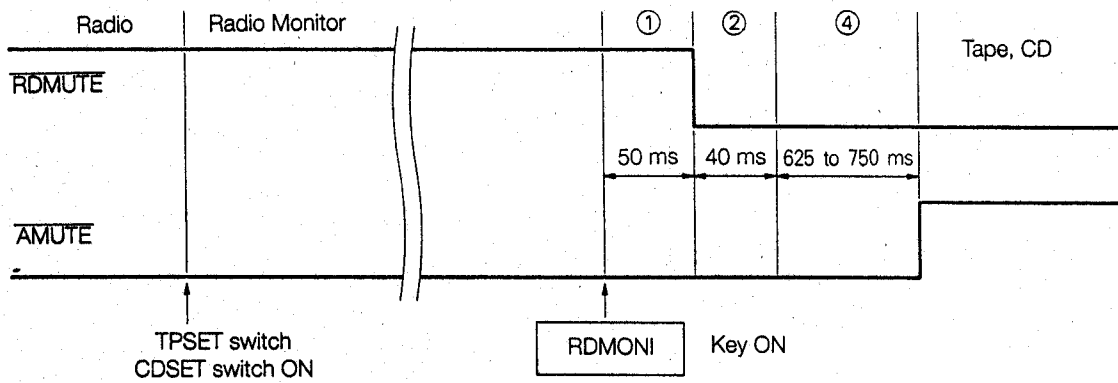

6. PIN I/O CIRCUITS

The I/O circuit of each pin of the DMC4002 is shown below in abbreviated form.

(1) LCD₀ / KS₀ to LCD₂₇, CGP, PB₀ to PB₃, PD₀ to PD₂, EO₁, EO₂

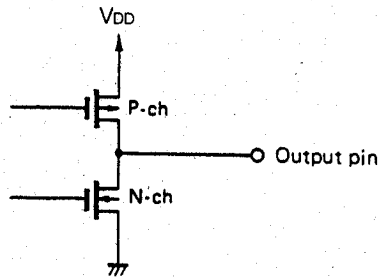

(2) INT, AD

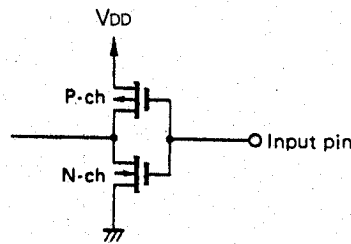

(3) PA₀ / AMIF, PA₁ / FMIF, PA₂, PA₃, PC₀ to PC₃

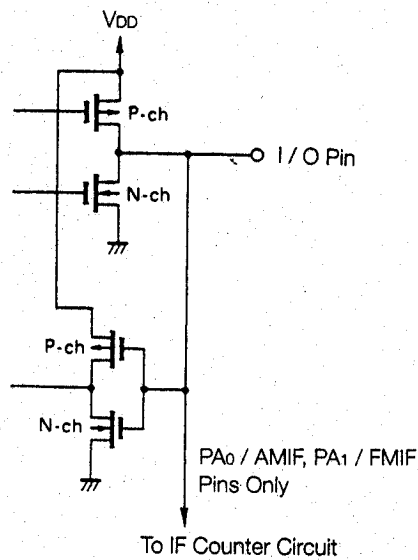

(4) COM₁, COM₂

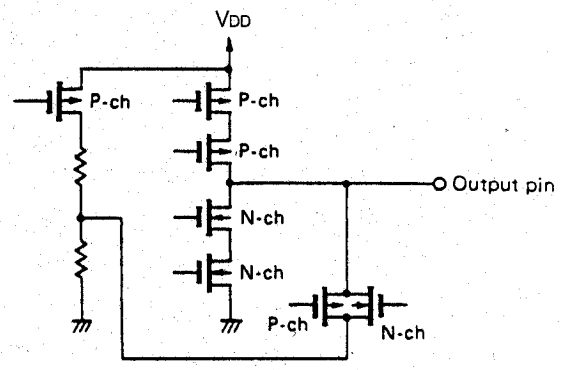

(5) Ko to K3

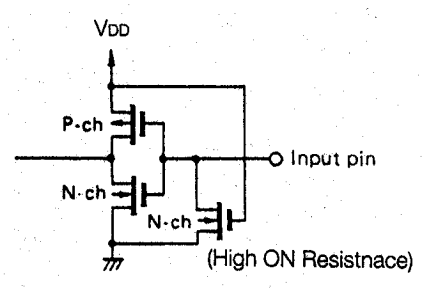

(6) FM VCO, AM VCO

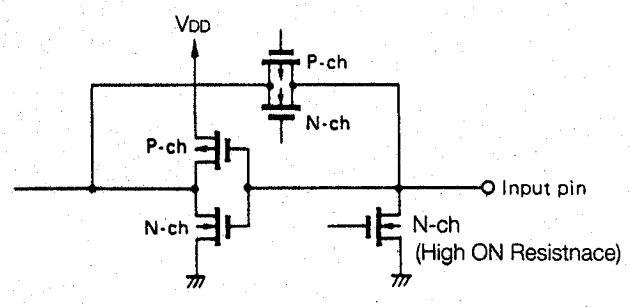

(7) CE

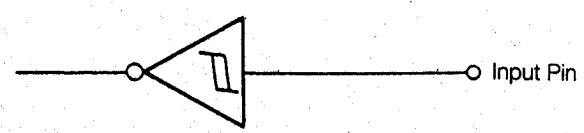

Schmitt Triggered input with Hysteresis Characteristics

7. APPLICATION CIRCUITS

7.1 Power ON/OFF by alternate switch () (No clock display in power OFF time)

RDON SWITCH = 1
RADIO ON (CE: Low to High)

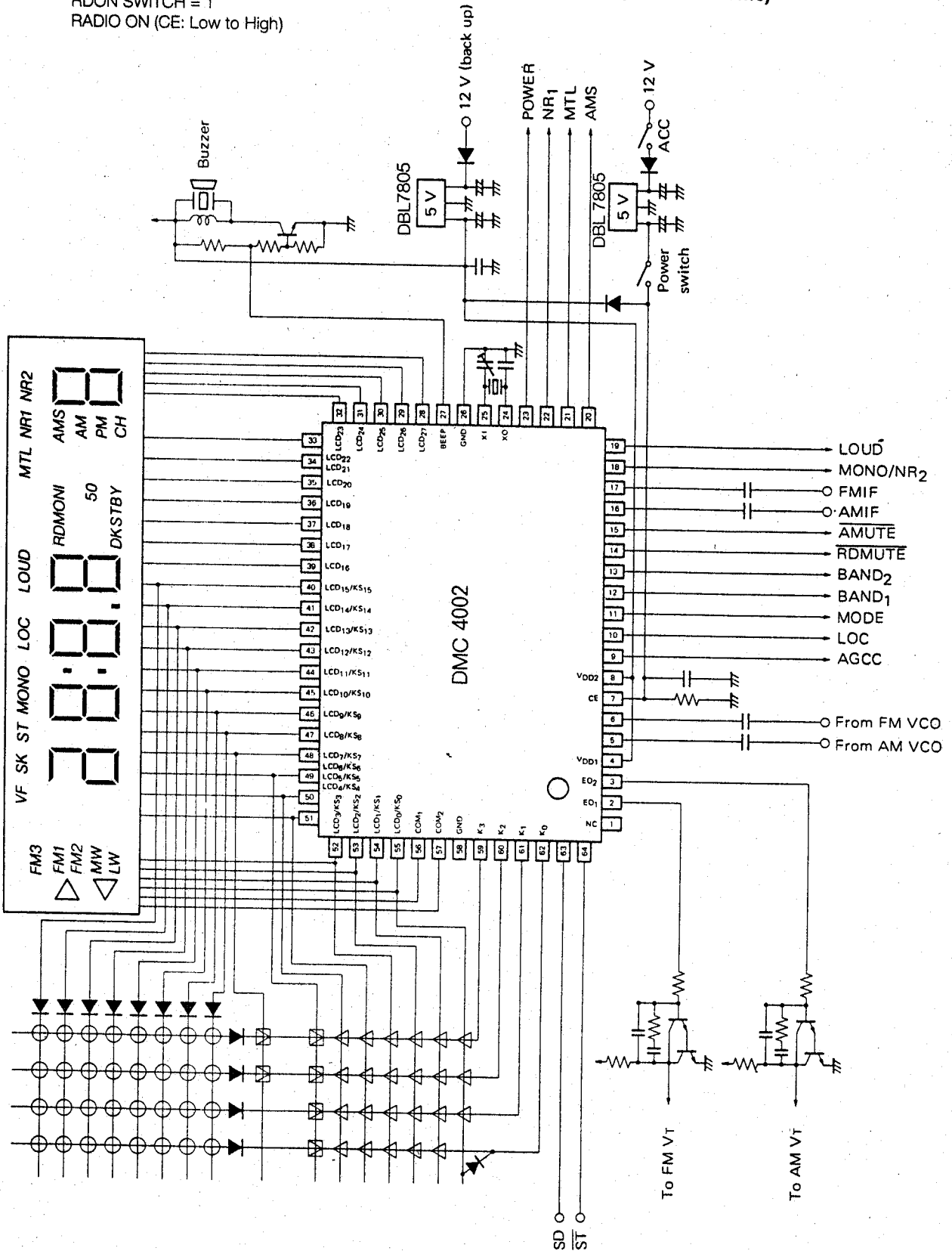

7.2 Power ON/OFF by alternate switch (○) (Clock display in power on time)

RDSET switch is used.

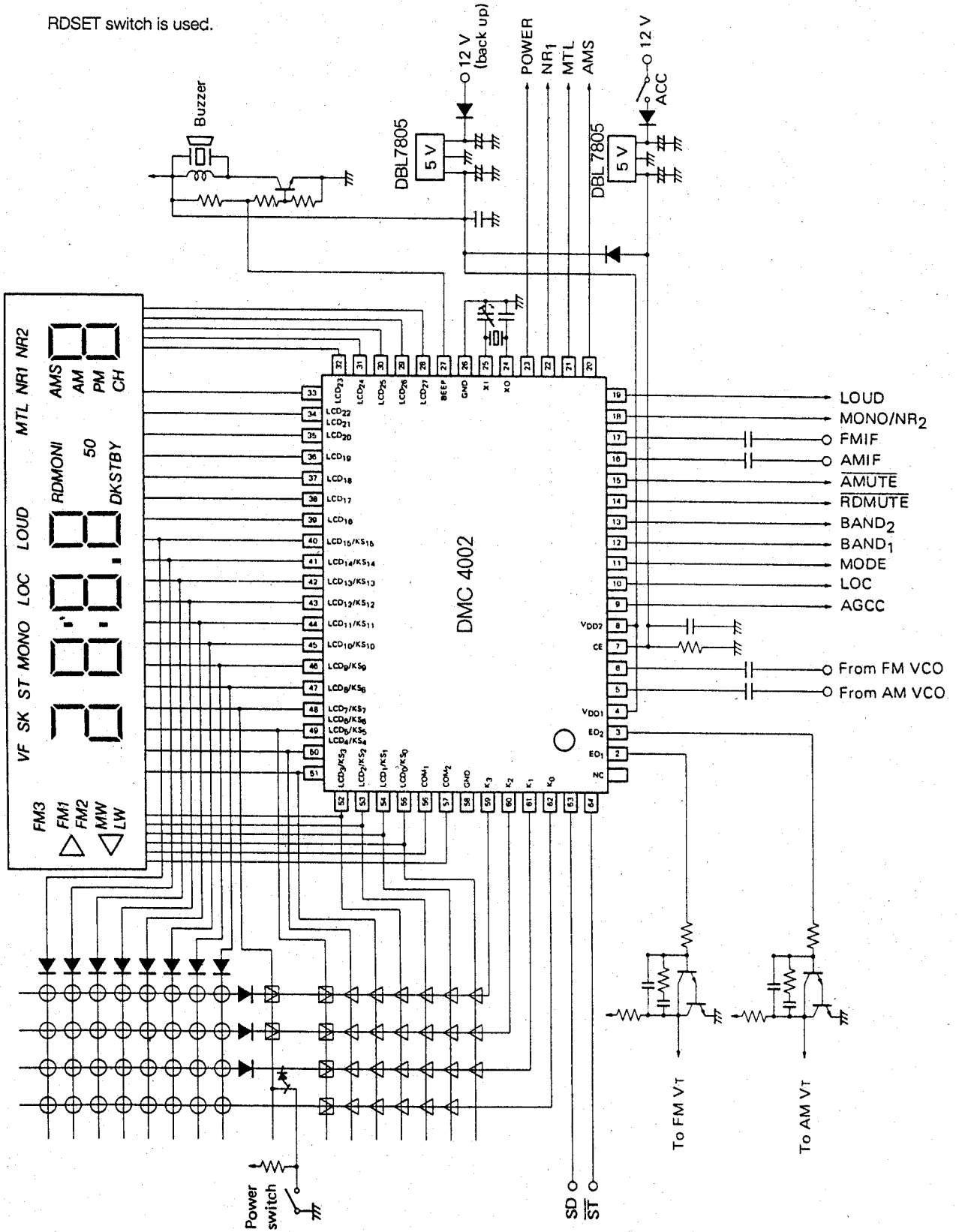

7.3 Power ON/OFF by momentary switch () (Clock display in power Off time)

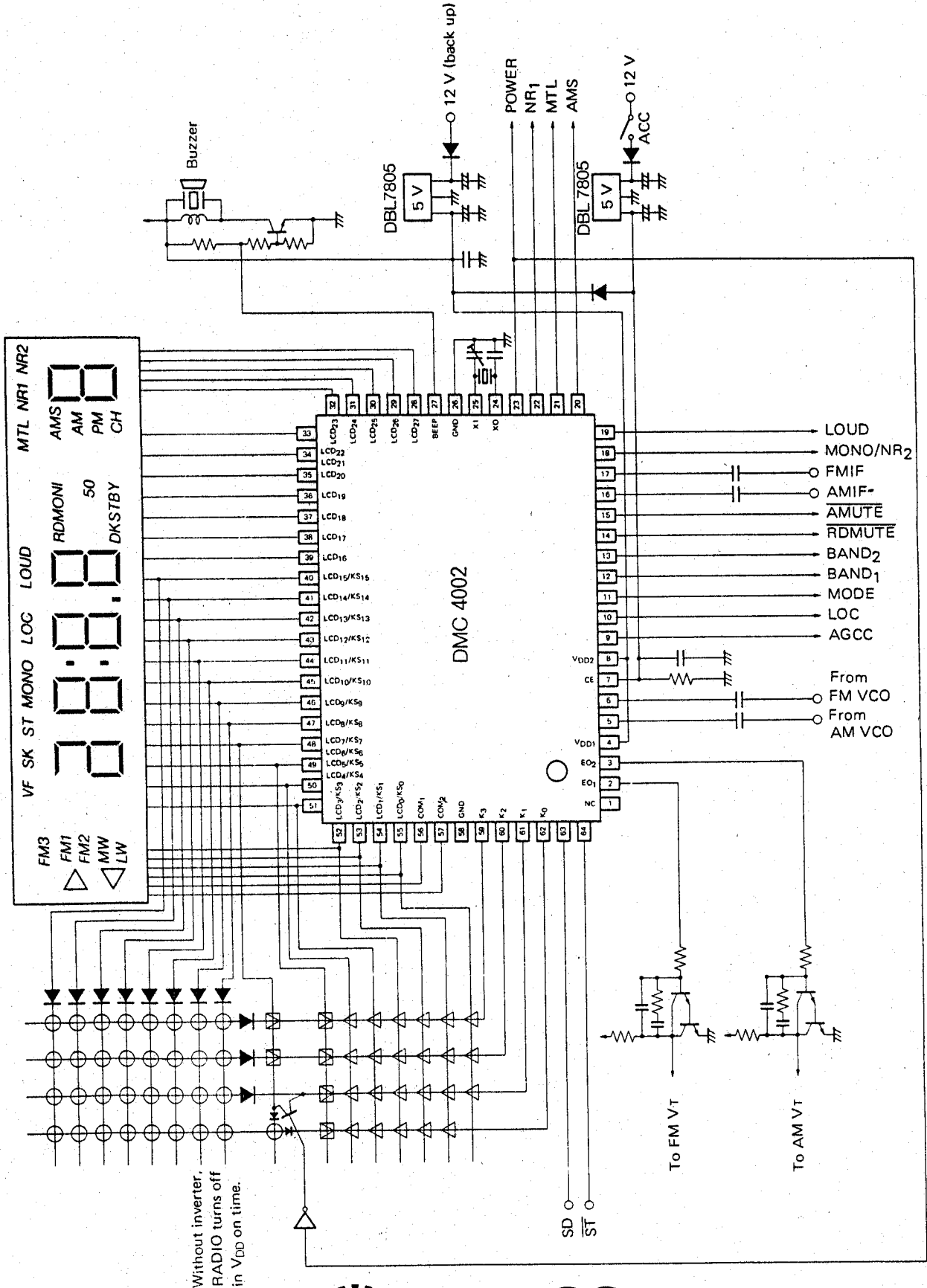

8. ELECTRICAL SPECIFICATIONS

□ MAXIMUM RATINGS

| Characteristic | Symbol | Rating | Unit |
|-----------------------|-------------------|--|------|
| Supply Voltage | V _{DD} | -0.3 ~ 6.0 | V |
| Input Voltage | V _{IN} | -0.3 ~ V _{DD} ^{+0.3} | V |
| Output Voltage | V _O | -0.3 ~ V _{DD} ^{+0.3} | V |
| Output Sink Current | I _{SINK} | 10 | mA |
| Operating Temperature | T _a | -40 ~ 85 | °C |
| Storage Temperature | T _{stg} | -55 ~ 125 | °C |

□ RECOMMENDED OPERATING RANGE

| Characteristic | Symbol | Test Condition | Min. | Typ. | Max. | Unit |
|--------------------------|-------------------|-------------------------------|------|------|-----------------|------------------|
| Supply Voltage | V _{DD1} | CPU, PLL operating | 4.5 | 5 | 5.5 | V |
| | V _{DD2} | PLL stopped | 3.5 | 5 | 5.5 | V |
| Date Hold Voltage | V _{DR} | X' tal oscillation stopped | 2.5 | | 5.5 | V |
| Supply Voltage Rise Time | T _{rise} | V _{DD} = Low to High | | | 500 | ms |
| Input Amplitude | V _{in1} | FM VCO, AM VCO Pin | 0.3 | | V _{DD} | V _{p-p} |
| | V _{in2} | AMIF, FMIF pin | 0.1 | | V _{DD} | V _{p-p} |

□ AC CHARACTERISTICS

(Unless otherwise specified, T_a = 25°C, V_{DD} = 4.5 to 5.5V)

| Characteristic | Symbol | Test Condition | Min. | Typ. | Max. | Unit |
|---------------------|------------------|--|------|------|------|------|
| Operating Frequency | f _{in1} | FM VCO pin (positive sine wave input) V _{in} = 0.3V _{p-p} | 10 | | 200 | MHz |
| | f _{in2} | AM VCO pin (positive sine wave input) V _{in} = 0.3V _{p-p} | 0.50 | | 30 | MHz |
| | f _{in3} | FMIF pin (positive sine wave input) V _{in} = 0.1V _{p-p} | 1 | | 20 | MHz |
| | f _{in4} | AMIF pin (positive sine wave input) V _{in} = 0.1V _{p-p} | 0.3 | | 5 | MHz |



□ DC CHARACTERISTICS

(Unless otherwise specified, $T_a = 25^\circ\text{C}$, $V_{DD} = 4.5$ to 5.5V)

| Characteristic | Symbol | Test Condition | Min. | Typ. | Max. | Unit |
|---------------------------------|------------|--|--------------|-----------|--------------|---------------|
| Input Voltage High | V_{IH1} | PORT A / C | $0.7 V_{DD}$ | | | V |
| | V_{IH2} | CE, $\overline{\text{INT}}$ | $0.8 V_{DD}$ | | | V |
| | V_{IH3} | K ₃ to K ₀ | $0.6 V_{DD}$ | | | V |
| Input Voltage Low | V_{IL1} | PORT A / C, CE, $\overline{\text{INT}}$ | | | $0.2 V_{DD}$ | V |
| | V_{IL2} | K ₃ to K ₀ | | | $0.15V_{DD}$ | V |
| Output Current High | I_{OH1} | PORT A / B / C / D $V_{OH} = V_{DD} - 0.4\text{V}$ | -0.4 | | | mA |
| | I_{OH2} | EO ₁ , EO ₂ , CGP, LCD ₂₇ to LCD ₂₄ $V_{OH} = V_{DD} - 1\text{V}$ | -0.5 | | | mA |
| | I_{OH3} | LCD ₀ to LCD ₂₃ $V_{OL} = V_{DD} - 1\text{V}$ | -200 | -280 | | μA |
| Output Current Low | I_{OL1} | PORT A / B / C / D, CGP, LCD ₂₇ to LCD ₂₄ $V_{OH} = 0.4\text{V}$ | 0.6 | | | mA |
| | I_{OL2} | EO ₁ , EO ₂ $V_{OL} = 1\text{V}$ | 0.5 | | | mA |
| | I_{OL3} | LCD ₀ to LCD ₂₃ $V_{OL} = 1\text{V}$ | 200 | 300 | | μA |
| Input Current High | I_{IH1} | K ₃ to K ₀ $V_1 = V_{DD} = 4.5\text{V}$ | 15 | 120 | 200 | μA |
| | I_{IH2} | FM / AM VCO, XI $V_1 = V_{DD} = 4.5\text{V}$ | 100 | | | μA |
| Output Voltage | V_{COM1} | COM1, COM2 $V_{DD} = 5\text{V}$, output open | 4.8 | 5.0 | | V |
| | V_{COM2} | COM1, COM2 $V_{DD} = 5\text{V}$, output open | 2.3 | 2.5 | 2.7 | V |
| | V_{COM3} | COM1, COM2 $V_{DD} = 5\text{V}$, output open | 0 | 0.2 | | V |
| Output off Leakage Current | I_{LEAK} | EO ₁ , EO ₂ $V_0 = V_{DD}$, $T_a = 25^\circ\text{C}$ | | 10^{-3} | 1 | μA |
| A/D Converter Resolution | | | | | 6 | bit |
| A/D Converter Absolute Accuracy | | $T_a = -10$ to $+50^\circ\text{C}$ | | 1 | 1.5 | LSB |
| Supply Current | I_{DD1} | CPU and PLL operating ($f_{in} = 150\text{MHz}$) $V_{DD} = 5\text{V}$, $T_a = 25^\circ\text{C}$ | | 20 | | mA |
| | I_{DD2} | PLL stopped, CPU operating $V_{DD} = 5\text{V}$, $T_a = 25^\circ\text{C}$ | | 0.5 | | mA |
| Data Hold Current | I_{DR} | X'tal oscillation stopped, $T_a = 25^\circ\text{C}$ $V_{DD} = 5\text{V}$ | | 20 | 400 | nA |
| A/D Input Resistance | R_1 | | 1 | | | M Ω |

9. PACKAGE DIMENSION

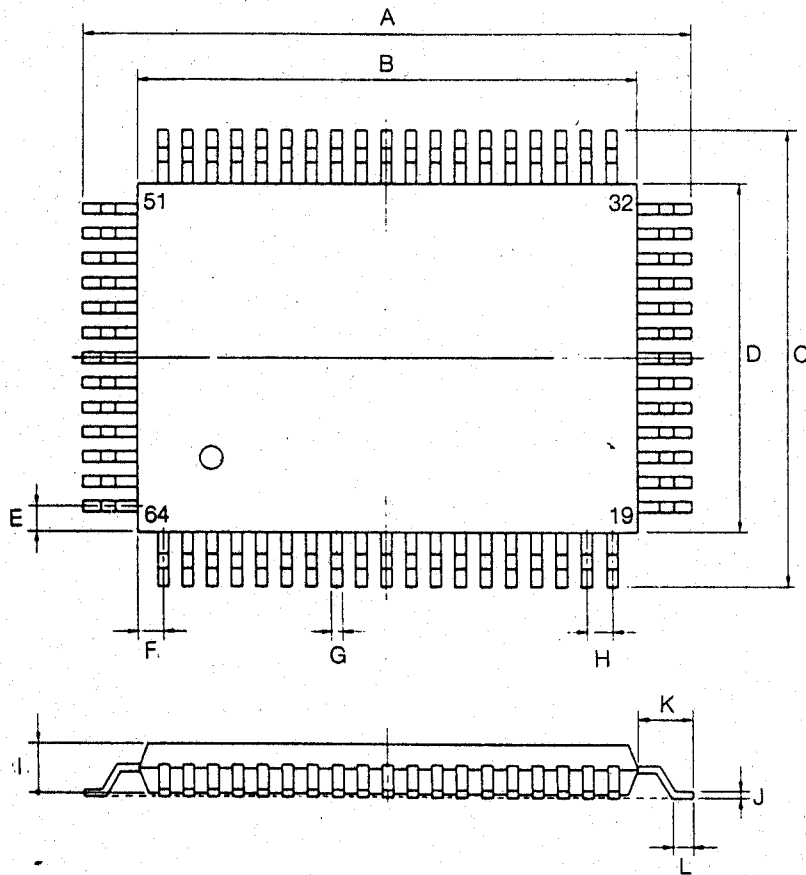

detail of lead end

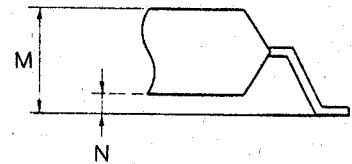

| | MILLIMETER | | | INCHE | | MILLIMETER | | | INCHE |
|---|------------|-------|-------|-------|---|------------|------|------|-------|
| | Min. | Typ. | Max. | Typ. | | Min. | Typ. | Max. | Typ. |
| A | 23.4 | 23.86 | 24.2 | .939 | H | — | 1.0 | — | .039 |
| B | 19.85 | 20.0 | 20.15 | .787 | I | 2.6 | 2.71 | 2.8 | .107 |
| C | 17.4 | 17.86 | 18.2 | .703 | J | 0.13 | 0.15 | 0.2 | .006 |
| D | 13.85 | 14.0 | 14.15 | .551 | K | 1.7 | 1.93 | 2.1 | .076 |
| E | — | 1.0 | — | .039 | L | 0.4 | 0.51 | 0.7 | .02 |
| F | — | 1.0 | — | .039 | M | — | 2.91 | 3.15 | .115 |
| G | 0.3 | 0.4 | 0.5 | .016 | N | 0.0 | 0.2 | 0.35 | .008 |

Note : Its specification is subject to change at any time without notice.