

**Features**

- Compatible with Microsoft Windows 2000 and 5-button Wheel Mouse
- Compatible with Microsoft Intelli 3D PS/2 and IBM PS/2 mouse
- Supports rolling buttons in PS/2 mouse mode
- X/Y axis photo input with built-in Holtek's special dynamic photo-input resistor
- Supports three buttons and three axes (X, Y, Z) inputs
- Z axis can support two kinds of scroller input (optomechanical and mechanical)
- 2MHz RC oscillator for system frequency with external pull-high resistor
- 16-pin DIP package

**General Description**

The HT82M398A is a Plug and Play WIN2000 and 5-button 3D PS/2 mouse controller. It is also compatible with Microsoft Intelli 3D PS/2

and IBM PS/2 mouse. The Z axis can support two kinds of scroller input, namely; mechanical and optomechanical.

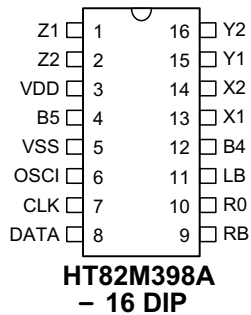
**Pin Assignment**

**Pin Description**

Pin No.	Pin Name	I/O	Description
1, 2	Z1, Z2	I	Z, axis input supports two kinds of scroller input, namely; optomechanical and mechanical.
3	VDD	—	Positive power supply
4	B5	I	Button 5, normal pull-low (50k $\Omega$ ), Press connect to high.
5	VSS	—	Negative power supply
6	OSCI	I	2MHz RC oscillator for system frequency with external pull-high resistor and built-in Capacitor.
7	CLK	I/O	CLK I/O, PS/2 mouse CLK line. NMOS open drain output with 5k $\Omega$ pull-high resistor.
8	DATA	I/O	DATA I/O, PS/2 mouse DATA line. NMOS open drain output with 5k $\Omega$ pull-high resistor.
9~11	RB, RO, LB	I	Right Button: Normal pull-low (50k $\Omega$ ), Pressing the button connects to high. Rolling Button: Normal pull-low (50k $\Omega$ ), Pressing the button connects to high. Left Button: Normal pull-low (50k $\Omega$ ), Pressing the button connects to high.
12	B4	I	Button 4, normal pull-low (50k $\Omega$ ), Press connect to high.
13~16	X1, X2, Y1, Y2	I	X/Y axis photo input with built-in Holtek's special dynamic photo input resistor

**Absolute Maximum Ratings**

Supply Voltage .....-0.3V to 6.5V      Storage Temperature.....-50°C to 125°C  
 Input Voltage .....V<sub>SS</sub>-0.3V to V<sub>DD</sub>+0.3V      Operating Temperature .....-25°C to 70°C

Note: These are stress ratings only. Stresses exceeding the range specified under "Absolute Maximum Ratings" may cause substantial damage to the device. Functional operation of this device at other conditions beyond those listed in the specification is not implied and prolonged exposure to extreme conditions may affect device reliability.

**Electrical Characteristics**

Ta=25°C

Symbol	Parameter	Test Conditions		Min.	Typ.	Max.	Unit
		V <sub>DD</sub>	Conditions				
V <sub>DD</sub>	Operating Voltage	—	—	4.5	5.0	5.5	V
I <sub>OP</sub>	Operating Current	5V	R <sub>OSC</sub> =120kΩ	—	—	15	mA
f <sub>OSC</sub>	RC Oscillator	5V	R <sub>OSC</sub> =120kΩ	1.6	2	2.2	V
V <sub>IL1</sub>	Input Low Voltage (Z1, Z2)	5V	—	0	—	1.5	V
V <sub>IH1</sub>	Input High Voltage (Z1, Z2)	5V	—	2.2	—	5	V
V <sub>IL2</sub>	Input Low Voltage (CLK, DATA)	5V	—	0	—	0.8	V
V <sub>IH2</sub>	Input High Voltage (CLK, DATA)	5V	—	2.0	—	5.0	V
R <sub>PH2</sub>	Pull-high Resistor (CLK, DATA)	5V	V <sub>IL</sub> =0V	2	5	10	kΩ
I <sub>sink</sub>	Sink Current (CLK, DATA)	5V	V <sub>OH</sub> =0.4V	4	—	—	mA
V <sub>IL3</sub>	Input Low Voltage (RB, Ro, LB)	5V	—	0	—	1.0	V
V <sub>IH3</sub>	Input High Voltage (RB, Ro, LB)	5V	—	1.8	—	5	V
R <sub>PL3</sub>	Pull-low Resistor (RB, Ro, LB)	5V	V <sub>IL</sub> =0V	3.0	60	125	kΩ
V <sub>IL4</sub>	Input Low Voltage (X1,X2,Y1,Y2)	5V	—	0	—	1.5	V
V <sub>IH4</sub>	Input High Voltage (X1, X2, Y1, Y2)	5V	—	2.2	—	5	V
R <sub>PL5</sub>	Dynamic Photo-resistor (X1, X2, Y1, Y2, Z1, Z2)	5V	—	See Dynamic resistor characteristics			

**Dynamic resistor characteristics**

- R-V curve

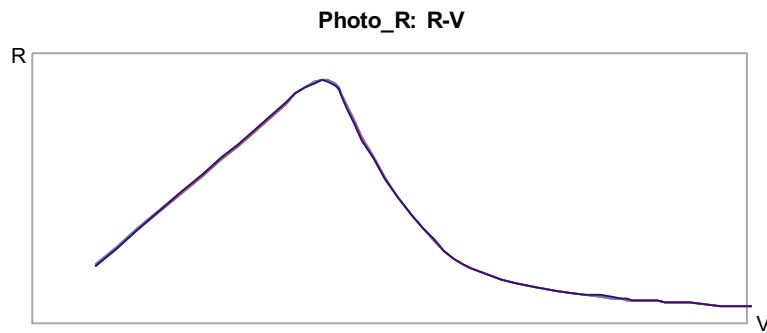

## Functional Description

### PS/2 mouse

- PS/2 status byte

Byte 1

bit

7: Reserved

6: 0=Stream Mode, 1=Remote Mode

5: 0=Disabled, 1=Enabled

4: 0=Scaling 1:1, 1=Scaling 2:1

3: 1=Wrap Mode, 0=Stream or Remote  
(different from IBM specs.)

2: 1=Left Button Pressed

1: 1=Middle Button Pressed

0: 1=Right Button Pressed

Byte 2

Bit 0~7 current resolution setting  
(Bit 0=LSB)

Byte 3

Bit 0~7 current sampling rate (Bit 0=LSB)

- Standard PS/2 data format

Variable rps, 0, 8, 1, bidirectional, synchronous

Bit No.	7	6	5	4	3	2	1	0
1st word	YV	XV	YS	XS	1	M	R	L
2nd word	X7	X6	X5	X4	X3	X2	X1	X0
3rd word	Y7	Y6	Y5	Y4	Y3	Y2	Y1	Y0

- Data format for 3D PS/2

Variable rps, 0, 8, 1, bidirectional, synchronous

Bit No.	7	6	5	4	3	2	1	0
1st word	0	0	YS	XS	1	M	R	L
2nd word	X7	X6	X5	X4	X3	X2	X1	X0
3rd word	Y7	Y6	Y5	Y4	Y3	Y2	Y1	Y0
4th word	Z7	Z6	Z5	Z4	Z3	Z2	Z1	Z0

The x/y data report is 9-bit 2's complement

The z data report is 8-bit 2's complement

- Data format for 5-button Wheel Mouse

Bit No.	7	6	5	4	3	2	1	0
1st word	0	0	YS	XS	1	M	R	L
2nd word	X7	X6	X5	X4	X3	X2	X1	X0
3rd word	Y7	Y6	Y5	Y4	Y3	Y2	Y1	Y0
4th word	0	0	B5	B4	Z3	Z2	Z1	Z0

X movement towards the right is positive, moving towards the left is negative

Y upward movement is positive, moving down is negative

Z rolling towards the user is positive, else negative

Button status: 1=pressed, 0=released

- 5-button Wheel Mouse Mode follows the 5-button Activation Method of Windows 2000 and the 5-button Wheel Mouse Specification.

- ♦ Any time the PC sends a reset "FFh" command to the mouse, it will reset the mouse to Standard PS/2 mode.

- ♦ After power-on reset is initiated, the mouse is set to Standard PS/2 mode.

**Timing Diagrams**

**X, Y axis photo-coupler cross width**

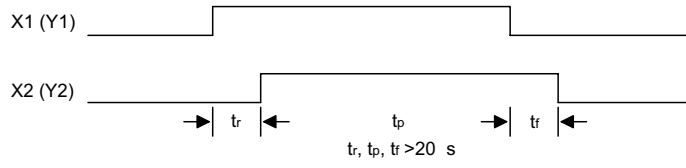

**X/Y/Z axis counting**

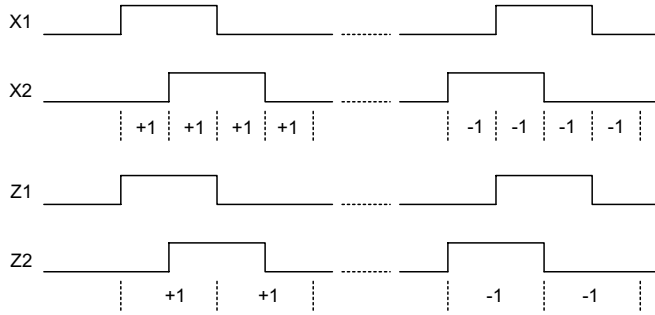

**PS/2 mouse**

• **Data output**

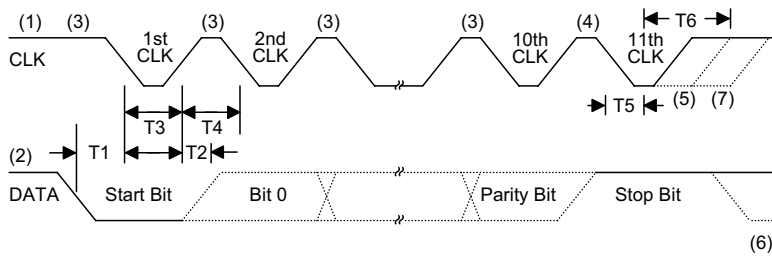

Timing Parameter	Min./Max.
T1 DATA transition to the falling edge of CLK	5/25 sec
T2 Rising edge of CLK to DATA transition	5/T4-5 sec
T3 Inactive CLK Duration	30/50 sec
T4 Active CLK Duration	30/50 sec
T5 Minimum time to inhibit MOUSE after clock 11	>0 sec
T6 Maximum time to inhibit MOUSE after clock 11 to ensure MOUSE does not start another transmission	<50 sec

• **Data input**

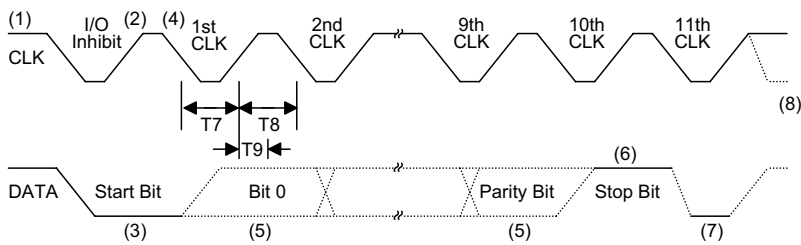

Timing Parameter	Min./Max.
T7 CLK Duration, low	30/50 sec
T8 CLK Duration, high	30/50 sec
T9 Time from low to high CLK transition to time when MOUSE samples DATA line	5/25 sec

Application Circuits

HT82M398A Z axis optomechanical (this application circuit is for reference only)

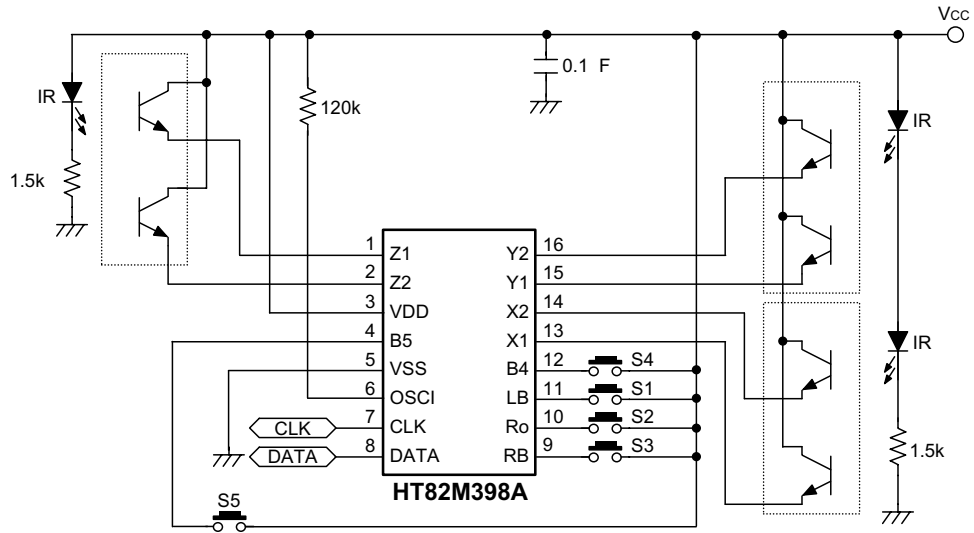

HT82M398A Z axis mechanical (this application circuit is for reference only)

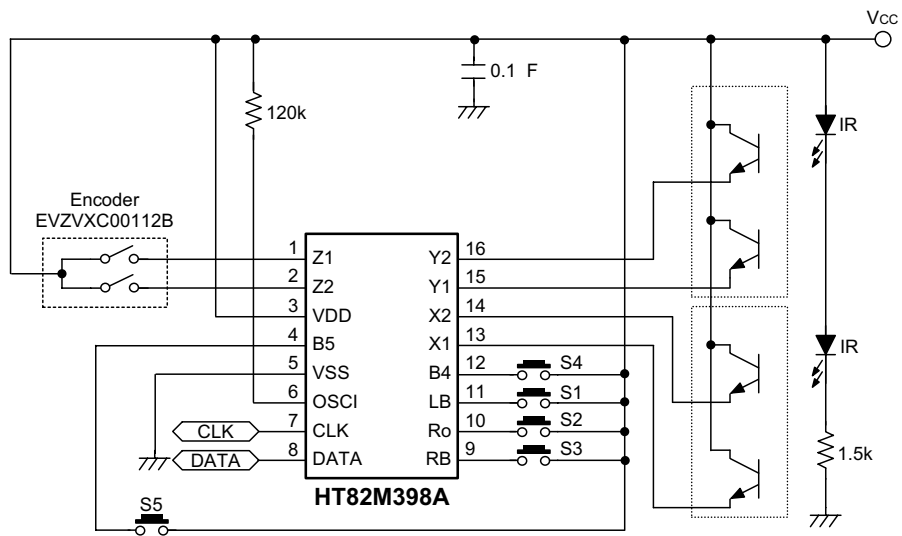

**Holtek Semiconductor Inc. (Headquarters)**

No.3 Creation Rd. II, Science-based Industrial Park, Hsinchu, Taiwan, R.O.C.  
Tel: 886-3-563-1999  
Fax: 886-3-563-1189

**Holtek Semiconductor Inc. (Taipei Office)**

5F, No.576, Sec.7 Chung Hsiao E. Rd., Taipei, Taiwan, R.O.C.  
Tel: 886-2-2782-9635  
Fax: 886-2-2782-9636  
Fax: 886-2-2782-7128 (International sales hotline)

**Holtek Semiconductor (Hong Kong) Ltd.**

RM.711, Tower 2, Cheung Sha Wan Plaza, 833 Cheung Sha Wan Rd., Kowloon, Hong Kong  
Tel: 852-2-745-8288  
Fax: 852-2-742-8657

Copyright © 2000 by HOLTEK SEMICONDUCTOR INC.

The information appearing in this Data Sheet is believed to be accurate at the time of publication. However, Holtek assumes no responsibility arising from the use of the specifications described. The applications mentioned herein are used solely for the purpose of illustration and Holtek makes no warranty or representation that such applications will be suitable without further modification, nor recommends the use of its products for application that may present a risk to human life due to malfunction or otherwise. Holtek reserves the right to alter its products without prior notification. For the most up-to-date information, please visit our web site at <http://www.holtek.com.tw>.