

DATA SHEET

For a complete data sheet, please also download:

- The IC04 LOCMOS HE4000B Logic Family Specifications HEF, HEC
- The IC04 LOCMOS HE4000B Logic Package Outlines/Information HEF, HEC

HEF4541B **MSI** Programmable timer

Product specification
File under Integrated Circuits, IC04

January 1995

Programmable timer

HEF4541B
MSI

DESCRIPTION

The HEF4541B is a programmable timer which consists of a 16-stage binary counter, an integrated oscillator to be used with external timing components, an automatic power-on reset and output control logic. The frequency of the oscillator is determined by the external components R_T and C_T within the frequency range 1 Hz to 100 kHz. This oscillator may be replaced by an external clock signal at input RS, the timer advances on the positive-going transition of RS. A LOW on the auto reset input (\overline{AR}) and a LOW on the master reset input (MR) enables the internal power-on reset. A HIGH level at input MR resets the counter independent on all other inputs. Resetting

disables the oscillator to provide no active power dissipation.

A HIGH at input \overline{AR} turns off the power-on reset to provide a low quiescent power dissipation of the timer. The 16-stage counter divides the oscillator frequency by 2^8 , 2^{10} , 2^{13} or 2^{16} depending on the state of the address inputs (A_0 , A_1). The divided oscillator frequency is available at output O. The phase input (PH) features a complementary output signal. If the mode select input (MODE) is LOW or HIGH the timer can be used respectively as a single transition timer or 2^n frequency divider.

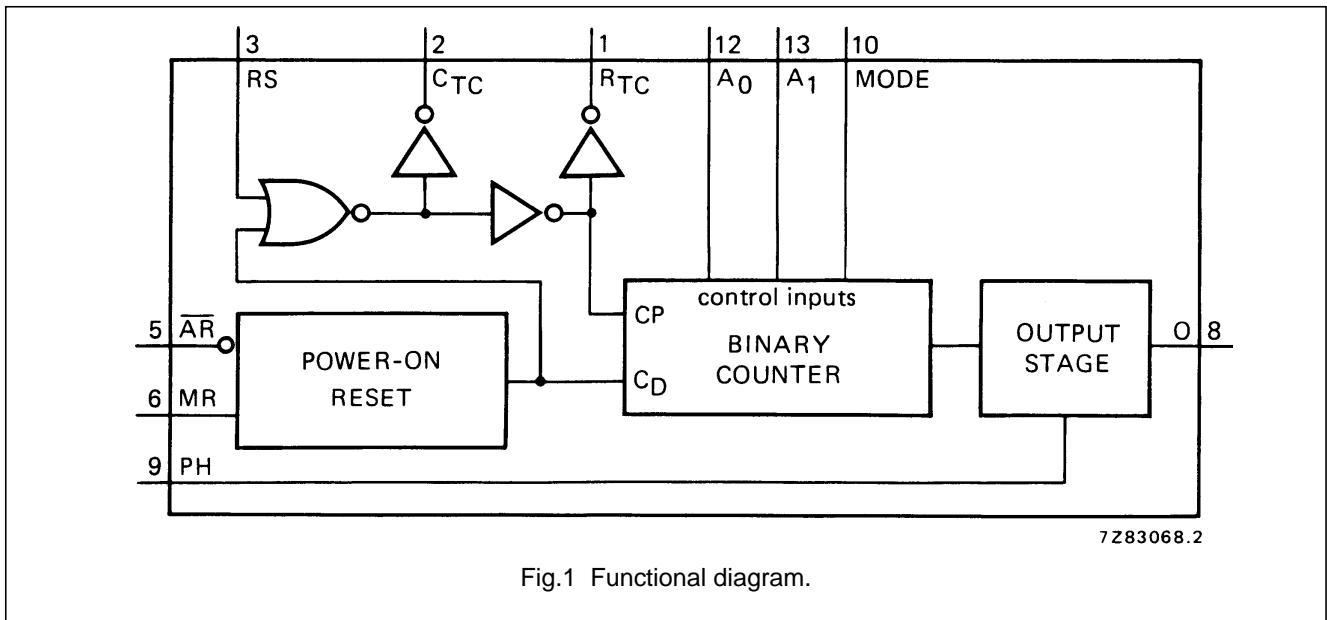

Fig.1 Functional diagram.

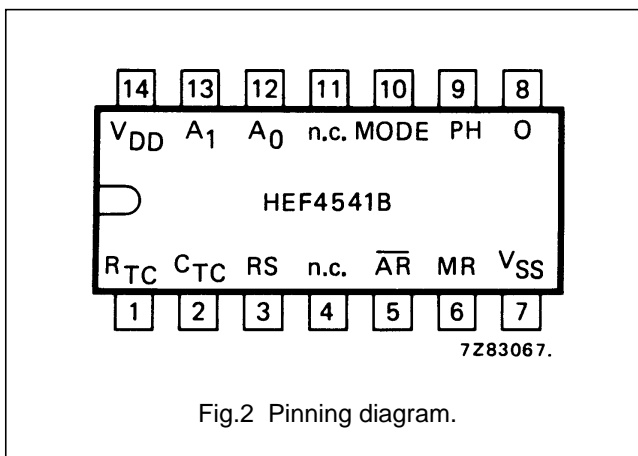

Fig.2 Pinning diagram.

- HEF4541BP(N): 14-lead DIL; plastic (SOT27-1)
 - HEF4541BD(F): 14-lead DIL; ceramic (cerdip) (SOT73)
 - HEF4541BT(D): 14-lead SO; plastic (SOT108-1)
- (): Package Designator North America

FAMILY DATA, I_{DD} LIMITS category MSI

See Family Specifications

Programmable timer

HEF4541B
MSI

PINNING

- A₀, A₁ address inputs
- MODE mode select input
- \overline{AR} auto reset input
- MR master reset input
- PH phase input
- R_{TC} external resistor connection (R_t)
- C_{TC} external capacitor connection (C_t)
- RS external resistor connection (R_S) or external clock input

FREQUENCY SELECTION TABLE

A ₀	A ₁	NUMBER OF COUNTER STAGES n	$\frac{f_{osc}}{f_{out}} = 2^n$
L	L	13	8 192
L	H	10	1 024
H	L	8	256
H	H	16	65 536

FUNCTION TABLE

INPUTS				MODE
\overline{AR}	MR	PH	MODE	
H	L	X	X	auto reset disabled
L	L	X	X	auto reset enabled ⁽¹⁾
X	H	X	X	master reset active
X	L	X	H	normal operation selected
X	L	X	L	division to output
X	L	L	X	single-cycle mode ⁽²⁾
X	L	L	X	output initially LOW, after reset
X	L	H	X	output initially HIGH, after reset

Notes

1. For correct power-on reset, the supply voltage should be above 8.5 V. For V_{DD} < 8.5 V, disable the autoreset and connect \overline{AR} to V_{DD}.
2. The timer is initialized on a reset pulse and the output changes state after 2ⁿ⁻¹ counts and remains in that state (latched). Reset of this latch is obtained by master reset or by a LOW to HIGH transition on the MODE input.

H = HIGH state (the more positive voltage)
 L = LOW state (the less positive voltage)
 X = state is immaterial

RC oscillator

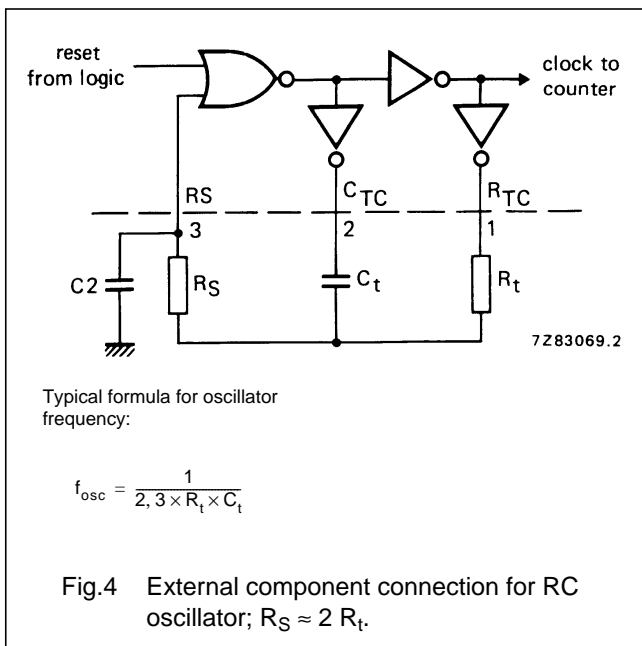

Timing component limitations

The oscillator frequency is mainly determined by R_tC_t, provided R_t << R_S and R_SC₂ << R_tC_t. The function of R_S is to minimize the influence of the forward voltage across the input protection diodes on the frequency. The stray capacitance C₂ should be kept as small as possible. In consideration of accuracy, C_t must be larger than the inherent stray capacitance. R_t must be larger than the LOC MOS 'ON' resistance in series with it, which typically is 500 Ω at V_{DD} = 5 V, 300 Ω at V_{DD} = 10 V and 200 Ω at V_{DD} = 15 V.

The recommended values for these components to maintain agreement with the typical oscillation formula are:
 C_t ≥ 100 pF, up to any typical value,
 10 kΩ ≤ R_t ≤ 1 MΩ.

Programmable timer

HEF4541B
MSI

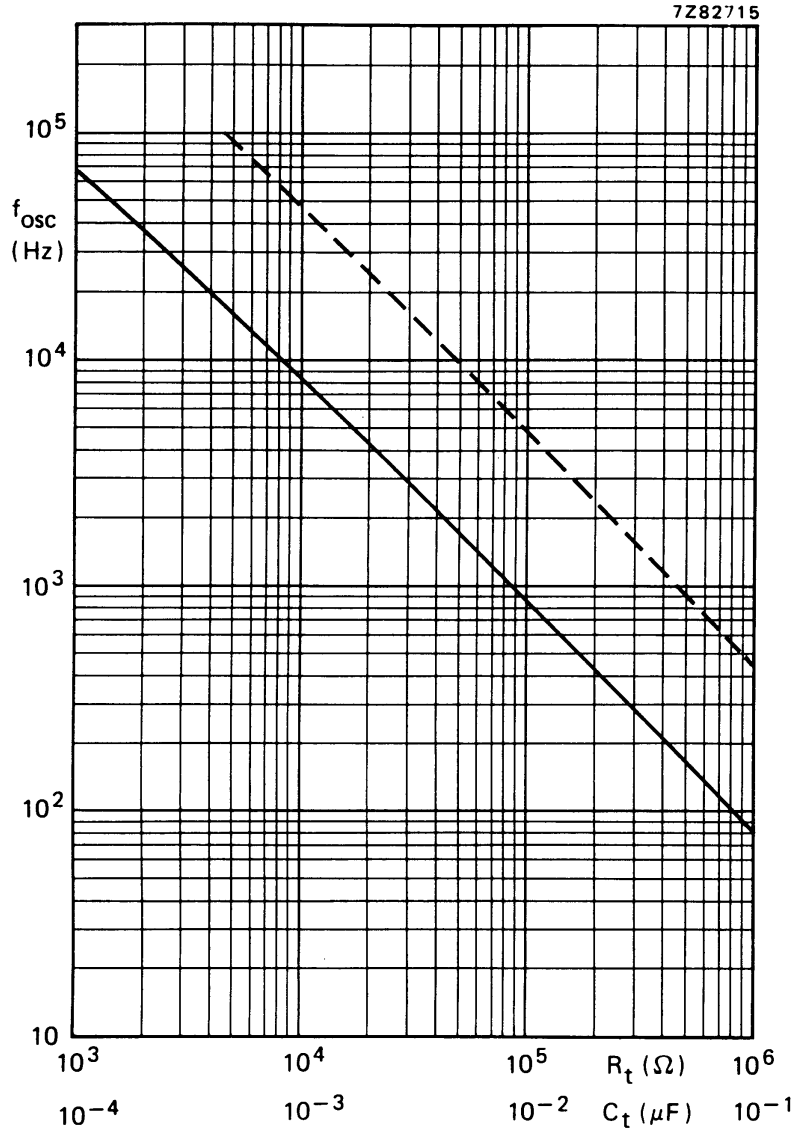

— C_t curve at $R_t = 56 \text{ k}\Omega$; $R_S = 120 \text{ k}\Omega$.
 - - - R_t curve at $C_t = 1 \text{ nF}$; $R_S = 2 R_t$.

Fig.5 RC oscillator frequency as a function of R_t and C_t at $V_{DD} = 5 \text{ to } 15 \text{ V}$; $T_{amb} = 25 \text{ }^\circ\text{C}$.

Programmable timer

HEF4541B
MSI

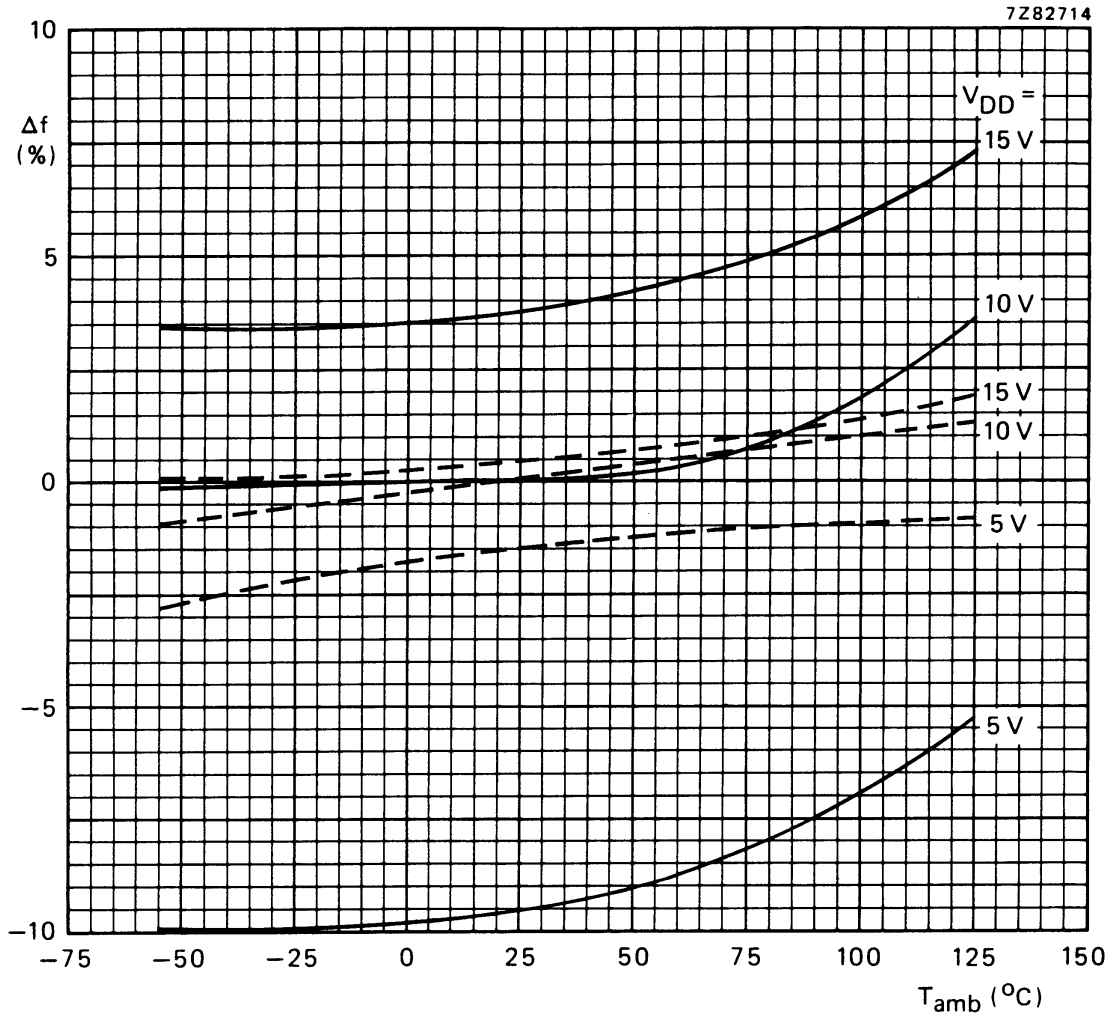

— $R_t = 56\text{ k}\Omega$; $C_t = 1\text{ nF}$; $R_S = 0$.
 --- $R_t = 56\text{ k}\Omega$; $C_t = 1\text{ nF}$; $R_S = 120\text{ k}\Omega$.

Fig.6 Frequency deviation (Δf) as a function of ambient temperature; referenced at : f_{osc} at $T_{amb} = 25\text{ }^{\circ}C$ and $V_{DD} = 10\text{ V}$.

Programmable timer

HEF4541B
MSI

DC CHARACTERISTICS

 $V_{SS} = 0\text{ V}$

	V_{DD} V	V_{OL} V	V_{OH} V	SYMBOL	T_{amb} (°C)							
					-40		+25		+85			
					MIN.	MAX.	MIN.	TYP.	MAX.	MIN.	MAX.	
Supply current	5				-	80	-	20	80	-	230	μA
power-on reset enabled (note)	10			I_D	-	750	-	250	600	-	700	μA
	15				-	1600	-	500	1300	-	1500	μA
Supply voltage for automatic reset initialization (note)				V_{DD}	-	-	8,5	5	-	-	-	V
Output current HIGH; C_{TC} , R_{TC}	5		4,6		0,5	-	0,4	-	-	0,3	-	mA
	10		9,5	$-I_{OH}$	1,4	-	1,2	-	-	0,95	-	mA
	15		13,5		4,8	-	4,0	-	-	3,2	-	mA
	5		2,5	$-I_{OH}$	1,4	-	1,2	-	-	0,95	-	mA
Output current LOW; C_{TC} , R_{TC}	5	0,4			0,33	-	0,27	-	-	0,20	-	mA
	10	0,5		I_{OL}	1,00	-	0,85	-	-	0,68	-	mA
	15	1,5			3,20	-	2,70	-	-	2,30	-	mA

Note

1. All inputs at 0 V or V_{DD} ; except input \overline{AR} = input MR = 0 V (power-on reset active).

AC CHARACTERISTICS

 $V_{SS} = 0\text{ V}$; $T_{amb} = 25\text{ }^\circ\text{C}$; input transition times $\leq 20\text{ ns}$

	V_{DD} V	TYPICAL FORMULA FOR P (μW) ⁽¹⁾
Dynamic power dissipation per package (P)	5	1 300 $f_i + f_o C_L V_{DD}^2$
	10	5 300 $f_i + f_o C_L V_{DD}^2$
	15	12 000 $f_i + f_o C_L V_{DD}^2$
Total power dissipation when using the on-chip oscillator (P)	5	1 300 $f_{osc} + f_o C_L V_{DD}^2 + 2C_t V_{DD}^2 f_{osc} + 10 V_{DD}$
	10	5 300 $f_{osc} + f_o C_L V_{DD}^2 + 2C_t V_{DD}^2 f_{osc} + 100 V_{DD}$
	15	12 000 $f_{osc} + f_o C_L V_{DD}^2 + 2C_t V_{DD}^2 f_{osc} + 400 V_{DD}$

Notes

1. where:

f_i = input frequency (MHz)

f_o = output frequency (MHz)

C_L = load capacitance (pF)

V_{DD} = supply voltage (V)

C_t = timing capacitance (pF)

f_{osc} = oscillator frequency (MHz)

Programmable timer

HEF4541B
MSI

AC CHARACTERISTICS

 $V_{SS} = 0\text{ V}$; $T_{amb} = 25\text{ }^{\circ}\text{C}$; $C_L = 50\text{ pF}$; input transition times $\leq 20\text{ ns}$

	V_{DD} V	SYMBOL	MIN.	TYP.	MAX.	TYPICAL EXTRAPOLATION FORMULA	
Propagation delays RS \rightarrow O	2^8 selected	t_{PHL} ; t_{PLH}		375	750	ns	$348\text{ ns} + (0,55\text{ ns/pF}) C_L$
			HIGH to LOW	150	300	ns	$139\text{ ns} + (0,23\text{ ns/pF}) C_L$
			LOW to HIGH	110	220	ns	$102\text{ ns} + (0,16\text{ ns/pF}) C_L$
	2^{10} selected	t_{PHL} ; t_{PLH}		425	850	ns	$398\text{ ns} + (0,55\text{ ns/pF}) C_L$
			HIGH to LOW	165	330	ns	$154\text{ ns} + (0,23\text{ ns/pF}) C_L$
			LOW to HIGH	120	240	ns	$112\text{ ns} + (0,16\text{ ns/pF}) C_L$
	2^{13} selected	t_{PHL} ; t_{PLH}		510	1020	ns	$483\text{ ns} + (0,55\text{ ns/pF}) C_L$
			HIGH to LOW	190	380	ns	$179\text{ ns} + (0,23\text{ ns/pF}) C_L$
			LOW to HIGH	135	270	ns	$127\text{ ns} + (0,16\text{ ns/pF}) C_L$
	2^{16} selected	t_{PHL} ; t_{PLH}		575	1150	ns	$548\text{ ns} + (0,55\text{ ns/pF}) C_L$
			HIGH to LOW	210	420	ns	$199\text{ ns} + (0,23\text{ ns/pF}) C_L$
			LOW to HIGH	150	300	ns	$142\text{ ns} + (0,16\text{ ns/pF}) C_L$
Minimum clock pulse width; LOW	5	t_{WRSL}	60	30	ns		
	10		30	15	ns		
	15		24	12	ns		
Minimum reset pulse width; HIGH	5	t_{WMRH}	60	30	ns		
	10		30	15	ns		
	15		24	12	ns		
Maximum clock pulse frequency	5	f_{max}	8	16	MHz		
	10		15	30	MHz		
	15		18	36	MHz		
Oscillator frequency	5	f_{osc}		90	kHz	$R_t = 5\text{ k}\Omega$	
	10			90	kHz	$C_t = 1\text{ nF}$	
	15			90	kHz	$R_S = 10\text{ k}\Omega$	
Oscillator frequency	5	f_{osc}		8	kHz	$R_t = 56\text{ k}\Omega$	
	10			8	kHz	$C_t = 1\text{ nF}$	
	15			8	kHz	$R_S = 120\text{ k}\Omega$	