

## GaAs MMIC DOUBLE-BALANCED MIXER, 6 - 18 GHz

### Typical Applications

The HMC141 & HMC142 is ideal for:

- UNII & HiperLAN
- Microwave & MMW Radios
- Military, Space & Test Equipment

### Functional Diagram

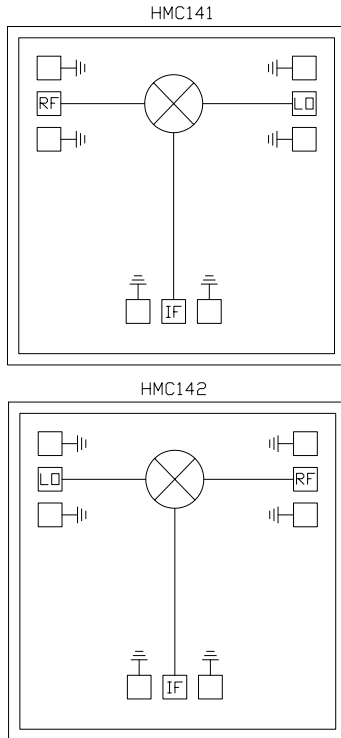

### Features

- Input IP3: +21 dBm
- LO / RF Isolation: 25 to 40 dB
- IF Bandwidth: DC to 6 GHz
- Small Size: 1.48mm x 1.48mm

### General Description

The HMC141 chip is a miniature double-balanced mixer which can be used as an upconverter or downconverter. The HMC142 is identical to the HMC141 except that the layout is a mirror image designed to ease integration into image-reject mixer modules. Broadband operation and excellent isolations are provided by on-chip baluns, which require no external components and no DC bias. The design is similar to the HMC143/144 mixers but without an IF combiner, providing a broad DC to 6 GHz IF bandwidth. These devices are much smaller and more reliable than hybrid diode mixers for VSAT and point-to-point radios.

### Electrical Specifications, $T_A = +25^\circ C$ , LO Drive = +20 dBm

Parameter	Min.	Typ.	Max.	Units
Frequency Range, RF & LO		6 - 18		GHz
Frequency Range, IF		DC - 6		GHz
Conversion Loss		10	12	dB
Noise Figure (SSB)		10	12	dB
LO to RF Isolation	20	25		dB
LO to IF Isolation	20	25		dB
IP3 (Input)	16	21		dBm
IP2 (Input)	40	47		dBm
1 dB Gain Compression (Input)	5	10		dBm

# HMC141 / HMC142

## GaAs MMIC DOUBLE-BALANCED MIXER, 6 - 18 GHz

### Conversion Loss

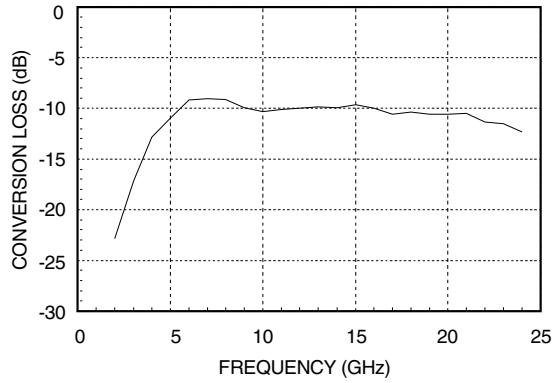

### Isolation

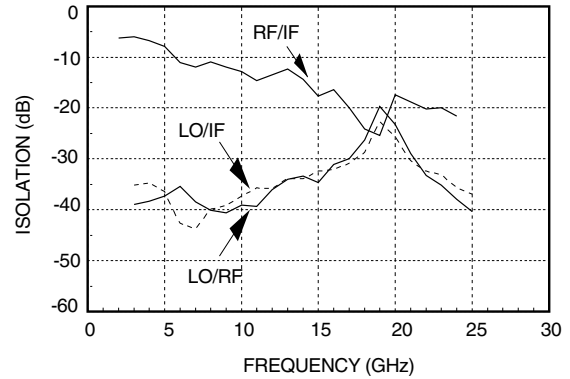

### Conversion Loss vs. LO Drive Level @ Several RF Frequencies

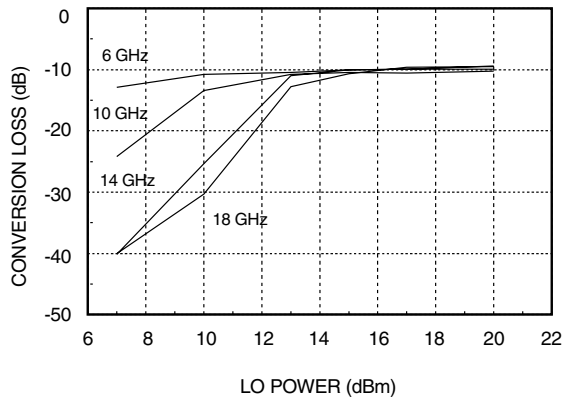

### Upconverter Performance

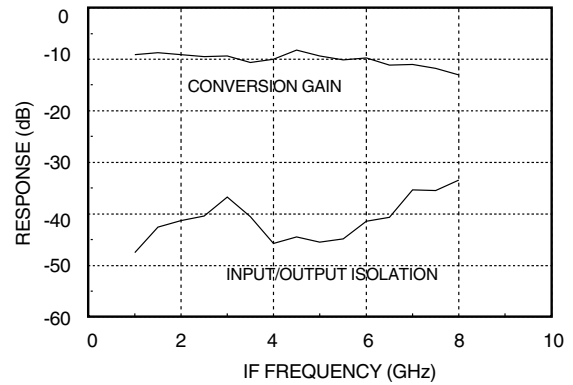

Input at IF Port (1-8 GHz); Output at LO Port (9 GHz)  
Local Oscillator at RF Port (10-17 GHz)

## GaAs MMIC DOUBLE-BALANCED MIXER, 6 - 18 GHz

**RF Return Loss**

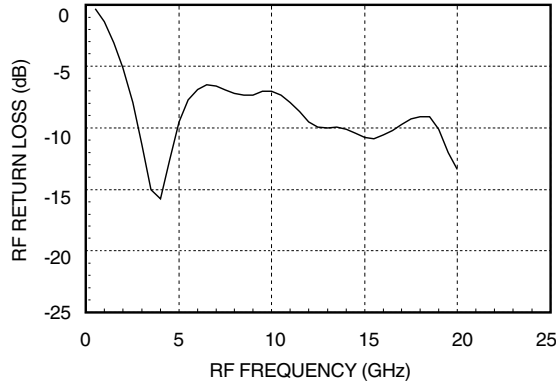

**LO Return Loss**

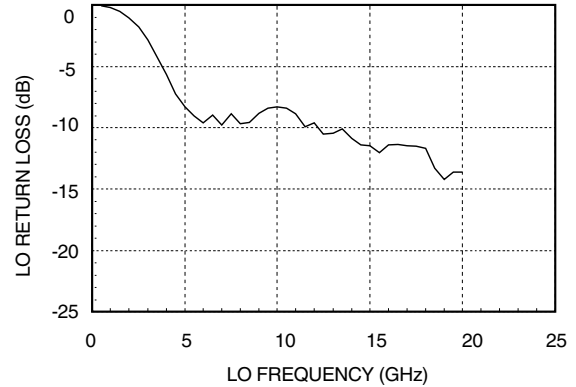

**IF Return Loss**

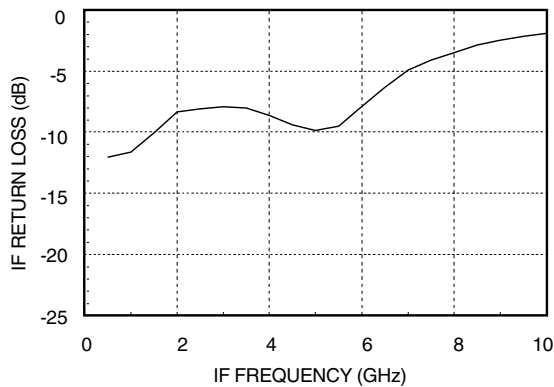

**Distortion and 1dB Compression versus LO Drive Level**

LO Drive (dBm)	Distortion		1 dB Compression P1dB (dBm)
	IP3 (dBm)	IP2 (dBm)	
+13	18	42	7
+15	21	45	10
+17	21	45	10

RF (f1) = 11.01 GHz  
RF (f2) = 11.00 GHz  
LO = 11.5 GHz  
RF Level = 0 dBm

### Absolute Maximum Ratings

LO Drive	+27 dBm
Storage Temperature	-65 to +150 °C
Operating Temperature	-55 to +85 °C

## GaAs MMIC DOUBLE-BALANCED MIXER, 6 - 18 GHz

**Outline Drawings** (See HMC141/142 Operation Application Note in Section 15)

### HMC141

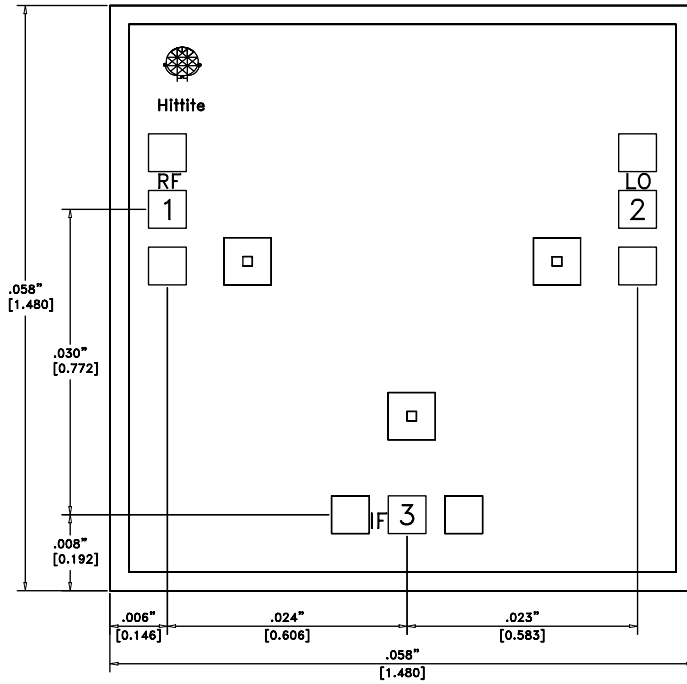

### HMC142

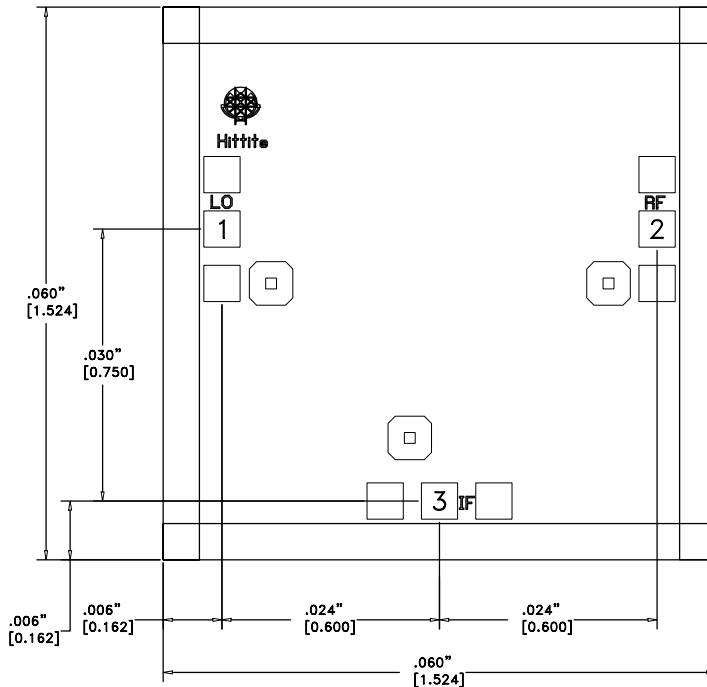

**NOTES:**

1. ALL DIMENSIONS ARE IN INCHES [MM].
2. DIE THICKNESS IS .004".
3. TYPICAL BOND PAD IS .004" SQUARE.
4. BACKSIDE METALLIZATION: GOLD.
5. BOND PAD METALLIZATION: GOLD.
6. BACKSIDE METAL IS GROUND.
7. CONNECTION NOT REQUIRED FOR UNLABELED BOND PADS.