

#### DC/DC Converter Controller

The KIA34063A/AF series is a monolithic control circuit containing the primary functions required for DC-to-DC converters. These devices consist of an internal temperature compensated reference, comparator, controlled duty cycle oscillator with an active current limit circuit, driver and high current output switch. This series was specifically designed to be incorporated in Step-Down and Step-Up and Voltage-Inverting applications with a minimum number of external components.

#### FEATURES

- Operation from 3.0V to 40V input.
- Low Standby Current.
- Current Limiting.
- Output Switch Current to 1.5A.
- Output Voltage Adjustable.
- Frequency Operation to 100kHz.
- Precision 2% Reference.

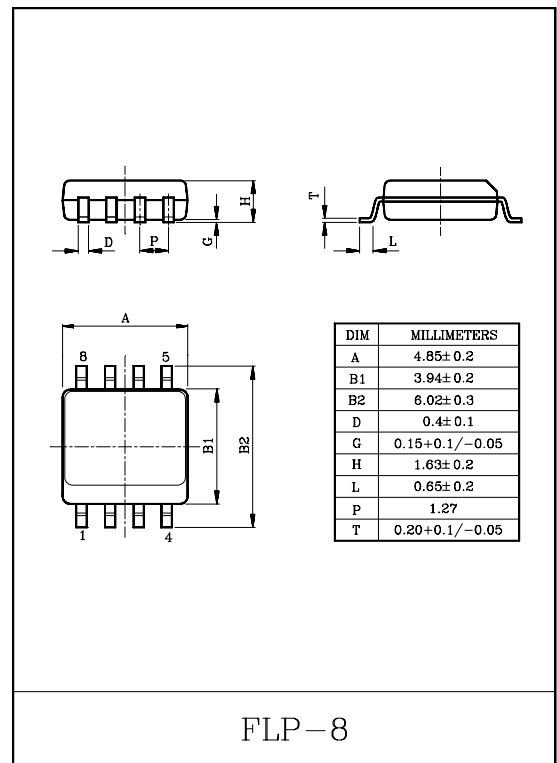
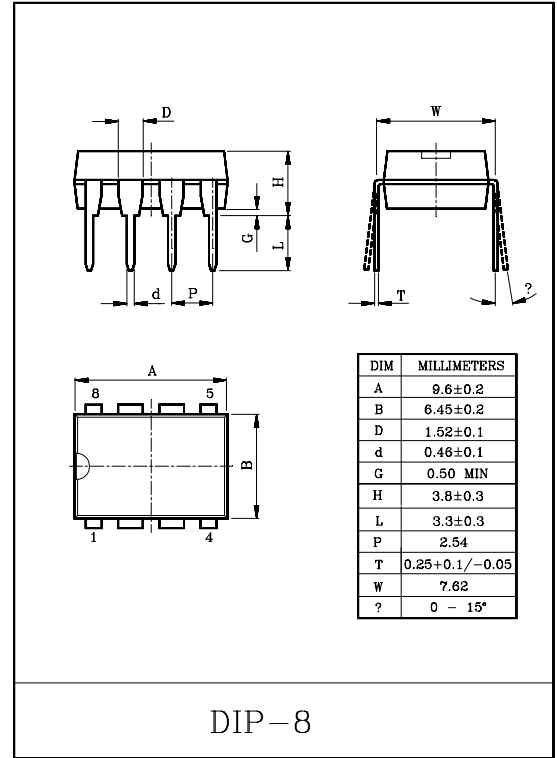
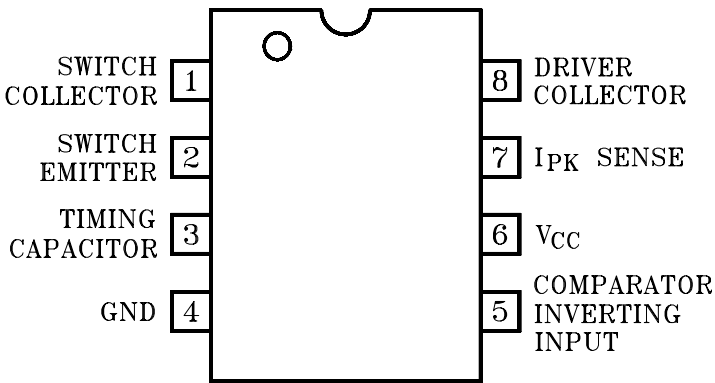

# KIA34063A/AF

MAXIMUM RATINGS (Ta=25°C)

CHARACTERISTIC		SYMBOL	RATING	UNIT
Power Supply Voltage		$V_{CC}$	40	V
Comparator Input Voltage Range		$V_{IR}$	-30~40	V
Switch Collector Voltage		$V_{C(SWITCH)}$	40	V
Switch Emitter Voltage ( $V_{PIN1}=40V$ )		$V_{E(SWITCH)}$	40	V
Switch Collector to Emitter Voltage		$V_{CE(SWITCH)}$	40	V
Driver Collector Voltage		$V_{C(DRIVER)}$	40	V
Driver Collector Current (Note 1)		$I_{C(DRIVER)}$	100	mA
Switch Current		$I_{SW}$	1.5	A
Power Dissipation	KIA34063A	$P_D$	500	mW
	KIA34063AF		320	
Operating Temperature		$T_{opr}$	-30~75	°C
Storage Temperature		$T_{stg}$	-65~150	°C

Note) 1. Maximum package power dissipation limits must be observed.

## BLOCK DIAGRAM

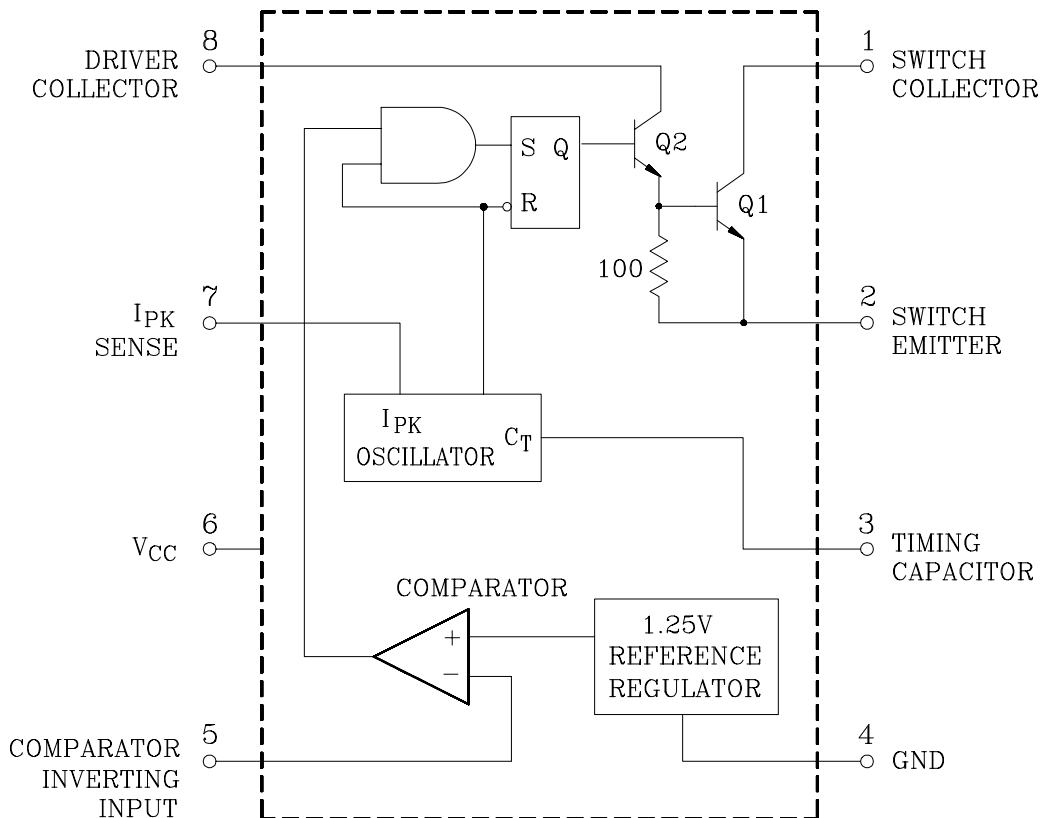

# KIA34063A/AF

ELECTRICAL CHARACTERISTICS (V<sub>CC</sub>=5.0V, T<sub>a</sub>=25°C, unless otherwise specified)

## OSCILLATOR SECTION

CHARACTERISTIC	SYMBOL	TEST CONDITION	MIN.	TYP.	MAX.	UNIT
Frequency	f <sub>OSC</sub>	V <sub>PIN5</sub> =0V, C <sub>T</sub> =1.0nF	24	33	42	kHz
Charge Current	I <sub>CHG</sub>	V <sub>CC</sub> =5.0~40V	24	35	42	μA
Discharge Current	I <sub>DISCHG</sub>	V <sub>CC</sub> =5.0~40V	140	220	260	μA
Discharge to Charge Current Ratio	I <sub>DISCHG</sub> /I <sub>CHG</sub>	Pin 7~V <sub>CC</sub>	5.2	6.5	7.5	-
Current Limit Sense Voltage	V <sub>IPK(SENSE)</sub>	I <sub>DISCHG</sub> =I <sub>CHG</sub>	250	300	350	mV

## OUTPUT SWITCH SECTION (Note 2)

CHARACTERISTIC	SYMBOL	TEST CONDITION	MIN.	TYP.	MAX.	UNIT
Saturation Voltage, Darlington Connection	V <sub>CE(SAT1)</sub>	I <sub>SW</sub> =1.0A, Pins 1, 8 Connection	-	1.0	1.3	V
Saturation Voltage (Note 3)	V <sub>CE(SAT2)</sub>	I <sub>SW</sub> =1.0A, Forced β = ≈20 R <sub>PIN8</sub> =82Ω to V <sub>CC</sub>	-	0.45	0.7	V
DC Current Gain	h <sub>FE</sub>	I <sub>SW</sub> =1.0A, V <sub>CE</sub> =5.0A,	50	75	-	-
Collector Off-State Current	I <sub>C(OFF)</sub>	V <sub>CE</sub> =40V	-	0.01	100	μA

## COMPARATOR SECTION

CHARACTERISTIC	SYMBOL	TEST CONDITION	MIN.	TYP.	MAX.	UNIT
Threshold Voltage	V <sub>TH1</sub>	T <sub>a</sub> =25°C	1.225	1.25	1.275	V
Threshold Voltage	V <sub>TH2</sub>	T <sub>a</sub> =T <sub>LOW</sub> ~T <sub>HIGH</sub>	1.21	-	1.29	V
Threshold Voltage Line Regulation	Reg line	V <sub>CC</sub> =3.0~40V	-	1.4	5.0	mV
Input Bias Current	I <sub>IB</sub>	V <sub>IN</sub> =0	-	-20	-400	nA

## TOTAL DEVICE

CHARACTERISTIC	SYMBOL	TEST CONDITION	MIN.	TYP.	MAX.	UNIT
Supply Current	I <sub>CC</sub>	V <sub>CC</sub> =5.0~40V, C <sub>T</sub> =1.0nF, Pin 7=V <sub>CC</sub> , Pin 2=GND, V <sub>PIN5</sub> > V <sub>TH</sub> , remaining pins open	-	-	4.0	mA

Note) 2. Low duty cycle pulse techniques are used during test to maintain junction temperature as close to ambient temperature as possible.

3. If the output switch is driven into hard saturation (non-Darlington configuration) at low switch currents (≤300mA) and high driver currents (≥30mA), it may take up to 2.0μS for it to come out of saturation. This condition will shorten the off time at frequencies ≥30kHz, and is magnified at high temperatures. This condition does not occur with a Darlington configuration, since the output switch cannot saturate. If a non-Darlington configuration is used, the following output drive condition is recommended ;

$$\text{Forced } \beta \text{ of output switch : } \frac{I_{C \text{ output}}}{I_{C \text{ driver}} - 7.0 \text{ mA}^*} \geq 10$$

\* The 100Ω resistor in the emitter of the driver device requires about 7.0mA before the output switch conducts.

# KIA34063A/AF

## APPLICATION CIRCUIT

### (1) Step-up Converter

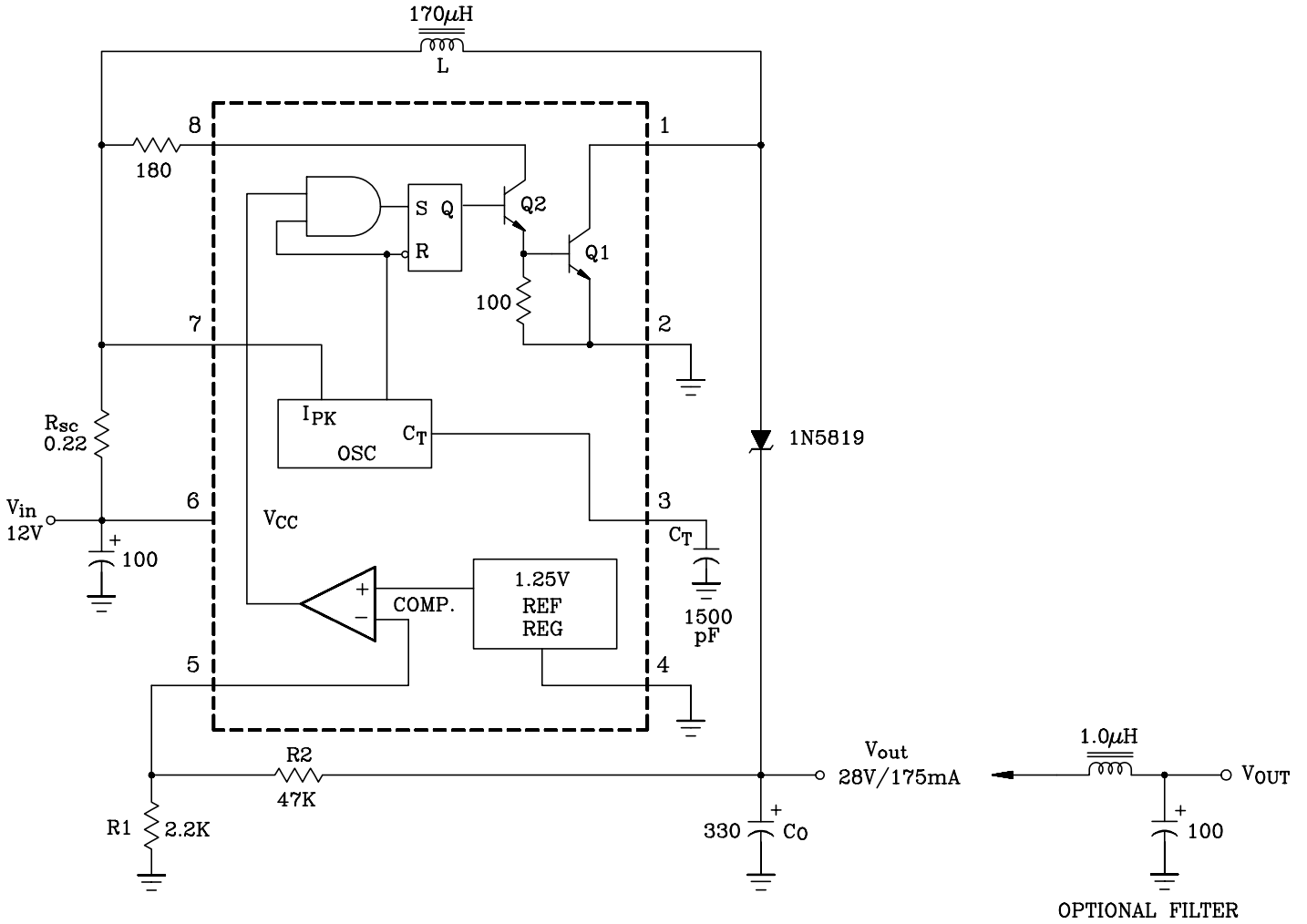

TEST	CONDITIONS	RESULTS
Line Regulation	$V_{IN}=8.0V$ to $16V$ , $I_O=175mA$	$30mV=\pm 0.05\%$
Load Regulation	$V_{IN}=12V$ , $I_O=75mA$ to $175mA$	$10mV=\pm 0.017\%$
Output Ripple	$V_{IN}=12V$ , $I_O=175mA$	400 mVpp
Efficiency	$V_{IN}=12V$ , $I_O=175mA$	87.7%
Output Ripple With Optional Filter	$V_{IN}=12V$ , $I_O=175mA$	40 mVpp

## (2) Step-Down Converter

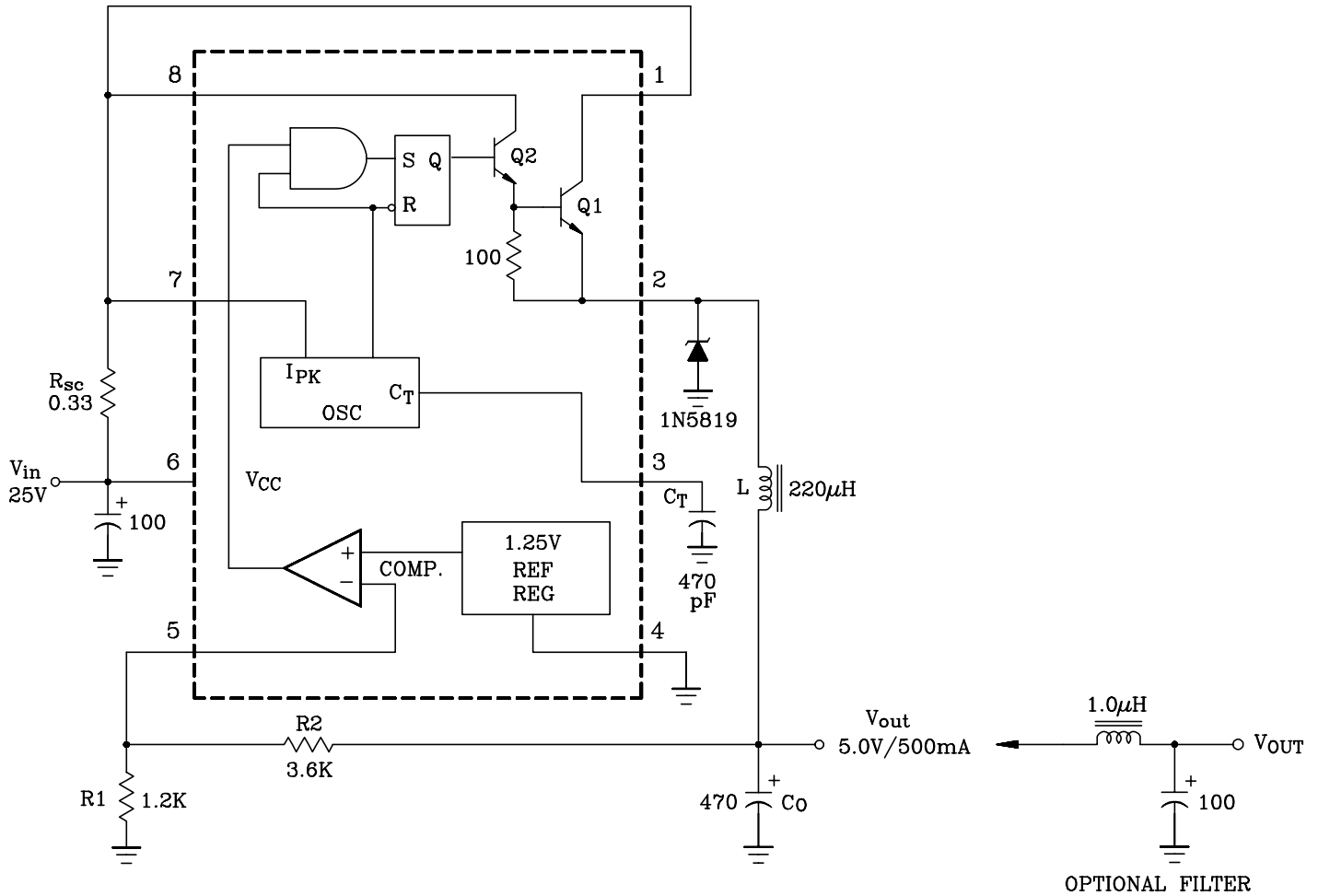

TEST	CONDITIONS	RESULTS
Line Regulation	$V_{IN}=15V$ to $25V$ , $I_O=500mA$	12mV = $\pm 0.12\%$
Load Regulation	$V_{IN}=25V$ , $I_O=50mA$ to $500mA$	3.0mV = $\pm 0.03\%$
Output Ripple	$V_{IN}=25V$ , $I_O=500mA$	120 mVpp
Short Circuit Current	$V_{IN}=25V$ , $R_L=0.1\Omega$	1.1A
Efficiency	$V_{IN}=25V$ , $I_O=500mA$	83.7%
Output Ripple With Optional Filter	$V_{IN}=25V$ , $I_O=500mA$	40 mVpp

### (3) Voltage Inverting Converter

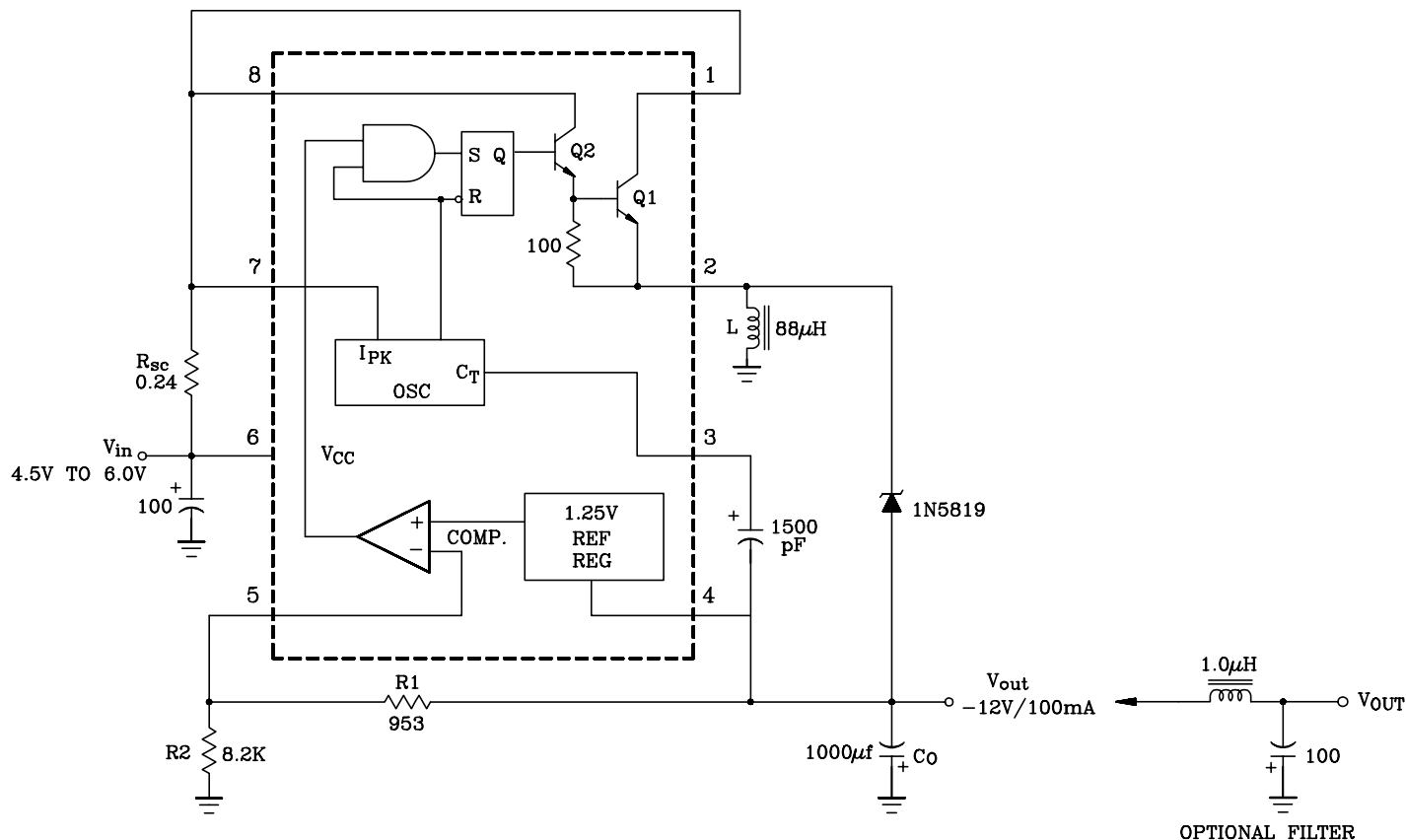

TEST	CONDITIONS	RESULTS
Line Regulation	$V_{IN}=4.5V$ to $6.0V$ , $I_O=100mA$	$3.0mV = \pm 0.012\%$
Load Regulation	$V_{IN}=5.0V$ , $I_O=10mA$ to $100mA$	$0.022V = \pm 0.09\%$
Output Ripple	$V_{IN}=5.0V$ , $I_O=100mA$	$500\text{ mV}_{pp}$
Short Circuit Current	$V_{IN}=5.0V$ , $R_L=0.1\Omega$	$910mA$
Efficiency	$V_{IN}=5.0V$ , $I_O=100mA$	$62.2\%$
Output Ripple With Optional Filter	$V_{IN}=5.0V$ , $I_O=100mA$	$70\text{ mV}_{pp}$

