

## General Description

MIC2555 is a USB On-The-Go (OTG) transceiver designed to enable intelligent self-powered devices to communicate on a peer-to-peer basis with other USB and USB OTG enabled devices. Designed to perform as a PHY for USB Serial Interface Engines (SIE), MIC2555 is compatible with a wide variety of stand-alone OTG SIE chips, OTG IP cores (used in ASIC and COT designs), and Application Specific Standard Products (ASSPs).

MIC2555 is fully compliant to USB-IF's *Universal Serial Bus Specification 2.0* and the *On-The-Go Supplement Rev 1.0a*, for Low speed and Full speed operation, and allows dual-role device (DRD) operation via an I<sup>2</sup>C based controller interface. The controller's robust register set permits full control over bus and interface activity for transacting Session Request Protocol (SRP) and Host Negotiation Protocol (HNP) sequences.

Messaging between Host and Target devices can utilize any of 2 signaling methods: USB or UART, and MIC2555 permits audio signaling on its D+, D- and ID lines in full support of analog car kit applications.

USB communication is complemented with on-chip D+, D- pull-up/pull-down resistors, an integrated charge pump and low dropout voltage regulators to provide stable internal supply voltages and to supply V<sub>BUS</sub> power when operating as an A-device. Logic input levels spanning 1.6V to 4.5V ensure compatibility with current and future generations of process technology.

The MIC2555 is offered in a space saving 4mm x 4mm 24-pin MLF™ package. Data sheets and support documentation can be found on Micrel's web site at [www.micrel.com](http://www.micrel.com).

## Features

- Complies with USB-IF USB standard 2.0 and OTG supplement Revision 1.0a.
- Provides signaling and control logic for SRP and HNP, enabling USB Dual-role device operation.
- Designed for Full-speed and Low-speed USB communications.
- I<sup>2</sup>C controller interface.
- Offers 3 modes of operation:
  - USB
  - UART
  - Audio
- Operates with V<sub>LOGIC</sub> of 1.6V – 4.5V, assuring compatibility with low voltage ASICs.
- Tri-level ID detection for recognition of USB and non-USB devices.
- Supports USB /Car Kit audio interface.
- Allows Single-ended and Differential Logic I/O.
- Integrated charge pump for V<sub>BUS</sub> supply.
- On-chip pull-up, pull-down resistors minimize external component count.
- Suspend and Power-down modes for power conservation.
- Operates over the full Industrial Temperature range: –40°C to +85°C.

## Applications

- Cellular Telephones
- PDAs
- Digital Still Cameras
- Camcorders
- Data Cradles
- CD and MP3 players
- Printers

## Ordering Information

Part Number		Address	Junction Temp. Range	Package
Standard	Pb-Free			
MIC2555BML-0	MIC2555YML-0	0x	–40°C to +85°C	24-pin MLF™
MIC2555BML-1	MIC2555YML-1	1x	–40°C to +85°C	24-pin MLF™

MicroLead Frame and MLF are trademarks of Amkor Technologies

Micrel Inc. • 2180 Fortune Drive • San Jose, CA 95131 • USA • tel +1 (408) 944-0800 • fax + 1 (408) 474-1000 • <http://www.micrel.com>

### Typical Application

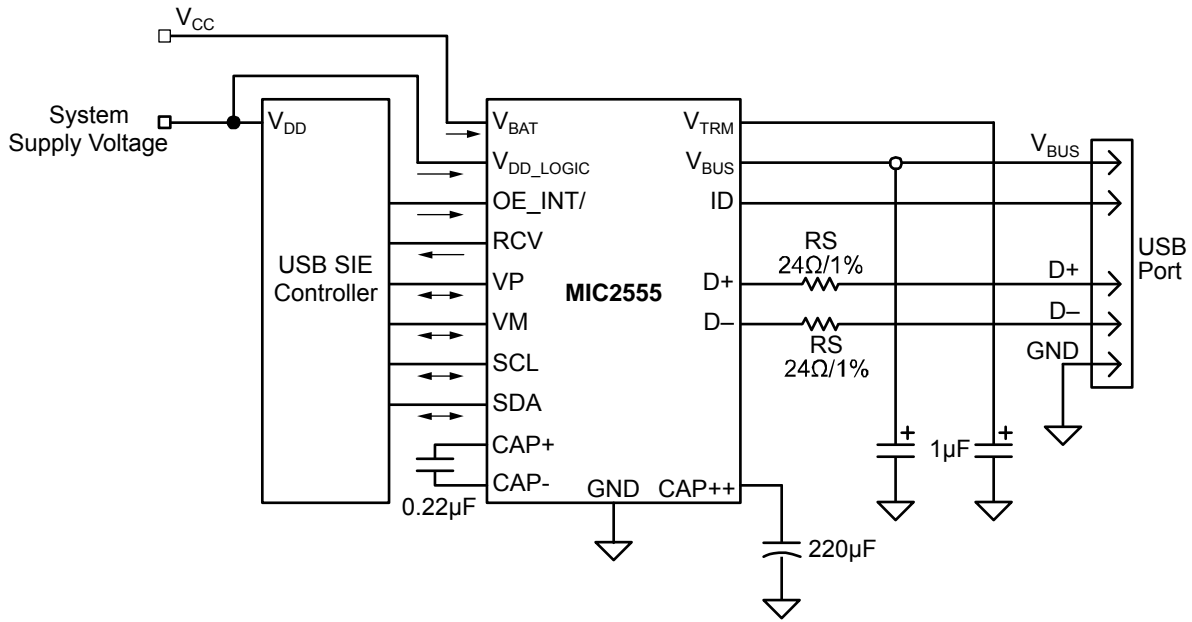

MIC2555 Typical Application Circuit

### Pin Configuration

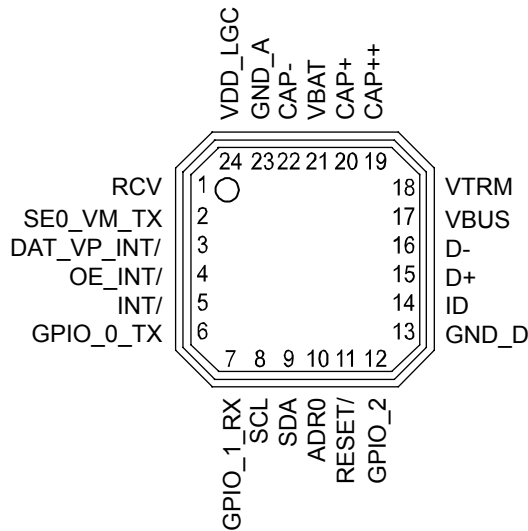

4mm x 4mm 24-pin MLF (ML)

## Pin Description

Pin Number	Type	Pin Name	Pin Description
1	O	RCV	Output from differential receiver.
2	I/O	SE0_VM_TX	= SE0 in USB DAT-SE0 mode = VM in VP-VM mode. = UART Transmit input in UART Mode
3	I/O	DAT_VP_RX	= DAT in USB DAT-SE0 mode. = VP in VP-VM mode = UART Receive input in UART mode
4	I/O	OE_INT/	A Multi-mode pin controlling various functions in conjunction with control register bits. A logic LOW on this pin gives the following results: = OE (Output Enable): Enables D+, D- as USB outputs. = INT (Interrupt): a LOW TRUE output when register bits 'suspend' and 'oe_int_en' both = 1.
5	O	INT/	Interrupt (bar). Open Drain Active LOW output. May be wire-ORed with other interrupt signals.
6	I/O	GPIO_0_RX	= General purpose I/O. = Alternate UART Receive output. Note: Connect an external UART receive input to this pin.
7	I/O	GPIO_1_TX	= General purpose I/O = Alternate UART Transmit input. Note: Connect an external UART transmit output to this pin.
8	I/O	SCL	I <sup>2</sup> C Clock
9	I/O	SDA	I <sup>2</sup> C Data
10	I	ADR_0	Sets Address bit A0 of I <sup>2</sup> C controller. This pin is a digital input and must not be left floating.
11	I	RESET/	System reset. Active LOW.
12	I/O	GPIO_2	General purpose I/O
13	I/O	GND_D	System Digital ground.
14	I/O	ID	Identification input. Monitors the ID pin of the USB connector and indicates both the presence of a device and type (USB or not USB).
15	I/O	D+	= USB D+ when in USB mode. = UART Receive in UART mode. = Right Speaker audio output in stereo mode. = Microphone signal from Car Kit.
16	I/O	D-	= USB D- when in USB mode. = UART Transmit in UART mode. = Left Speaker audio output in stereo mode. = Monaural audio output to Car Kit.
17	I/O	VBUS	USB 5V power.
18	I/O	VTRM	Internal 3.3V supply. Sets USB signal levels.
19	I	CAP++	Positive lead for charge pump reservoir capacitor.
20	I	CAP+	Positive lead for charge pump capacitor.
21	I	VBAT	Positive voltage from battery. Supplies power to MIC2555 internal circuitry and power for charge pump when driving VBUS.
22	I	CAP-	Negative lead for charge pump capacitor.
23	I	GND_A	Analog ground. Isolated Charge Pump ground.
24	I	VDD_LGC	Logic supply voltage. Used to set logic levels between MIC2555 and System Controller / ASIC.

**Absolute Maximum Ratings<sup>(1)</sup>**

## Power Supply Voltage:

 $V_{BAT, GPIO}$  ..... 0.3 V to +6.0 V $V_{DD\_LGC}$  ..... -0.3 V to +6.0 V and  $< V_{BAT}$ 

## USB Bus Voltage

 $V_{BUS}$  ..... -0.3 V to +6.0 V $V_{DD\_LGC}$  ..... -0.3 V to +6.0 V and  $\leq V_{BUS}$ 

Voltage On Any Other Pin ..... -0.3 V to +4.5 V

Current Into/Out of Any Pin .....  $\pm 10$  mA

Junction Temperature ..... 150°C

Storage Temperature ..... -65°C to +150°C

ESD Ratings:.....  $V_{BUS}$ , D+, D-, ID

Human Body Model ..... 15 kV

ESD Ratings:..... All other pins

Human Body Model ..... 2 kV

**Operating Ratings<sup>(2)</sup>**

## Power Supply Voltage:

 $V_{BUS}$  ..... 3.0V to 5.25V $V_{BAT}$  ..... 3.0V to 4.5V

Operating Temperature ..... -40°C to +85°C

Package Thermal Resistance ..... 49°C/W

**Electrical Characteristics<sup>(3)</sup>**Test condition is 25°C unless otherwise specified. **Bold** indicates -40°C + 85°C. $V_{BAT} = 3.6V$ ,  $V_{DD\_LGC} = 3.6V$ ,  $V_{BUS} = 5.0V$ ,  $V_{TRM} = 1\mu F$ ,  $C_+ = 0.22\mu F$ ,  $C_{++} = 220\mu F$ ,  $C_{VBUS} = 10\mu F$ 

Symbol	Parameter	Condition	Min	Typ	Max	Units
<b>Power Supplies</b>						
$V_{BAT}$	System Supply Voltage		<b>3.0</b>		<b>4.5</b>	V
$V_{DD\_LGC}$	Logic Supply Voltage		<b>1.6</b>		$V_{BAT}$	V
$V_{TRM}$	Termination Voltage (internal supply voltage)	$I_{TRM} \leq 2.5mA$ , $3.0 < V_{BAT} < 3.6V$	<b>2.8</b>	3.3	<b>3.6</b>	V
$I_{BAT\_PD}$	System Supply Current	Power Down mode		13	<b>20</b>	$\mu A$
$I_{BAT\_SUS}$	System Supply Current	Suspend mode		140	<b>250</b>	$\mu A$
$I_{BAT\_FS\_I}$	System Supply Current	Full Speed, Idle, $D+ \geq 2.8V$ , $D- \leq 0.3V$ , $I_{VBUS} = 0mA$		2.8	<b>5.0</b>	mA
$I_{BAT\_FS\_HC}$	System Supply Current	Full Speed Transmitting 12Mb/s, $C_{LOAD} \leq 350pF$ on D+, D-, $I_{VBUS} = 0mA$		17	<b>40</b>	mA
$I_{BAT\_FS\_LC}$	System Supply Current	Full Speed Transmitting 12Mb/s, $C_L = 50pF$ on D+, D-, $I_{VBUS} = 0mA$		2.5	<b>6</b>	mA
$I_{BAT\_LS\_HC}$	System Supply Current	Low Speed Transmitting 1.5Mb/s, $C_L = 350pF$ on D+, D-, $I_{VBUS} = 0mA$		6.5	<b>12</b>	mA
$I_{VBUS\_S}$	Current drawn by System from $V_{BUS}$	Suspend mode, $OE\_INT/ = 1$		80	<b>100</b>	$\mu A$
$I_{VDD\_LGC}$	Current drawn by System for core logic	$OE\_INT/ = 1$		7	<b>15</b>	$\mu A$
<b>Charge Pump and <math>V_{BUS}</math></b>						
$V_{BUS\_OUT}$	Voltage Output to $V_{BUS}$	$I_{BUS} = 10mA$ , $V_{BAT} = 3.0V$	<b>4.4</b>	5.0	<b>5.25</b>	V
$I_{VBUS}$	$V_{BUS}$ Output Current	$4.4V \leq V_{BUS} \leq 5.25V$	<b>10</b>	27		mA
$R_{VBUS\_PU}$	B device SRP Pull-up Resistor on $V_{BUS}$	Pull-up voltage = $V_{TRM}$	<b>281</b>	1300	<b>7500</b>	$\Omega$
$R_{VBUS\_PD}$	B device SRP Pull-down Resistor on $V_{BUS}$	Pull-down to GND	675	2300	<b>7500</b>	$\Omega$

Symbol	Parameter	Condition	Min	Typ	Max	Units
R <sub>A_BUS_IN</sub>	V <sub>BUS</sub> Input Resistance	Seen from V <sub>BUS</sub> pin to GND	<b>40</b>	63	<b>100</b>	kΩ
V <sub>TH_VBUS</sub>	'V <sub>BUS</sub> Valid' Comparator Threshold Voltage		<b>4.4</b>	4.5	<b>4.6</b>	V
V <sub>TH_SV</sub>	'Session Valid' Comparator Threshold Voltage		<b>0.8</b>	1.4	<b>2.0</b>	V
V <sub>TH_SE</sub>	'Session End' Comparator Threshold Voltage		<b>0.2</b>	0.4	<b>0.8</b>	V
<b>ID</b>						
V <sub>THH_R_ID</sub>	Upper Threshold for ID Resistor Sensing	V <sub>BAT</sub> = 3.0V	<b>2.45</b>	2.55	<b>2.65</b>	V
V <sub>THL_R_ID</sub>	Lower Threshold for ID Resistor Sensing	V <sub>BAT</sub> = 3.0V	<b>0.35</b>	0.42	<b>0.55</b>	V
R <sub>ID_PU</sub>	Pull-up Resistor switched to ID for detecting non-USB devices		70	90	130	kΩ
I <sub>ID_WPU</sub>	Weak Pull-up current source driving ID pin	V <sub>ID</sub> = 0V	<b>2</b>		<b>6</b>	μA
R <sub>ID_SW_GND</sub>	Interrupt Pulse Switch	V <sub>ID</sub> ≤ 200mV		1.0	<b>4.0</b>	kΩ
<b>Logic Levels</b> - SDA, SCL, ADR0, OE_INT/, SE0_VM_TX, DAT_VP_RX, RCV, INT, RESET/ & GPIO						
V <sub>IL</sub>	LOW-Level Input Voltage	SDA, SCL			<b>0.3x</b> V <sub>DD_LGC</sub>	V
V <sub>IH</sub>	HIGH-Level Input Voltage		<b>0.7x</b> V <sub>DD_LGC</sub>			V
	Input Hysteresis		<b>100</b>			mV
V <sub>IL</sub>	LOW-Level Input Voltage	ADR0, OE_INT/, SE0_VM_TX, DAT_VP_RX, RCV, INT, RESET/ & GPIO Applies to USB and UART modes.			<b>0.15x</b> V <sub>DD_LGC</sub>	V
V <sub>IH</sub>	HIGH-Level Input Voltage		<b>0.85x</b> V <sub>DD_LGC</sub>			V
I <sub>IN_LGC</sub>	Input Leakage Current	1.6V ≤ V <sub>DD_LGC</sub> ≤ 4.5V	<b>-5</b>		<b>+5</b>	μA
V <sub>OL</sub>	LOW-Level Output Voltage	I <sub>OL</sub> = 100μA		.02	<b>0.1</b>	V
V <sub>OH</sub>	HIGH-Level Output Voltage	I <sub>OH</sub> = 100μA	<b>0.9x</b> V <sub>DD_LGC</sub>			V
V <sub>OL_SDA</sub>	LOW-Level Output Voltage at SDA pin	I <sub>OL</sub> = 5mA			<b>0.3x</b> V <sub>DD_LGC</sub>	V
V <sub>OH_SDA</sub>	HIGH-Level Output Voltage at SDA pin	R <sub>SDA_PU</sub> = 3.0K	<b>0.7x</b> V <sub>DD_LGC</sub>			V
V <sub>OL_GPIO</sub>	LOW-Level Output Voltage at GPIO pins	I <sub>OL</sub> = 10mA		150	<b>250</b>	mV
V <sub>OH_GPIO</sub>	HIGH-Level Output Voltage at GPIO pins	R <sub>PU</sub> = 3.0K		V <sub>DD_PU</sub> - 0.1V	V <sub>DD_PU</sub>	V
I <sub>OH_GPIO</sub>	GPIO Output driver leakage current	V <sub>DD_PU</sub> = V <sub>OH_GPIO</sub> = 5V		1	<b>30</b>	μA

Symbol	Parameter	Condition	Min	Typ	Max	Units	
<b>Transceiver DC Characteristics - D+, D-</b>							
V <sub>DI</sub>	Differential Input Sensitivity	$(D+) - (D-)$  , V <sub>IN</sub> = 0.8V – 2.5V	<b>0.2</b>			V	
V <sub>CM</sub>	Differential Common-Mode Range	Includes V <sub>DI</sub> Range	<b>0.8</b>		<b>2.5</b>	V	
V <sub>TH_SE</sub>	Single-Ended Receiver Threshold		<b>0.8</b>	1.5	<b>2.0</b>	V	
V <sub>HYS</sub>	Receiver Hysteresis	D+, D-		200		mV	
V <sub>OL</sub>	LOW-Level Output Voltage	OE_INT/ = 0, R <sub>L</sub> = 1.5kΩ to 3.6V		0.1	<b>0.3</b>	V	
V <sub>OH</sub>	HIGH-Level Output Voltage	OE_INT/ = 0, I <sub>SOURCE</sub> = 1mA	<b>2.8</b>	3.3	<b>3.6</b>	V	
R <sub>DRV</sub>	Transceiver Output Resistance	D+, D-	<b>5</b>	12	<b>24</b>	Ω	
R <sub>PU_D</sub>	Internal Pull-Up Resistor on D+ and D-	V <sub>TRM</sub> to D+ or D-	Active	<b>1.425</b>	2.25	<b>3.09</b>	kΩ
			Idle	<b>0.900</b>	1.24	<b>1.575</b>	kΩ
R <sub>PD_D</sub>	Internal Pull-Down Resistor on D+ and D-	D+ to GND, D- to GND	14.3	19.5	24.8	kΩ	
C <sub>IN_D</sub>	Transceiver Input Capacitance	D+, D- pins to GND See Note 4			20	pF	
V <sub>THL_INT_HI</sub>	Interrupt Detector Threshold HIGH		<b>2.5</b>	3.0	<b>3.3</b>	V	
V <sub>THL_INT_LO</sub>	Interrupt Detector Threshold LOW		<b>0.3</b>	0.5	<b>0.7</b>	V	
<b>Transceiver AC Characteristics - D+, D-</b>							
V <sub>C2C</sub>	Channel-to-Channel Isolation between D+, D- and ID pins (in audio mode)	DC bias (pin to GND) = 0.4V AC signal = 600mVp-p Freq. = 2kHz See Note 4	-60			dB	
Z <sub>OUT_3S_D</sub>	High-Z State Output Impedance	0V < V <sub>D</sub> < 3.6V, f = 2kHz OE_INT/ = 1 Measured at D+, D- pins, with respect to GND See Note 4	300			kΩ	
<b>Data Rate</b>							
F <sub>I2C</sub>	I <sup>2</sup> C signaling rate	V <sub>BAT</sub> = 3.6V	<b>100</b>	400		kbps	
		V <sub>BAT</sub> = 3.0V	<b>100</b>	200		kbps	
<b>Driver Characteristics - Full Speed</b> T <sub>AMB</sub> = 25°C							
t <sub>R_FS</sub> t <sub>F_FS</sub>	Transition Time: Rise Time Fall Time	C <sub>L</sub> = 50pF to 125pF	4	12.5	20	ns	
		See Note 4	4	12.5	20	ns	
t <sub>R</sub> / t <sub>F</sub>	Rise/Fall Time Matching	(T <sub>R</sub> / T <sub>F</sub> )	90		111.11	%	
V <sub>CRS</sub>	Output Signal Crossover Voltage		1.3		2.0	V	
t <sub>PLH</sub> t <sub>PHL</sub>	Propagation delay	LOW to HIGH			18	ns	
		HIGH to LOW See Note 4			18	ns	

Symbol	Parameter	Condition	Min	Typ	Max	Units
T <sub>PDZ</sub>	Driver Disable to Tri-State delay (Full or Low Speed)	HIGH to OFF			15	ns
		LOW to OFF See Note 4			15	ns
T <sub>PZD</sub>	Driver Tri-State to Enable delay (Full or Low Speed)	OFF to HIGH			15	ns
		OFF to LOW See Note 4			15	ns
<b>Driver Characteristics - Low Speed</b> T <sub>AMB</sub> = 25°C						
t <sub>R_LS</sub> t <sub>F_LS</sub>	Transition Time: Rise Time Fall Time	C <sub>L</sub> = 350pF	75	245	300	ns
		See Note 4	75	265	300	ns
t <sub>R</sub> / t <sub>F</sub>	Rise/Fall Time Matching	(T <sub>R</sub> / T <sub>F</sub> )	80		125	%
V <sub>CRS</sub>	Output Signal Crossover Voltage		1.3		2.0	V
<b>Receiver Characteristics - Full Speed / Low Speed</b>						
<b>Differential Receiver</b>						
t <sub>P_LH</sub> t <sub>P_HL</sub>	Propagation delay	LOW to HIGH			15	ns
		HIGH to LOW See Note 4			15	ns
<b>Single-Ended Receivers</b>						
t <sub>P_LH</sub> t <sub>P_HL</sub>	Propagation delay	LOW to HIGH			18	ns
		HIGH to LOW See Note 4			18	ns
<b>ESD<sup>(3)</sup></b>						
V <sub>ESD</sub>	Electro Static Discharge Voltage	D+, D-, ID, and VBUS to GND Human Body Model	±15			kV
V <sub>ESD</sub>	Electro Static Discharge Voltage	All pins Human Body Model	±2			kV

## Notes:

1. Exceeding the absolute maximum rating may damage the device.
2. The device is not guaranteed to function outside its operating range.
3. Specifications are for packaged product only.
4. Parameters are guaranteed by design. They are not production tested.

# Functional Diagram

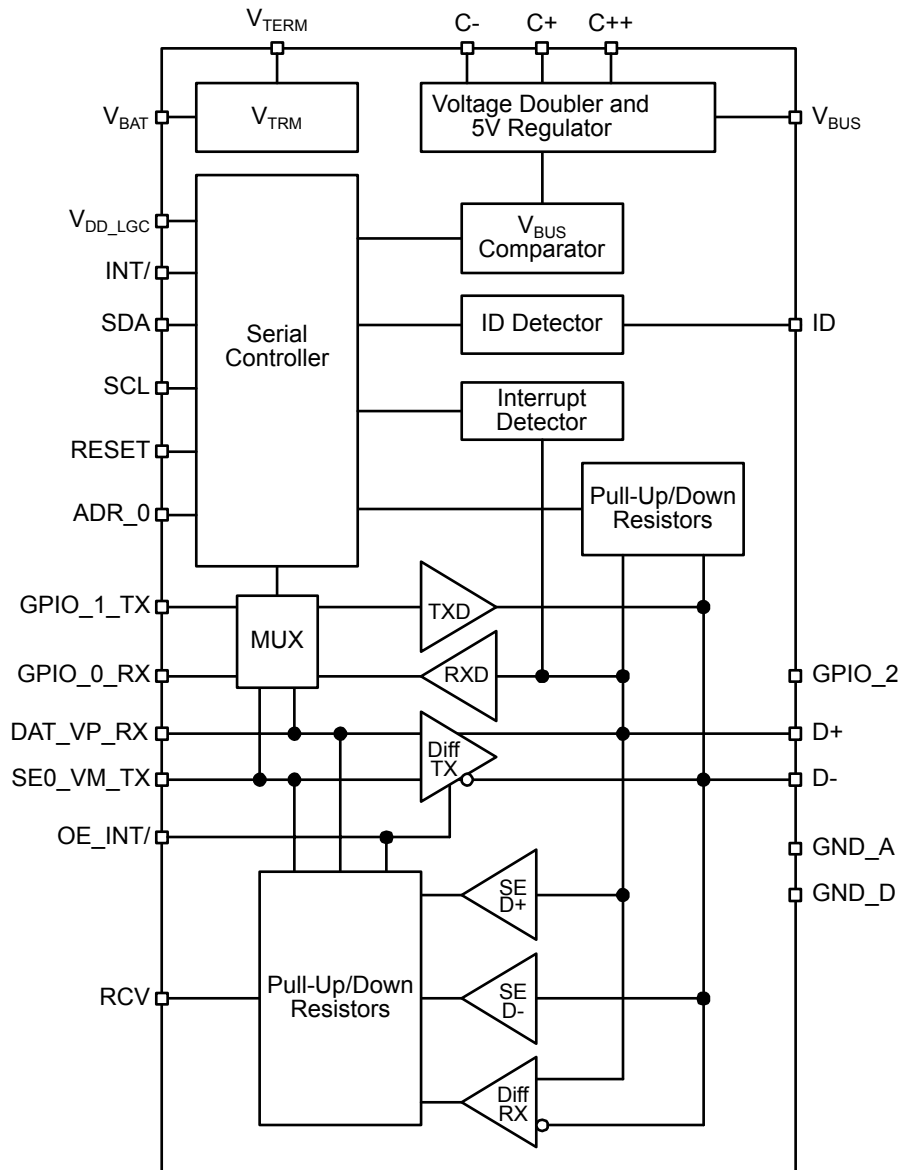

**MIC2555 Block Diagram**



## Functional Description

The MIC2555 is designed to provide full USB On-The-Go (OTG) connectivity in mobile systems where low power and small size are key considerations. Intended for use in self-powered systems, the MIC2555 draws no current from  $V_{BUS}$  for its operation, but will supply a minimum of 8 mA at 5V to  $V_{BUS}$ , from an on-chip charge pump, when operating as an A-device. The MIC2555 meets USB physical layer specifications while operating with logic supply voltages as low as 1.6V and battery voltages down to 3.0V.

MIC2555 operation is controlled by an  $I^2C$  bus by reading and/or writing to registers within the MIC2555. Control registers are used to set the operational mode to USB, Audio or UART ('RS232' format). Other features include  $V_{BUS}$  comparators for SRP detection and ID pin recognition of USB and non-USB peripherals.

The MIC2555 minimizes collateral components, requiring only 4 external capacitors and two resistors. All USB required pull-up/pull-down resistors are on-chip. 15KV ESD protection on all pins exposed to user contact ( $V_{BUS}$ , D+, D-, ID and GND) eliminates the need for external ESD transient protection devices.

An 'OTG Controller' is understood to be any integrated circuit, or system, possessing a built-in USB OTG Host/Device control function but lacking the USB physical layer interface.

### Definitions and Conventions

Car Kit	=	A non-USB target device
$I^2C$	=	Inter IC Bus ( $I^2C$ )
NUT	=	non-USB target device
OTG <sup>(1)</sup>	=	On-The-Go
SIE	=	Serial Interface Engine
SE0	=	Single Ended Zero
SRP	=	Session Request Protocol
USB	=	Universal Serial Bus
USB-IF	=	USB Implementers Forum
Serial Controller	=	Means the $I^2C$ control function within MIC2555.

#### Notes:

1. An 'OTG Controller' is understood to be any integrated circuit, or system, possessing a built-in USB OTG Host/Device control function but lacking the USB physical layer interface.
2. UPPER CASE names are IC pins. Examples: **RCV**,  $V_{BUS}$  or **OE\_INT**
3. Lower case names are control register bits. Examples: **dat\_se0**.

## System Description

### Overview:

The MIC2555 OTG Transceiver provides the physical interface for ASICs, uPs and SOCs having an On-The-Go Serial Interface Engine (SIE) but lacking a physical interface capable of driving cables, or generating and detecting the necessary voltages to operate as a USB host.

MIC2555 goes beyond the confines of the USB OTG standard and provides flexible communication between many kinds of digital devices. Point-to-point UART and Audio communications can also be accomplished using the MIC2555 and any and all of these formats can be utilized by a single system.

All communications are accomplished via the D+ and D-I/O pins. The information passed through D+ and D- depends upon the mode of communication determined by system control through the MIC2555's control registers.

### Modes of Operation

The MIC2555 OTG Transceiver has five distinct operating modes:

- **USB mode:** Operates as a USB OTG transceiver.
- **UART mode:** Operates as a UART transceiver
- **Audio mode:** Operates as a passive device in within the audio path, but actively monitoring for digital control signals.

### USB mode

The two modes of USB operation involve the way data is transferred between the SIE and the transceiver. These modes are:

- **DAT-SE0 mode:**
  - DAT\_VP\_RX → .DAT: single ended data I/O
  - SE0\_VM\_TX → SEO: detects or sends the SE0 condition.
  - RCV is not used
- **VP-VM mode:**
  - DAT\_VP\_RX → VP: D+ data to transceiver output.
  - SE0\_VM\_TX → VM: D- data to transceiver output.
  - RCV → Output of the differential receiver.

#### Data flow direction:

Transmit → OT\_TP\_INT/ = 0  
Receive → OT\_TP\_INT/ = 1

#### Conditions for USB mode:

uart\_en = 0  
Speed = Low speed = 0  
Full speed = 1

**UART mode**

There are two UART modes of operation:

- **Direct UART:**
  - UART TX → SE0\_VM\_TX pin, data is output on D
  - UART RX ← DAT\_VP\_RX pin receives UART data from D+.
- **Secondary UART:**
  - UART TX → GPIO\_1\_TX pin, data is output on D
  - UART RX ← GPOI\_0\_RX pin, received from D+.

Conditions for UART mode:

```
uart_en = 1
speed = 1
uart_io = Direct UART = 0
          Secondary UART inputs (GPIO) = 1
```

Note:  
It is not necessary to reset `uart_io` when switching from UART to USB mode; `uart_io` is deactivated when `uart_en = 0`, so its setting will not effect `DAT_VP_RX` or `SE0_VM_TX`'s operation in USB mode.

**Audio Mode**

There is one mode of Audio operation. In audio mode, the MIC2555's D+ and D- outputs are Tri-Stated (high impedance) and the OTG controller or system components can send and receive audio signals via the D+, D- lines. The MIC2555 will monitor the D+ line for voltages crossing one of two levels, as a means of detecting a car kit interrupt signal. These interrupt events are captured and flagged by the Serial Controller.

Conditions:

```
uart_en = 0
OE_INT/ = 1
cr_int_sel = detect @ 3.0V = 0
             detect @ 0.5V = 1
```

Note:

The MIC2555 has no provision to connect or disconnect audio devices from the D+, D- lines, so the designer is cautioned to be sure that when the MIC2555 is operating as a data transceiver, no damage will ensue if the system's audio components are exposed to USB or UART digital signal levels.

**Power Management**

The transceiver's power modes are:

**Active power:**

All functions active, transceiver fully powered.

Conditions:

```
suspend = 0
pwr_dn = 0
```

**Suspend power:**

The differential transmitter and receiver are turned off to conserve power but the USB interface is still active (i.e., pull-ups and pull-downs still active,  $V_{BUS}$  generation on, etc.).

Conditions:

```
suspend = 1
pwr_dn = 0
```

**Power Down:**

Only the serial interface is still active and the transceiver is able to detect SRP. The ID pin sensing may be turned on or off with a control bit in the control registers.

Conditions:

```
suspend = 1
pwr_dn = 1
```

Functions Powered Down By Control Bit	Control Bit		
	suspend	pwr_dn	cp_off
Differential Driver	●		
Differential Receiver	●		
UART TXD	●		
D+ interrupt comparators	●		
$V_{BUS}$ Comparators		●	
$V_{TRM}$ LDO		●	
$V_{BUS}$ output		●	
Internal biasing circuits and band gap reference		●	
Charge Pump off		●	●

**Power Management Table**

Note: Suspend and Power-Down bits operate independently of each other. Activating Power-Down does not automatically invoke Suspend.

For lowest power operation Suspend, Power-Down and Charge Pump OFF modes must be activated:

Conditions:

- suspend = 1
- pwr\_dn = 1
- cp\_off = 1

Circuits still operating:

ID detect (ID comparators and ID pull-up circuitry) D-data receiver (system can still receive digital data from D- line).

**Serial Controller Block**

The Serial Controller manages MIC2555 operations. Turning ON/OFF features, changing operating modes, setting and selecting interrupts are all handled by the Serial Controller. MIC2555's Serial Controller communicates with the OTG Controller as an I<sup>2</sup>C slave using the SCL and SDA pins.

The Serial Controller includes the following functions:

- Control registers
- Status registers
- Interrupt latches
- Interrupt enable registers
- Interrupt clear registers
- Interrupt generator

**VBUS Charge Pump and 5V regulator**

The charge pump draws power from V<sub>BAT</sub> and boosts the voltage to the requisite 5V to power V<sub>BUS</sub>. This subsystem is actually a combination of a charge pump circuit and a control loop that gates the charge pump's oscillator. If the output voltage is below 5V, then the oscillator is ON; otherwise, the oscillator is gated OFF. The charge pump's maximum output is controlled by the magnitude of V<sub>BAT</sub>. When V<sub>BAT</sub> is at 3.0V, the charge pump is designed to support loads of at least 8 mA on V<sub>BUS</sub>. As V<sub>BAT</sub> increases, output current also increases. For proper operation the charge pump circuit requires 2 capacitors; one for the voltage doubler, connected between C- and C+, and a reservoir/filter capacitor between C++ and ground. The charge pump's nominal operating frequency is 200 kHz, which is set by an on-chip oscillator. A special feature of MIC2555 is that an external oscillator can drive the charge pump as well, allowing the designer to shift radiated noise away from sensitive frequencies when necessary. Also, when 5V power is not required from V<sub>BUS</sub>, the charge pump can be shut down to conserve power.

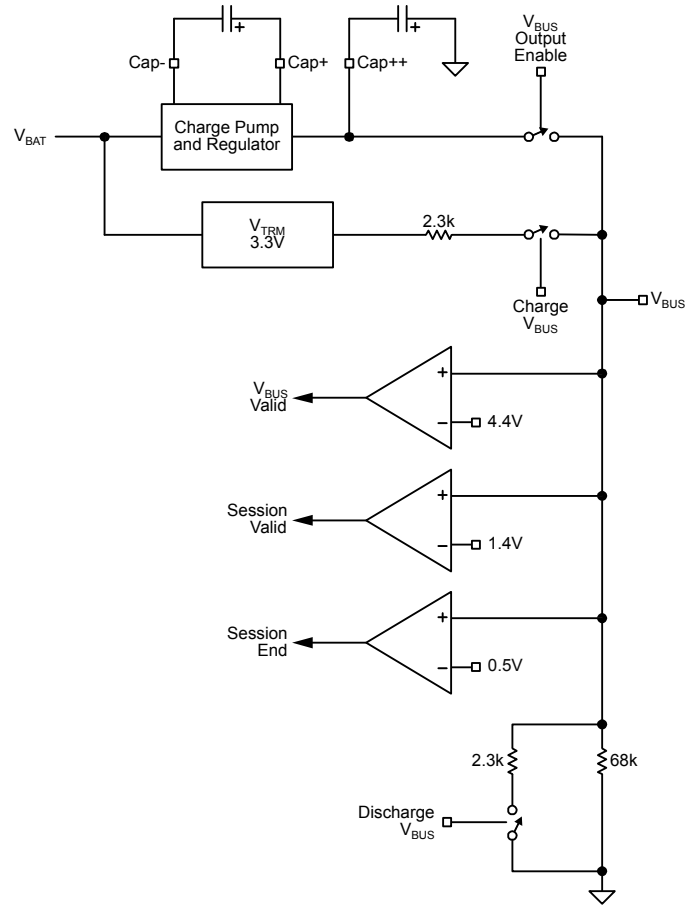

**VBUS Circuitry**

**VBUS Resistors and Switches**

MIC2555 is able to:

- charge up V<sub>BUS</sub> through a resistor
- initiate SRP
- pull down V<sub>BUS</sub> through a resistor to ground
- discharge V<sub>BUS</sub> before initiating SRP
- switch V<sub>BUS</sub> power from the charge pump ON/OFF

Dedicated bits in the control registers operate all of these functions. Because these bits act independently, it is possible to have V<sub>BUS</sub> both charging and discharging at the same time. This situation will not harm the MIC2555, but will instead not produce a useful result.

To prevent system leakage currents from biasing V<sub>BUS</sub> to a voltage that would mimic a session valid condition, the MIC2555 maintains a high value resistor of between V<sub>BUS</sub> and ground to insure that at no time will V<sub>BUS</sub> assume a floating condition.

**VBUS Comparators**

V<sub>BUS</sub> Comparators monitor the voltage level of V<sub>BUS</sub>. As described in the USB On-The-Go Supplement, V<sub>BUS</sub> not only supplies power but also is used to signal various operational conditions as part of the SRP protocol. Depending upon the voltage on V<sub>BUS</sub>, three states of operation can be defined:

- V<sub>BUS</sub> Valid
- Session Valid
- Session End.

**VBUS Valid Comparator**

This comparator is used by an A-device to determine whether the voltage on V<sub>BUS</sub> is at a valid level for operation. The minimum threshold for the V<sub>BUS</sub> valid comparator is 4.4V. Any voltage on V<sub>BUS</sub> below the threshold of the V<sub>BUS</sub> valid comparator is considered a fault. During power up, it is expected that this comparator's output will be ignored.

**Session Valid Comparator**

The session valid comparator determines when V<sub>BUS</sub> is high enough for a session to start. Both the A-device and B-device use this comparator to detect when a session is being started. The A-device also uses this comparator to indicate when a session is over.

The session valid window for an A-device is 0.8 – 2.0V while the session valid window for a B-device is 0.8 – 4.0V. Because these ranges overlap the A-device window is typically chosen to service both requirements and a single comparator can be used. This is the case with MIC2555.

**Session End Comparator**

The USB OTG Supplement specifies that a B-device cannot initiate SRP unless V<sub>BUS</sub> is below the B-device Session End threshold of 0.8V. Monitoring V<sub>BUS</sub> with a comparator will give an exact and positive determination of when V<sub>BUS</sub> has dropped below 0.8V, but the USB OTG supplement allows that the 0.8V limit can also be inferred, by discharging V<sub>BUS</sub> through a low value resistor for a predetermined period. The MIC2555 provides both a session-end comparator and a discharging resistor. To accommodate either technique, the designer can use them individually or, in concert as he so chooses.

**Pull-up/down Resistors on D+, D-**

MIC2555 supplies the pull-up and pull-down resistors for termination and signaling required by USB specifications. These resistors are integrated within the chip and switched into the circuit, as needed, via individual control bits in the control registers.

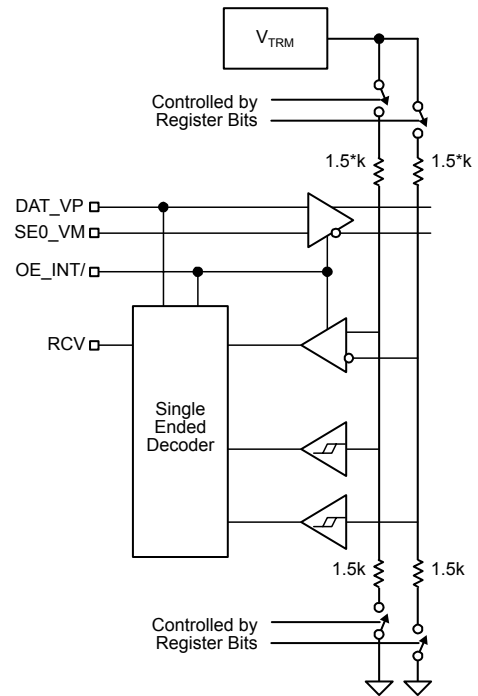

**Resistors and Circuitry associated with D+, D- Pins**

**ID Detector**

The ID function, defined within the USB On-The-Go supplement, represents a new addition to the USB standard. It is used to detect the presence or removal of a peripheral device as well as to differentiate between USB and non-USB peripherals. ID is unique to the mini-USB connectors and receptacles.

MIC2555's ID Detector is operational in both the Active and Suspended power modes, and differentiates between three conditions:

ID Pin Condition	Device Status	V <sub>ID</sub>
Floating	No device present	V <sub>ID</sub> > 0.85V <sub>BAT</sub>
Grounded	USB device present	0.15V <sub>BAT</sub> < V <sub>ID</sub> < 0.85V <sub>BAT</sub>
Grounded through a Resistor	Non-USB device present	V <sub>ID</sub> < 0.15V <sub>BAT</sub>

Here, 'Grounded through a Resistor' means a resistor of a considerable value, typically 100kΩ. The ID comparators are set to ignore the modest resistances contributed by the cables and connector contacts.

That a non-USB device is present (ID = resistive) is inferred from the interrupt register by the indication of an interrupt (ID has changed state) and that neither ID = GND or ID = Float are true. Viewing the Interrupt source register will give the real time status of the ID comparator outputs. Viewing this register is necessary to determine the true state of affairs as insertion of the USB

plug can produce multiple rail-to-rail transitions. These will trigger both comparators and produce a conflicting result: ID = GND and ID = Float.

After the nature of the newly connected device has been determined, activating a current source in series with the internal ID pull-up resistor can reduce power consumption caused by ID sensing. This is accomplished by clearing `rsc_dis` in Control Register 3.

When the connected device is removed, and the ID pin is pulled HIGH by the current source (ID=GND is no longer true), MIC2555 automatically resets `rsc_dis`, disabling the current source.

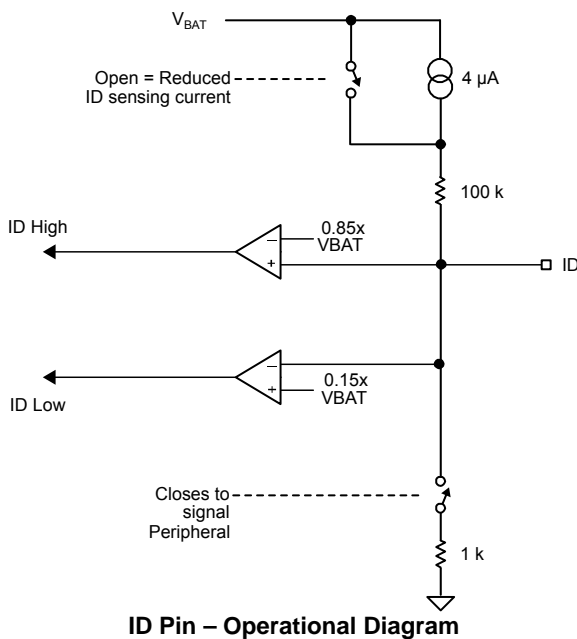

**Interrupt Detector**

When in Audio mode, the MIC2555 does not participate in the audio transmissions, but monitors the D+ line for interrupt pulses. If the Serial Controller is configured to flag interrupt pulses, the system controller can exchange both audio signals and digital information with the target device.

MIC2555 is designed to detect two different interrupt pulses, those exceeding 3.0V and those crossing the 0.5V level. Under normal circumstances, the audio signal seen on D+ is transposed on a DC level and limited to voltage excursions between the 0.5V and 3.0V levels, so only interrupt pulses should cross these thresholds. Signaling is typically done with only one polarity pulse so MIC2555 is designed to monitor only one threshold at a time. Threshold selection is done with the `cr_int_sel` bit, and the interrupt (`cr_int`) can be set to trigger on pulses of either polarity.

**UART Mux**

System controllers with UART communication ability may or may not be able to route their UART signals through the VP, VM or DAT, SE0 pins. For those with independent UART connectivity, MIC2555 provides a secondary UART I/O port. The MUX, under direction of the Serial Controller, selects which UART I/O is used by the OTG controller.

Condition:

- `uart_io = 0` SE0\_VM\_TX = transmit  
DAT\_VM\_RX = receive
- `uart_io = 1` GPIO\_1\_TX = transmit  
GPIO\_0\_RX = receive

**Differential Driver / Differential Receiver**

Operation of the Differential Driver and Differential Receiver is described in the tables below and on the following page. The register bits used in the column headings are described in the Serial Controller section of this data sheet.

**VTRM**

$V_{BAT}$  powers  $V_{TRM}$ , which supplies 3.3V power to the differential USB transmitter and the UART drivers and receivers. As  $V_{BAT}$  drops below 3.4V,  $V_{TRM}$  is no longer able to regulate and follows  $V_{BAT}$  at about 0.1V less than  $V_{BAT}$ . When this occurs, output drive levels for USB and UART are reduced accordingly.

**USB mode:** `uart_en = 0`

suspend	dat_se0	OE_INT/	RCV	DAT_VP	SE0_VM	D+	D-
0	0	0	DIFF	TX data	TX data	DAT_VP	SE0_VM
0	0	1	DIFF	SE_DP	SE_DM	RX data	RX data
0	1	0	Z	TX data	TX data	TX_DAT	TX_SE0
0	1	1	Z	DIFF	RX_SE0	RX data	RX data
1	0	1	Z	SE_DP	SE_DM	RX data	RX data
1	1	1	Z	SE_DP	RX_SE0	RX data	RX data

DIFF = Differential receiver output  
 RX\_SE0 = not (SE\_DP) and not (SE\_DM)  
 TX\_DAT = DAT\_VP and not (SE0\_VM)  
 TX\_SE0 = not (DAT\_VP) and not (SE0\_VM)  
 Z = Tri-State

**UART mode:** `uart_en = 1`

suspend	dat_se0	OE_INT/	RCV	DAT_VP	SE0_VM	D+	D-
0	x	x	Z	SE_DP	TX data	RX data	SE0_VM
1	x	x	Z	Z	Z	Z	Z

Z = Tri-State

### Single-Ended Receivers

The Single Ended Receivers detect the logic levels on the D+ and D- lines, and provide this information to the Single Ended Decoder.

### Single-Ended Decoder

Behavior of the Single-Ended Decoder is dependent upon the power mode of the transceiver. If transceiver is in the Suspend power mode, and `dat_se0 = 1` (DAT-SE0 mode), then the DAT\_VP\_RX pin will reflect the output of the D+ single ended receiver. This is necessary so that a controller connected to the transceiver can detect data pulsing while the transceiver is in suspend mode.

## Pin Descriptions

### VBAT

This pin is an input, and supplies power to the transceiver. Transceiver typical operational voltages are between  $3.0\text{V} \leq V_{\text{BAT}} \leq 4.5\text{V}$  and  $1.6\text{V} \leq V_{\text{DD\_LGC}} \leq V_{\text{BAT}}$ .

### VDD\_LGC

This input is used to set the logic thresholds of the following logic signals:

- DAT\_VP\_RX
- SE0\_VM\_TX
- RCV
- OE\_INT/
- INT/
- ADR0
- RESET/
- GPIO

Note:

$V_{\text{DD\_LGC}}$  can be at a voltage less than or equal to  $V_{\text{BAT}}$ , but *never* higher than  $V_{\text{BAT}}$ . Doing so will forward bias internal pad protection diodes and current will flow from  $V_{\text{DD\_LGC}}$  to  $V_{\text{BAT}}$ . For this reason, systems should not allow  $V_{\text{BAT}}$  to go to zero while  $V_{\text{DD\_LGC}}$  remains powered. This condition may damage the MIC2555, and could put a severe load on  $V_{\text{DD\_LGC}}$  as it attempts to power the MIC2555 and all other circuits

attached to the  $V_{\text{BAT}}$  line.

### VBUS

This pin functions as both an input to, and output from, the transceiver. Unlike standard USB transceivers, however, the MIC2555 always derives its operating power from  $V_{\text{BAT}}$  and never from  $V_{\text{BUS}}$ . The MIC2555 will supply power to  $V_{\text{BUS}}$  when acting as a host device and when petitioning another OTG, capable device to become the host. To do so the `vbus_chrg` bit is asserted. To power  $V_{\text{BUS}}$ , as a host device, the `vbus_drv` bit is asserted. The difference between these two controls is `vbus_chrg` applies  $V_{\text{TRM}}$  (3.3V) to  $V_{\text{BUS}}$ , where as `vbus_drv` uses the 5V charge pump output. While  $V_{\text{TRM}}$  is sufficient for signaling purposes, it does not meet the 4.4V minimum for  $V_{\text{BUS}}$ .

### VTRM

$V_{\text{TRM}}$  supplies a regulated 3.3V to the D+, D- output drivers, pull-up resistors and other circuitry internal to the MIC2555. A small filter capacitor is required to insure the regulator remains stable under all operating conditions. A good quality 1 $\mu\text{F}$  capacitor is sufficient for this purpose.

$V_{\text{TRM}}$  can be used to supply small amounts of current to other system functions, typically 3 mA or less. However, trying to source more current can reduce output drive on D+, D- by stealing current from the differential driver.

### ID

ID detects the arrival or departure of a peripheral device, and differentiates between USB and non-USB devices. To accomplish this, ID is pulled-up by a resistance of approximately 100 k $\Omega$  connected to  $V_{\text{BAT}}$  and the voltage at ID monitored by a set of comparators. When no device is present, ID is pulled high and NO DEVICE condition is reported. When a Mini-A plug is inserted into the system's Mini-AB receptacle, ID is connected to ground by the Mini-A plug, which triggers the MIC2555 to indicate a USB device is present.

Non-USB peripherals use a modified Mini-A plug or non-standard cable assembly with a resistor connected between ID and ground. When connected, this forms a resistor divider such that a voltage of approximately ½ V<sub>BAT</sub> appears at MIC2555's ID pin, indicating a non-USB device is present.

Additionally, ID can be used to signal non-USB devices. This is accomplished by grounding ID through a low value resistor (~ 1 kΩ), dropping the ID voltage from ½ V<sub>BAT</sub> to nearly zero, which can be detected by the attached device. This switch is activated by the id\_gnd\_out bit in Control Register 2.

**C-, C+, C++**

C-, C+ and C++ are the capacitors required for charge pump operation. C- and C+ are the connections to the 'flying' capacitor, which creates the pumping effect. C++ is the reservoir capacitor that stores the 5V supplied to V<sub>BUS</sub> when vbus\_drv is asserted.

Because the input source is a low voltage and the charge pump's regulator is set to limit V<sub>OUT</sub> to 5V, these capacitors need only be rated at 6 WVDC, which helps reduce physical size and cost.

**GND\_A, GND\_D**

MIC2555 uses separate ground lines within the chip to isolate digital noise from analog signals. Ultimately, these two grounds need to be tied together. This is best done by having both grounds return separately to the power source and join at the bypass capacitor.

**RESET/**

System reset. Returns all control register bits to their default settings. MIC2555 is not equipped with an internal power-on reset generator, and thus relies upon the system for its reset at power up.

**DAT\_VP\_RX, SE0\_VM\_TX, RCV**

DAT\_VP\_RX, SE0\_VM\_TX and RCV provide the data transfer interface between the system controller and MIC2555. RCV is an output only pin, supplying the output of a differential receiver monitoring the D+, D- pins, while DAT\_VP\_RX, SE0\_VM\_TX are bi-directional (I/O) pins and change function in accordance with different USB and UART mode selections.

In UART mode, DAT\_VP\_RX and SE0\_VM\_TX are the primary data transmit and receive pins.

In USB mode, the setting of the dat\_se0 determines their action, as described in the tables below.

**USB mode:**

The transceiver transmits USB data onto the D+, D- lines when:

Conditions:

uart\_en = 0  
OE\_INT = 0

Operation of the DAT\_VP\_RX, SE0\_VM\_TX and RCV pins during transmission is shown below.

**USB Transmit Operation**

USB Mode	Inputs		Outputs		
	DAT_VP_RX	SE0_VM_TX	D+	D-	RCV
DAT-SE0	0	0	0	1	unused
	1	0	1	0	unused
	0	1	0	0	unused
	1	1	0	0	unused
VP-VM	0	0	0	0	Undefined
	1	0	1	0	1
	0	1	0	1	0
	1	1	1	1	Undefined

The transceiver receives USB data from the D+, D- lines when:

Conditions:

uart\_en = 0  
OE\_INT/ = 0

Operation of the DAT\_VP\_RX, SE0\_VM\_TX and RCV pins during receive is shown on the following page.

**USB Receive Operation**

USB Mode	Suspend	Inputs		Outputs		
		D+	D-	DAT_VP_RX	SE0_VM_TX	RCV
DAT-SE0	0	0	0	undefined	1	n/a
	0	1	0	1	0	n/a
	0	0	1	0	0	n/a
	0	1	1	undefined	0	n/a
	11	0	0	0	1	n/a
	1	1	0	1	0	n/a
	1	0	1	0	0	n/a
	1	1	1	1	0	n/a
VP-VM	0	0	0	0	0	undefined
	0	1	0	1	0	1
	0	0	1	0	1	0
	0	1	1	1	1	undefined
	1	0	0	0	0	n/a
	1	1	0	1	0	n/a
	1	0	1	0	1	n/a
	1	1	1	1	1	n/a

If the transceiver is in the DAT-SE0 mode, and the suspend bit has not been set, then the DAT\_VP\_RX pin always follows the output of the differential receiver during receive operation. The DAT\_SE0 pin is not gated by the outputs of the single ended receivers. In the VP-VM mode, the RCV pin always follows the output of the differential receiver. The RCV pin is not gated by the outputs of the single ended receivers.

**OE\_INT/**

The “output enable – interrupt bar” (OE\_INT/) pin has four modes of operation, shown in the table below. Suspend modes are controlled by the oe\_int\_en bit found in Control Register 1.

**OE\_INT/ Operating Modes**

suspend	oe_int_en	I/O	Description
0	x	Input	OE_INT/ acts as output enable, and controls direction of DAT_VP_RX, SE0_VM_TX, D+ and D-
1	0	Input	OE_INT/ is an input, but does not control anything
1	1	Output	OE_INT/ is asserted low if interrupt condition exists



**SCL, SDA**

The serial clock (SCL) and serial data (SDA) signals implement a two-wire I<sup>2</sup>C serial bus for control of the MIC2555. As with all I<sup>2</sup>C busses the MIC2555 shares a common external pull-up resistor on each line.

**INT/**

The interrupt (INT/) pin is asserted while an interrupt condition exists. It is an open drain output so that it can be wire-ORed with other interrupt signals, and requires an external pull-up resistor to provide a logic output. The pull-up voltage must not be greater than V<sub>BAT</sub>.

**ADR0**

Because some systems may have more than one transceiver on the I<sup>2</sup>C bus, OTG Transceivers have been assigned four I<sup>2</sup>C Address locations by Philips.

MIC2555 address: 01011xxb (Bit order: A6 → A0)

The ADR0 pin and MIC2555's 'dash number' control the 'xx' of MIC2555's address, where -0 or -1 specifies the higher order bit's value:

Part Number	Address Range
MIC2555BML-0	0x
MIC2555BML-1	1x

Where x = the state of ADR0

**D+, D-**

The data plus (D+) and data minus (D-) pins output the USB data signals. When operating as a non-USB transceiver, the role of D+, D- change:

**UART mode:**

D+ = RXD

D- = TXD

**GPIO\_1\_TX, GPIO\_0\_RX, GPIO\_2**

GPIO\_0, GPIO\_1, and GPIO\_2 are general purpose I/Os that can be used as data ports or interrupt sources for the system controller, display drivers or power switches for actuators or annunciators.

These GPIO have open drain outputs capable of sinking at least 10 mA, can be wire ORed together, and may be pulled above the MIC2555's operating supply voltage, but not beyond the 6V absolute maximum allowed. As logic inputs, the GPIO logic thresholds are standard CMOS thresholds set by V<sub>DD\_LGC</sub> voltage.

The GPIO Input Register is a read-only register and shows real time status of the GPIOs, independent of other I/O settings. The GPIO Output Register holds the desired output value for each I/O. Each I/O can act as an independent interrupt source and can be programmed for triggering on T → F, F → T, or either transition.

The GPIO pins serve double duty as active signal pins when called into action by the appropriate control bit:

GPIO\_0 = Secondary UART Transmit input.

GPIO\_1 = Secondary UART Receive output.

GPIO\_2 = External charge pump oscillator input.

## Serial Controller

### Register Map

REGISTER NAME	ADDRESS	ACCESS	BIT 7	BIT 6	BIT 5	BIT 4	BIT 3	BIT 2	BIT 1	BIT 0
Vendor ID	00	R	x8D							
	01	R	x05							
Product ID	02	R	xB0 see Note 1							
	03	R	x55 see Note 1							
Control Register 1	04	RS	uart_io	uart_en	oe_int_en	bdis_acon_en	test bit	dat_se0	suspend	speed
	05	RC								
Control Register 2	06	RS	vbus_chrg	vbus_dischrg	vbus_drv	id_gnd_out	dm_pull-down	dp_pull-down	dm_pull-up	dp_pull-up
	07	RC								
Interrupt Source	08	R	cr_int	bdis_acon (sess_end)	id_float	se_dm	id_gnd_in	se_dp	sess_vld	vbus_vld
Undefined	09									
Interrupt Latch	0A	RS	cr_int	bdis_acon (sess_end)	id_float	se_dm	id_gnd_in	se_dp	sess_vld	vbus_vld
	0B	RC								
Interrupt Mask False	0C	RS	cr_int	bdis_acon (sess_end)	id_float	se_dm	id_gnd_in	se_dp	sess_vld	vbus_vld
	0D	RC								
Interrupt Mask True	0E	RS	cr_int	bdis_acon (sess_end)	id_float	se_dm	id_gnd_in	se_dp	sess_vld	vbus_vld
	0F	RC								
Undefined	10									
	11									
Control Register 3	12	RS	scl_en	rcs_dis	ext_osc	sess_end_en	cr_int_sel	id_det_off	cp_off	pwr_dn
	13	RC								
GPIO Output Enable	14	RS	0	0	0	0	0	GPIO_2	GPIO_1	GPIO_0
	15	RC								
GPIO Output	16	RS	0	0	0	0	0	GPIO_2	GPIO_1	GPIO_0
	17	RC								
GPIO Input	18	R	0	0	0	0	0	GPIO_2	GPIO_1	GPIO_0
Undefined	19									
GPIO Interrupt	1A	RS	scl_en	rcs_dis	ext_osc	sess_end_en	cr_int_sel	id_det_off	cp_off	pwr_dn
	1B	RC								
GPIO Mask False	1C	RS	0	0	0	0	0	GPIO_2	GPIO_1	GPIO_0
	1D	RC								
GPIO Mask True	1E	RS	0	0	0	0	0	GPIO_2	GPIO_1	GPIO_0
	1F	RC								

#### Notes:

1. These values will change with chip revision level and are assigned by Micrel at the time of manufacture.
2. All bits reset to zero, except those listed in **WHITE**, which reset to one.
3. Register bits not listed are undefined.
4. The upper five bits of the GPIO registers always read zero.

## Control Bit Locator

Control Bit	Location				
	Control Register 1	Control Register 2	Control Register 3	Interrupt Source	GPIO Interrupt
bdis_acon, (sess_end)				B6	
bdis_acon_en	B4				
cp_off			B1		
cr_int				B7	
cr_int_sel			B3		
dat_se0	B2				
dm_pull-down		B3			
dm_pull-up		B1			
dp_pull-down		B2			
dp_pull-up		B0			
ext_osc			B5		
GPIO_0					B0
GPIO_1					B1
GPIO_2					B2
id_det_off			B2		
id_float				B5	
id_gnd_in				B3	
id_gnd_out		B4			
oe_int_en	B5				
rcs_dis			B6		
scl_en			B7		
se_dm				B4	
se_dp				B2	
sess_end_en			B4		
sess_vld				B1	
pwr_dn			B0		
speed	B0				
suspend	B1				
test bit	B3				
uart_en	B6				
uart_io	B7				
vbus_chrg		B7			
vbus_dischrg		B6			
vbus_drv		B5			
vbus_vld				B0	

## Serial Controller Register Bits

### Example Table Format

Column Titles				
Field name	Size (bits)	Access	Register Addresses <sup>(1)</sup>	Description

Note:

1. Access type "rd/s/c" denotes a field that can be read, set to 1 or cleared to 0. The register can be read from either of the Addresses indicated. When writing to the "set" Address, any 1s that are written cause the associated bit to be set. When writing to the "clr" (Clear) Address, any 1s that are written cause the associated bit to be cleared.

### Device ID Registers

				MSB -> Higher byte of two byte word LSB -> Lower byte of two byte word
vendor_id	16	rd	00h	USB-IF Vendor ID number. Address 00h contains lower byte of Vendor ID. Address 01h contains upper byte of Vendor ID.
product_id	16	rd	02h	A number unique to each manufacturer, for each device type produced. The manufacturer assigns this number. Address 02h contains lower byte. Address 03h contains upper byte.

**Control Register 1**

Set & Clear			set – 04h clr – 05h	1 → set = 1 1 → clr = 0
speed	1	rd/s/c	bit 0	0 = USB Low Speed mode 1 = USB Full Speed mode
suspend	1	rd/s/c	bit 1	0 = Full power mode 1 = Low power mode
dat_se0	1	rd/s/c	bit 2	0 = VP-VM USB mode 1 = DAT-SE0 USB mode
test bit	1	rd/s/c	bit 3	Not used
bdis_acon_en	1	rd/s/c	bit 4	0 = No action. 1 = Attaches pull-up resistor to D+ after detecting SE0 condition and sets interrupt flag.
Oe_int_en	1	rd/s/c	bit 5	0 = OE_INT/ is an input. 1 = OE_INT/ becomes an output and is asserted LOW when interrupt occurs, if suspend = 1. If suspend = 0, pin remains an input.
Uart_en	1	rd/s/c	bit 6	0 = USB mode 1 = UART mode
uart_io	1	rd/s/c	bit 7	0 = GPIO pins operate as standard GPIO. 1 = GPIO_0 = 2 <sup>nd</sup> UART RX GPIO_1 = 2 <sup>nd</sup> UART TX GPIO_2 = standard GPIO

**Control Register 2**

Set & Clear			set – 06h clr – 07h	1 → set = 1 1 → clr = 0
dp_pull-up	1	rd/s/c	bit 0	1 = Connect pull-up to D+
dm_pull-up	1	rd/s/c	bit 1	1 = Connect pull-up to D-
dp_pull-down	1	rd/s/c	bit 2	1 = Connect pull-down to D+
dm_pull-down	1	rd/s/c	bit 3	1 = Connect pull-down to D-
id_gnd_out	1	rd/s/c	bit 4	1 = Connect ID pin to ground
vbus_drv	1	rd/s/c	bit 5	1 = Power VBUS with charge pump
vbus_dischrg	1	rd/s/c	bit 6	1 = Discharge VBUS through a resistor
vbus_chrg	1	rd/s/c	bit 7	1 = Charge VBUS through a resistor

**Control Register 3**

Set & Clear			set - 12h clr - 13h	1 → set = 1 1 → clr = 0
pwr_dn	1	rd/s/c	bit 0	1 = Power Down mode.
cp_off	1	rd/s/c	bit 1	1 = turns charge pump OFF. (Charge pump generates 5V for powering V <sub>BUS</sub> )
id_det_off	1	rd/s/c	bit 2	0 = ID comparators ON. 1 = Turns ID comparators OFF. Note: Powering down ID comparators does not shut off ID pin pull-up.
cr_int_sel	1	rd/s/c	bit 3	Car Kit interrupt select: 0 = Detect > 3.0V level on D+ 1 = Detect < 0.5V level on D+
sess_end_en	1	rd/s/c	bit 4	0 = no action. 1 = When bdis_acon_en = 0, switches Bit 6 of the Interrupt Register to indicate Session End comparator status.
ext_osc	1	rd/s/c	bit 5	0 = Internal oscillator drives charge pump 1 = External oscillator drives charge pump (Input source = GPIO_2)
rcs_dis	1	rd/s/c	bit 6	0 = Activate current source. Weak pull-up on ID pin. 1 = Disable (bypass) current source pull-up on ID pin. Strong pull-up on ID pin.
scl_en	1	rd/s/c	bit 7	0 = I <sup>2</sup> C clock line only transmits. 1 = Bi-directional I <sup>2</sup> C clock line. Bi-directional clock is required if target device is to be able to control data rate by holding SCL low.

**Interrupt Source Register**

Interrupt Status			rd - 08h	Indicates the current state of signals that can generate an interrupt.
vbus_vld	1	rd	bit 0	1 = V <sub>BUS</sub> > 4.4V (VBUS valid comparator)
sess_vld	1	rd	bit 1	1 = 0.8V < V <sub>BUS</sub> < 2.0V. (Session valid comparator)
se_dp	1	rd	bit 2	1 = D+ pin is HIGH
id_gnd_in	1	rd	bit 3	1 = ID pin grounded
se_dm	1	rd	bit 4	1 = D- pin is HIGH
id_float	1	rd	bit 5	1 = ID pin floating
bdis_acon (sess_end)	1	rd	bit 6	If: bdis_acon_en = 1 1 = SE0 has been detected, transceiver asserted dp_pullup after detecting B-device disconnect. If bdis_acon_en = 0, sess_end_en = 1 1 = V <sub>BUS</sub> < 0.8V. (Session End comparator output = TRUE)
cr_int	1	rd	bit 7	1 = car kit interrupt, D+ pin has seen a pulse above the interrupt level

**Interrupt Latch 1**

Interrupt Source			set – 0Ah clr – 0Bh	Indicates which sources have interrupted. 1 = interrupt.
Vbus_vld	1	rd/s/c	bit 0	
sess_vld	1	rd/s/c	bit 1	
se_dp	1	rd/s/c	bit 2	
id_gnd_in	1	rd/s/c	bit 3	
se_dm	1	rd/s/c	bit 4	
id_float	1	rd/s/c	bit 5	
bdis_acon (sess_end)	1	rd/s/c	bit 6	
cr_int	1	rd/s/c	bit 7	

**Interrupt Mask False**

False Interrupt Mask			set – 0Ch clr – 0Dh	Enables interrupts on transition from TRUE to FALSE 1 → set = 1, Interrupt on T→F. 1 → clr = 0, no interrupt.
Vbus_vld	1	rd/s/c	bit 0	
sess_vld	1	rd/s/c	bit 1	
se_dp	1	rd/s/c	bit 2	
id_gnd_in	1	rd/s/c	bit 3	
se_dm	1	rd/s/c	bit 4	
id_float	1	rd/s/c	bit 5	
bdis_acon (sess_end)	1	rd/s/c	bit 6	
cr_int	1	rd/s/c	bit 7	

**Interrupt Mask True**

True Interrupt Mask			set – 0Eh clr – 0Fh	Enables interrupts on transition from FALSE to TRUE. 1 → set = 1, Interrupt on F→T 1 → clr = 0, no interrupt.
vbus_vld	1	rd/s/c	bit 0	
sess_vld	1	rd/s/c	bit 1	
se_dp	1	rd/s/c	bit 2	
id_gnd_in	1	rd/s/c	bit 3	
se_dm	1	rd/s/c	bit 4	
id_float	1	rd/s/c	bit 5	
bdis_acon (sess_end)	1	rd/s/c	bit 6	
cr_int	1	rd/s/c	bit 7	

**GPIO Output Enable**

Set & Clear			set – 14h clr – 15h	1 → set = 1, GPIO = OUTPUT. 1 → clr = 0, GPIO = INPUT.
GPIO_0	1	rd/s/c	bit 0	
GPIO_1	1	rd/s/c	bit 1	
GPIO_2	1	rd/s/c	bit 2	
	1	rd/s/c	bit 3	
	1	rd/s/c	bit 4	
	1	rd/s/c	bit 5	
	1	rd/s/c	bit 6	
	1	rd/s/c	bit 7	

**GPIO Output**

Set & Clear			set – 16h clr – 17h	1 → set = 1 at GPIO OUTPUT. 1 → clr = 0 at GPIO OUTPUT.
GPIO_0	1	rd/s/c	bit 0	
GPIO_1	1	rd/s/c	bit 1	
GPIO_2	1	rd/s/c	bit 2	
	1	rd/s/c	bit 3	
	1	rd/s/c	bit 4	
	1	rd/s/c	bit 5	
	1	rd/s/c	bit 6	
	1	rd/s/c	bit 7	

**GPIO Input**

Read Status			rd – 18h	Read current state of GPIO input
GPIO_0	1	rd	bit 0	
GPIO_1	1	rd	bit 1	
GPIO_2	1	rd	bit 2	
	1	rd	bit 3	
	1	rd	bit 4	
	1	rd	bit 5	
	1	rd	bit 6	
	1	rd	bit 7	

**GPIO Interrupt Latch**

Interrupt Source			set – 1Ah clr – 1Bh	Indicates which sources have interrupted. 1 = interrupt.
GPIO_0	1	rd/s/c	bit 0	
GPIO_1	1	rd/s/c	bit 1	
GPIO_2	1	rd/s/c	bit 2	
	1	rd/s/c	bit 3	
	1	rd/s/c	bit 4	
	1	rd/s/c	bit 5	
	1	rd/s/c	bit 6	
	1	rd/s/c	bit 7	

**GPIO Interrupt Mask False**

Set & Clear			set – 1Ch clr – 1Dh	Enables interrupts on transition from TRUE to FALSE 1 → set = 1, Interrupt on T→F. 1 → clr = 0, no interrupt.
GPIO_0	1	rd/s/c	bit 0	
GPIO_1	1	rd/s/c	bit 1	
GPIO_2	1	rd/s/c	bit 2	
	1	rd/s/c	bit 3	
	1	rd/s/c	bit 4	
	1	rd/s/c	bit 5	
	1	rd/s/c	bit 6	
	1	rd/s/c	bit 7	

**GPIO Interrupt Mask True**

Set & Clear			set – 1Eh clr – 1Fh	Enables interrupts on transition from FALSE to TRUE. 1 → set = 1, Interrupt on F→T. 1 → clr = 0, no interrupt.
GPIO_0	1	rd/s/c	bit 0	
GPIO_1	1	rd/s/c	bit 1	
GPIO_2	1	rd/s/c	bit 2	
	1	rd/s/c	bit 3	
	1	rd/s/c	bit 4	
	1	rd/s/c	bit 5	
	1	rd/s/c	bit 6	
	1	rd/s/c	bit 7	

Note:  
 1. Access type “rd/s/c” denotes a field that can be read, set to 1 or cleared to 0. The register can be read from either of the Addresses indicated. When writing to the “set” Address, any 1’s that are written cause the associated bit to be set. When writing to the “clr” (Clear) Address, any 1s that are written cause the associated bit to be cleared.

**Example Serial Controller Register Settings**

**Example**

Location	Condition	BIT 7	BIT 6	BIT 5	BIT 4	BIT 3	BIT 2	BIT 1	BIT 0
Target register	Initial state	0	0	1	0	1	0	0	0
‘Set’ register	Data loaded into ‘set’ register	1	0	0	0	1	0	0	0
Target register	Resulting state	1	0	1	0	1	0	0	0
‘Clear’ register	Data loaded into ‘Clear’ register	1	0	0	0	1	0	0	0
Target register	Resulting state	0	0	1	0	0	0	0	0

**PCB Layout Recommendation**

Although the USB standard and applications are not based in an impedance-controlled environment, a properly designed PCB layout is recommended for optimal transceiver performance. The suggested PCB layout hints are as follows:

- Match signal line traces (VP/VM, D+ D-) to 40ps, approximately 1/3-inch if possible. FR-4 PCB material propagation is about 150ps/inch, so to

minimize skew, try to keep VP/VM, D+, D- traces as short as possible.

- For every signal line trace width (w), separate the signal lines by 1.5-2 widths. Place all other traces at >2w from all signal line traces.
- Control signal line impedances to ±10%.
- Keep RS as close to the IC as possible, with equal distance between RS and the IC for both D+ and D-.



**Package Information**

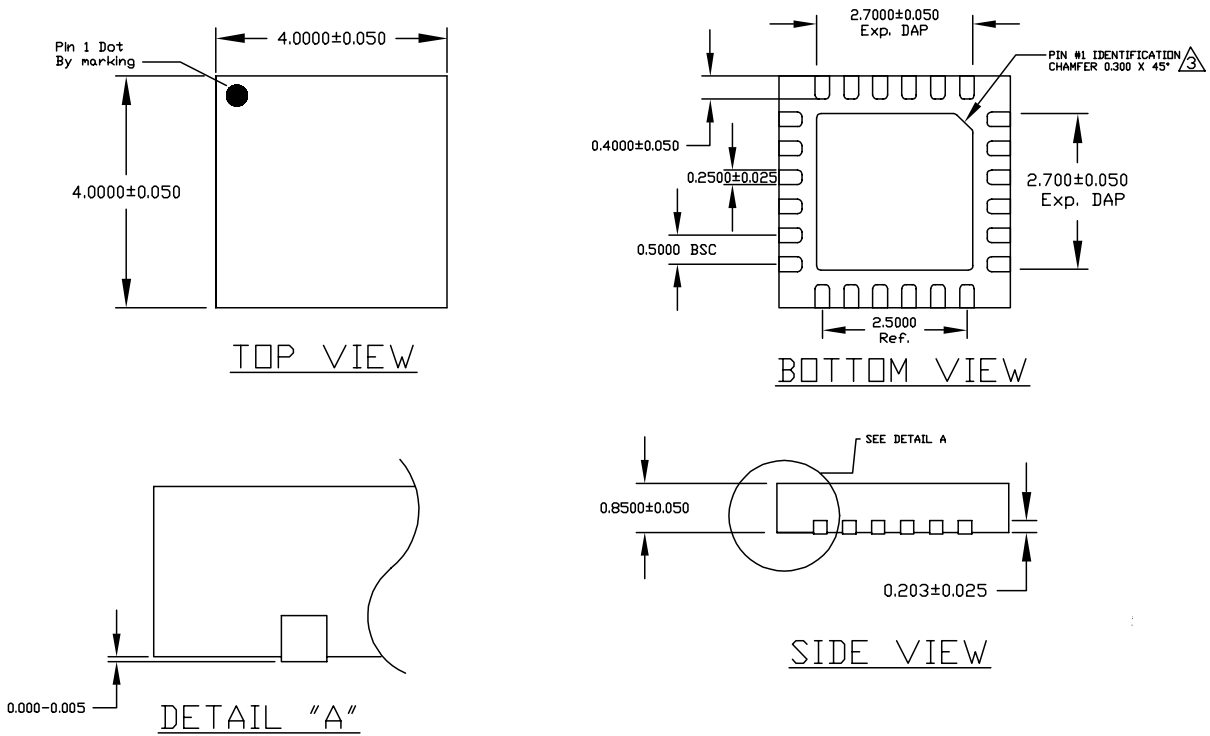

NOTE:

1. ALL DIMENSIONS ARE IN MILLIMETERS (mm).
2. THE PIN#1 IDENTIFIER MUST EXIST ON THE TOP SURFACE OF PACKAGE BY USING IDENTIFICATION MARK OR OTHER FEATURE OF PACKAGE BODY.
3. CHAMFER STYLE PIN 1 IDENTIFIER ON BOTTOM SIDE

**24-Pin MLF (ML)**

**MICREL, INC. 2180 FORTUNE DRIVE SAN JOSE, CA 95131 USA**  
 TEL +1 (408) 944-0800 FAX +1 (408) 474-1000 WEB <http://www.micrel.com>

The information furnished by Micrel in this data sheet is believed to be accurate and reliable. However, no responsibility is assumed by Micrel for its use. Micrel reserves the right to change circuitry and specifications at any time without notification to the customer.

Micrel Products are not designed or authorized for use as components in life support appliances, devices or systems where malfunction of a product can reasonably be expected to result in personal injury. Life support devices or systems are devices or systems that (a) are intended for surgical implant into the body or (b) support or sustain life, and whose failure to perform can be reasonably expected to result in a significant injury to the user. A Purchaser's use or sale of Micrel Products for use in life support appliances, devices or systems is a Purchaser's own risk and Purchaser agrees to fully indemnify Micrel for any damages resulting from such use or sale.

© 2004 Micrel, Incorporated.