

TOSHIBA BIPOLAR LINEAR INTEGRATED CIRCUIT SILICON MONOLITHIC

TA2063F

FILTER IC FOR Σ - Δ MODULATION SYSTEM DA CONVERTER

The TA2063F is an analog filter IC for Σ - Δ modulation system DA converter.

Using the TA2063F in combination the TC9268/78/76 (the Σ - Δ modulation system DA converter with a built-in digital filter), it is possible to construct a DA conversion system with less external parts.

FEATURES

- Built-in CR for LPFs and output (differential) amplifiers for the left and right channel.
- Single power supply operation.
- Noise distortion factor and S/N ratio are as follows (when operating at +5V single power supply) :
 - Noise distortion factor : -90dB (Typ.)
 - S/N : 100dB (Typ.)
- Compatible TA2009F.

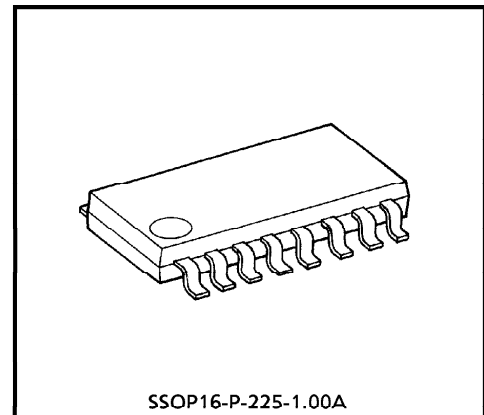

Weight : 0.14g (Typ.)

PIN CONNECTION (TOP VIEW)

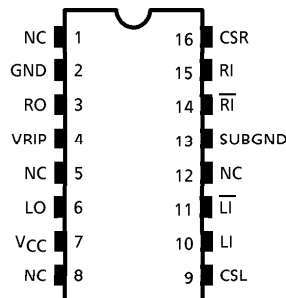

961001EBA2

- TOSHIBA is continually working to improve the quality and the reliability of its products. Nevertheless, semiconductor devices in general can malfunction or fail due to their inherent electrical sensitivity and vulnerability to physical stress. It is the responsibility of the buyer, when utilizing TOSHIBA products, to observe standards of safety, and to avoid situations in which a malfunction or failure of a TOSHIBA product could cause loss of human life, bodily injury or damage to property. In developing your designs, please ensure that TOSHIBA products are used within specified operating ranges as set forth in the most recent products specifications. Also, please keep in mind the precautions and conditions set forth in the TOSHIBA Semiconductor Reliability Handbook.
- The products described in this document are subject to foreign exchange and foreign trade control laws.
- The information contained herein is presented only as a guide for the applications of our products. No responsibility is assumed by TOSHIBA CORPORATION for any infringements of intellectual property or other rights of the third parties which may result from its use. No license is granted by implication or otherwise under any intellectual property or other rights of TOSHIBA CORPORATION or others.
- The information contained herein is subject to change without notice.

BLOCK DIAGRAM

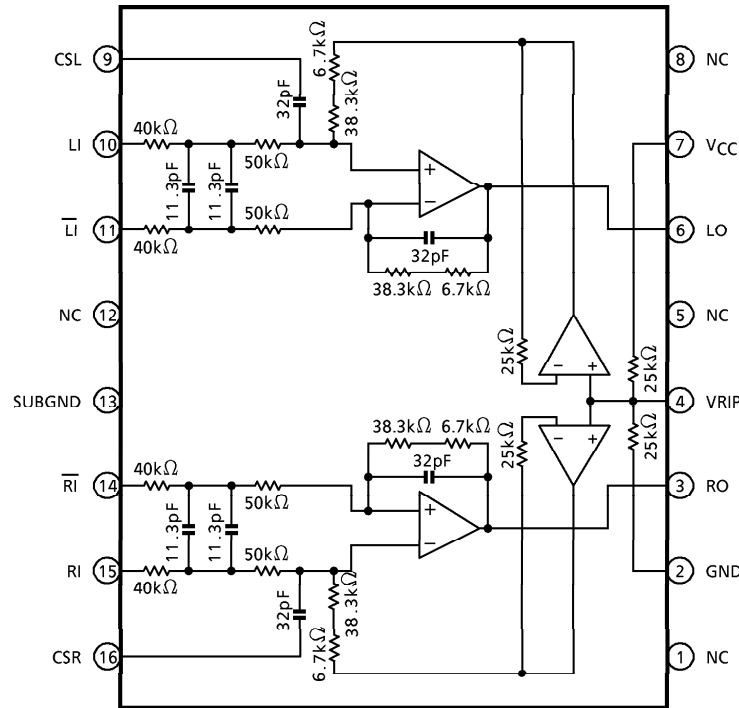

PIN FUNCTION

PIN No.	SYMBOL	I/O	FUNCTION & OPERATION	REMARK
1	NC	—	Non-connecting terminal.	—
2	GND	—	Ground terminal.	—
3	RO	O	R channel analog output terminal.	—
4	VRIP	—	Reference voltage terminal. ($V_{CC}/2$)	See the block diagram.
5	NC	—	Non-connecting terminal.	—
6	LO	O	L channel analog output terminal.	—
7	VCC	—	Supply voltage terminal.	—
8	NC	—	Non-connecting terminal.	—
9	CSL	—	Ground terminal for L channel reverse input side filter.	—
10	LI	I	L channel forward input terminal.	Connect to LO of TC9268/78/76.
11	LI-bar	I	L channel reverse input terminal.	Connect to LO-bar of TC9268/78/76.
12	NC	—	Non-connecting terminal.	—
13	SUBGND	—	Ground terminal.	—
14	RI-bar	I	R channel reverse input terminal.	Connect to RO-bar of TC9268/78/76.
15	RI	I	R channel forward input terminal.	Connect to RO of TC9268/78/76.
16	CSR	—	Ground terminal for R channel reverse input side filter.	—

MAXIMUM RATINGS (Ta = 25°C)

CHARACTERISTIC	SYMBOL	RATING	UNIT
Supply Voltage	V _{CC}	6	V
Power Dissipation	P _D	350 (*)	mW
Operating Temperature	T _{opr}	- 40~85	°C
Storage Temperature	T _{stg}	- 55~150	°C

(*) Reduce 2.8mW/°C at above 25°C.

ELECTRICAL CHARACTERISTICS (Unless otherwise specified, V_{CC} = 5.0V, Ta = 25°C, R_L = 10kΩ)

CHARACTERISTIC	SYMBOL	TEST CIRCUIT	TEST CONDITION	MIN.	TYP.	MAX.	UNIT
Operating Supply Voltage	V _{CC}	—	Ta = - 40~85°C	3.0	5.0	5.5	V
Operating Supply Current	I _{CCQ}	—	V _{in} = 0	5.0	7.0	10	mA
Reference Voltage	VRIP	—	—	—	2.5	—	V
Noise Distortion Factor	THD (1)	—	1kHz, V _i = 1.40V _{rms} (*)	—	- 90	- 85	dB
	THD (2)		10kHz, V _i = 1.40V _{rms} (*)	—	- 81	- 79	
	THD (3)		1kHz, V _i = 140mV _{rms} (*)	—	- 80	- 77	
	S/N	—	1kHz, V _i = 1.40V _{rms} (*)	—	- 100	- 96	dB
Cross Talk	C.T.	—	1kHz, V _i = 1.40V _{rms} (*)	—	- 100	- 95	dB
Attenuation	ATT (1)	—	20kHz	0.03	0.2	0.5	dB
	ATT (2)		80kHz	1.2	3.0	7.0	
Max. Output Level	V _{out}	—	1kHz, V _i = 1.40V _{rms} (*)	1.2	1.26	1.3	V _{rms}

(Note) When the TC9268/78/76 and +5V single power supply are operated

: Full scale = 1.1V_{rms} (Typ.)

(*) B.W. = 400Hz~30kHz

TEST CIRCUIT

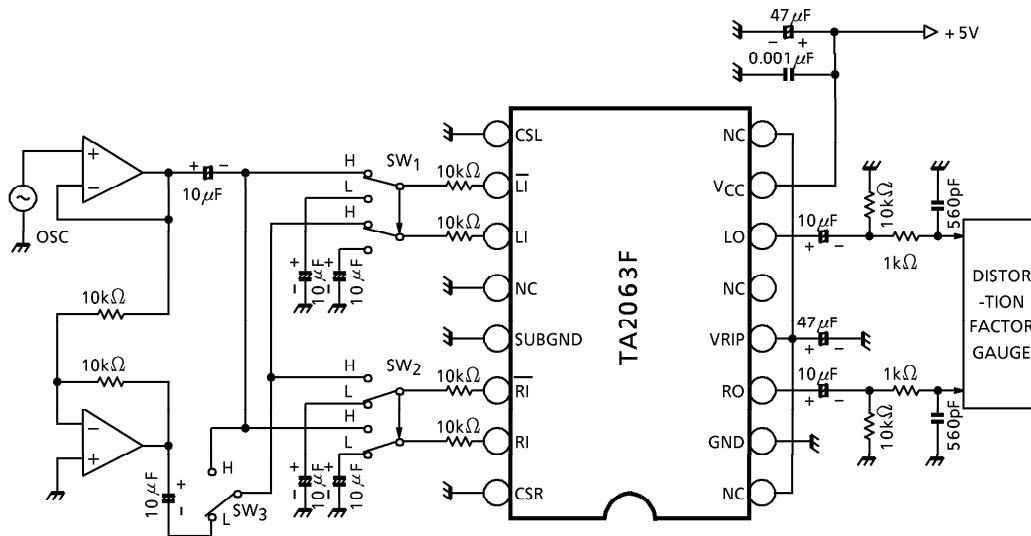

SW ₁	SW ₂	SW ₃	MEASURING ITEM
L	L	—	Operating supply voltage, Reference voltage
L	H	L	Cross talk (R→L)
H	L	L	Cross talk (L→R)
H	H	L	Noise distortion factor, Attenuation, Maximum output level, LR output difference.
H	H	H	Difference balance

APPLICATION CIRCUIT

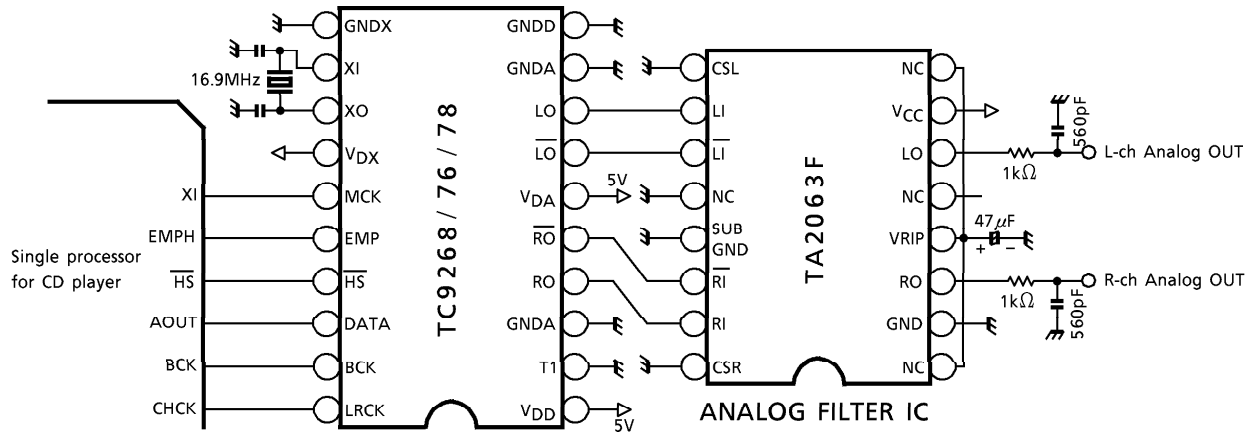

(Cautions)

- Quality of crystal oscillation waveform largely effects S/N ratio. Further, this is also true when system clock is input externally through the XI terminal of pin ⑫.
- Suppress glitch of input signals (LRCK, BCK, DATA) as could as possible.
- The wiring between the TC9268/76/78 output and the analogue filter amplifier input must be made the shortest.
- The capacitor between V_{DA} and G_{NDA} shall be connected as close to the pin as possible.

OUTLINE DRAWING

SSOP16-P-225-1.00A

Unit : mm

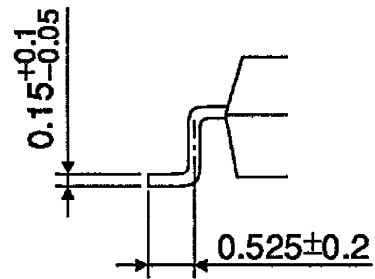
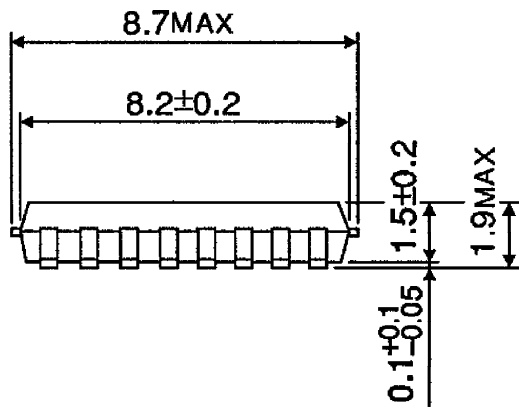
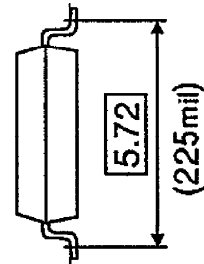
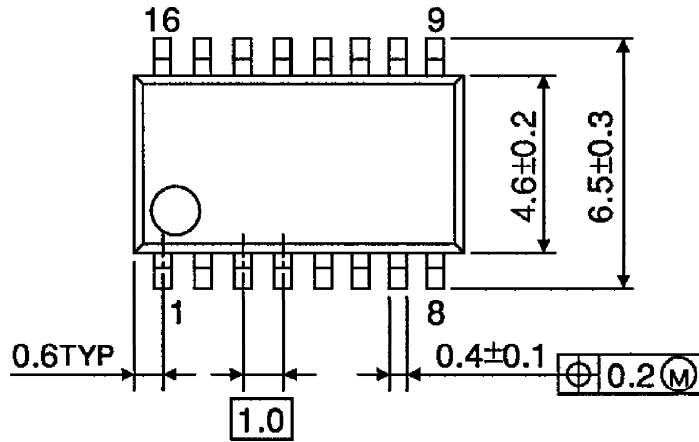

Weight : 0.14g (Typ.)