

8K x 8/9 Dual-Port Static RAM with Sem, Int, Busy

Features

- True Dual-Ported memory cells which allow simultaneous reads of the same memory location
- 8K x 8 organization (CY7C144)
- 8K x 9 organization (CY7C145)
- 0.65-micron CMOS for optimum speed/power
- High-speed access: 15ns
- Low operating power: $I_{CC} = 160$ mA (max.)
- Fully asynchronous operation
- Automatic power-down
- TTL compatible
- Master/Slave select pin allows bus width expansion to 16/18 bits or more
- Busy arbitration scheme provided
- Semaphores included to permit software handshaking between ports
- INT flag for port-to-port communication
- Available in 68-pin PLCC, 64-pin and 80-pin TQFP
- Pin compatible and functionally equivalent to IDT7005/IDT7015

are included on the CY7C144/5 to handle situations when multiple processors access the same piece of data. Two ports are provided permitting independent, asynchronous access for reads and writes to any location in memory. The CY7C144/5 can be utilized as a standalone 64/72-Kbit dual-port static RAM or multiple devices can be combined in order to function as a 16/18-bit or wider master/slave dual-port static RAM. An M/S pin is provided for implementing 16/18-bit or wider memory applications without the need for separate master and slave devices or additional discrete logic. Application areas include interprocessor/multiprocessor designs, communications status buffering, and dual-port video/graphics memory.

Each port has independent control pins: chip enable (\overline{CE}), read or write enable (R/\overline{W}), and output enable (\overline{OE}). Two flags, \overline{BUSY} and \overline{INT} , are provided on each port. \overline{BUSY} signals that the port is trying to access the same location currently being accessed by the other port. The interrupt flag (\overline{INT}) permits communication between ports or systems by means of a mail box. The semaphores are used to pass a flag, or token, from one port to the other to indicate that a shared resource is in use. The semaphore logic is comprised of eight shared latches. Only one side can control the latch (semaphore) at any time. Control of a semaphore indicates that a shared resource is in use. An automatic power-down feature is controlled independently on each port by a chip enable (\overline{CE}) pin or \overline{SEM} pin.

Functional Description

The CY7C144 and CY7C145 are high-speed CMOS 8K x 8 and 8K x 9 dual-port static RAMs. Various arbitration schemes

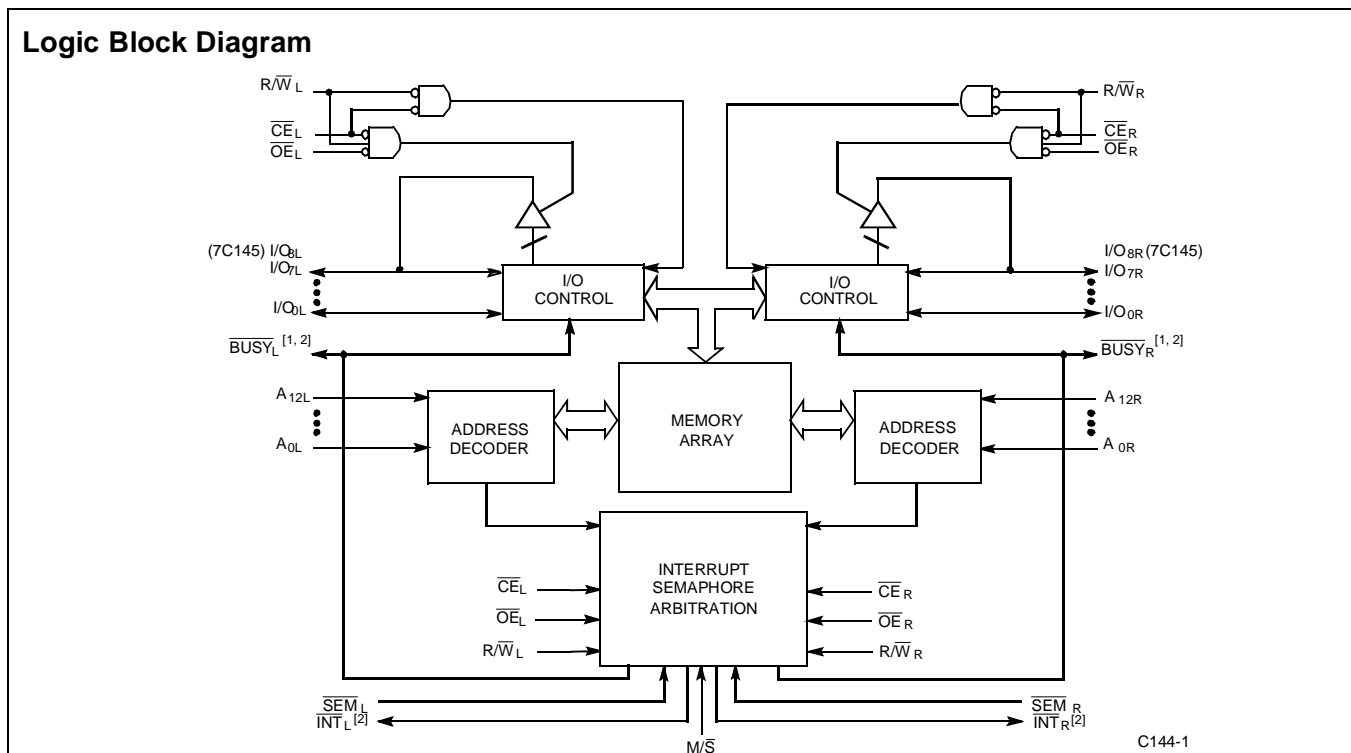

Notes:

1. \overline{BUSY} is an output in master mode and an input in slave mode.
2. Interrupt: push-pull output and requires no pull-up resistor.

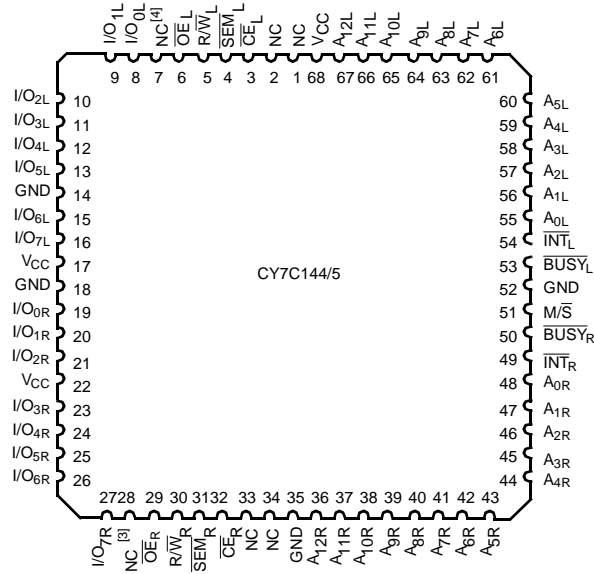
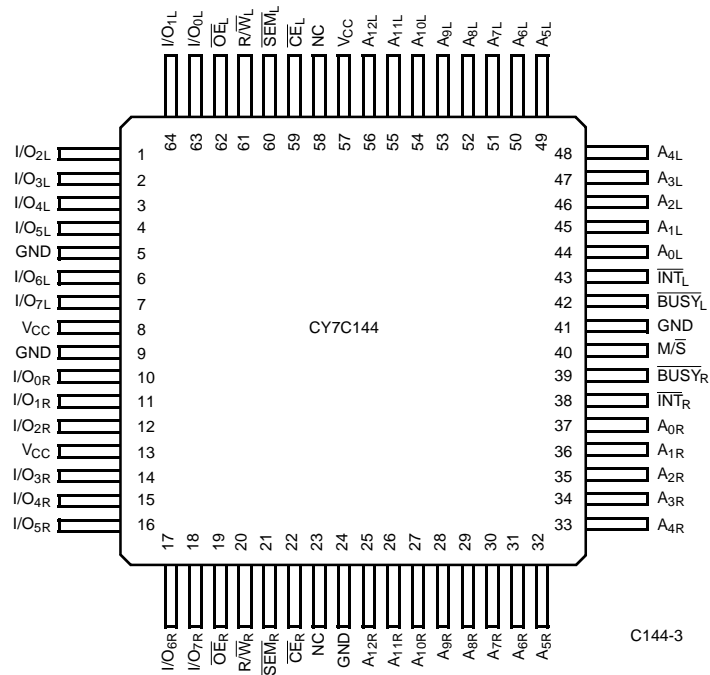
Pin Configurations
**68-Pin PLCC
Top View**

**64-Pin TQFP
Top View**

Notes:

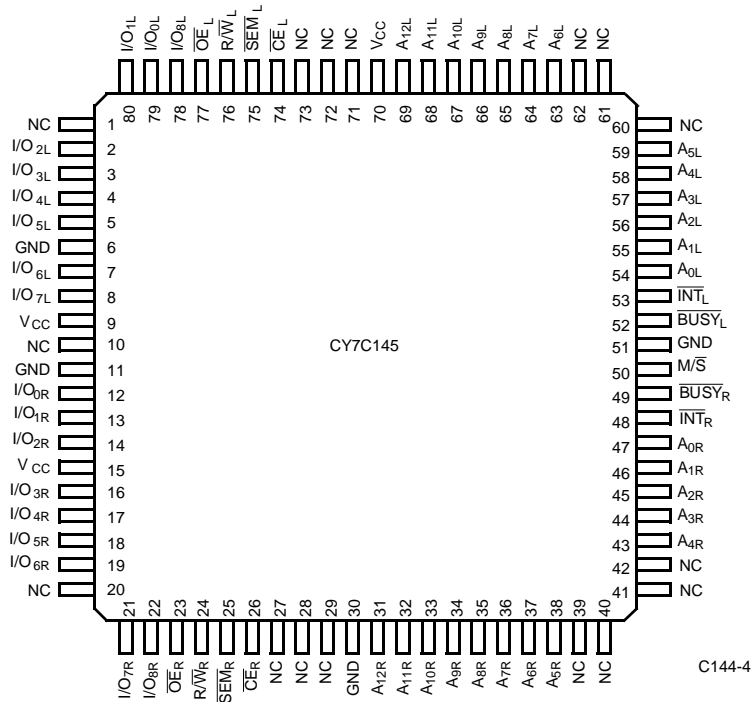
3. I/O_{8R} on the CY7C145.
4. I/O_{8L} on the CY7C145.

Pin Configurations (continued)

80-Pin TQFP
Top View

Pin Definitions

Left Port	Right Port	Description
I/O _{0L-7L} (8L)	I/O _{0R-7R} (8R)	Data bus Input/Output
A _{0L-12L}	A _{0R-12R}	Address Lines
CE _L	CE _R	Chip Enable
OE _L	OE _R	Output Enable
R/W _L	R/W _R	Read/Write Enable
SEM _L	SEM _R	Semaphore Enable. When asserted LOW, allows access to eight semaphores. The three least significant bits of the address lines will determine which semaphore to write or read. The I/O ₀ pin is used when writing to a semaphore. Semaphores are requested by writing a 0 into the respective location.
INT _L	INT _R	Interrupt Flag. INT _L is set when right port writes location 1FFE and is cleared when left port reads location 1FFE. INT _R is set when left port writes location 1FFF and is cleared when right port reads location 1FFF.
BUSY _L	BUSY _R	Busy Flag
M/S		Master or Slave Select
V _{CC}		Power
GND		Ground



Selection Guide

	7C144-15 7C145-15	7C144-25 7C145-25	7C144-35 7C145-35	7C144-55 7C145-55
Maximum Access Time (ns)	15	25	35	55
Maximum Operating Current (mA)	220	180	160	160
Maximum Standby Current for I _{SB1} (mA)	60	40	30	30

Maximum Ratings

(Above which the useful life may be impaired. For user guidelines, not tested.)

Storage Temperature -65°C to +150°C
 Ambient Temperature with Power Applied..... -55°C to +125°C
 Supply Voltage to Ground Potential..... -0.5V to +7.0V
 DC Voltage Applied to Outputs in High Z State..... -0.5V to +7.0V
 DC Input Voltage^[5]..... -0.5V to +7.0V

Output Current into Outputs (LOW) 20 mA
 Static Discharge Voltage >2001V (per MIL-STD-883, Method 3015)
 Latch-Up Current..... >200 mA

Operating Range

Range	Ambient Temperature	V _{CC}
Commercial	0°C to +70°C	5V ± 10%
Industrial	-40°C to +85°C	5V ± 10%

Electrical Characteristics Over the Operating Range

Parameter	Description	Test Conditions	7C144-15 7C145-15		7C144-25 7C145-25		Unit
			Min.	Max.	Min.	Max.	
V _{OH}	Output HIGH Voltage	V _{CC} = Min., I _{OH} = -4.0 mA	2.4		2.4		V
V _{OL}	Output LOW Voltage	V _{CC} = Min., I _{OL} = 4.0 mA		0.4		0.4	V
V _{IH}	Input HIGH Voltage		2.2		2.2		V
V _{IL}	Input LOW Voltage			0.8		0.8	V
I _{Ix}	Input Leakage Current	GND ≤ V _I ≤ V _{CC}	-10	+10	-10	+10	μA
I _{OZ}	Output Leakage Current	Outputs Disabled, GND ≤ V _O ≤ V _{CC}	-10	+10	-10	+10	μA
I _{CC}	Operating Current	V _{CC} = Max., I _{OUT} = 0 mA Outputs Disabled	Com'l	220	180		mA
			Ind		190		
I _{SB1}	Standby Current (Both Ports TTL Levels)	CE _L and CE _R ≥ V _{IH} , f = f _{MAX} ^[7]	Com'l	60	40		mA
			Ind		50		
I _{SB2}	Standby Current (One Port TTL Level)	CE _L or CE _R ≥ V _{IH} , f = f _{MAX} ^[7]	Com'l	130	110		mA
			Ind		120		
I _{SB3}	Standby Current (Both Ports CMOS Levels)	Both Ports CE and CE _R ≥ V _{CC} - 0.2V, V _{IN} ≥ V _{CC} - 0.2V or V _{IN} ≤ 0.2V, f = 0 ^[7]	Com'l	15	15		mA
			Ind		30		
I _{SB4}	Standby Current (One Port CMOS Level)	One Port CE _L or CE _R ≥ V _{CC} - 0.2V, V _{IN} ≥ V _{CC} - 0.2V or V _{IN} ≤ 0.2V, Active Port Outputs, f = f _{MAX} ^[7]	Com'l	125	100		mA
			Ind		115		

Notes:

- Pulse width < 20 ns.
- T_A is the "instant on" case temperature.
- f_{MAX} = 1/t_{RC} = All inputs cycling at f = 1/t_{RC} (except output enable). f = 0 means no address or control lines change. This applies only to inputs at CMOS level standby I_{SB3}.

Electrical Characteristics Over the Operating Range (continued)

Parameter	Description	Test Conditions	7C144-35 7C145-35		7C144-55 7C145-55		Unit
			Min.	Max.	Min.	Max.	
V _{OH}	Output HIGH Voltage	V _{CC} = Min., I _{OH} = -4.0 mA	2.4		2.4		V
V _{OL}	Output LOW Voltage	V _{CC} = Min., I _{OL} = 4.0 mA		0.4		0.4	V
V _{IH}	Input HIGH Voltage		2.2		2.2		V
V _{IL}	Input LOW Voltage			0.8		0.8	V
I _{IX}	Input Leakage Current	GND ≤ V _I ≤ V _{CC}	-10	+10	-10	+10	μA
I _{OZ}	Output Leakage Current	Outputs Disabled, GND ≤ V _O ≤ V _{CC}	-10	+10	-10	+10	μA
I _{CC}	Operating Current	V _{CC} = Max., I _{OUT} = 0 mA Outputs Disabled	Com'l	160	160		mA
			Ind	180	180		
I _{SB1}	Standby Current (Both Ports TTL Levels)	\overline{CE}_L and $\overline{CE}_R \geq V_{IH}$, f = f _{MAX} ^[7]	Com'l	30	30		mA
			Ind	40	40		
I _{SB2}	Standby Current (One Port TTL Level)	\overline{CE}_L or $\overline{CE}_R \geq V_{IH}$, f = f _{MAX} ^[7]	Com'l	100	100		mA
			Ind	110	110		
I _{SB3}	Standby Current (Both Ports CMOS Levels)	Both Ports CE and $\overline{CE}_R \geq V_{CC} - 0.2V$, V _{IN} ≥ V _{CC} - 0.2V or V _{IN} ≤ 0.2V, f = 0 ^[7]	Com'l	15	15		mA
			Ind	30	30		
I _{SB4}	Standby Current (One Port CMOS Level)	One Port \overline{CE}_L or $\overline{CE}_R \geq V_{CC} - 0.2V$, V _{IN} ≥ V _{CC} - 0.2V or V _{IN} ≤ 0.2V, Active Port Outputs, f = f _{MAX} ^[7]	Com'l	90	90		mA
			Ind	100	100		

Capacitance^[8]

Parameter	Description	Test Conditions	Max.	Unit
C _{IN}	Input Capacitance	T _A = 25°C, f = 1 MHz, V _{CC} = 5.0V	10	pF
C _{OUT}	Output Capacitance		15	pF

Note:

8. Tested initially and after any design or process changes that may affect these parameters.

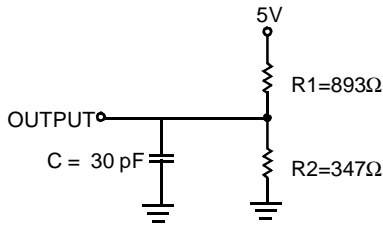
AC Test Loads and Waveforms

(a) Normal Load (Load 1)

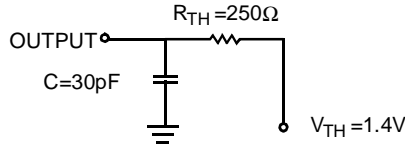
C144-5

(b) Thévenin Equivalent (Load 1)

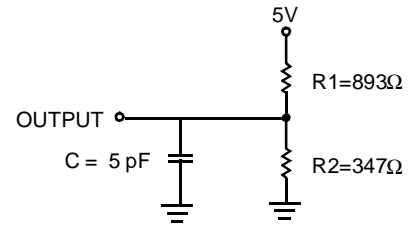
C144-6

(c) Three-State Delay (Load 3)

C144-7

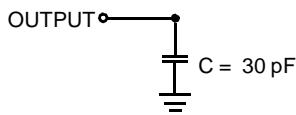
Load (Load 2)

C144-8

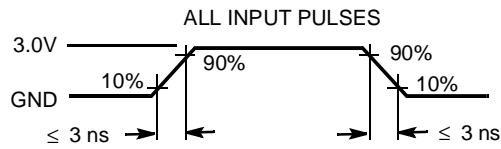

C144-9

Switching Characteristics Over the Operating Range^[9]

Parameter	Description	7C144-15 7C145-15		7C144-25 7C145-25		7C144-35 7C145-35		7C144-55 7C145-55		Unit
		Min.	Max.	Min.	Max.	Min.	Max.	Min.	Max.	
READ CYCLE										
t_{RC}	Read Cycle Time	15		25		35		55		ns
t_{AA}	Address to Data Valid		15		25		35		55	ns
t_{OHA}	Output Hold From Address Change	3		3		3		3		ns
t_{ACE}	\overline{CE} LOW to Data Valid		15		25		35		55	ns
t_{DOE}	\overline{OE} LOW to Data Valid		10		15		20		25	ns
$t_{LZOE}^{[10, 11, 12]}$	\overline{OE} Low to Low Z	3		3		3		3		ns
$t_{HZOE}^{[10, 11, 12]}$	\overline{OE} HIGH to High Z		10		15		20		25	ns
$t_{LZCE}^{[10, 11, 12]}$	\overline{CE} LOW to Low Z	3		3		3		3		ns
$t_{HZCE}^{[10, 11, 12]}$	\overline{CE} HIGH to High Z		10		15		20		25	ns
$t_{PU}^{[12]}$	\overline{CE} LOW to Power-Up	0		0		0		0		ns
$t_{PD}^{[12]}$	\overline{CE} HIGH to Power-Down		15		25		35		55	ns

Notes:

9. Test conditions assume signal transition time of 3 ns or less, timing reference levels of 1.5V, input pulse levels of 0 to 3.0V, and output loading of the specified I_{OL}/I_{OH} and 30-pF load capacitance.
10. At any given temperature and voltage condition for any given device, t_{HZCE} is less than t_{LZCE} and t_{HZOE} is less than t_{LZOE} .
11. Test conditions used are Load 3.
12. This parameter is guaranteed but not tested.

Switching Characteristics Over the Operating Range^[9] (continued)

Parameter	Description	7C144-15 7C145-15		7C144-25 7C145-25		7C144-35 7C145-35		7C144-55 7C145-55		Unit
		Min.	Max.	Min.	Max.	Min.	Max.	Min.	Max.	
WRITE CYCLE										
t _{WC}	Write Cycle Time	15		25		35		55		ns
t _{SCE}	\overline{CE} LOW to Write End	12		20		30		45		ns
t _{AW}	Address Set-Up to Write End	12		20		30		45		ns
t _{HA}	Address Hold From Write End	2		2		2		2		ns
t _{SA}	Address Set-Up to Write Start	0		0		0		0		ns
t _{PWE}	Write Pulse Width	12		20		25		40		ns
t _{SD}	Data Set-Up to Write End	10		15		15		25		ns
t _{HD}	Data Hold From Write End	0		0		0		0		ns
t _{HZWE} ^[11,12]	R/ \overline{W} LOW to High Z		10		15		20		25	ns
t _{LZWE} ^[11,12]	R/ \overline{W} HIGH to Low Z	3		3		3		3		ns
t _{WDD} ^[13]	Write Pulse to Data Delay		30		50		60		70	ns
t _{DDD} ^[13]	Write Data Valid to Read Data Valid		25		30		35		40	ns
BUSY TIMING ^[14]										
t _{BLA}	\overline{BUSY} LOW from Address Match		15		20		20		30	ns
t _{BHA}	\overline{BUSY} HIGH from Address Mismatch		15		20		20		30	ns
t _{BLC}	\overline{BUSY} LOW from \overline{CE} LOW		15		20		20		30	ns
t _{BHC}	\overline{BUSY} HIGH from \overline{CE} HIGH		15		20		20		30	ns
t _{PS}	Port Set-Up for Priority	5		5		5		5		ns
t _{WB}	R/ \overline{W} LOW after \overline{BUSY} LOW	0		0		0		0		ns
t _{WH}	R/ \overline{W} HIGH after \overline{BUSY} HIGH	13		20		30		30		ns
t _{BDD}	\overline{BUSY} HIGH to Data Valid		15		25		35		55	ns
INTERRUPT TIMING ^[14]										
t _{INS}	\overline{INT} Set Time		15		25		25		35	ns
t _{INR}	\overline{INT} Reset Time		15		25		25		35	ns
SEMAPHORE TIMING										
t _{SOP}	SEM Flag Update Pulse (\overline{OE} or SEM)	10		10		15		20		ns
t _{SWRD}	SEM Flag Write to Read Time	5		5		5		5		ns
t _{SPS}	SEM Flag Contention Window	5		5		5		5		ns

Notes:

13. For information on part-to-part delay through RAM cells from writing port to reading port, refer to Read Timing with Port-to-Port Delay waveform.
 14. Test conditions used are Load 2.

Switching Waveforms

Read Cycle No. 1 (Either Port Address Access)^[15, 16]

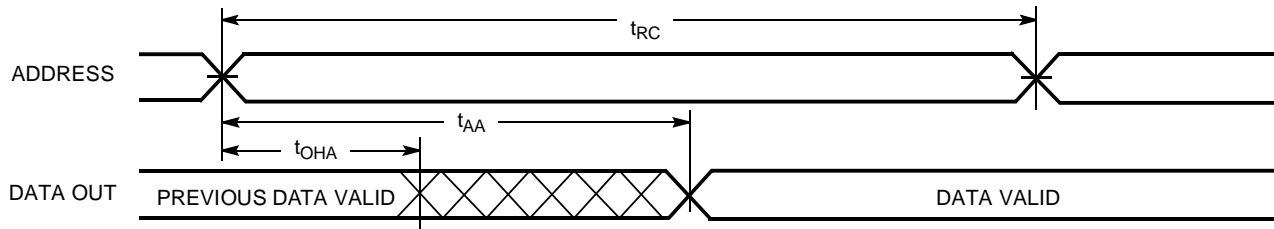

C144-10

Read Cycle No. 2 (Either Port $\overline{CE}/\overline{OE}$ Access)^[15, 17, 18]

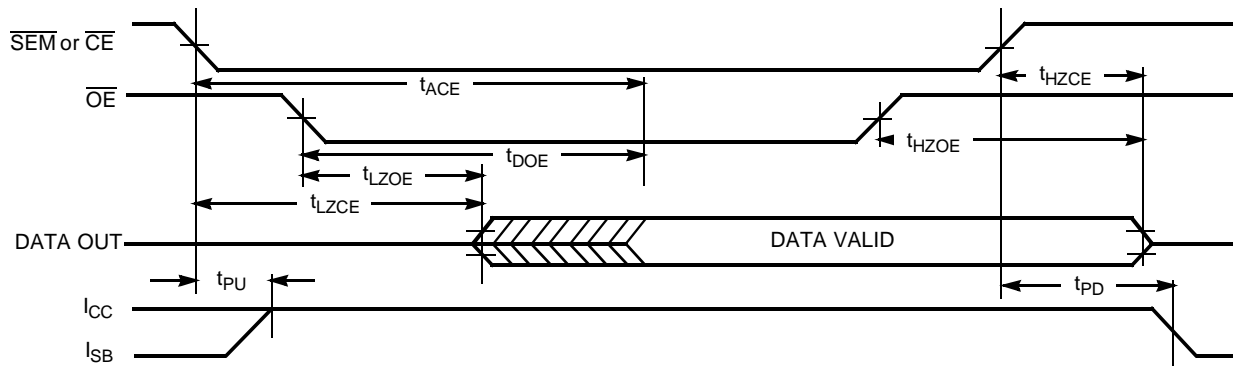

C144-11

Read Timing with Port-to-Port Delay ($M/\overline{S}=L$)^[19, 20]

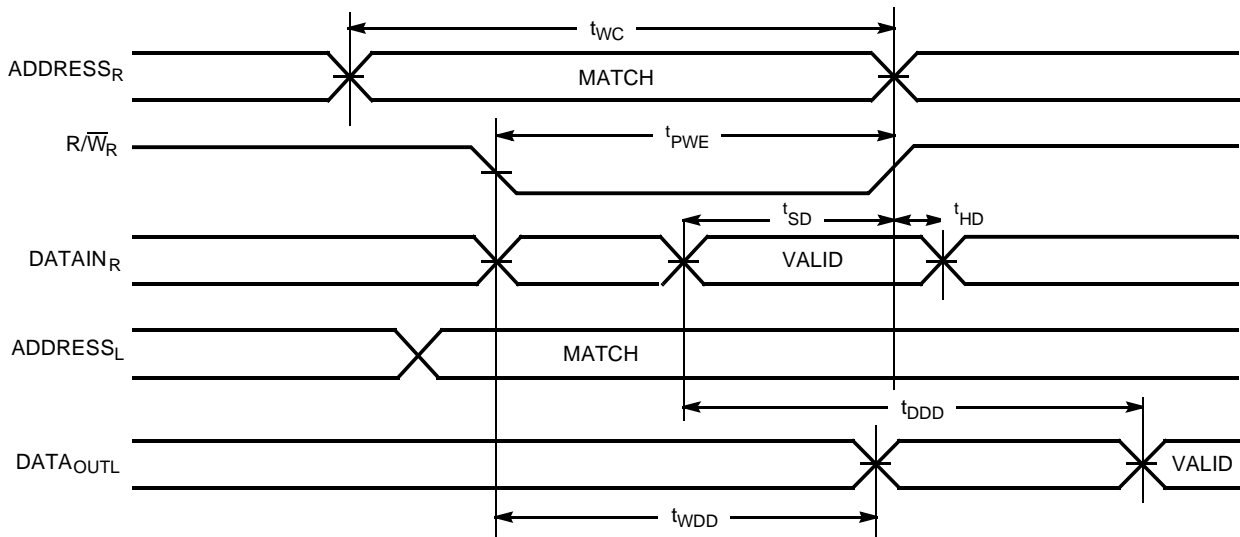

C144-12

Notes:

15. R/\overline{W} is HIGH for read cycle.
16. Device is continuously selected $\overline{CE} = \text{LOW}$ and $\overline{OE} = \text{LOW}$. This waveform cannot be used for semaphore reads.
17. Address valid prior to or coincident with \overline{CE} transition LOW.
18. $\overline{CE}_L = L$, $\overline{SEM} = H$ when accessing RAM. $\overline{CE} = H$, $\overline{SEM} = L$ when accessing semaphores.
19. $\overline{BUSY} = \text{HIGH}$ for the writing port.
20. $\overline{CE}_L = \overline{CE}_R = \text{LOW}$.

Switching Waveforms (continued)

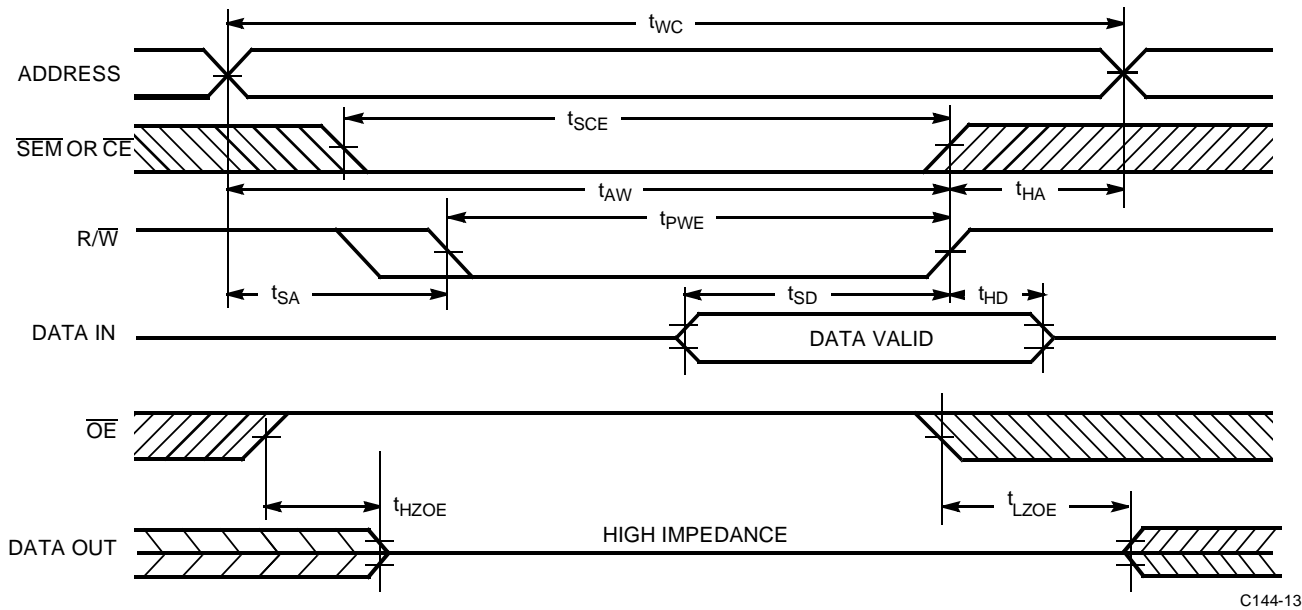
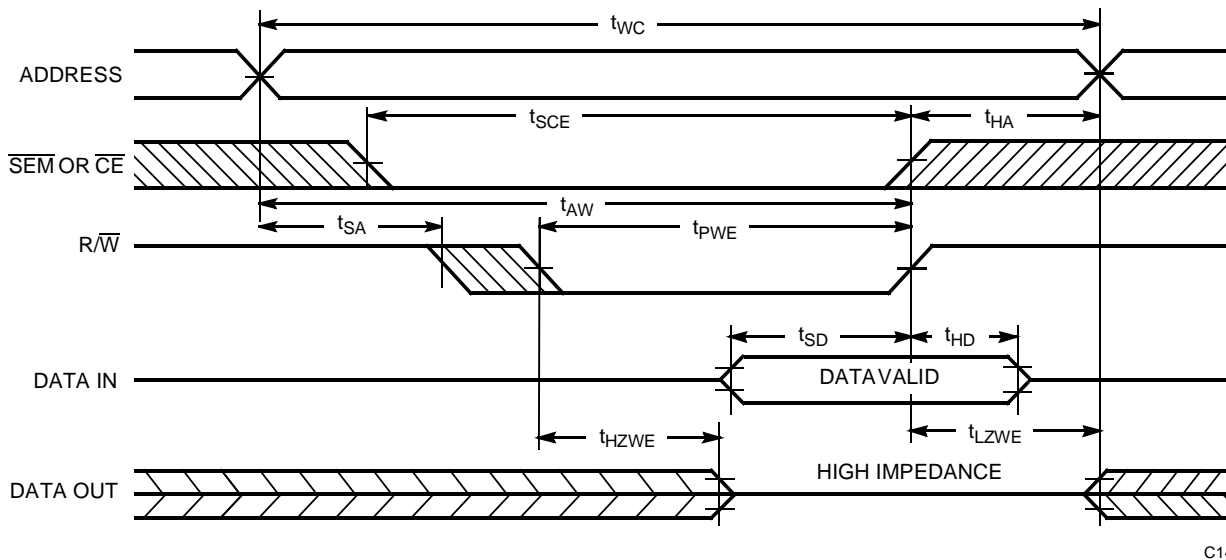
Write Cycle No. 1: \overline{OE} Three-State Data I/Os (Either Port)^[21, 22, 23]

Write Cycle No. 2: R/ \overline{W} Three-State Data I/Os (Either Port)^[21, 23, 24]

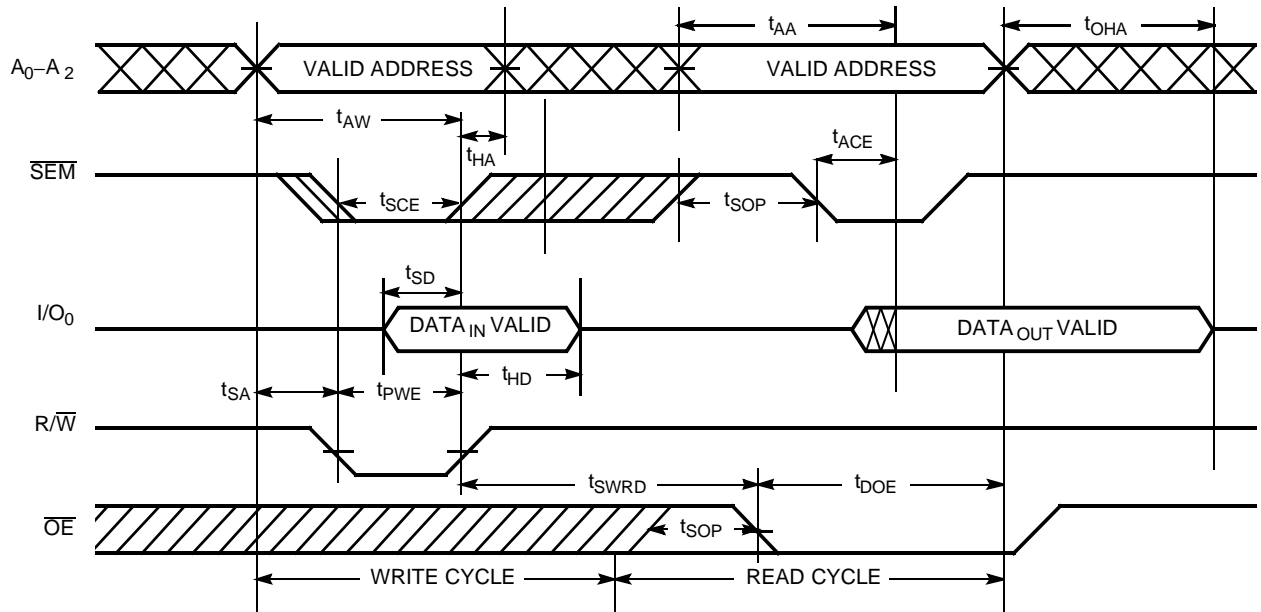
Notes:

21. The internal write time of the memory is defined by the overlap of \overline{CE} or \overline{SEM} LOW and R/ \overline{W} LOW. Both signals must be LOW to initiate a write, and either signal can terminate a write by going HIGH. The data input set-up and hold timing should be referenced to the rising edge of the signal that terminates the write.
22. If \overline{OE} is LOW during a R/ \overline{W} controlled write cycle, the write pulse width must be the larger of t_{PWE} or $(t_{HZWE} + t_{SD})$ to allow the I/O drivers to turn off and data to be placed on the bus for the required t_{SD} . If \overline{OE} is HIGH during a R/ \overline{W} controlled write cycle (as in this example), this requirement does not apply and the write pulse can be as short as the specified t_{PWE} .
23. R/ \overline{W} must be HIGH during all address transitions.
24. Data I/O pins enter high impedance when \overline{OE} is held LOW during write.

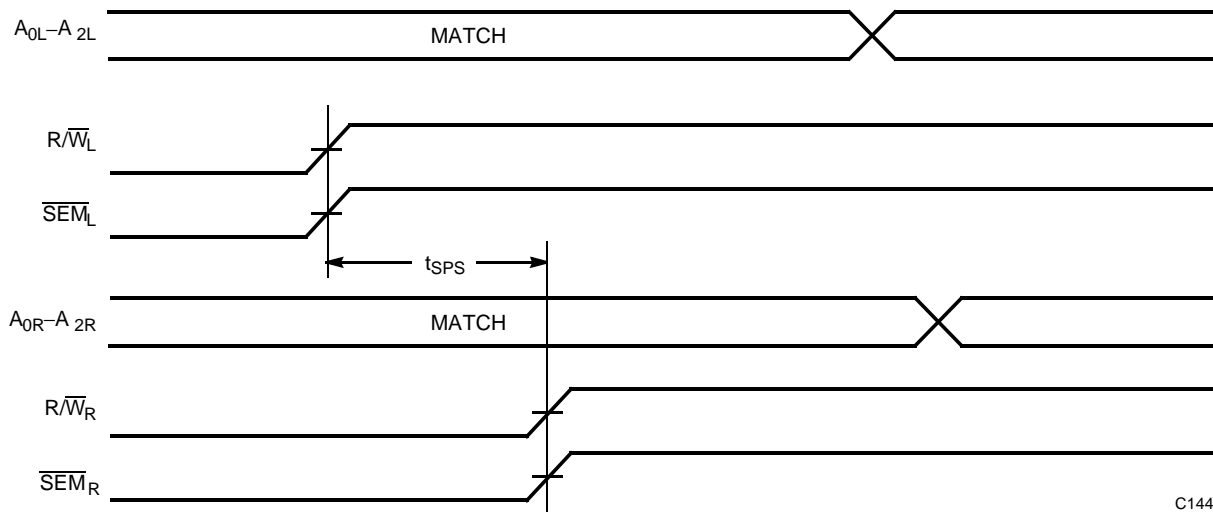
Switching Waveforms (continued)
Semaphore Read After Write Timing, Either Side^[25]

C144-15

Semaphore Contention^[26, 27, 28]

C144-16

Notes:

25. $\overline{CE} = \text{HIGH}$ for the duration of the above timing (both write and read cycle).
26. $I/O_{OR} = I/O_{OL} = \text{LOW}$ (request semaphore); $\overline{CE}_R = \overline{CE}_L = \text{HIGH}$
27. Semaphores are reset (available to both ports) at cycle start.
28. If t_{SPS} is violated, the semaphore will definitely be obtained by one side or the other, but there is no guarantee which side will control the semaphore.

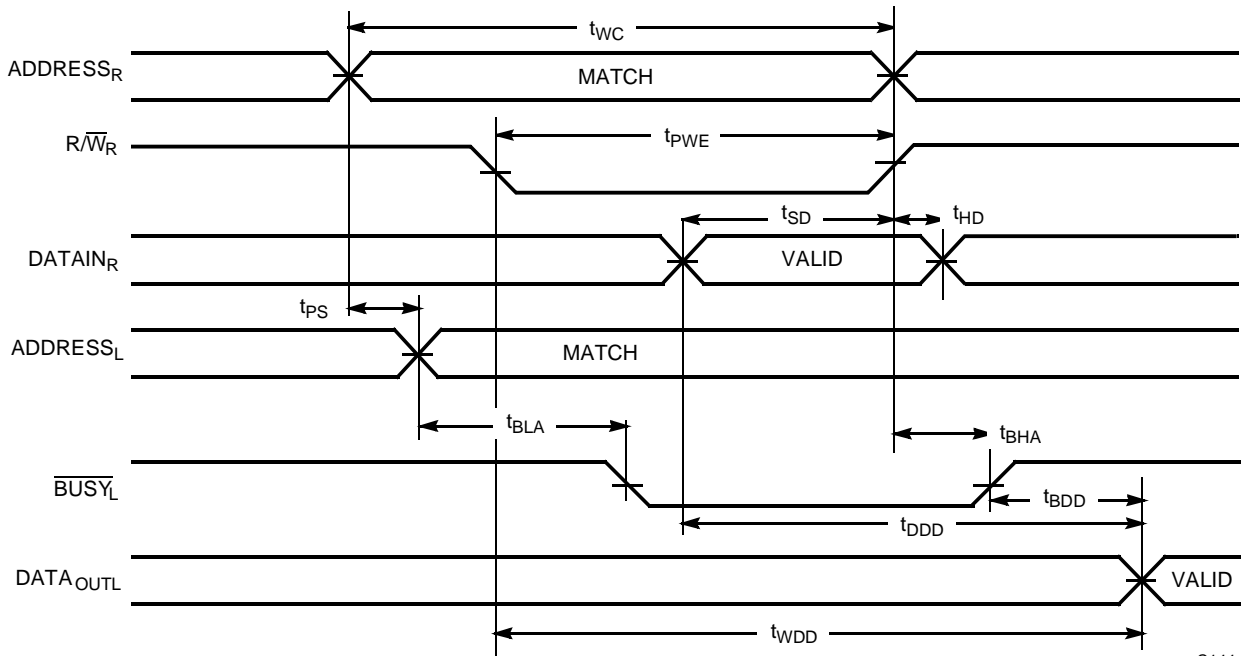
Switching Waveforms (continued)
Read with $\overline{\text{BUSY}}$ ($\text{M}/\overline{\text{S}}=\text{HIGH}$)^[20]

C144-17

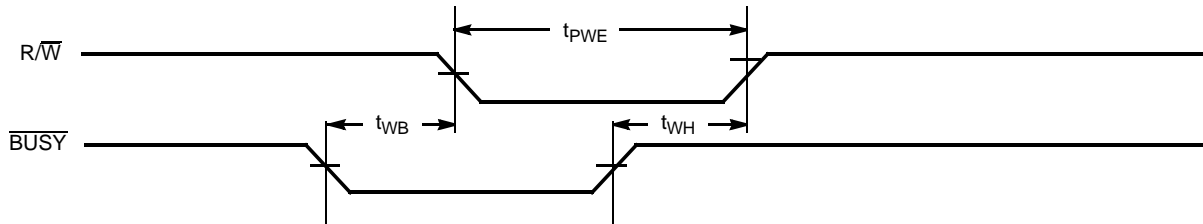
Write Timing with Busy Input ($\text{M}/\overline{\text{S}}=\text{LOW}$)

C144-18

Switching Waveforms (continued)

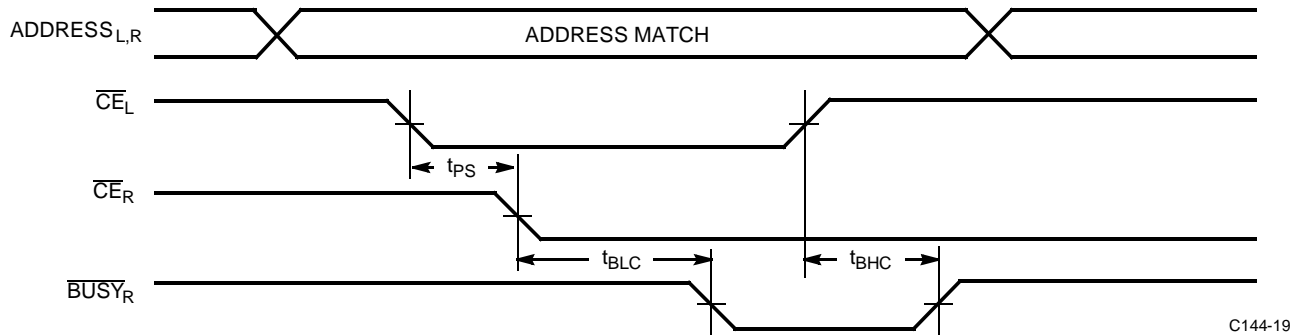
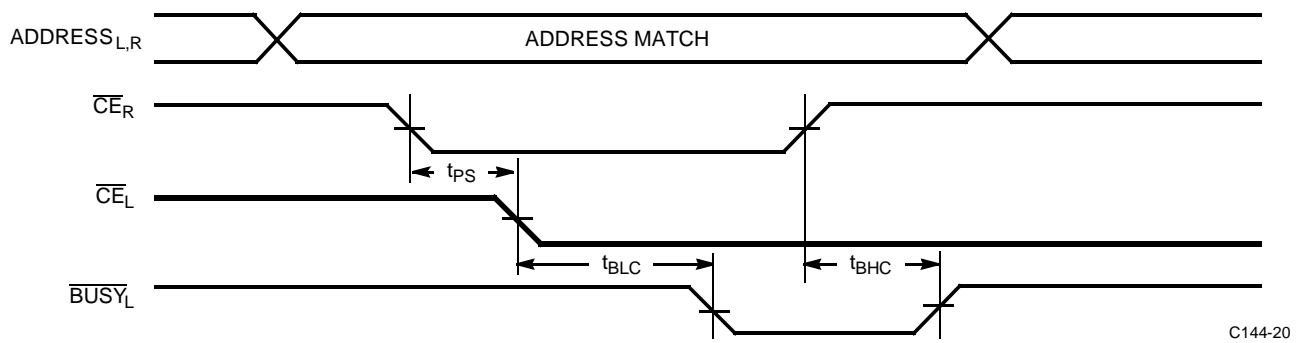
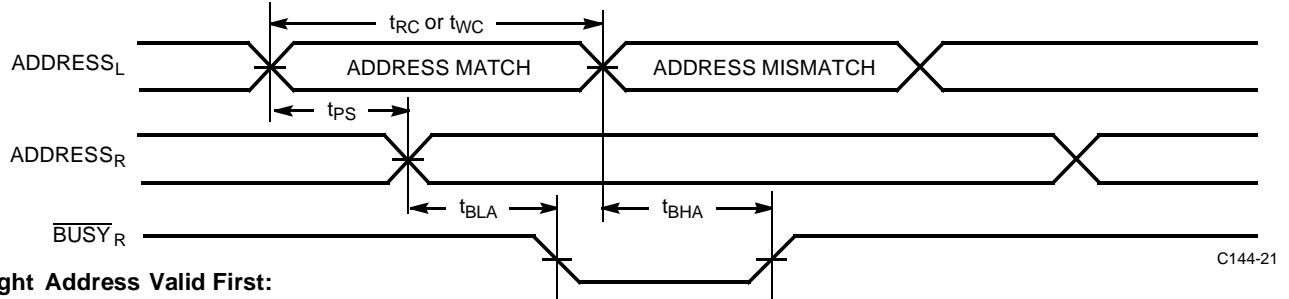
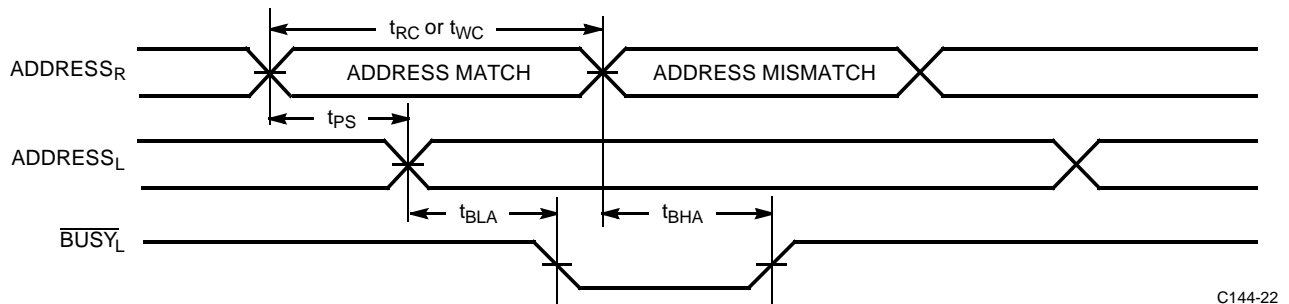
Busy Timing Diagram No. 1 (\overline{CE} Arbitration)^[29]
 \overline{CE}_L Valid First:

 \overline{CE}_R Valid First:

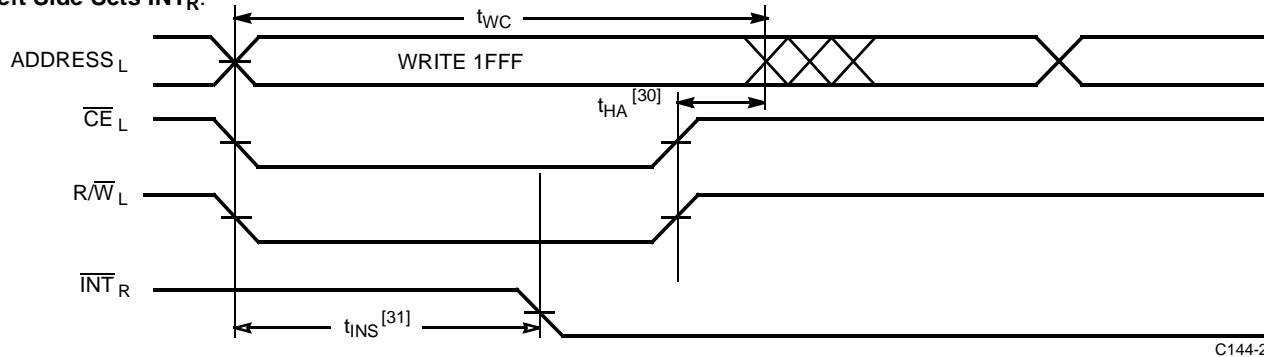
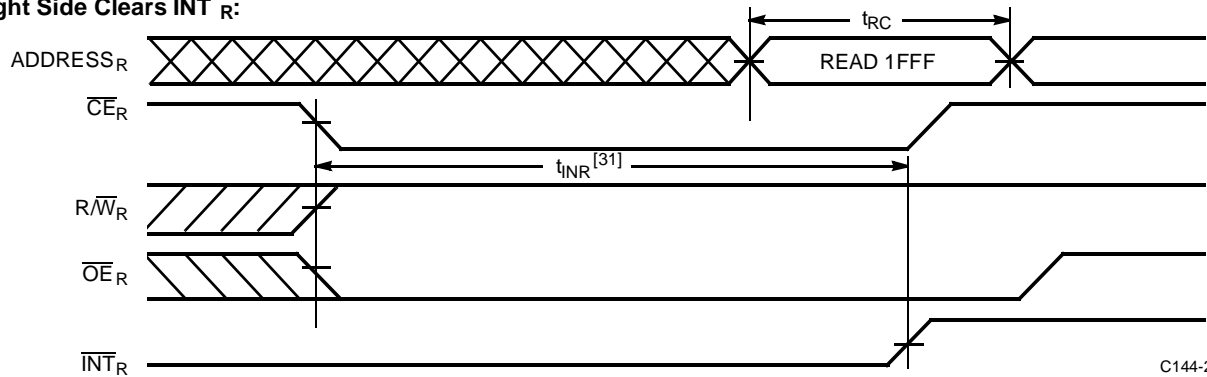
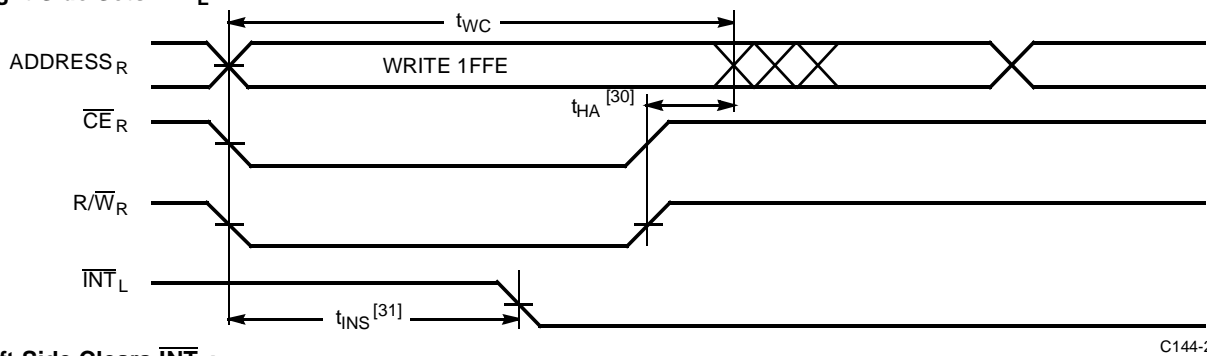
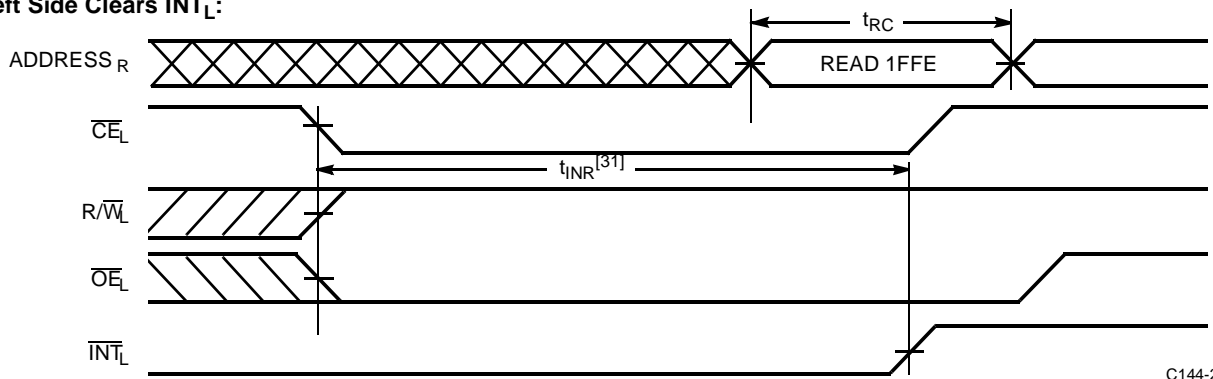
Busy Timing Diagram No. 2 (Address Arbitration)^[29]
Left Address Valid First:

Right Address Valid First:

Note:

29. If t_{PS} is violated, the busy signal will be asserted on one side or the other, but there is no guarantee on which side \overline{BUSY} will be asserted

Switching Waveforms (continued)
Interrupt Timing Diagrams
Left Side Sets $\overline{\text{INT}}_R$:

Right Side Clears $\overline{\text{INT}}_R$:

Right Side Sets $\overline{\text{INT}}_L$:

Left Side Clears $\overline{\text{INT}}_L$:

Notes:

30. t_{HA} depends on which enable pin ($\overline{\text{CE}}_L$ or $\overline{\text{R/W}}_L$) is deasserted first.
 31. t_{INS} or t_{INR} depends on which enable pin ($\overline{\text{CE}}_L$ or $\overline{\text{R/W}}_L$) is asserted last.

Architecture

The CY7C144/5 consists of an array of 8K words of 8/9 bits each of dual-port RAM cells, I/O and address lines, and control signals (\overline{CE} , \overline{OE} , R/\overline{W}). These control pins permit independent access for reads or writes to any location in memory. To handle simultaneous writes/reads to the same location, a \overline{BUSY} pin is provided on each port. Two interrupt (\overline{INT}) pins can be utilized for port-to-port communication. Two semaphore (\overline{SEM}) control pins are used for allocating shared resources. With the M/\overline{S} pin, the CY7C144/5 can function as a Master (\overline{BUSY} pins are outputs) or as a slave (\overline{BUSY} pins are inputs). The CY7C144/5 has an automatic power-down feature controlled by \overline{CE} . Each port is provided with its own output enable control (\overline{OE}), which allows data to be read from the device.

Functional Description

Write Operation

Data must be set up for a duration of t_{SD} before the rising edge of R/\overline{W} in order to guarantee a valid write. A write operation is controlled by either the \overline{OE} pin (see Write Cycle No. 1 waveform) or the R/\overline{W} pin (see Write Cycle No. 2 waveform). Data can be written to the device t_{HZOE} after the \overline{OE} is deasserted or t_{HZWE} after the falling edge of R/\overline{W} . Required inputs for non-contention operations are summarized in *Table 1*.

If a location is being written to by one port and the opposite port attempts to read that location, a port-to-port flowthrough delay must be met before the data is read on the output; otherwise the data read is not deterministic. Data will be valid on the port t_{DDD} after the data is presented on the other port.

Read Operation

When reading the device, the user must assert both the \overline{OE} and \overline{CE} pins. Data will be available t_{ACE} after \overline{CE} or t_{DOE} after \overline{OE} are asserted. If the user of the CY7C144/5 wishes to access a semaphore flag, then the \overline{SEM} pin must be asserted instead of the \overline{CE} pin.

Interrupts

The interrupt flag (\overline{INT}) permits communications between ports. When the left port writes to location 1FFF, the right port's interrupt flag (\overline{INT}_R) is set. This flag is cleared when the right port reads that same location. Setting the left port's interrupt flag (\overline{INT}_L) is accomplished when the right port writes to location 1FFE. This flag is cleared when the left port reads location 1FFE. The message at 1FFF or 1FFE is user-defined. See *Table 2* for input requirements for \overline{INT} . \overline{INT}_R and \overline{INT}_L are push-pull outputs and do not require pull-up resistors to operate.

Busy

The CY7C144/5 provides on-chip arbitration to alleviate simultaneous memory location access (contention). If both ports' \overline{CE} s are asserted and an address match occurs within t_{PS} of each other the Busy logic will determine which port has access. If t_{PS} is violated, one port will definitely gain permission to the location, but it is not guaranteed which one. \overline{BUSY} will be asserted t_{BLA} after an address match or t_{BLC} after \overline{CE} is taken LOW. \overline{BUSY}_L and \overline{BUSY}_R

in master mode are push-pull outputs and do not require pull-up resistors to operate.

Master/Slave

An M/\overline{S} pin is provided in order to expand the word width by configuring the device as either a master or a slave. The \overline{BUSY} output of the master is connected to the \overline{BUSY} input of the slave. This will allow the device to interface to a master device with no external components. Writing of slave devices must be delayed until after the \overline{BUSY} input has settled. Otherwise, the slave chip may begin a write cycle during a contention situation. When presented a HIGH input, the M/\overline{S} pin allows the device to be used as a master and therefore the \overline{BUSY} line is an output. \overline{BUSY} can then be used to send the arbitration outcome to a slave.

Semaphore Operation

The CY7C144/5 provides eight semaphore latches which are separate from the dual-port memory locations. Semaphores are used to reserve resources that are shared between the two ports. The state of the semaphore indicates that a resource is in use. For example, if the left port wants to request a given resource, it sets a latch by writing a 0 to a semaphore location. The left port then verifies its success in setting the latch by reading it. After writing to the semaphore, \overline{SEM} or \overline{OE} must be deasserted for t_{SOP} before attempting to read the semaphore. The semaphore value will be available $t_{SWRD} + t_{DOE}$ after the rising edge of the semaphore write. If the left port was successful (reads a 0), it assumes control over the shared resource, otherwise (reads a 1) it assumes the right port has control and continues to poll the semaphore. When the right side has relinquished control of the semaphore (by writing a 1), the left side will succeed in gaining control of the semaphore. If the left side no longer requires the semaphore, a 1 is written to cancel its request.

Semaphores are accessed by asserting \overline{SEM} LOW. The \overline{SEM} pin functions as a chip enable for the semaphore latches (\overline{CE} must remain HIGH during \overline{SEM} LOW). A_{0-2} represents the semaphore address. \overline{OE} and R/\overline{W} are used in the same manner as a normal memory access. When writing or reading a semaphore, the other address pins have no effect.

When writing to the semaphore, only I/O_0 is used. If a 0 is written to the left port of an unused semaphore, a 1 will appear at the same semaphore address on the right port. That semaphore can now only be modified by the side showing 0 (the left port in this case). If the left port now relinquishes control by writing a 1 to the semaphore, the semaphore will be set to 1 for both sides. However, if the right port had requested the semaphore (written a 0) while the left port had control, the right port would immediately own the semaphore as soon as the left port released it. *Table 3* shows sample semaphore operations.

When reading a semaphore, all eight/nine data lines output the semaphore value. The read value is latched in an output register to prevent the semaphore from changing state during a write from the other port. If both ports attempt to access the semaphore within t_{SPS} of each other, the semaphore will definitely be obtained by one side or the other, but there is no guarantee which side will control the semaphore.

Initialization of the semaphore is not automatic and must be reset during initialization program at power-up. All Semaphores on both sides should have a one written into them at initialization from both sides to assure that they will be free when needed.

Table 1. Non-Contending Read/Write

Inputs				Outputs	Operation
\overline{CE}	R/W	\overline{OE}	\overline{SEM}	I/O _{0-7/8}	
H	X	X	H	High Z	Power-Down
H	H	L	L	Data Out	Read Data in Semaphore
X	X	H	X	High Z	I/O Lines Disabled
H		X	L	Data In	Write to Semaphore
L	H	L	H	Data Out	Read
L	L	X	H	Data In	Write
L	X	X	L		Illegal Condition

Table 2. Interrupt Operation Example (assumes $\overline{BUSY}_L = \overline{BUSY}_R = \text{HIGH}$)

Function	Left Port					Right Port				
	R/W	\overline{CE}	\overline{OE}	A ₀₋₁₂	\overline{INT}	R/W	\overline{CE}	\overline{OE}	A ₀₋₁₂	\overline{INT}
Set Left \overline{INT}	X	X	X	X	L	L	L	X	1FFE	X
Reset Left \overline{INT}	X	L	L	1FFE	H	X	L	L	X	X
Set Right \overline{INT}	L	L	X	1FFF	X	X	X	X	X	L
Reset Right \overline{INT}	X	X	X	X	X	X	L	L	1FFF	H

Table 3. Semaphore Operation Example

Function	I/O _{0-7/8} Left	I/O _{0-7/8} Right	Status
No action	1	1	Semaphore free
Left port writes semaphore	0	1	Left port obtains semaphore
Right port writes 0 to semaphore	0	1	Right side is denied access
Left port writes 1 to semaphore	1	0	Right port is granted access to semaphore
Left port writes 0 to semaphore	1	0	No change. Left port is denied access
Right port writes 1 to semaphore	0	1	Left port obtains semaphore
Left port writes 1 to semaphore	1	1	No port accessing semaphore address
Right port writes 0 to semaphore	1	0	Right port obtains semaphore
Right port writes 1 to semaphore	1	1	No port accessing semaphore
Left port writes 0 to semaphore	0	1	Left port obtains semaphore
Left port writes 1 to semaphore	1	1	No port accessing semaphore

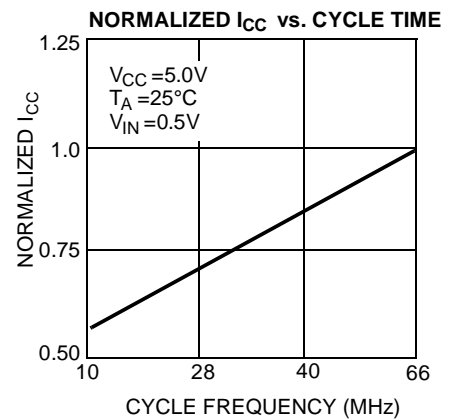
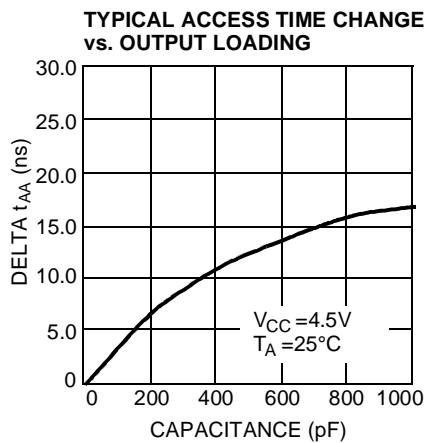
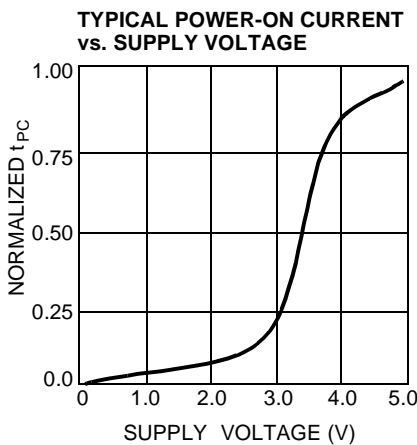
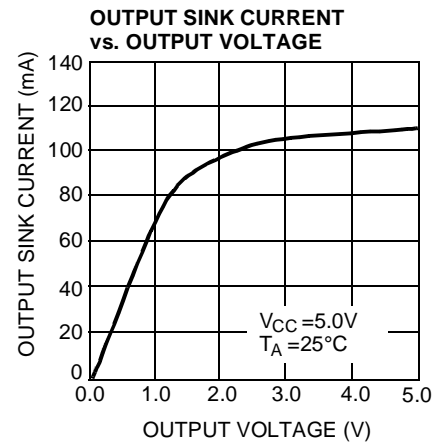
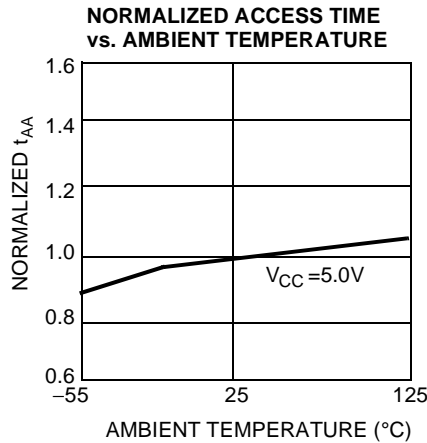
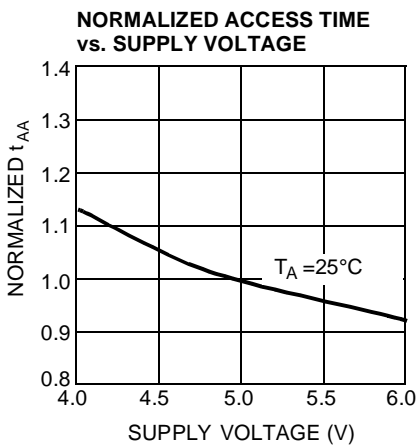
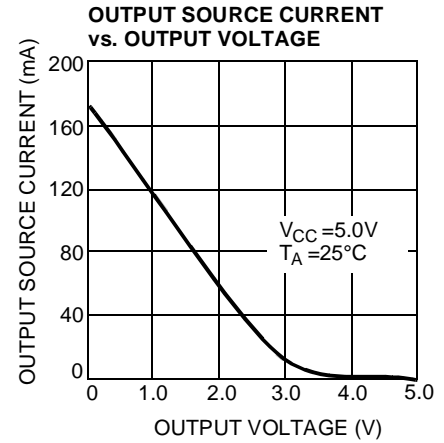
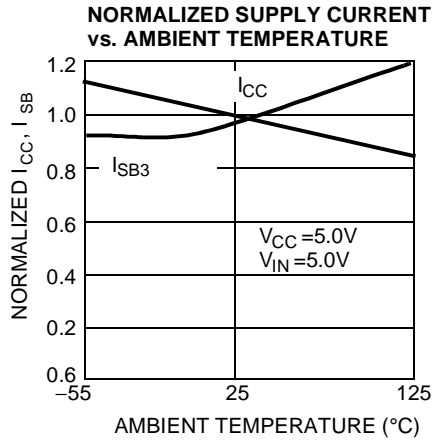
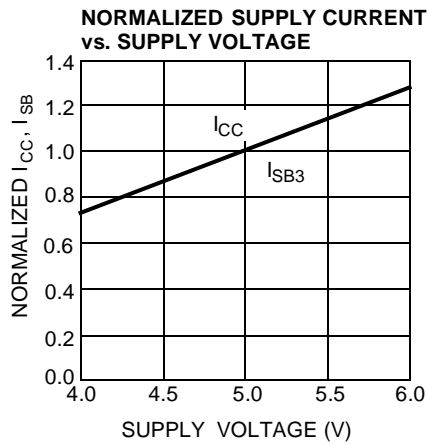
Typical DC and AC Characteristics

Ordering Information
8K x8 Dual-Port SRAM

Speed (ns)	Ordering Code	Package Name	Package Type	Operating Range
15	CY7C144-15AC	A65	64-Lead Thin Quad Flat Pack	Commercial
	CY7C144-15JC	J81	68-Lead Plastic Leaded Chip Carrier	
25	CY7C144-25AC	A65	64-Lead Thin Quad Flat Pack	Commercial
	CY7C144-25JC	J81	68-Lead Plastic Leaded Chip Carrier	
	CY7C144-25AI	A65	64-Lead Thin Quad Flat Pack	Industrial
	CY7C144-25JI	J81	68-Lead Plastic Leaded Chip Carrier	
35	CY7C144-35AC	A65	64-Lead Thin Quad Flat Pack	Commercial
	CY7C144-35JC	J81	68-Lead Plastic Leaded Chip Carrier	
	CY7C144-35AI	A65	64-Lead Thin Quad Flat Pack	Industrial
	CY7C144-35JI	J81	68-Lead Plastic Leaded Chip Carrier	
55	CY7C144-55AC	A65	64-Lead Thin Quad Flat Pack	Commercial
	CY7C144-55JC	J81	68-Lead Plastic Leaded Chip Carrier	
	CY7C144-55AI	A65	64-Lead Thin Quad Flat Pack	Industrial
	CY7C144-55JI	J81	68-Lead Plastic Leaded Chip Carrier	

8K x9 Dual-Port SRAM

Speed (ns)	Ordering Code	Package Name	Package Type	Operating Range
15	CY7C145-15AC	A80	80-Lead Thin Quad Flat Pack	Commercial
	CY7C145-15JC	J81	68-Lead Plastic Leaded Chip Carrier	
25	CY7C145-25AC	A80	80-Lead Thin Quad Flat Pack	Commercial
	CY7C145-25JC	J81	68-Lead Plastic Leaded Chip Carrier	
	CY7C145-25AI	A80	80-Lead Thin Quad Flat Pack	Industrial
	CY7C145-25JI	J81	68-Lead Plastic Leaded Chip Carrier	
35	CY7C145-35AC	A80	80-Lead Thin Quad Flat Pack	Commercial
	CY7C145-35JC	J81	68-Lead Plastic Leaded Chip Carrier	
	CY7C145-35AI	A80	80-Lead Thin Quad Flat Pack	Industrial
	CY7C145-35JI	J81	68-Lead Plastic Leaded Chip Carrier	
55	CY7C145-55AC	A80	80-Lead Thin Quad Flat Pack	Commercial
	CY7C145-55JC	J81	68-Lead Plastic Leaded Chip Carrier	
	CY7C145-55AI	A80	80-Lead Thin Quad Flat Pack	Industrial
	CY7C145-55JI	J81	68-Lead Plastic Leaded Chip Carrier	

Document #: 38-00163

Package Diagrams

64-Pin Thin Plastic Quad Flat Pack A65

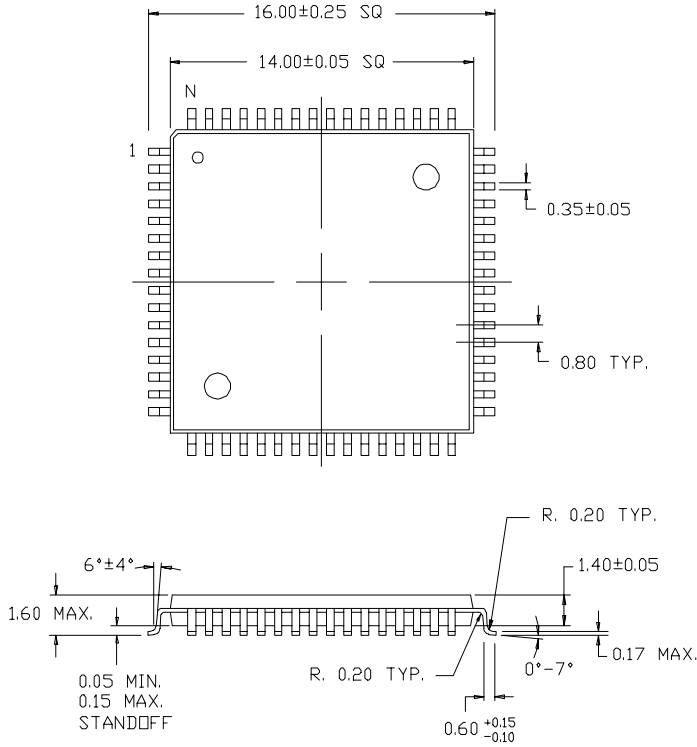

80-Pin Thin Plastic Quad Flat Pack A80

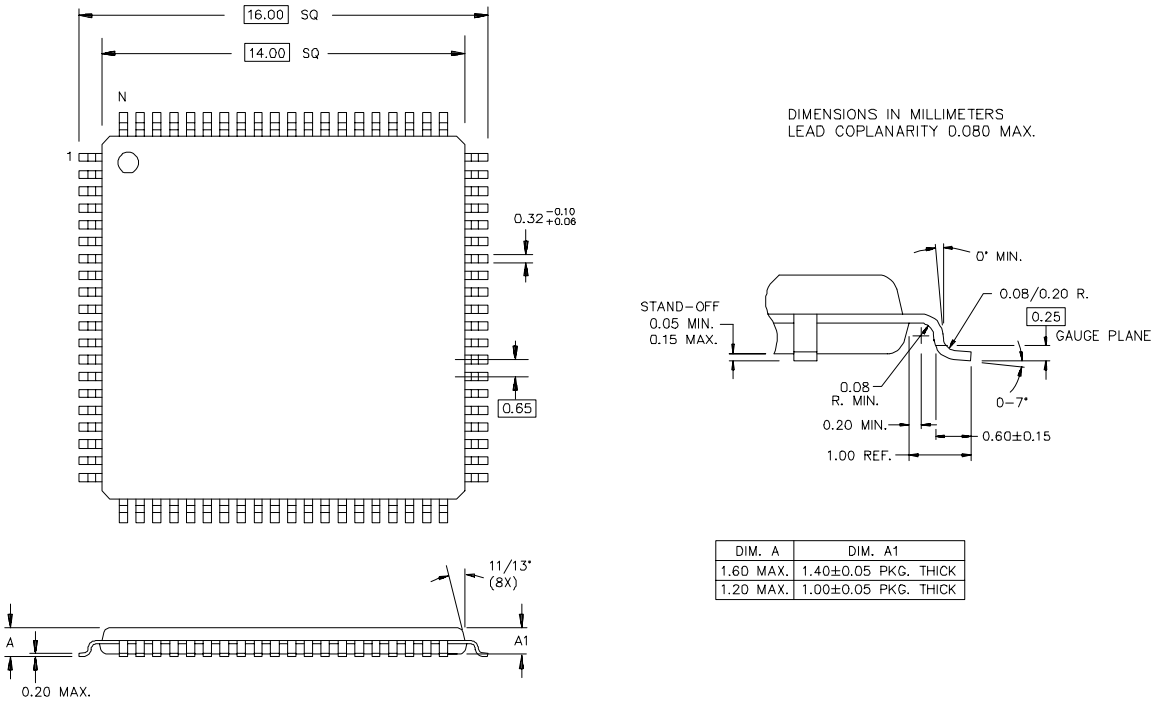

Package Diagrams (continued)

68-Lead Plastic Leaded Chip Carrier J81

