

HD46508, HD46508-1, HD46508A, HD46508A-1 ADU (Analog Data Acquisition Unit)

The HD46508 is a monolithic NMOS device with a 10-bit analog-to-digital converter, a programmable voltage comparator, a 16-channel analog multiplexer and HMCS6800 microprocessor family compatible interface.

Each of 16 analog inputs is either converted to a digital data by the analog-to-digital converter or compared with the specified value by the programmable comparator. The analog-to-digital converter uses successive approximation method as the conversion technique. Its intrinsic resolution is 10 bits but it can be 8 bits if the programmer so desires. The programmable voltage comparator compares the input voltage with the value specified by the programmer. The result (greater than, or smaller than) is reflected to the flag in the status register.

The device can expand its capability by controlling the external circuits such as sample holder, pre-amplifier and external multiplexer.

With these features, this device is ideally suited to applications such as process control, machine control and vehicle control.

■ FEATURES

- 16-channel Analog multiplexer
- Programmable A/D Converter resolution (10-bit or 8-bit)
- Programmable Voltage comparison (PC)
- Conversion Time 100 μ s (A/D), 13 μ s(PC)
- External Sample and Hold Circuit Control
- Auto Range-switching Control of External Amplifier
- Waiting Function for the Settling Time of External Amplifier
- Interrupt Control (Only for A/D conversion)
- Single +5V Power Supply
- Compatible with HMCS6800 Bus (The connection with other Asynchronous Buses possible)

■ BLOCK DIAGRAM

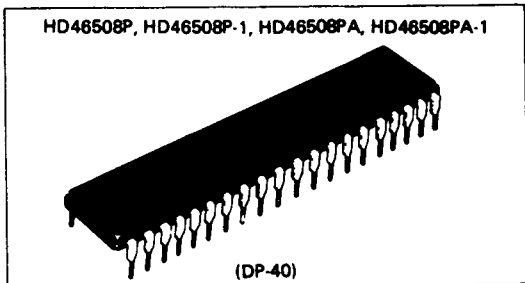
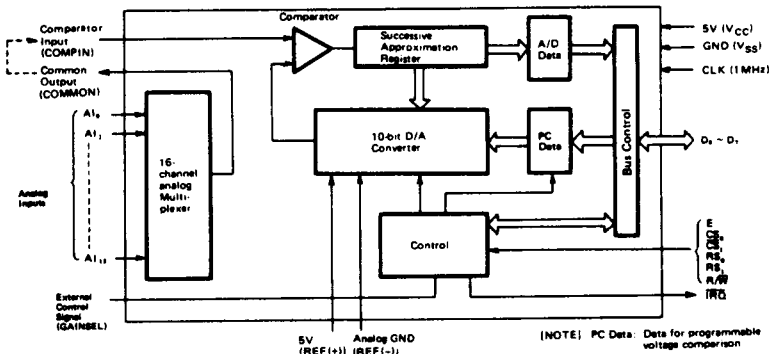

■ PIN ARRANGEMENT

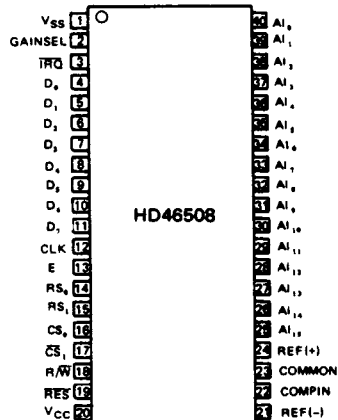

(Top View)

■ ORDERING INFORMATION

ADU	Bus Timing	Non Linearity*
HD46508A	1 MHz	± 1 LSB
HD46508A-1	1.5 MHz	
HD46508A-2	2 MHz	
HD46508	1 MHz	± 3 LSB
HD46508-1	1.5 MHz	
HD46508-2	2 MHz	

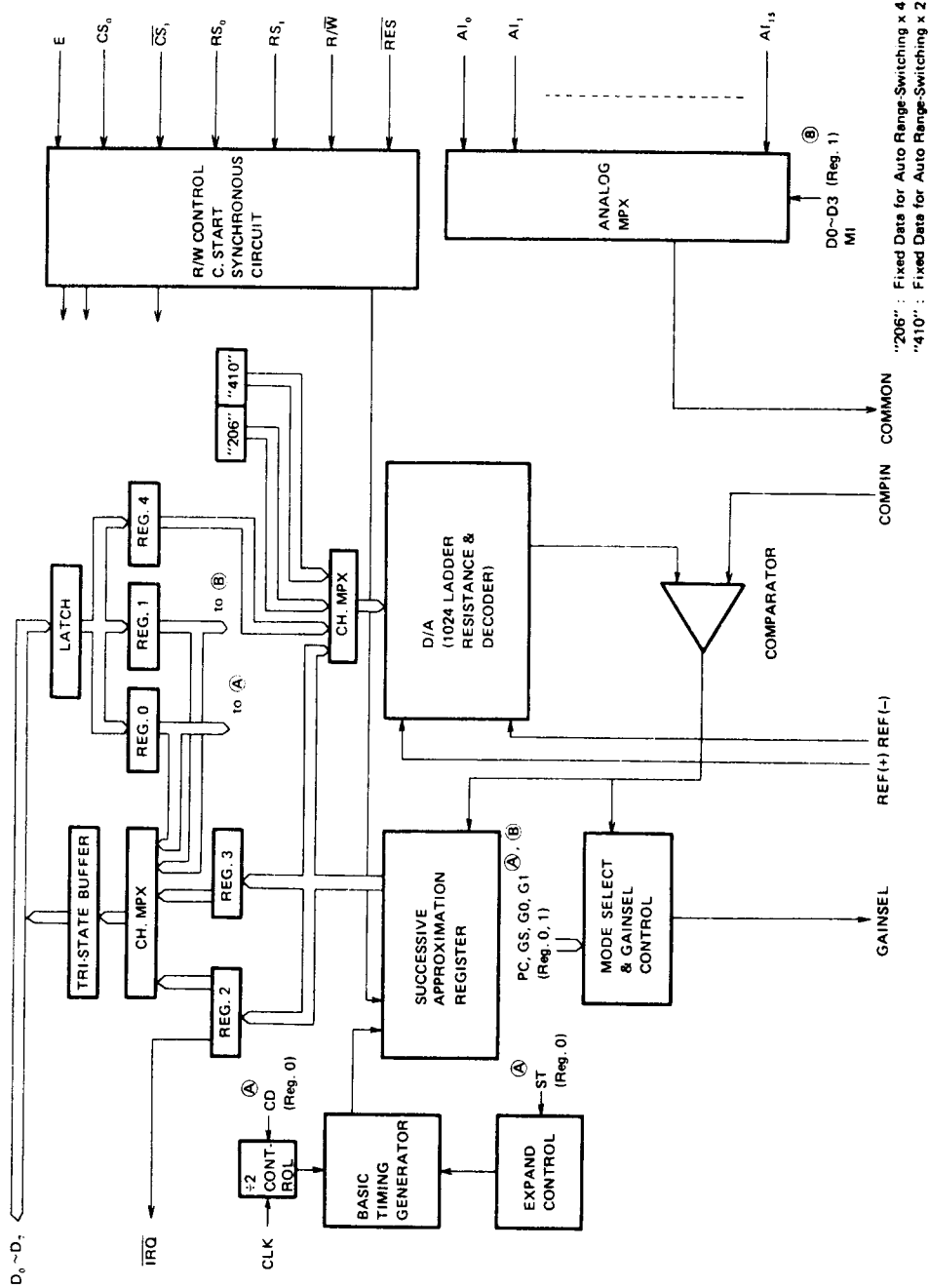

"206" : Fixed Data for Auto Range-Switching x 4
 "410" : Fixed Data for Auto Range-Switching x 2

Figure 1 Internal Block Diagram



HD46508, HD46508-1, HD46508A, HD46508A-1

■ ABSOLUTE MAXIMUM RATINGS

Item	Symbol	Value	Unit
Supply Voltage	V_{CC}^*	-0.3 ~ +7.0	V
Input Voltage	V_{in}^*	-0.3 ~ +7.0	V
Analog Input Voltage	V_{Ain}^*	-0.3 ~ +7.0	V
Operating Temperature	T_{opr}	-20 ~ +75	°C
Storage Temperature	T_{stg}	-55 ~ +150	°C

* With respect to V_{SS} (SYSTEM GND)

[NOTE] Permanent LSI damage may occur if maximum ratings are exceeded. Normal operation should be under recommended operating conditions. If these conditions are exceeded, it could affect reliability of LSI.

■ RECOMMENDED OPERATING CONDITIONS

Item	Symbol	min	typ	max	Unit
Supply Voltage	V_{CC}^*	4.75	5.0	5.25	V
Input "High" Voltage	V_{IH}^*	2.0	-	V_{CC}	V
Input "Low" Voltage	V_{IL}^*	-0.3	-	0.8	V
Analog Input Voltage	V_{Ain}^*	0	-	$V_{REF(+)}$	V
Reference Voltage	$V_{REF(+)}^*$	-	V_{CC}	$V_{CC}+0.25$	V
	$V_{REF(-)}^*$	-0.1	0	-	
Voltage Center of Ladder	$\frac{V_{REF(+)} + V_{REF(-)}}{2}$	-	$\frac{V_{CC}}{2}$	$\frac{V_{CC}+0.25}{2}$	V
Operating Temperature	T_{opr}	-20	25	75	°C

*With respect to V_{SS} (SYSTEM GND)

■ ELECTRICAL CHARACTERISTICS

● DC CHARACTERISTICS <1> ($V_{CC} = 5V \pm 5\%$, $V_{SS} = 0V$, $T_a = -20 \sim +75^\circ C$, unless otherwise noted.)

Item	Symbol	Test Condition	min	typ	max	Unit	
Input "High" Voltage	V_{IH}		2.0	-	V_{CC}	V	
Input "Low" Voltage	V_{IL}		-0.3	-	0.8	V	
Output "High" Voltage	$D_0 \sim D_7$ GAINSEL	V_{OH}	$I_{OH} = -205\mu A$	2.4	-	-	V
			$I_{OH} = -200\mu A$	2.4	-	-	
			$I_{OH} = -10\mu A$	$V_{CC}-1.0$	-	-	
Output "Low" Voltage	$D_0 \sim D_7, \text{GAINSEL}$ \overline{IRQ}	V_{OL}	$I_{OL} = 1.6 \text{ mA}$	-	-	0.4	V
			$I_{OL} = 3.2 \text{ mA}$	-	-	0.4	
Input Leakage Current	I_{in}	$V_{in} = 0 \sim 5.25V$ E, CLK, R/W RES, RS ₀ , RS ₁ CS ₀ , CS ₁	-2.5	-	2.5	μA	
Three-State (off state) Input Current	I_{TSI}	$D_0 \sim D_7$ $V_{in} = 0.4 \sim 2.4V$	-10	-	10	μA	
Output Leakage Current	I_{LOH}	\overline{IRQ} $V_{OH} = 2.4V$	-	-	10	μA	
Power Dissipation	P_D		-	-	500	mW	
Input Capacitance	$D_0 \sim D_7$ E, CLK, R/W RES, RS ₀ , RS ₁ CS ₀ , CS ₁	C_{in}	$V_{in} = 0V, T_a = 25^\circ C$ $f = 1 \text{ MHz}$	-	-	12.5	pF
				-	-	10.0	
Output Capacitance	$\overline{IRQ}, \text{GAINSEL}$	C_{out}	$V_{in} = 0V, T_a = 25^\circ C$ $f = 1 \text{ MHz}$	-	-	10.0	pF

4



HD46508, HD46508-1, HD46508A, HD46508A-1

● DC CHARACTERISTICS <2> ($V_{CC} = 5V \pm 5\%$, $V_{SS} = 0V$, $T_a = -20 \sim +75^\circ C$, unless otherwise noted.)

Item	Test Condition	min	typ	max	Unit
Analog Multiplexer ON Resistance	$V_{Ain} = 5.0V$, $V_{CC} = 4.75V$, $T_a = 25^\circ C$	—	—	1	k Ω
OFF Channel Leakage Current	$V_{Ain} = 5.0V$ $V_{CC} = 4.75V$, $T_a = 25^\circ C$ COMMON = 0V	—	10	100	nA
	$V_{Ain} = 0V$, $T_a = 25^\circ C$ $V_{CC} = 4.75V$, COMMON = 5V	-100	-10	—	nA
Analog Multiplexer Input Capacitance		—	—	7.5	pF
Ladder Resistance (from REF(+) to REF(-))	$V_{REF(+)} = 5.0V$ $V_{REF(-)} = 0V$, $T_a = 25^\circ C$	10	—	40	k Ω

● CONVERTER SECTION ($T_a = 25^\circ C$, $V_{CC} = V_{REF(+)} = 5.0V$, $t_{CYC} = 1\mu s$, unless otherwise noted.)

1. 10-BIT A/D CONVERSION

Item	HD46508A, HD46508A-1			HD46508, HD46508-1			Unit
	min	typ	max	min	typ	max	
Resolution	—	10	—	—	10	—	bits
Non-linearity Error *	—	$\pm 1/2$	± 1	—	± 1	± 3	LSB
Zero-Error	—	$\pm 1/2$	$\pm 3/4$	—	$\pm 1/2$	± 1	LSB
Full-Scall Error	—	$\pm 1/4$	$\pm 1/2$	—	$\pm 1/2$	± 1	LSB
Quantization Error	—	—	$\pm 1/2$	—	—	$\pm 1/2$	LSB
Absolute Accuracy *	—	± 1	$\pm 3/2$	—	± 2	± 4	LSB

2. 8-BIT A/D CONVERSION

Item	HD46508A, HD46508A-1			HD46508, HD46508-1			Unit
	min	typ	max	min	typ	max	
Resolution	—	8	—	—	8	—	bits
Non-linearity Error *	—	$\pm 1/8$	$\pm 1/4$	—	$\pm 1/4$	$\pm 3/4$	LSB
Zero-Error	—	$\pm 1/4$	$\pm 3/8$	—	$\pm 3/8$	$\pm 1/2$	LSB
Full-Scall Error	—	$\pm 1/4$	$\pm 3/8$	—	$\pm 3/8$	$\pm 1/2$	LSB
Quantization Error	—	—	$\pm 1/2$	—	—	$\pm 1/2$	LSB
Absolute Accuracy *	—	$\pm 5/8$	$\pm 3/4$	—	$\pm 3/4$	$\pm 5/4$	LSB

3. PROGRAMMABLE VOLTAGE COMPARISON (PC)

Item	HD46508A, HD46508A-1			HD46508, HD46508-1			Unit
	min	typ	max	min	typ	max	
Resolution	—	8	—	—	8	—	bits
Non-linearity Error *	—	$\pm 1/8$	$\pm 1/4$	—	$\pm 1/4$	$\pm 3/4$	LSB
Zero-Error	—	$\pm 1/4$	$\pm 3/8$	—	$\pm 3/8$	$\pm 1/2$	LSB
Full-Scall Error	—	$\pm 1/4$	$\pm 3/8$	—	$\pm 3/8$	$\pm 1/2$	LSB
Absolute Accuracy *	—	$\pm 3/8$	$\pm 5/8$	—	$\pm 1/2$	± 1	LSB

*Temperature Coefficient; 25 ppm of FSR/ $^\circ C$ (max)

HD46508, HD46508-1, HD46508A, HD46508A-1

● AC CHARACTERISTICS ($V_{CC} = 5.0V \pm 5\%$, $V_{SS} = 0V$, $T_a = -20 \sim +75^\circ C$, unless otherwise noted.)

1. CLOCK WAVEFORM

Item	Symbol	Test Conditions	CD* = 0			CD* = 1			Unit
			min	typ	max	min	typ	max	
CLK Cycle Time	t_{cycC}	Fig. 2	1.0	—	10	0.5	—	5	μs
CLK "High" Pulse Width	PW_{CH}		0.45	—	4.5	0.22	—	2.2	μs
CLK "Low" Pulse Width	PW_{CL}		0.40	—	4.0	0.21	—	2.1	μs
Rise and Fall Time of CLK	t_{Cr}, t_{Cf}		—	—	25	—	—	25	ns

* CD : CLK Divider bit

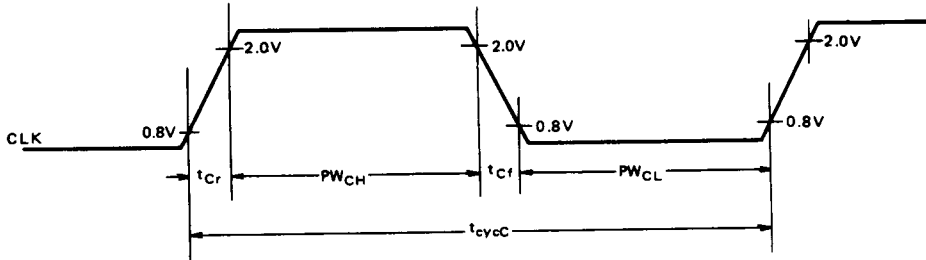

Figure 2 CLK Waveform

2. \overline{IRQ} , GAINSEL OUTPUT

Item	Symbol	Test condition	min	typ	max	Unit
\overline{IRQ} Release Time	t_{IR}	Fig. 3	—	—	750	ns
GAINSEL Delay Time	t_{GSD1}	Fig. 4	—	—	750	ns
	t_{GSD2}		—	—	750	ns

t_{GSD1} : TTL Load
 t_{GSD2} : CMOS Load

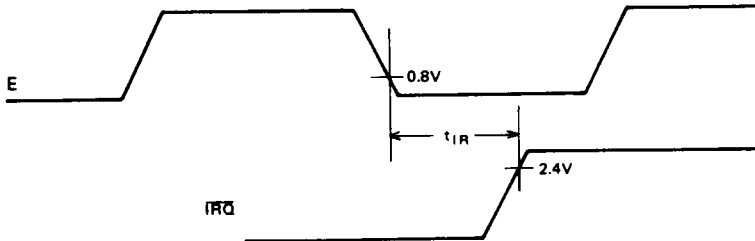
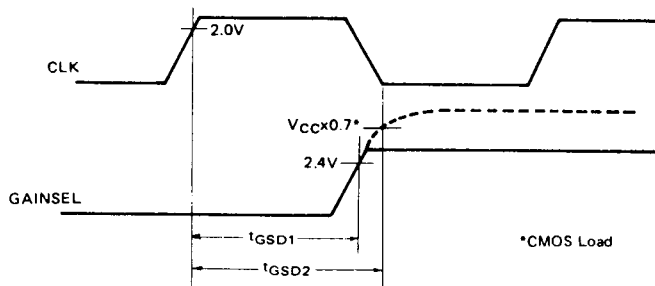

Figure 3 \overline{IRQ} Release Time



HD46508, HD46508-1, HD46508A, HD46508A-1

(1) Sample & Hold



(2) x2, x4 Auto Range-Switching, Programmable Gain

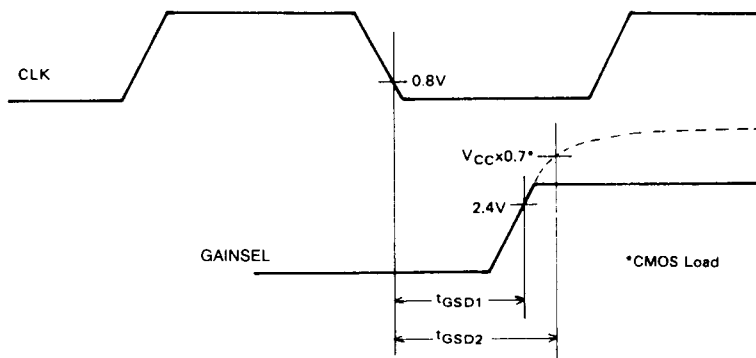

Figure 4 GAINSEL Delay Time

3. BUS TIMING CHARACTERISTICS

READ OPERATION SEQUENCE

Item	Symbol	Test Condition	HD46508 HD46508A			HD46508-1 HD46508A-1			Unit
			min	typ	max	min	typ	max	
Enable Cycle Time	t_{cycE}	Fig. 5	1.0	—	—	0.666	—	—	μs
Enable "High" Pulse Width	PW_{EH}		0.45	—	—	0.28	—	—	μs
Enable "Low" Pulse Width	PW_{EL}		0.40	—	—	0.28	—	—	μs
Rise and Fall Time of Enable	t_{Er}, t_{Ef}		—	—	25	—	—	25	ns
Address Set Up Time	t_{AS}		140	—	—	140	—	—	ns
Data Delay Time	t_{DDR}		—	—	320	—	—	220	ns
Data Access Time	t_{ACC}		—	—	460	—	—	360	ns
Data Hold Time	t_H		10	—	—	10	—	—	ns
Address Hold Time	t_{AH}		10	—	—	10	—	—	ns



HD46508, HD46508-1, HD46508A, HD46508A-1

WRITE OPERATION SEQUENCE

Item	Symbol	Test Condition	HD46508 HD46508A			HD46508-1 HD46508A-1			Unit
			min	typ	max	min	typ	max	
Enable Cycle Time	t_{cycE}	Fig. 6	1.0	—	—	0.666	—	—	μs
Enable "High" Pulse Width	PW_{EH}		0.45	—	—	0.280	—	—	μs
Enable "Low" Pulse Width	PW_{EL}		0.40	—	—	0.280	—	—	μs
Rise and Fall Time of Enable	t_{Er}, t_{Ef}		—	—	25	—	—	25	ns
Address Set Up Time	t_{AS}		140	—	—	140	—	—	ns
Data Set Up Time	t_{DSW}		195	—	—	80	—	—	ns
Data Hold Time	t_H		10	—	—	10	—	—	ns
Address Hold Time	t_{AH}		10	—	—	10	—	—	ns

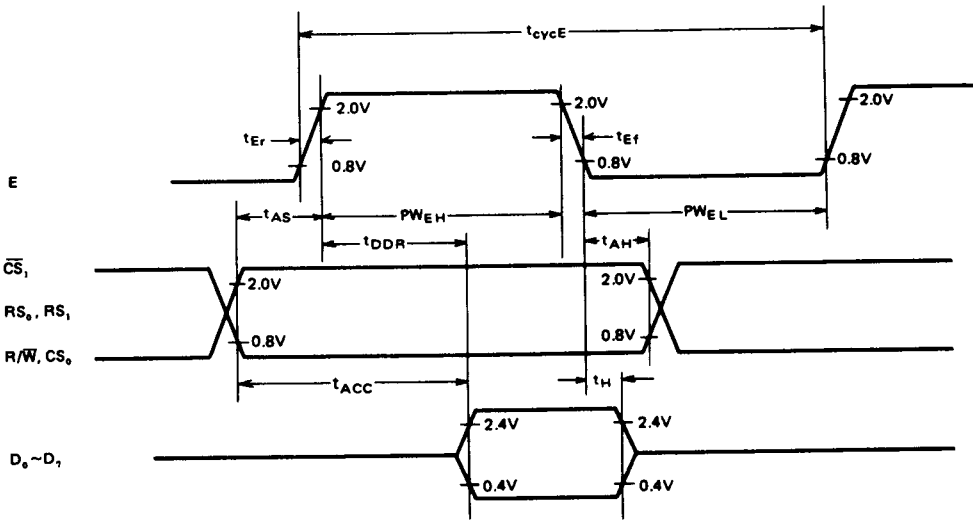

Figure 5 Read Timing



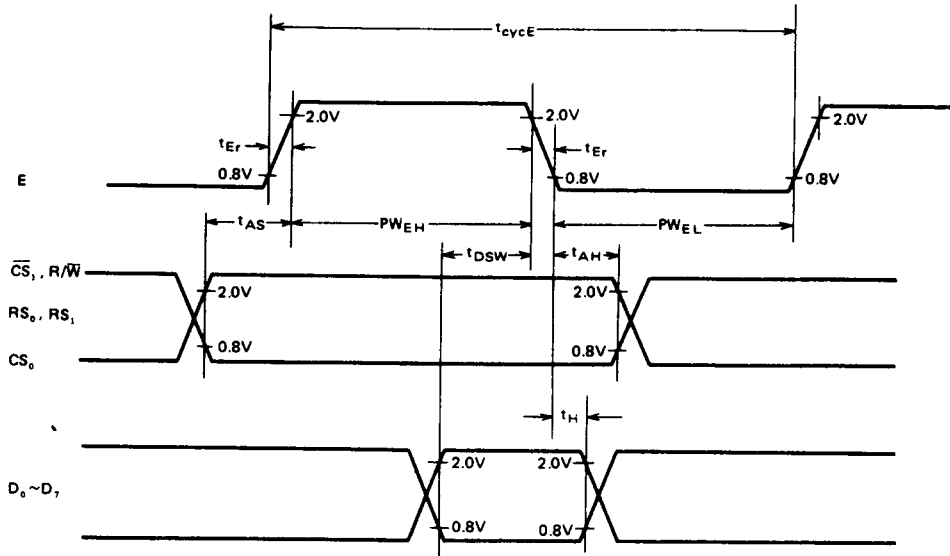

Figure 6 Write Timing

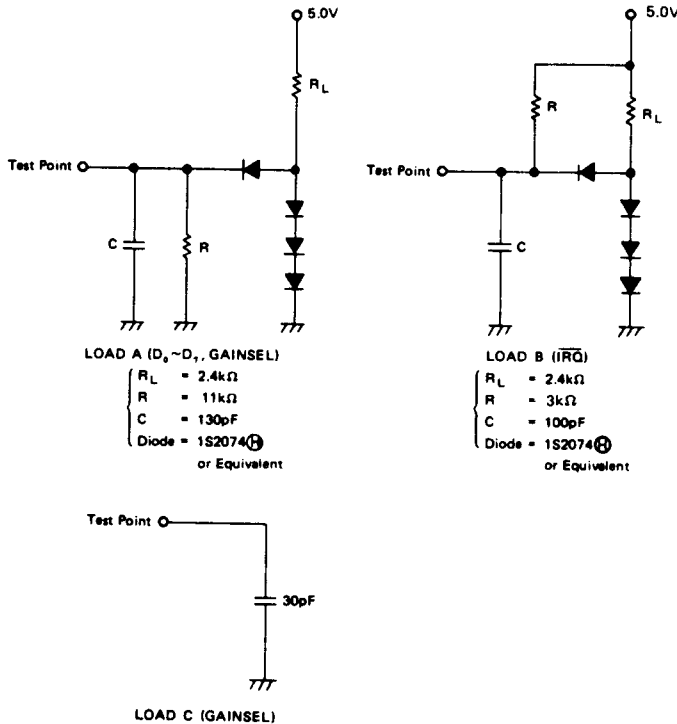

Figure 7 Test Load

■ SIGNAL DESCRIPTION

● Processor Interface

Data Bus (D₀~D₇)

The Bi-directional data lines (D₀~D₇) allow data transfer between the ADU and MPU. Data bus output drivers are three state buffers that remain in the high-impedance state except when MPU performs a ADU read operation.

Enable (E)

The Enable signal (E) is used as strobe signal in MPU R/W operation with the ADU internal registers. This signal is normally derived from the HMCS6800 system clock (φ₂).

Chip Select (CS₀, CS₁)

The Chip Select lines (CS₀, CS₁) are used to address the ADU. The ADU is selected when CS₀ is at "High" and CS₁ is at "Low" level.

Read/Write (R/W)

The R/W line controls the direction of data transfer between the ADU and MPU. When R/W is at "High" level, data of ADU is transferred to MPU. When R/W is at "Low" level, data of MPU is transferred to ADU.

Register Select (RS₀, RS₁)

The Register Select line (RS₀, RS₁) are used to select one of the 4 ADU internal registers. Table 1 shows the relation between (RS₀, RS₁) address and the selected register. The lowest 2 address lines of MPU are usually used for these signals.

Reset (RES)

This input is used to reset the ADU. An input "Low" level on RES line forces the ADU into following status.

- 1) All the shift-registers in ADU are cleared and the conversion operation is stopped.
- 2) The GAINSEL output goes down to "Low" level. The IRQ output is made "Off" state and the D₀~D₇ are made high impedance state.

Interrupt Request (IRQ) (Open Drain Output)

This output line is used to inform the A/D conversion end signal to the MPU. This signal becomes active "Low" level when IE bit in the control register 1 is "1" and IRQ bit in the control register 2 goes "1" at the end of conversion. And this signal returns to "High" right after The MPU reads the A/D Data Register (R3). Programmable voltage comparison

does not affect this signal.

● Analog Data Interface

Analog Input (AI₀~AI₁₅)

The Input Analog Data to be measured is applied to these Analog Input (AI₀~AI₁₅). These are multiplexed by internal 16 channel multiplexer and output to COMMOM pin. A particular input channel is selected when the multiplexer channel address is programmed into the control Register 1 (R1).

Multiplexer Common Output (COMMON)

This signal is the output of the 16 channel analog multiplexer, and may be connected to the input of pre-amplifier or sample/hold circuit according to user's purposes. When no external circuit needed, this output should be connected to the COMPIN input.

Comparator Input (COMPIN)

This is a high impedance input line that is used to transmit selected analog data to comparator. The COMMON line is usually connected to this input. When external Pre-amplifier or Sample/hold circuit is used, output of these circuits may be connected to this input.

Reference Voltage (+) (REF (+))

This line is used to apply the standard voltage to the internal ladder resistors.

Reference Voltage (-) (REF (-))

This line is connected to the analog ground.

● ADU Control

Conversion Clock (CLK)

The CLK is a standard clock input signals which defines internal timing for A/D conversion and PC operation.

Gain Select (GAINSEL) (CMOS Compatible Output)

This output is used to control the external circuit. The function of this signal is programmable and it is specified by (G1, G0) bits in Control Register 0. By using this output, user can control the auto-range-switching of external pre-amplifier, also control external sample & hold circuit, etc. as well.

[NOTE] This LSI is different from other HMCS6800 family LSIs in following function

- RES doesn't affect IE bit of R0

■ FUNCTION OF INTERNAL REGISTERS

● Structure

Table 1 Internal Registers of the ADU

CS ₁	CS ₀	RS ₁	RS ₀	Reg. #	Register Name	Read	Write	Data Bit								
								7	6	5	4	3	2	1	0	
0	1	0	0	R0	Control Register 0	○	○	IE	CD	ST					G1	G0
0	1	0	1	R1	Control Register 1	○	○	SC	GS	PC	MI	D3	D2	D1	D0	
0	1	1	0	R2	Status & A/D Data Register (H)	○	x	IRQ	BSY	PCO		OV	DW	C9	C8	
0	1	1	1	R3	A/D Data Register (L)	○	x	C7	C6	C5	C4	C3	C2	C1	C0	
0	1	1	1	R4	PC Data Register	x	○	B7	B6	B5	B4	B3	B2	B1	B0	

(Note) ○ --- YES
x --- NO

HD46508, HD46508-1, HD46508A, HD46508A-1

Control Register 0 (R0)



	"1"	"0"
Mode Select	See Table 2	
Not Used		
Not Used		
Not Used		
Settling Time	Available	Not Available
CLK Divider	CLK/2	CLK
Interrupt Enable*	Enable IRQ	Mask IRQ

Figure 8 Control Register 0

*RES doesn't affect IE bit.

Control Register 1 (R1)

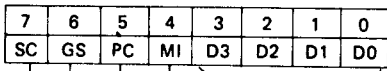

	"1"	"0"
MPX Channel Address	See Table 3	
MPX Inhibit	Inhibited	Not Inhibited
Prog. Comparator Select	Prog. Comparator mode	A/D Converter mode
GAINSEL Enable	GAINSEL Enable	GAINSEL Disable
Short-cycle Conversion	8-bit Length	10-bit Length

Figure 9 Control Register 1

Status & A/D Data Register (H)

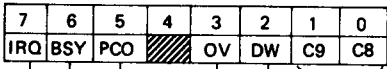

	"1"	"0"
Upper bit (10 bit data)		
Data Weight	See Table 4.	
Data Over Scale flag	Data is over scale	Within the scale
Not Used		
Programmable Comparator Output	$V_{Ain} > V_p$	$V_{Ain} < V_p$
Busy flag	Under Conversion	Conversion Completed
IRQ flag	Requested	Not Requested

V_{Ain} : Unknown Input Voltage

V_p : Programmed Voltage by R4

C9, C8 bits are cleared when 8 bit A/D conversion is performed.

Figure 10 Status & A/D Data Register (H)

A/D Data Register (L)

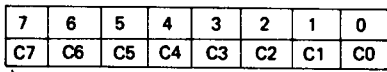

Lower order 8 bit Data (Normal 10 bit Conversion)
8 bit Data (8 bit Short-cycle Conversion)

Figure 11 A/D Data Register (L)



PC Data Register

7	6	5	4	3	2	1	0
B7	B6	B5	B4	B3	B2	B1	B0

8 bit Data for Programmable Voltage Comparison

Figure 12 PC Data Register

● **Description for the Internal Registers**

Control Register 0 (R0)

This Register is a 5-bit read/write register that is used to specify Interrupt Enable (IE), CLK Divider (CD), Settling Time (ST) and Mode Select (G0, G1). This Register should be written before writing R1.

- IE bit: (Interrupt Enable)
 - IE = "1", Interrupt is requested through the IRQ output.
 - IE = "0", Interrupt is masked.
- CD bit: (Clock Divider)
 - CD = "1", CLK ÷ 2 is used as internal clock.
 - CD = "0", CLK is used directly.
- ST bit: (Settling Time)
 - ST = "1", First comparison is executed after 1 expanded cycle in order to compensate external amplifiers settling delay.
 - ST = "0", Cycle is not delayed.
- G0, G1 bit: (Mode select)
 - These bits are used to specify the function of GAINSEL signal when GS bit is "1"

Table 2 Function of G0, G1

G1	G0	Mode Select
0	0	Sample & Hold
0	1	Auto Range-Switching x 2
1	0	Auto Range-Switching x 4
1	1	Programmable Gain Control

Control Register 1 (R1)

This register is an 8-bit read/write register that is used to store the command for A/D conversion mode and programmable comparison mode. This register includes MPX channel address (D0~D3), MPX inhibit (MI), programmable comparator select (PC), GAINSEL enable (GS) and short-cycle conversion (SC) bits. When this register (R1) is programmed, each conversion mode starts.

- SC bit (Short-cycle)
 - SC = "1", Short-cycle conversion (8 bit length)
 - SC = "0", Normal conversion (10 bit length)
- GS bit (GAINSEL Enable)
 - GS = "1", GAINSEL signal is enabled. The function of GAINSEL is specified by (G0, G1) bits.
 - GS = "0", GAINSEL signal is disabled. ("Low" level)
- PC bit (Program comparator)
 - PC = "1", Programmable voltage comparator mode
 - PC = "0", A/D conversion mode
- MI bit (MPX Inhibit)
 - MI = "1", Internal MPX channel is inhibited in order to use external MPX channel.
 - MI = "0", Internal MPX channel is used.
- D0~D3 (MPX channel)
 - These bits are used to select the particular MPX channel.

Table 3 MPX Channel Addressing

Channel #1	D3	D2	D1	D0	Analog Input
0	0	0	0	0	AI ₀
1	0	0	0	1	AI ₁
2	0	0	1	0	AI ₂
3	0	0	1	1	AI ₃
4	0	1	0	0	AI ₄
5	0	1	0	1	AI ₅
6	0	1	1	0	AI ₆
7	0	1	1	1	AI ₇
8	1	0	0	0	AI ₈
9	1	0	0	1	AI ₉
10	1	0	1	0	AI ₁₀
11	1	0	1	1	AI ₁₁
12	1	1	0	0	AI ₁₂
13	1	1	0	1	AI ₁₃
14	1	1	1	0	AI ₁₄
15	1	1	1	1	AI ₁₅



HD46508, HD46508-1, HD46508A, HD46508A-1

Table 4 Function Select

PC	SC	Function	GS	(G0, G1)
0	0	10 bit AD CONV.	0	DISABLE
			1	ENABLE*
	1	8 bit AD CONV.	0	DISABLE
			1	ENABLE*
1	x	PROG. COMP (8 bit)	x	DISABLE

x = Do not care

* = See Table 6

[NOTE] CD bit and ST bit are effective in every case.

Status & A/D Data Register (H) (R2)

This register is a 7-bit read only register that is used to store the upper 2-bit data (C8, C9), data weight (DW), data overscale (OV), programmable comparator output (PCO), busy (BSY) and interrupt request (IRQ).

(C8, C9) : These bits store upper 2-bit data measured by 10 bit length conversion.

DW bit (Data weight) : This bit indicates data weight when Auto range-switching mode is selected. This bit is set or reset when the conversion has completed. The conditions are shown in following Table. In this mode GAINSEL output also goes "High" or "Low" on the same condition shown in Table 5. Other status of DW bit is shown in Table 6.

OV bit (Over scale) : This bit is set when analog data is greater than or equal to reference Voltage ($V_{REF(+)}$).

PCO bit (Programmable comparator Output) : This bit indicates the result of programmable voltage comparison.
 "1" → PCO $V_{Ain} > V_p$
 "0" → PCO $V_{Ain} < V_p$
 V_{Ain} : Analog Input Voltage to be compared
 V_p : Programmed Voltage (R4)

BSY bit (Busy) : This bit indicates that the ADU is now under conversion.

IRQ bit (Interrupt Request) : This bit is set when the A/D conversion has completed and cleared by reading the R3.

A/D Data Register (L) (R3)

This register is an 8-bit read-only register that is used to store the lower 8 bits data of 10-bit conversion or full 8 bits data of the 8-bit conversion.

PC Data Register (R4)

This register is an 8-bit write-only register prepared for Programmable Voltage comparison. Stored data is converted to digital voltage, and compared with analog input to be measured. The result of comparison is set into PCO bit.

Table 5 Data Weight (DW) Set or Reset Condition

Mode \ Condition	Set ("1")	Reset ("0")
Auto Range-Switching (x2)	$V_{Ain} < \frac{410}{1024} \cdot V_{REF(+)}$	$V_{Ain} > \frac{410}{1024} \cdot V_{REF(+)}$
Auto Range-Switching (x4)	$V_{Ain} < \frac{206}{1024} \cdot V_{REF(+)}$	$V_{Ain} > \frac{206}{1024} \cdot V_{REF(+)}$

V_{Ain} : Analog Input Voltage to be measured

$V_{REF(+)}$: Voltage Applied to REF(+)



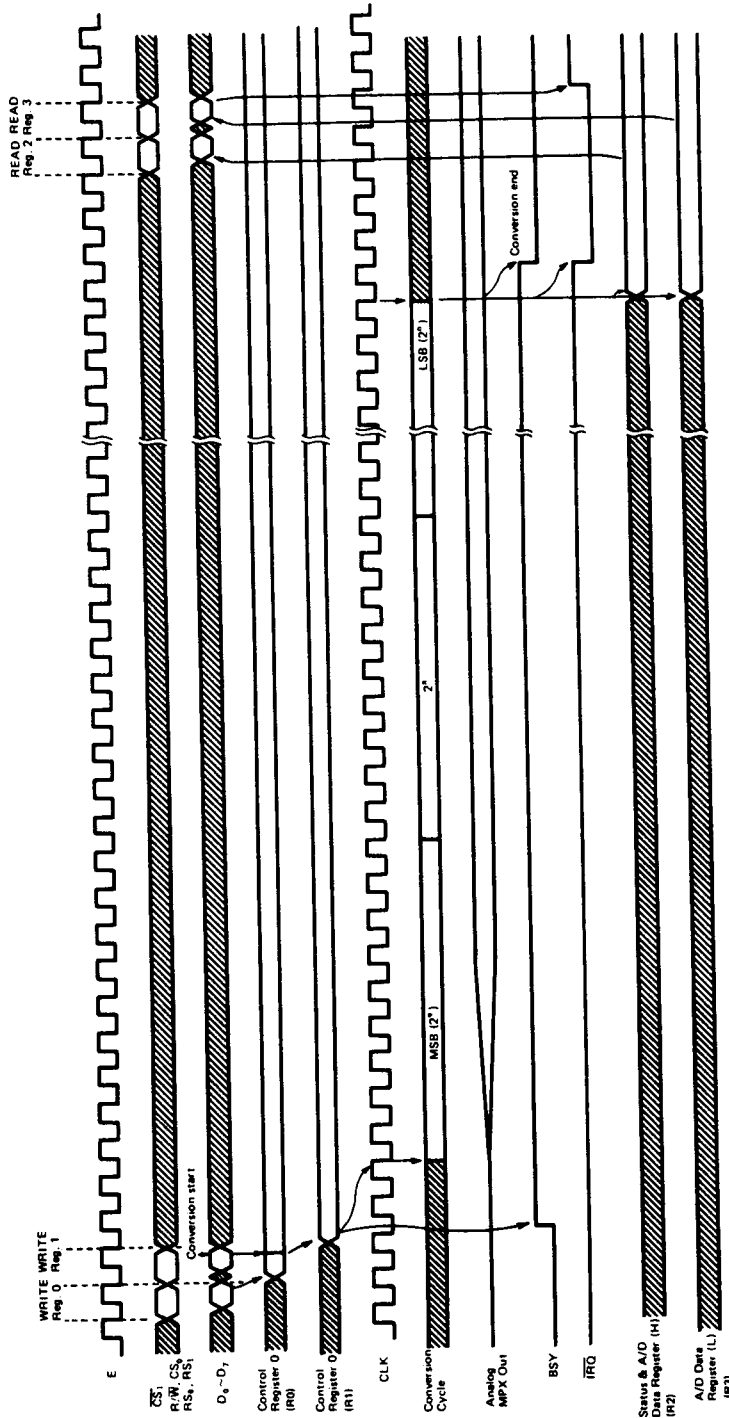

Figure 13 A/D Conversion Timing Chart (Basic Sequence)

HD46508, HD46508-1, HD46508A, HD46508A-1

• A/D Conversion and PC sequence ($t_{cyc}=1\mu s$)

10 bits A/D Conversion

1) Basic Sequence

(SC = "0"
ST = "0"
GS = "0")

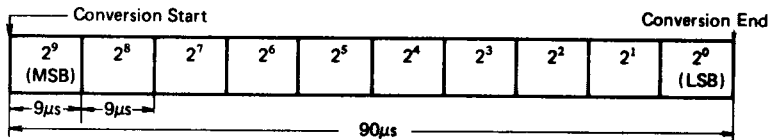

2) Basic Sequence (When overscale is detected)

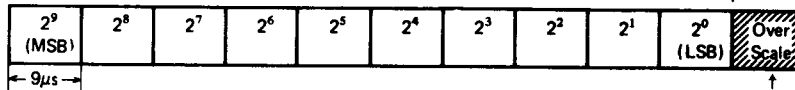

↑
Overscale check Cycle
(Analog Input is compared with $V_{REF(+)}$.)

3) Expanded Sequence

(SC = "0"
ST = "1"
GS = "0")

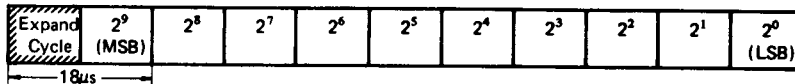

MSB cycle is expanded to compensate external amplifier's settling delay.

4) Auto Range-Switching Control Sequence

{ SC = "0"
ST = "0"
GS = "1"
G0 = "0"
G1 = "1"
or
G0 = "1"
G1 = "0"

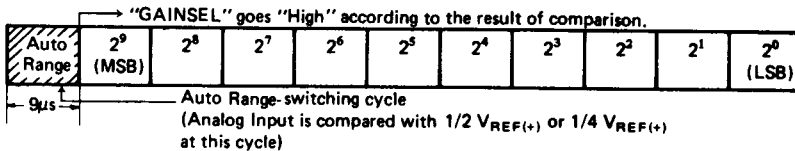

5) Auto Range-Switching & Expansion Control Sequence

{ SC = "0"
ST = "1"
GS = "1"
G0 = "0"
G1 = "1"
or
G0 = "1"
G1 = "0"

a) Analog Input $< 1/2 V_{REF(+)}$ or $1/4 V_{REF(+)}$

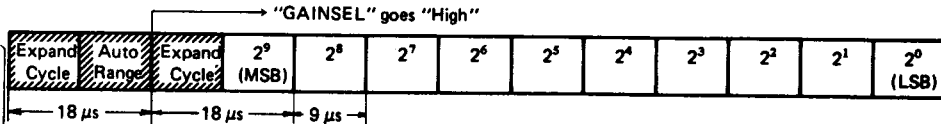

b) Analog Input $> 1/2 V_{REF(+)}$ or $1/4 V_{REF(+)}$

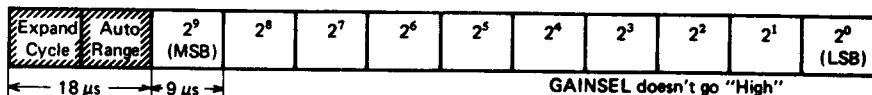

6) Sample & Hold Control Sequence

(SC = "0"
ST = "0"
GS = "1"
G0 = "0"
G1 = "0")

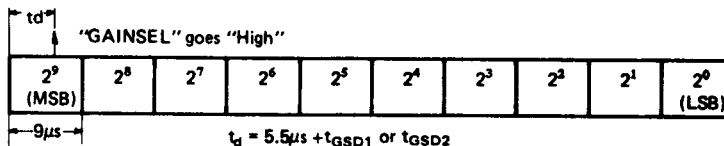

7) Programmable Gain Control Sequence

SC = "0"
 ST = "0"
 GS = "1"
 G0 = "1"
 G1 = "1"

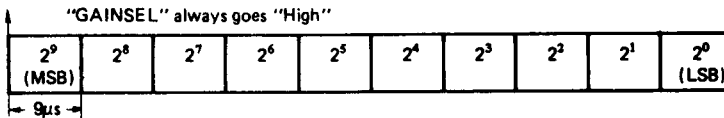

8) Programmable Gain & Expansion Control Sequence

SC = "0"
 ST = "1"
 GS = "1"
 G0 = "1"
 G1 = "1"

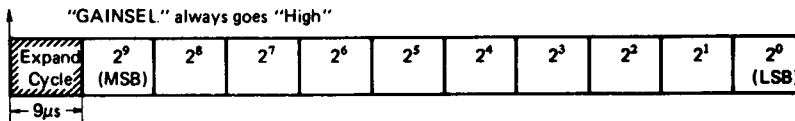

8 Bit A/D Conversion

1) Basic Sequence

SC = "1"
 ST = "0"
 GS = "0"

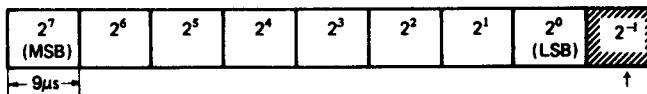

Additional conversion cycle for rounding the LSB - 1 Bit.

2) Expanded Sequence

SC = "1"
 ST = "1"
 GS = "0"

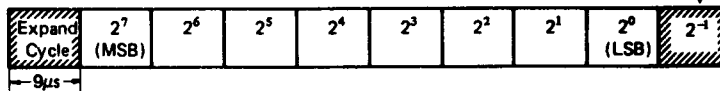

Programmable Voltage Comparison

1) Basic Sequence

PC = "1"
 ST = "0"



2) Expanded Sequence

PC = "1"
 ST = "1"

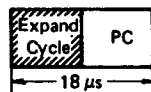

HOW TO USE THE ADU

Functions of GAINSEL

The ADU is equipped with programmable GAINSEL output signal. By using GAINSEL output and external circuit, the ADU is able to implement following control.

- 1) Auto Range-Switching (Auto Gain) Control
 - 2) Programmable Gain control
 - 3) Sample & Hold control
- GAINSEL output is controlled by Mode Select bit (G0, G1) when GAINSEL enable bit (GS) is "1".

Table 6 GAINSEL Control

GS	G1	G0	GAINSEL	Control Mode	DW
0	x	x	"Low"	Normal Use (GAINSEL is not used)	0
1	0	0	"High"	Sample & Hold control	0
1	0	1	*	Auto Range Switching x 2 control	**
1	1	0	*	Auto Range Switching x 4 control	**
1	1	1	"High"	Programmable Gain control	1

* GAINSEL goes "High" or "Low" according to the condition shown in Table 5.
 ** See, Table 5.

● **Usage of the PC**

The ADU has a programmable threshold voltage comparator (PC) function. The threshold voltage is pre-settable from 0V to 5V range with 8 bit resolution. The comparator's

output is stored into PCO bit at the end of comparision.

The programmable voltage comparison time is so short that the interrupt is not requested at this mode. The end of comparison needs to be confirmed by reading the 1→0 transition of the BSY bit in R2.

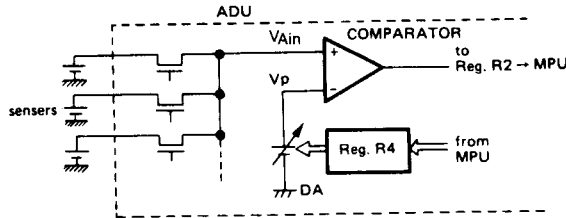

Figure 18 Function Diagram of the PC

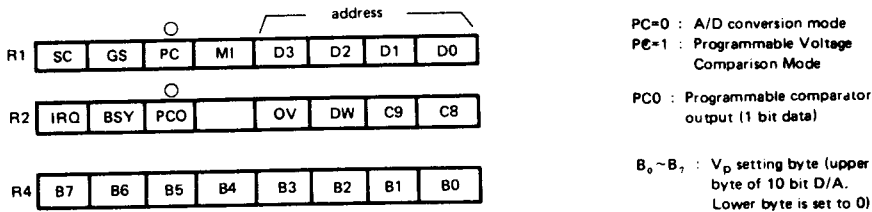

Figure 19 Registers of the PC Mode

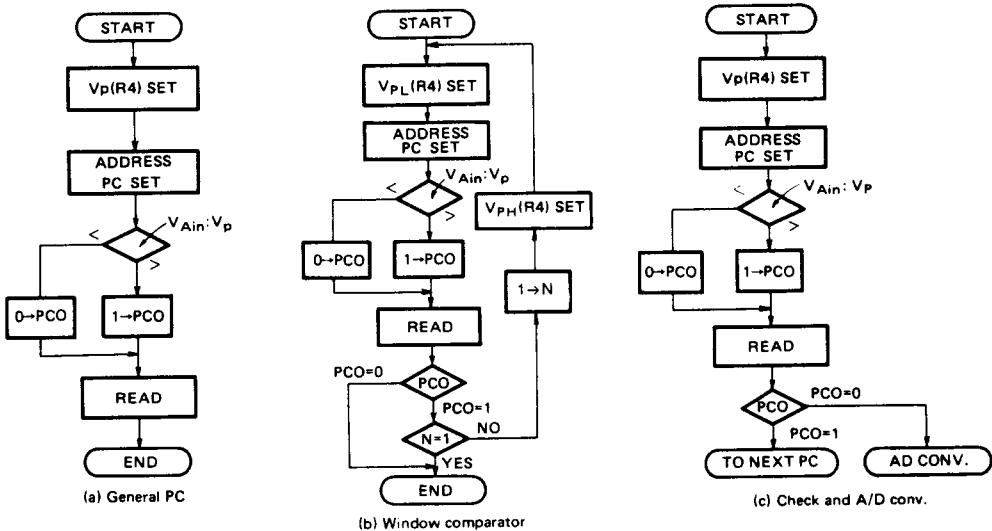
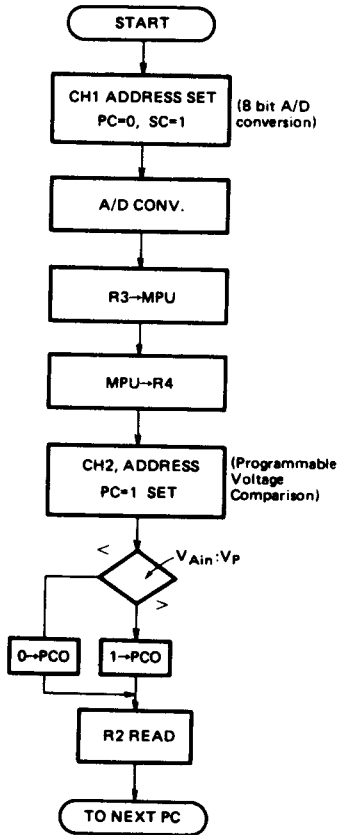

Figure 20 PC Application Flow Chart Examples





(d) Voltage Comparison between two channels.

Figure 20 PC Application Flow Chart Examples (continued)

■ EXAMPLE OF APPLIED CIRCUIT OF THE ADU

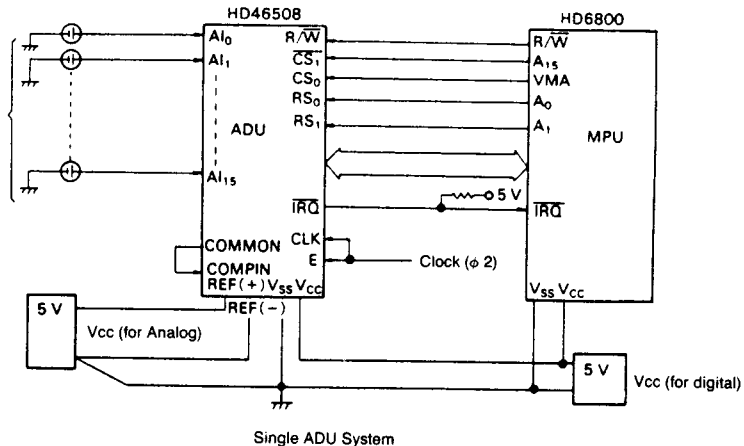

• How to use MI bit

MI bit (R1) functions as follows.

- MI = 1: Internal MPX channel is inhibited in order to use attached external MPX channel.
- MI = 0: Internal MPX channel is enabled.

MI bit used to select either of External MPX and Internal MPX. External MPX is connected as follows.

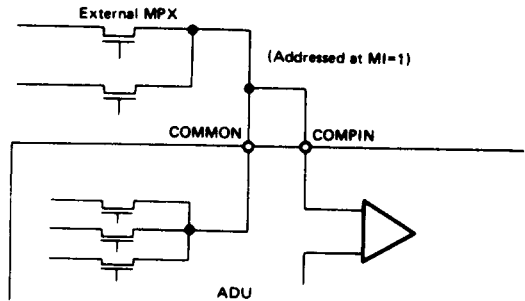

[NOTE] When external MPX is used as the way figure 20, 1 dummy AD conversion or PC at MI=1 should be performed.

Figure 21 How to use External MPX

■ DEFINITIONS OF ACCURACY

Definitions of accuracy applied to HD46508 are as follows.

- (1) Resolution ... The number of output binary digit.
- (2) Offset Error ... The difference between actual input voltage and ideal input voltage for the first transition. (when digital output code is changed from 000 ... 00 to 000 ... 01.)
- (3) Full Scale Error ... The difference between actual input voltage and ideal input voltage for the final transition. (when digital output code is changed from 111 ... 10 to 111 ... 11.)
- (4) Quantizing Error ... Error equipped in A/D converter inherently. Always $\pm 1/2$ LSB is applied.
- (5) Non-linearity Error ... The maximum deviation of the actual transfer line from an ideal straight line. This error doesn't include Quantizing Error, Offset, or Full Scale Errors.
- (6) Absolute Accuracy ... The deviation of the digital output code from an analog input voltage. Absolute accuracy includes all of (2), (3), (4), (5).

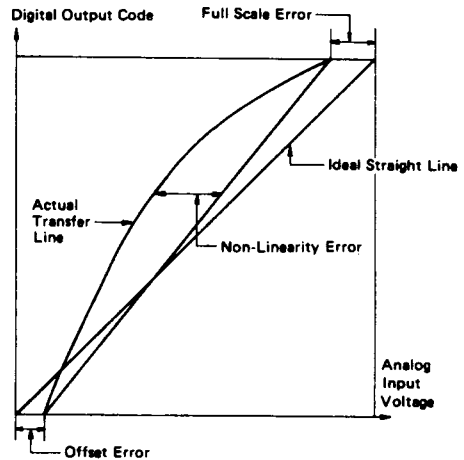
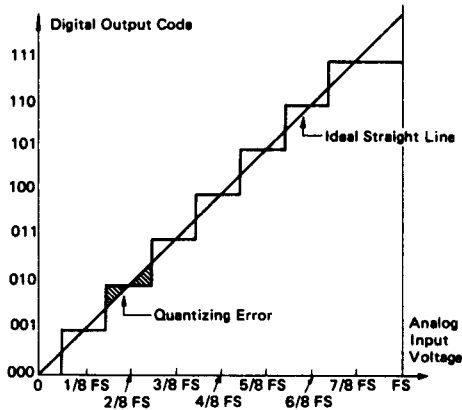

Figure 24 Definition of Accuracy