

Advance Information

Dual Intelligent High-Current Self-Protected Silicon High-Side Switch (4.0 mΩ)

The 33984 is a dual self-protected 4.0 mΩ silicon switch used to replace electromechanical relays, fuses, and discrete devices in power management applications. The 33984 is designed for harsh environments, and it includes self-recovery features. The device is suitable for loads with high inrush current, as well as motors and all types of resistive and inductive loads.

Programming, control, and diagnostics are implemented via the Serial Peripheral Interface (SPI). A dedicated parallel input is available for alternate and pulse-width modulation (PWM) control of each output. SPI-programmable fault trip thresholds allow the device to be adjusted for optimal performance in the application.

The 33984 is packaged in a power-enhanced 12 x 12 nonlead PQFN package with exposed tabs.

Features

- Dual 4.0 mΩ Max High-Side Switch with Parallel Input or SPI Control
- 6.0 V to 27 V Operating Voltage with Standby Currents < 5.0 μA
- Output Current Monitoring with Two SPI-Selectable Current Ratios
- SPI Control of Overcurrent Limit, Overcurrent Fault Blanking Time, Output-OFF Open Load Detection, Output ON/OFF Control, Watchdog Timeout, Slew Rates, and Fault Status Reporting
- SPI Status Reporting of Overcurrent, Open and Shorted Loads, Overtemperature, Undervoltage and Overvoltage Shutdown, Fail-Safe Pin Status, and Program Status
- Enhanced -16 V Reverse Polarity V_{PWR} Protection

33984

**DUAL HIGH-SIDE SWITCH
4.0 mΩ**

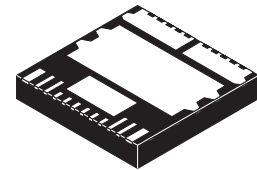

Bottom View

PNA SUFFIX
CASE 1402-02
16-TERMINAL PQFN (12 x 12)

ORDERING INFORMATION

Device	Temperature Range (T _A)	Package
MC33984PNA/R2	-40°C to 125°C	16 PQFN

33984 Simplified Application Diagram

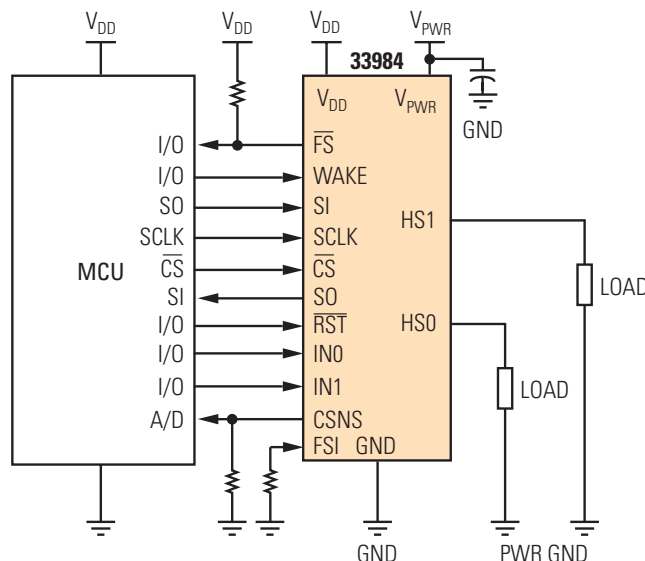

This document contains certain information on a new product. Specifications and information herein are subject to change without notice.

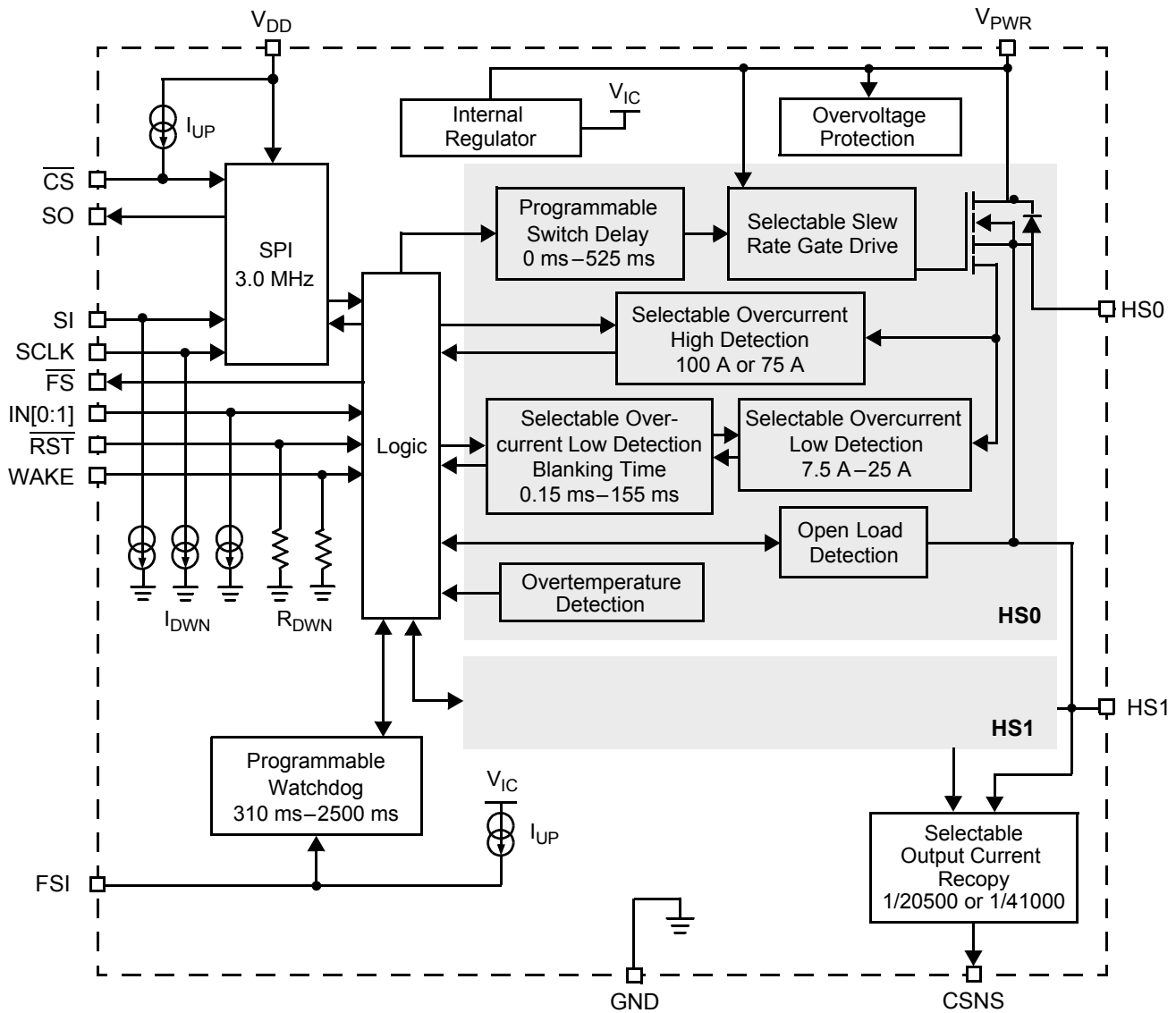
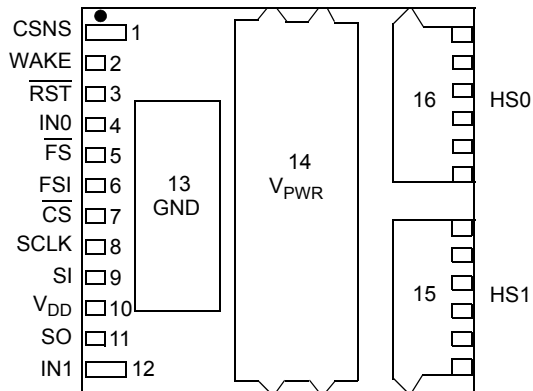

Figure 1. 33984 Simplified Internal Block Diagram

Transparent Top View of Package



TERMINAL DEFINITIONS

Functional descriptions of many of these terminals can be found in the System/Application Information section beginning on [page 15](#).

Terminal	Terminal Name	Formal Name	Definition
1	CSNS	Output Current Monitoring	This terminal is used to output a current proportional to the designated HS0-1 output. That current is fed into a ground-referenced resistor and its voltage is monitored by an MCU's A/D. The channel to be monitored is selected via the SPI. This terminal can be tri-stated through SPI.
2	WAKE	Wake	This terminal is used to input a logic [1] signal so as to enable the watchdog timer function. An internal clamp protects this terminal from high damaging voltages when the output is current limited with an external resistor. This input has a passive internal pulldown.
3	$\overline{\text{RST}}$	Reset (Active Low)	This input terminal is used to initialize the device configuration and fault registers, as well as place the device in a low current sleep mode. The terminal also starts the watchdog timer when transitioning from logic LOW to logic HIGH. This terminal should not be allowed to be logic HIGH until V_{DD} is in regulation. This terminal has a passive internal pulldown.
4	IN0	Serial Input	This input terminal is used to directly control the output HS0. This input has an active internal pulldown current source and requires CMOS logic levels. This input may be configured via SPI.
5	$\overline{\text{FS}}$	Fault Status (Active Low)	This is an open drain configured output requiring an external pullup resistor to V_{DD} for fault reporting. When a device fault condition is detected, this terminal is active LOW. Specific device diagnostic faults are reported via the SPI SO terminal.
6	FSI	Fail-Safe Input	The value of the resistance connected between this terminal and ground determines the state of the outputs after a watchdog timeout occurs. Depending on the resistance value, either all outputs are OFF, ON, or the output HS0 only is ON. When the FSI terminal is connected to GND, the watchdog circuit and fail-safe operation are disabled. This terminal incorporates an active internal pullup current source.
7	$\overline{\text{CS}}$	Chip Select (Active Low)	This input terminal is connected to a chip select output of a master microcontroller (MCU). The MCU determines which device is addressed (selected) to receive data by pulling the $\overline{\text{CS}}$ terminal of the selected device logic LOW, enabling SPI communication with the device. Other <i>unselected</i> devices on the serial link having their $\overline{\text{CS}}$ terminals pulled-up logic HIGH disregard the SPI communication data sent. This terminal incorporates an active internal pullup current source.
8	SCLK	Serial Clock	This input terminal is connected to the MCU providing the required bit shift clock for SPI communication. It transitions one time per bit transferred at an operating frequency, f_{SPI} , defined by the communication interface. The 50 percent duty cycle CMOS-level serial clock signal is idle between command transfers. The signal is used to shift data into and out of the device. This input has an active internal pulldown current source.

Freescale Semiconductor, Inc.

TERMINAL DEFINITIONS (continued)

Functional descriptions of many of these terminals can be found in the System/Application Information section beginning on [page 15](#).

Terminal	Terminal Name	Formal Name	Definition
9	SI	Serial Input	This is a command data input terminal connected to the SPI Serial Data Output of the MCU or to the SO terminal of the previous device of a daisy chain of devices. The input requires CMOS logic-level signals and incorporates an active internal pulldown current source. Device control is facilitated by the input's receiving the MSB first of a serial 8-bit control command. The MCU ensures data is available upon the falling edge of SCLK. The logic state of SI present upon the rising edge of SCLK loads that bit command into the internal command shift register.
10	V _{DD}	Digital Drain Voltage (Power)	This is an external voltage input terminal used to supply power to the SPI circuit. In the event V _{DD} is lost, an internal supply provides power to a portion of the logic, ensuring limited functionality of the device.
11	SO	Serial Output	This output terminal is connected to the SPI Serial Data Input terminal of the MCU or to the SI terminal of the next device of a daisy chain of devices. This output will remain tri-stated (high impedance OFF condition) so long as the \overline{CS} terminal of the device is logic HIGH. SO is only active when the \overline{CS} terminal of the device is asserted logic LOW. The generated SO output signals are CMOS logic levels. SO output data is available on the falling edge of SCLK and transitions immediately on the rising edge of SCLK.
12	IN1	Serial Input	This input terminal is used to directly control the output HS1. This input has an active internal pulldown current source and requires CMOS logic levels. This input may be configured via SPI.
13	GND	Ground	This terminal is the ground for the logic and analog circuitry of the device.
14	V _{PWR}	Positive Power Supply	This terminal connects to the positive power supply and is the source input of operational power for the device. The V _{PWR} terminal is a backside surface mount tab of the package.
15	HS1	High-Side Output 1	Protected 4.0 mΩ high-side power output to the load.
16	HS0	High-Side Output 0	Protected 4.0 mΩ high-side power output to the load.

Freescale Semiconductor, Inc.

MAXIMUM RATINGS

All voltages are with respect to ground unless otherwise noted.

Rating	Symbol	Value	Unit
ELECTRICAL RATINGS			
Operating Voltage Range Steady-State	V_{PWR}	-16 to 41	V
V_{DD} Supply Voltage	V_{DD}	0 to 5.5	V
Input/Output Voltage (Note 1)	$V_{IN[0:1]}, \overline{RST}, FSI$ $CSNS, SI, SCLK,$ $\overline{CS}, \overline{FS}$	-0.3 to 7.0	V
SO Output Voltage (Note 1)	V_{SO}	-0.3 to $V_{DD} + 0.3$	V
WAKE Input Clamp Current	$I_{CL(WAKE)}$	2.5	mA
CSNS Input Clamp Current	$I_{CL(CSNS)}$	10	mA
Output Current (Note 2)	$I_{HS[0:1]}$	30	A
Output Clamp Energy (Note 3)	$E_{CL[0:1]}$	0.75	J
ESD Voltage			V
Human Body Model (Note 4)	V_{ESD1}	±2000	
Machine Model (Note 5)	V_{ESD2}	±200	

THERMAL RATINGS

Operating Temperature			°C
Ambient	T_A	-40 to 125	
Junction	T_J	-40 to 150	
Storage Temperature	T_{STG}	-55 to 150	°C
Thermal Resistance (Note 6)			°C/W
Junction to Case	$R_{\theta JC}$	<1.0	
Junction to Ambient	$R_{\theta JA}$	20	
Peak Terminal Reflow Temperature During Solder Mounting (Note 7)	T_{SOLDER}	230	°C

Notes

- Exceeding voltage limits on \overline{RST} , IN[0:1], or FSI terminals may cause a malfunction or permanent damage to the device.
- Continuous high-side output current rating so long as maximum junction temperature is not exceeded. Calculation of maximum output current using package thermal resistance is required.
- Active clamp energy using single-pulse method ($L = 16$ mH, $R_L = 0$, $V_{PWR} = 12$ V, $T_J = 150^\circ\text{C}$).
- ESD1 testing is performed in accordance with the Human Body Model ($C_{ZAP} = 100$ pF, $R_{ZAP} = 1500 \Omega$).
- ESD2 testing is performed in accordance with the Machine Model ($C_{ZAP} = 200$ pF, $R_{ZAP} = 0 \Omega$).
- Device mounted on a 2s2p test board according to JEDEC JESD51-2.
- Terminal soldering temperature limit is for 10 seconds maximum duration. Not designed for immersion soldering. Exceeding these limits may cause malfunction or permanent damage to the device.

Freescale Semiconductor, Inc.

STATIC ELECTRICAL CHARACTERISTICS

Characteristics noted under conditions $4.5\text{ V} \leq V_{DD} \leq 5.5\text{ V}$, $6.0\text{ V} \leq V_{PWR} \leq 27\text{ V}$, $-40^\circ\text{C} \leq T_J \leq 150^\circ\text{C}$ unless otherwise noted. Typical values noted reflect the approximate parameter mean at $T_A = 25^\circ\text{C}$ under nominal conditions unless otherwise noted.

Characteristic	Symbol	Min	Typ	Max	Unit
POWER INPUT					
Battery Supply Voltage Range Full Operational	V_{PWR}	6.0	–	27	V
V_{PWR} Operating Supply Current Output ON, I_{HS0} and $I_{HS1} = 0\text{ A}$	$I_{PWR(ON)}$	–	–	20	mA
V_{PWR} Supply Current Output OFF, Open Load Detection Disabled, WAKE > 0.7 V_{DD} , $\overline{RST} = V_{LOGIC\ HIGH}$	$I_{PWR(SBY)}$	–	–	5.0	mA
Sleep State Supply Current ($V_{PWR} < 14\text{ V}$, $\overline{RST} < 0.5\text{ V}$, WAKE < 0.5 V) $T_J = 25^\circ\text{C}$ $T_J = 85^\circ\text{C}$	$I_{PWR(SLEEP)}$	– –	– –	10 50	μA
V_{DD} Supply Voltage	$V_{DD(ON)}$	4.5	5.0	5.5	V
V_{DD} Supply Current No SPI Communication 3.0 MHz SPI Communication	$I_{DD(ON)}$	– –	– –	1.0 5.0	mA
V_{DD} Sleep State Current	$I_{DD(SLEEP)}$	–	–	5.0	μA
Overvoltage Shutdown Threshold	$V_{PWR(OV)}$	28	32	36	V
Overvoltage Shutdown Hysteresis	$V_{PWR(OVHYS)}$	0.2	0.8	1.5	V
Undervoltage Output Shutdown Threshold (Note 8)	$V_{PWR(UV)}$	5.0	5.5	6.0	V
Undervoltage Hysteresis (Note 9)	$V_{PWR(UVHYS)}$	–	0.25	–	V
Undervoltage Power-ON Reset	$V_{PWR(UVPOR)}$	–	–	5.0	V

Notes

- Output will automatically recover to instructed state when V_{PWR} voltage is restored to normal so long as the V_{PWR} degradation level did not go below the undervoltage power-ON reset threshold. This applies to all internal device logic that is supplied by V_{PWR} and assumes that the external V_{DD} supply is within specification.
- This applies when the undervoltage fault is not latched ($IN[0:1] = 0$).

Freescale Semiconductor, Inc.

STATIC ELECTRICAL CHARACTERISTICS (continued)

Characteristics noted under conditions $4.5\text{ V} \leq V_{DD} \leq 5.5\text{ V}$, $6.0\text{ V} \leq V_{PWR} \leq 27\text{ V}$, $-40^\circ\text{C} \leq T_J \leq 150^\circ\text{C}$ unless otherwise noted. Typical values noted reflect the approximate parameter mean at $T_A = 25^\circ\text{C}$ under nominal conditions unless otherwise noted.

Characteristic	Symbol	Min	Typ	Max	Unit
POWER OUTPUT					
Output Drain-to-Source ON Resistance ($I_{HS[0:1]} = 30\text{ A}$, $T_J = 25^\circ\text{C}$) $V_{PWR} = 6.0\text{ V}$ $V_{PWR} = 10\text{ V}$ $V_{PWR} = 13\text{ V}$	$R_{DS(ON)}$	–	–	6.0 4.0 4.0	$\text{m}\Omega$
Output Drain-to-Source ON Resistance ($I_{HS[0:1]} = 30\text{ A}$, $T_J = 150^\circ\text{C}$) $V_{PWR} = 6.0\text{ V}$ $V_{PWR} = 10\text{ V}$ $V_{PWR} = 13\text{ V}$	$R_{DS(ON)}$	–	–	10.2 6.8 6.8	$\text{m}\Omega$
Output Source-to-Drain ON Resistance $I_{HS[0:1]} = 15\text{ A}$, $T_J = 25^\circ\text{C}$ (Note 10) $V_{PWR} = -12\text{ V}$	$R_{DS(ON)}$	–	–	8.0	$\text{m}\Omega$
Output Overcurrent High Detection Levels ($9.0\text{ V} \leq V_{PWR} \leq 16\text{ V}$) SOCH = 0 SOCH = 1	I_{OCH0} I_{OCH1}	80 60	100 75	120 90	A
Overcurrent Low Detection Levels (SOCL[2:0]) 000 001 010 011 100 101 110 111	I_{OCL0} I_{OCL1} I_{OCL2} I_{OCL3} I_{OCL4} I_{OCL5} I_{OCL6} I_{OCL7}	21 18 16 14 12 10 8.0 6.0	25 22.5 20 17.5 15 12.5 10 7.5	29 27 24 21 17 15 12 9.0	A
Current Sense Ratio ($9.0\text{ V} \leq V_{PWR} \leq 16\text{ V}$, $CSNS \leq 4.5\text{ V}$) DICR D2 = 0 DICR D2 = 1	C_{SR0} C_{SR1}	– –	1/20500 1/41000	– –	–
Current Sense Ratio (C_{SR0}) Accuracy Output Current 5.0 A 10 A 12.5 A 15 A 20 A 25 A	C_{SR0_ACC}	–20 –14 –13 –12 –13 –13	– – – – – –	20 14 13 12 13 13	%

Notes

10. Source-Drain ON Resistance (Reverse Drain-to-Source ON Resistance) with negative polarity V_{PWR} .

Freescale Semiconductor, Inc.

STATIC ELECTRICAL CHARACTERISTICS (continued)

Characteristics noted under conditions $4.5\text{ V} \leq V_{DD} \leq 5.5\text{ V}$, $6.0\text{ V} \leq V_{PWR} \leq 27\text{ V}$, $-40^\circ\text{C} \leq T_J \leq 150^\circ\text{C}$ unless otherwise noted. Typical values noted reflect the approximate parameter mean at $T_A = 25^\circ\text{C}$ under nominal conditions unless otherwise noted.

Characteristic	Symbol	Min	Typ	Max	Unit
POWER OUTPUT (continued)					
Current Sense Ratio (C_{SR1}) Accuracy	C_{SR1_ACC}				%
Output Current					
5.0 A		-25	–	25	
10 A		-19	–	19	
12.5 A		-18	–	18	
15 A		-17	–	17	
20 A		-18	–	18	
25 A		-18	–	18	
Current Sense Clamp Voltage CSNS Open; $I_{HS[0:1]} = 29\text{ A}$	$V_{CL(CSNS)}$	4.5	6.0	7.0	V
Open Load Detection Current (Note 11)	I_{OLDC}	30	–	100	μA
Output Fault Detection Threshold Output Programmed OFF	$V_{OLD(THRES)}$	2.0	3.0	4.0	V
Output Negative Clamp Voltage $0.5\text{ A} \leq I_{HS[0:1]} \leq 2.0\text{ A}$, Output OFF	V_{CL}	-20	–	–	V
Overtemperature Shutdown (Note 12)	T_{SD}	160	175	190	$^\circ\text{C}$
Overtemperature Shutdown Hysteresis (Note 12)	$T_{SD(HYS)}$	5.0	–	20	$^\circ\text{C}$

Notes

- Output OFF Open Load Detection Current is the current required to flow through the load for the purpose of detecting the existence of an open load condition when the specific output is commanded OFF.
- Guaranteed by process monitoring. Not production tested.

Freescale Semiconductor, Inc.

STATIC ELECTRICAL CHARACTERISTICS (continued)

Characteristics noted under conditions $4.5\text{ V} \leq V_{DD} \leq 5.5\text{ V}$, $6.0\text{ V} \leq V_{PWR} \leq 27\text{ V}$, $-40^\circ\text{C} \leq T_J \leq 150^\circ\text{C}$ unless otherwise noted. Typical values noted reflect the approximate parameter mean at $T_A = 25^\circ\text{C}$ under nominal conditions unless otherwise noted.

Characteristic	Symbol	Min	Typ	Max	Unit
CONTROL INTERFACE					
Input Logic High Voltage (Note 13)	V_{IH}	$0.7V_{DD}$	–	–	V
Input Logic Low Voltage (Note 13)	V_{IL}	–	–	$0.2V_{DD}$	V
Input Logic Voltage Hysteresis (Note 14)	$V_{IN[0:1](HYS)}$	100	350	750	mV
Input Logic Pulldown Current (SCLK, IN, SI)	I_{DWN}	5.0	–	20	μA
$\overline{\text{RST}}$ Input Voltage Range	$V_{\overline{\text{RST}}}$	4.5	5.0	5.5	V
SO, $\overline{\text{FS}}$ Tri-State Capacitance (Note 15)	C_{SO}	–	–	20	pF
Input Logic Pulldown Resistor ($\overline{\text{RST}}$) and WAKE	R_{DWN}	100	200	400	$\text{k}\Omega$
Input Capacitance (Note 15)	C_{IN}	–	4.0	12	pF
WAKE Input Clamp Voltage (Note 16) $I_{CL(WAKE)} < 2.5\text{ mA}$	$V_{CL(WAKE)}$	7.0	–	14	V
WAKE Input Forward Voltage $I_{CL(WAKE)} = -2.5\text{ mA}$	$V_{F(WAKE)}$	-2.0	–	-0.3	V
SO High-State Output Voltage $I_{OH} = 1.0\text{ mA}$	V_{SOH}	$0.8V_{DD}$	–	–	V
$\overline{\text{FS}}$, SO Low-State Output Voltage $I_{OL} = -1.6\text{ mA}$	V_{SOL}	–	0.2	0.4	V
SO Tri-State Leakage Current $\overline{\text{CS}} > 0.7V_{DD}$	$I_{SO(LEAK)}$	-5.0	0	5.0	μA
Input Logic Pullup Current (Note 17) $\overline{\text{CS}}, V_{IN[0:1]} > 0.7V_{DD}$	I_{UP}	5.0	–	20	μA
FSI Input Terminal External Pulldown Resistance	RFS				$\text{k}\Omega$
FSI Disabled, HS[0:1] Indeterminate	RFSdis	–	0	1.0	
FSI Enabled, HS[0:1] OFF	RFSoff	6.0	6.5	7.0	
FSI Enabled, HS0 ON, HS1 OFF	RFSonoff	15	17	19	
FSI Enabled, HS[0:1] ON	RFSon	40	Infinite	–	

Notes

- Upper and lower logic threshold voltage range applies to SI, $\overline{\text{CS}}$, SCLK, $\overline{\text{RST}}$, IN[0:1], and WAKE input signals. The WAKE and $\overline{\text{RST}}$ signals may be supplied by a derived voltage reference to V_{PWR} .
- Parameter is guaranteed by processing monitoring but is not production tested.
- Input capacitance of SI, $\overline{\text{CS}}$, SCLK, $\overline{\text{RST}}$, and WAKE. This parameter is guaranteed by process monitoring but is not production tested.
- The current must be limited by a series resistance when using voltages $> 7.0\text{ V}$.
- Pullup current is with $\overline{\text{CS}}$ OPEN. $\overline{\text{CS}}$ has an active internal pullup to V_{DD} .

Freescale Semiconductor, Inc.

DYNAMIC ELECTRICAL CHARACTERISTICS

Characteristics noted under conditions $4.5\text{ V} \leq V_{DD} \leq 5.5\text{ V}$, $6.0\text{ V} \leq V_{PWR} \leq 27\text{ V}$, $-40^\circ\text{C} \leq T_J \leq 150^\circ\text{C}$ unless otherwise noted. Typical values noted reflect the approximate parameter mean at $T_A = 25^\circ\text{C}$ under nominal conditions unless otherwise noted.

Characteristic	Symbol	Min	Typ	Max	Unit
POWER OUTPUT TIMING					
Output Rising Slow Slew Rate A (DICR D3 = 0) (Note 18) $9.0\text{ V} < V_{PWR} < 16\text{ V}$	SR _{RA_SLOW}	0.2	0.6	1.2	V/ μ s
Output Rising Slow Slew Rate B (DICR D3 = 0) (Note 19) $9.0\text{ V} < V_{PWR} < 16\text{ V}$	SR _{RB_SLOW}	0.03	0.1	0.3	V/ μ s
Output Rising Fast Slew Rate A (DICR D3 = 1) (Note 18) $9.0\text{ V} < V_{PWR} < 16\text{ V}$	SR _{RA_FAST}	0.4	1.0	4.0	V/ μ s
Output Rising Fast Slew Rate B (DICR D3 = 1) (Note 19) $9.0\text{ V} < V_{PWR} < 16\text{ V}$	SR _{RB_FAST}	0.03	0.1	1.2	V/ μ s
Output Falling Slow Slew Rate A (DICR D3 = 0) (Note 18) $9.0\text{ V} < V_{PWR} < 16\text{ V}$	SR _{FA_SLOW}	0.2	0.6	1.2	V/ μ s
Output Falling Slow Slew Rate B (DICR D3 = 0) (Note 19) $9.0\text{ V} < V_{PWR} < 16\text{ V}$	SR _{FB_SLOW}	0.03	0.1	0.3	V/ μ s
Output Falling Fast Slew Rate A (DICR D3 = 1) (Note 18) $9.0\text{ V} < V_{PWR} < 16\text{ V}$	SR _{FA_FAST}	0.8	2.0	4.0	V/ μ s
Output Falling Fast Slew Rate B (DICR D3 = 1) (Note 19) $9.0\text{ V} < V_{PWR} < 16\text{ V}$	SR _{FB_FAST}	0.1	0.35	1.2	V/ μ s
Output Turn-ON Delay Time in Fast/Slow Slew Rate (Note 20) DICR = 0, DICR = 1	t _{DLY(ON)}	1.0	15	100	μ s
Output Turn-OFF Delay Time in Slow Slew Rate Mode (Note 21) DICR = 0	t _{DLY_SLOW(OFF)}	20	230	500	μ s
Output Turn-OFF Delay Time in Fast Slew Rate Mode (Note 21) DICR = 1	t _{DLY_FAST(OFF)}	10	60	200	μ s
Direct Input Switching Frequency (DICR D3 = 0)	f _{PWM}	–	300	–	Hz

Notes

- Rise and Fall Slew Rates A measured across a $5.0\ \Omega$ resistive load at high-side output = 0.5 V to $V_{PWR}-3.5\text{ V}$. These parameters are guaranteed by process monitoring.
- Rise and Fall Slew Rates B measured across a $5.0\ \Omega$ resistive load at high-side output = 0.5 V to $V_{PWR}-3.5\text{ V}$. These parameters are guaranteed by process monitoring.
- Turn-ON delay time measured from rising edge of IN[0:1] signal that would turn the output ON to $V_{HS[0:1]} = 0.5\text{ V}$ with $R_L = 5.0\ \Omega$ resistive load.
- Turn-OFF delay time measured from falling edge that would turn the output OFF to $V_{HS[0:1]} = V_{PWR}-0.5\text{ V}$ with $R_L = 5.0\ \Omega$ resistive load.

Freescale Semiconductor, Inc.

DYNAMIC ELECTRICAL CHARACTERISTICS (continued)

Characteristics noted under conditions $4.5\text{ V} \leq V_{DD} \leq 5.5\text{ V}$, $6.0\text{ V} \leq V_{PWR} \leq 27\text{ V}$, $-40^\circ\text{C} \leq T_J \leq 150^\circ\text{C}$ unless otherwise noted. Typical values noted reflect the approximate parameter mean at $T_A = 25^\circ\text{C}$ under nominal conditions unless otherwise noted.

Characteristic	Symbol	Min	Typ	Max	Unit
POWER OUTPUT TIMING (continued)					
Overcurrent Detection Blanking Time (OCLT[1:0])					ms
00	t_{OCL0}	108	155	202	
01	t_{OCL1}	7.0	10	13	
10	t_{OCL2}	0.8	1.2	1.6	
11	t_{OCL3}	0.08	0.15	0.25	
Overcurrent High Detection Blanking Time	t_{OCH}	1.0	10	20	μs
$\overline{\text{CS}}$ to CSNS Valid Time (Note 22)	t_{CNSVAL}	–	–	10	μs
HS0 Switching Delay Time (OSD[2:0])					ms
000	t_{OSD0}	–	0	–	
001	t_{OSD1}	55	75	95	
010	t_{OSD2}	110	150	190	
011	t_{OSD3}	165	225	285	
100	t_{OSD4}	220	300	380	
101	t_{OSD5}	275	375	475	
110	t_{OSD6}	330	450	570	
111	t_{OSD7}	385	525	665	
HS1 Switching Delay Time (OSD[2:0])					ms
000	t_{OSD0}	–	0	–	
001	t_{OSD1}	–	0	–	
010	t_{OSD2}	110	150	190	
011	t_{OSD3}	110	150	190	
100	t_{OSD4}	220	300	380	
101	t_{OSD5}	220	300	380	
110	t_{OSD6}	330	450	570	
111	t_{OSD7}	330	450	570	
Watchdog Timeout (WD[1:0]) (Note 23)					ms
00	t_{WDTO0}	434	620	806	
01	t_{WDTO1}	207	310	403	
10	t_{WDTO2}	1750	2500	3250	
11	t_{WDTO3}	875	1250	1625	

Notes

- Time necessary for the CSNS to be within $\pm 5\%$ of the targeted value.
- Watchdog timeout delay measured from the rising edge of WAKE to $\overline{\text{RST}}$ from a sleep state condition to output turn-ON with the output driven OFF and FSI floating. The values shown are for WDR setting of [00]. The accuracy of t_{WDTO} is consistent for all configured watchdog timeouts.

Freescale Semiconductor, Inc.

DYNAMIC ELECTRICAL CHARACTERISTICS (continued)

Characteristics noted under conditions $4.5\text{ V} \leq V_{DD} \leq 5.5\text{ V}$, $6.0\text{ V} \leq V_{PWR} \leq 27\text{ V}$, $-40^\circ\text{C} \leq T_J \leq 150^\circ\text{C}$ unless otherwise noted. Typical values noted reflect the approximate parameter mean at $T_A = 25^\circ\text{C}$ under nominal conditions unless otherwise noted.

Characteristic	Symbol	Min	Typ	Max	Unit
SPI INTERFACE CHARACTERISTICS					
Recommended Frequency of SPI Operation	f_{SPI}	–	–	3.0	MHz
Required Low State Duration for $\overline{\text{RST}}$ (Note 24)	t_{WRST}	–	50	350	ns
Rising Edge of $\overline{\text{CS}}$ to Falling Edge of $\overline{\text{CS}}$ (Required Setup Time) (Note 25)	$t_{\overline{\text{CS}}}$	–	–	300	ns
Rising Edge of $\overline{\text{RST}}$ to Falling Edge of $\overline{\text{CS}}$ (Required Setup Time) (Note 25)	t_{ENBL}	–	–	5.0	μs
Falling Edge of $\overline{\text{CS}}$ to Rising Edge of SCLK (Required Setup Time) (Note 25)	t_{LEAD}	–	50	167	ns
Required High State Duration of SCLK (Required Setup Time) (Note 25)	t_{WSCLKh}	–	–	167	ns
Required Low State Duration of SCLK (Required Setup Time) (Note 25)	t_{WSCLKl}	–	–	167	ns
Falling Edge of SCLK to Rising Edge of $\overline{\text{CS}}$ (Required Setup Time) (Note 25)	t_{LAG}	–	50	167	ns
SI to Falling Edge of SCLK (Required Setup Time) (Note 26)	$t_{\text{SI(SU)}}$	–	25	83	ns
Falling Edge of SCLK to SI (Required Setup Time) (Note 26)	$t_{\text{SI(HOLD)}}$	–	25	83	ns
SO Rise Time $C_L = 200\text{ pF}$	t_{RSO}	–	25	50	ns
SO Fall Time $C_L = 200\text{ pF}$	t_{FSO}	–	25	50	ns
SI, $\overline{\text{CS}}$, SCLK, Incoming Signal Rise Time (Note 26)	t_{RSI}	–	–	50	ns
SI, $\overline{\text{CS}}$, SCLK, Incoming Signal Fall Time (Note 26)	t_{RSI}	–	–	50	ns
Time from Falling Edge of $\overline{\text{CS}}$ to SO Low Impedance (Note 27)	$t_{\text{SO(EN)}}$	–	–	145	ns
Time from Rising Edge of $\overline{\text{CS}}$ to SO High Impedance (Note 28)	$t_{\text{SO(DIS)}}$	–	65	145	ns
Time from Rising Edge of SCLK to SO Data Valid (Note 29) $0.2 V_{DD} \leq \text{SO} \leq 0.8 V_{DD}$, $C_L = 200\text{ pF}$	t_{VALID}	–	65	105	ns

Notes

24. $\overline{\text{RST}}$ low duration measured with outputs enabled and going to OFF or disabled condition.
25. Maximum setup time required for the 33984 is the minimum guaranteed time needed from the microcontroller.
26. Rise and Fall time of incoming SI, $\overline{\text{CS}}$, and SCLK signals suggested for design consideration to prevent the occurrence of double pulsing.
27. Time required for output status data to be available for use at SO. 1.0 k Ω on pullup on $\overline{\text{CS}}$.
28. Time required for output status data to be terminated at SO. 1.0 k Ω on pullup on $\overline{\text{CS}}$.
29. Time required to obtain valid data out from SO following the rise of SCLK.

Timing Diagrams

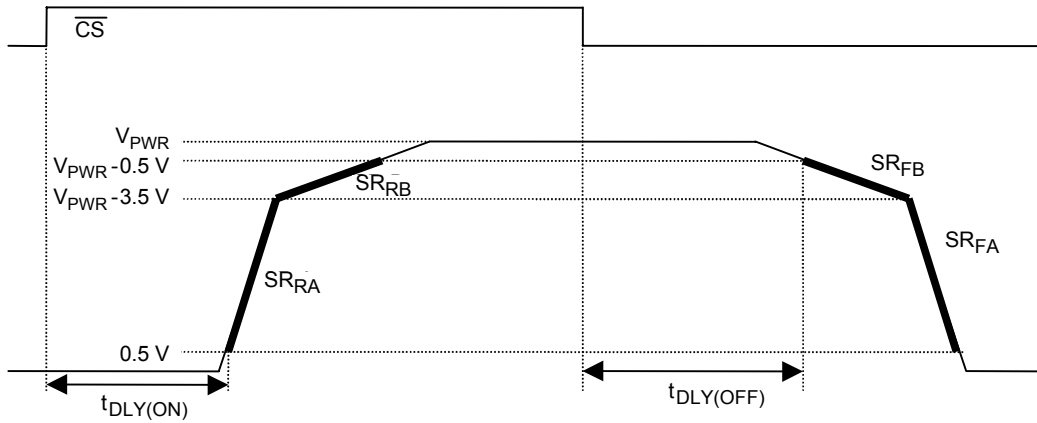

Figure 2. Output Slew Rate and Time Delays

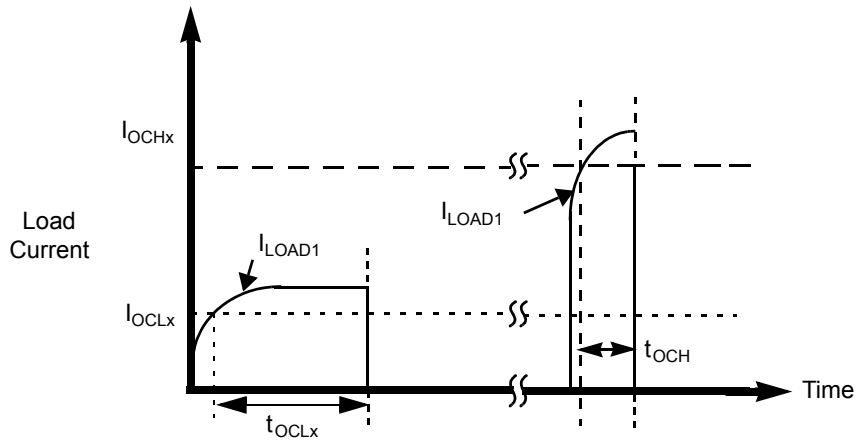

Figure 3. Overcurrent Shutdown

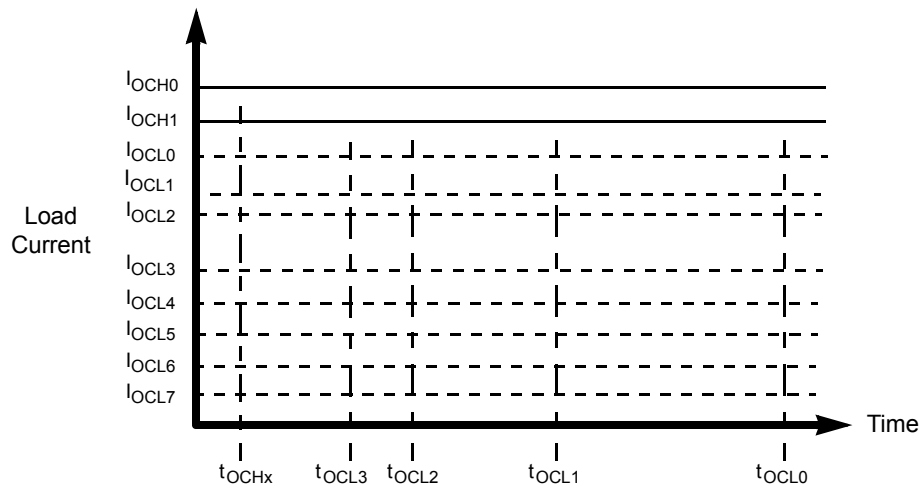

Figure 4. Overcurrent Low and High Detection

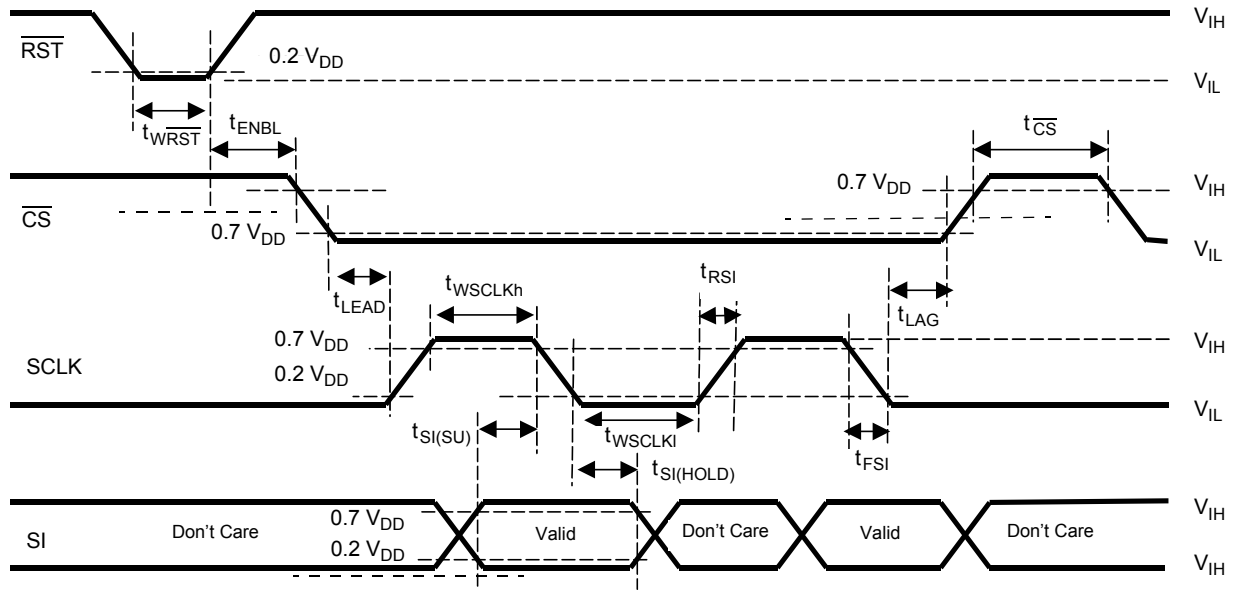

Figure 5. Input Timing Switching Characteristics

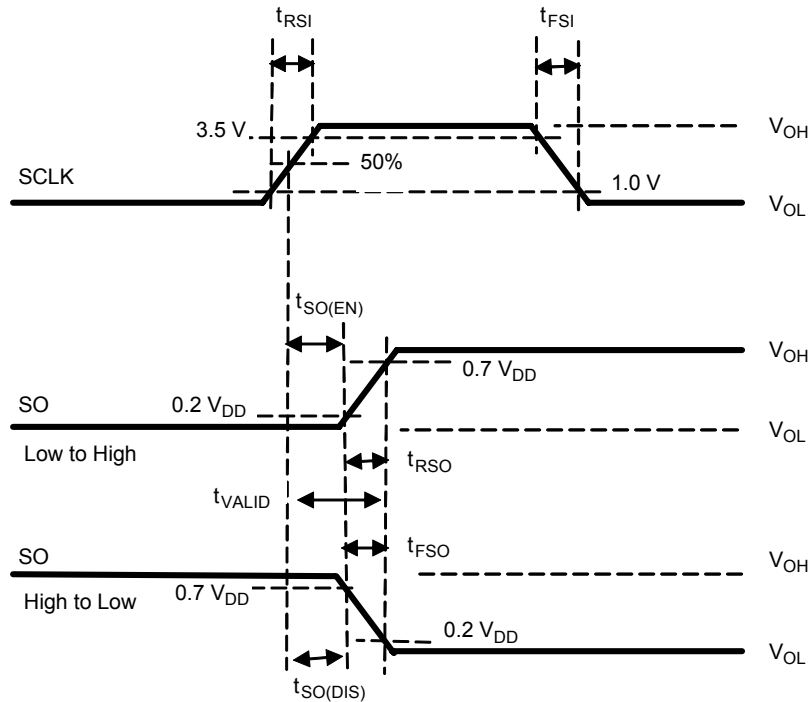

Figure 6. SCLK Waveform and Valid SO Data Delay Time

SYSTEM/APPLICATION INFORMATION

INTRODUCTION

The 33984 is a dual self-protected 4.0 mΩ silicon switch used to replace electromechanical relays, fuses, and discrete devices in power management applications. The 33984 is designed for harsh environments, and it includes self-recovery features. The device is suitable for loads with high inrush current, as well as motors and all types of resistive and inductive loads.

Programming, control, and diagnostics are implemented via the Serial Peripheral Interface (SPI). A dedicated parallel input is available for alternate and Pulse Width Modulation (PWM) control of each output. SPI-programmable fault trip thresholds allow the device to be adjusted for optimal performance in the application.

The 33984 is packaged in a power-enhanced 12 x 12 nonleaded PQFN package with exposed tabs.

FUNCTIONAL DESCRIPTION

SPI Protocol Description

The SPI interface has a full duplex, three-wire synchronous data transfer with four I/O lines associated with it: Serial Clock (SCLK), Serial Input (SI), Serial Output (SO), and Chip Select (\overline{CS}).

The SI/SO terminals of the 33984 follow a first-in first-out (D7/D0) protocol with both input and output words transferring the most significant bit (MSB) first. All inputs are compatible with 5.0 V CMOS logic levels.

The SPI lines perform the following functions:

Serial Clock (SCLK)

Serial clocks (SCLK) the internal shift registers of the 33984 device. The serial input (SI) terminal accepts data into the input shift register on the falling edge of the SCLK signal while the serial output (SO) terminal shifts data information out of the SO line driver on the rising edge of the SCLK signal. It is important that the SCLK terminal be in a logic low state whenever \overline{CS} makes any transition. For this reason, it is recommended that the SCLK terminal be in a logic [0] state whenever the device is not accessed (\overline{CS} logic [1] state). SCLK has an active internal pulldown, I_{DWN} . When \overline{CS} is logic [1], signals at the SCLK and SI terminals are ignored and SO is tri-stated (high impedance). (See [Figure 7](#) and [Figure 8](#) on page 16.)

Serial Input (SI)

This is a serial interface (SI) command data input terminal. SI instruction is read on the falling edge of SCLK. An 8-bit stream of serial data is required on the SI terminal, starting with D7 to

D0. The internal registers of the 33984 are configured and controlled using a 4-bit addressing scheme, as shown in [Table 1](#), page 16. Register addressing and configuration are described in [Table 2](#), page 17. The SI input has an active internal pulldown, I_{DWN} .

Serial Output (SO)

The SO data terminal is a tri-stateable output from the shift register. The SO terminal remains in a high impedance state until the \overline{CS} terminal is put into a logic [0] state. The SO data is capable of reporting the status of the output, the device configuration, and the state of the key inputs. The SO terminal changes states on the rising edge of SCLK and reads out on the falling edge of SCLK. Fault and Input Status descriptions are provided in [Table 11](#), page 21.

Chip Select (\overline{CS})

The \overline{CS} terminal enables communication with the master microcontroller (MCU). When this terminal is in a logic [0] state, the device is capable of transferring information to, and receiving information from, the MCU. The 33984 device latches in data from the Input shift registers to the addressed registers on the rising edge of \overline{CS} . The device transfers status information from the power output to the shift register on the falling edge of \overline{CS} . The SO output driver is enabled when \overline{CS} is logic [0]. \overline{CS} should transition from a logic [1] to a logic [0] state only when SCLK is a logic [0]. \overline{CS} has an active internal pullup, I_{UP} .

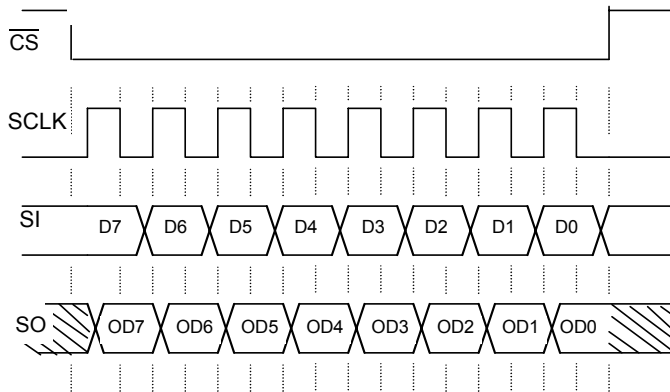

- Notes
1. $\overline{\text{RST}}$ is a logic [1] state during the above operation.
 2. D7:D0 relate to the most recent ordered entry of data into the device.
 3. OD7:OD0 relate to the first 8 bits of ordered fault and status data out of the device.

Figure 7. Single 8-Bit Word SPI Communication

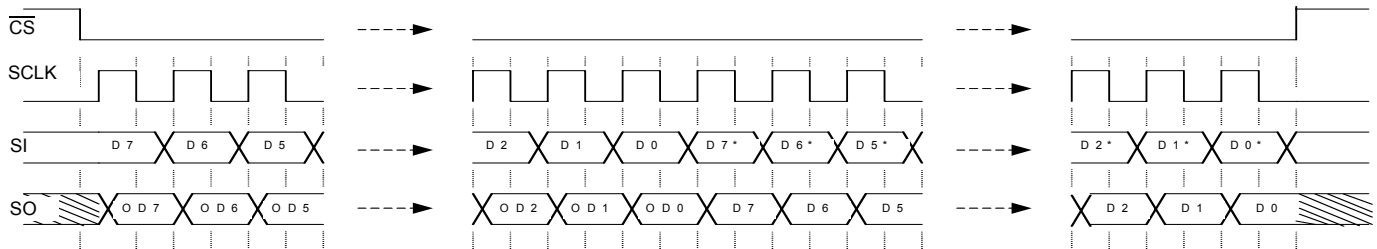

- Notes
1. $\overline{\text{RST}}$ is a logic [1] state during the above operation.
 2. D7:D0 relate to the most recent ordered entry of data into the device.
 3. D7*:D0* relate to the previous 8 bits (last command word) of data that was previously shifted into the device.
 4. OD7:OD0 relate to the first 8 bits of ordered fault and status data out of the device.

Figure 8. Multiple 8-Bit Word SPI Communication

Serial Input Communication

SPI communication is accomplished using 8-bit messages. A message is transmitted by the MCU starting with the MSB, D7, and ending with the LSB, D0 (Table 1). Each incoming command message on the SI terminal can be interpreted using the following bit assignments: the MSB (D7) is the watchdog bit and in some cases a register address bit common to both outputs or specific to an output; the next three bits, D6:D4, are used to select the command register; and the remaining four bits, D3:D0, are used to configure and control the outputs and their protection features.

Multiple messages can be transmitted in succession to accommodate those applications where daisy chaining is desirable, or to confirm transmitted data, as long as the messages are all multiples of eight bits. Any attempt made to latch in a message that is not eight bits will be ignored.

The 33984 has defined registers, which are used to configure the device and to control the state of the output. Table 2 page 17, summarizes the SI registers. The registers are addressed via D6:D4 of the incoming SPI word (Table 1).

Table 1. SI Message Bit Assignment

Bit Sig	SI Msg Bit	Message Bit Description
MSB	D7	Register address bit for output selection. Also used for Watchdog: toggled to satisfy watchdog requirements.
	D6:D4	Register address bits.
	D3:D1	Used to configure the inputs, outputs, and the device protection features and SO status content.
LSB	D0	Used to configure the inputs, outputs, and the device protection features and SO status content.

Table 2. Serial Input Address and Configuration Bit Map

SI Register	Serial Input Data							
	D7	D6	D5	D4	D3	D2	D1	D0
STATR	SO A3	0	0	0	0	SOA2	SOA1	SOA0
OCR	x	0	0	1	CSNS1 EN	IN1_SPI	CSNS0 EN	IN0_SPI
SOCHLR	s	0	1	0	SOCHs	SOCL2s	SOCL1s	SOCL0s
CDTOLR	s	0	1	1	OL DIS s	CD DIS s	OCLT1s	OCLT0s
DICR	s	1	0	0	FAST SR s	CSNS high s	IN DIS s	A/Os
OSDR	0	1	0	1	0	OSD2	OSD1	OSD0
WDR	1	1	0	1	0	0	WD1	WD0
NAR	0	1	1	0	0	0	0	0
UOVR	1	1	1	0	0	0	UV_dis	OV_dis
TEST	x	1	1	1	Motorola Internal Use (Test)			

x = Don't care.

s = Selection of output: logic [0] = HS0, logic [1] = HS1.

Device Register Addressing

The following section describes the possible register addresses and their impact on device operation.

Address x000—Status Register (STATR)

The STATR register is used to read the device status and the various configuration register contents without disrupting the device operation or the register contents. The register bits D2:D0, determine the content of the first eight bits of SO data. When register content is specific to one of the two outputs, bit D7 is used to select the desired output. In addition to the device status, this feature provides the ability to read the content of the OCR, SOCHLR, CDTOLR, DICR, OSDR, WDR, NAR, and UOVR registers. (Refer to the section entitled [Serial Output Communication \(Device Status Return Data\)](#) beginning on page 19.)

Address x001—Output Control Register (OCR)

The OCR register allows the MCU to control the outputs through the SPI. Incoming message bit D0 reflects the desired states of the high-side output HS0 (IN0_SPI): a logic [1] enables the output switch and a logic [0] turns it OFF. A logic [1] on message bit D1 enables the Current Sense (CSNS) terminal. Similarly, incoming message bit D2 reflects the desired states of the high-side output HS1 (IN1_SPI): logic [1] enables the output switch and a logic [0] turns it OFF. A logic [1] on message bit D3 enables the CSNS terminal. In the event that the current sense is enabled for both outputs, the current will be summed. Bit D7 is used to feed the watchdog if enabled.

Address x010—Select Overcurrent High and Low Register (SOCHLR)

The SOCHLR register allows the MCU to configure the output overcurrent low and high detection levels, respectively. Each output is independently selected for configuration based on the state of the D7 bit; a write to this register when D7 is logic [0] will configure the current detection levels for the HS0. Similarly, if D7 is logic [1] when this register is written, HS1 is configured. Each output can be configured to different levels. In addition to protecting the device, this slow blow fuse emulation feature can be used to optimize the load requirements matching system characteristics. Bits D2:D0 set the overcurrent low detection level to one of eight possible levels, as shown in [Table 3](#). Bit D3 sets the overcurrent high detection level to one of two levels, which is described in [Table 4](#).

Table 3. Overcurrent Low Detection Levels

SOCL2 (D2)	SOCL1 (D1)	SOCL0 (D0)	Overcurrent Low Detection (Amperes)
0	0	0	25
0	0	1	22.5
0	1	0	20
0	1	1	17.5
1	0	0	15
1	0	1	12.5
1	1	0	10
1	1	1	7.5

Table 4. Overcurrent High Detection Levels

SOCH (D3)	Overcurrent High Detection (Amperes)
0	100
1	75

Address x011—Current Detection Time and Open Load Register (CDTOLR)

The CDTOLR register is used by the MCU to determine the amount of time the device will allow an overcurrent low condition before output latches OFF occurs. Each output is independently selected for configuration based on the state of the D7 bit. A write to this register when bit 7 is logic [0] will configure the timeout for the HS0. Similarly, if D7 is logic [1] when this register is written, then HS1 is configured. Bits D1:D0 allow the MCU to select one of four fault blanking times defined in [Table 5](#), page 18. Note that these timeouts apply only to the overcurrent low detection levels. If the selected overcurrent high level is reached, the device will latch off within 20 μs.

Table 5. Overcurrent Low Detection Blanking Time

OCLT[1:0]	Timing
00	155 ms
01	10 ms
10	1.2 ms
11	150 μ s

A logic [1] on bit D2 disables the overcurrent low (CD) detection timeout feature. A logic [1] on bit D3 disables the open load (OL) detection feature.

Address x100—Direct Input Control Register (DICR)

The DICR register is used by the MCU to enable, disable, or configure the direct IN terminal control of each output. Each output is independently selected for configuration based on the state of bit D7. A write to this register when bit D7 is logic [0] will configure the direct input control for the HS0. Similarly, if D7 is logic [1] when this register is written, then HS1 is configured.

A logic [0] on bit D1 will enable the output for direct control by the IN terminal. A logic [1] on bit D1 will disable the output from direct control. While addressing this register, if the input was enabled for direct control, a logic [1] for the D0 bit will result in a Boolean AND of the IN terminal with its corresponding D0 message bit when addressing the OCR register. Similarly, a logic [0] on the D0 terminal results in a Boolean OR of the IN terminal with the corresponding message bits when addressing the OCR register.

The DICR register is useful if there is a need to independently turn on and off several loads that are PWM'd at the same frequency and duty cycle with only one PWM signal. This type of operation can be accomplished by connecting the pertinent direct IN terminals of several devices to a PWM output port from the MCU and configuring each of the outputs to be controlled via their respective direct IN terminal. The DICR is then used to Boolean AND the direct IN(s) of each of the outputs with the dedicated SPI bit that also controls the output. Each configured SPI bit can now be used to enable and disable the common PWM signal from controlling its assigned output.

A logic [1] on bit D2 is used to select the high ratio (C_{SR1} , 1/41000) on the CSNS terminal for the selected output. The default value [0] is used to select the low ratio (C_{SR0} , 1/20500). A logic [1] on bit D3 is used to select the high speed slew rate for the selected output. The default value [0] corresponds to the low speed slew rate.

Address 0101—Output Switching Delay Register (OSDR)

The OSDR register configures the device with a programmable time delay that is active during Output ON transitions initiated via SPI (not via direct input).

A write to this register configures both outputs for different delay. Whenever the input is commanded to transition from logic [0] to logic [1], both outputs will be held OFF for the time delay configured in the OSDR. The programming of the contents of this register have no effect on device fail-safe mode operation. The default value of the OSDR register is 000, equating to no delay. This feature allows the user a way to minimize inrush currents, or surges, thereby allowing loads to be switched ON with a single command. There are eight selectable output switching delay times that range from 0 ms to 525 ms (refer to [Table 6](#)).

Table 6. Switching Delay

OSD[2:0] (D2:D0)	Turn ON Delay (ms) HS0	Turn ON Delay (ms) HS1
000	0	0
001	75	0
010	150	150
011	225	150
100	300	300
101	375	300
110	450	450
111	525	450

Address 1101—Watchdog Register (WDR)

The WDR register is used by the MCU to configure the watchdog timeout. Watchdog timeout is configured using bits D1:D0. When D1:D0 bits are programmed for the desired watchdog timeout period, the WD bit (D7) should be toggled as well, ensuring the new timeout period is programmed at the beginning of a new count sequence (refer to [Table 7](#)).

Table 7. Watchdog Timeout

WD[1:0] (D1:D0)	Timing (ms)
00	620
01	310
10	2500
11	1250

Address 0110—No Action Register (NAR)

The NAR register can be used to no-operation fill SPI data packets in a daisy chain SPI configuration. This allows devices to not be affected by commands being clocked over a daisy-chained SPI configuration, and by toggling the WD bit (D7), the watchdog circuitry will continue to be reset while no programming or data readback functions are being requested from the device.

Address 1110—Undervoltage/Overvoltage Register (UOVR)

The UOVR register can be used to disable or enable overvoltage and/or undervoltage protection. By default (logic [0]), both protections are active. When disabled, an undervoltage or overvoltage condition fault will not be reported in the output fault register.

Address x111—TEST

The TEST register is reserved for test and is not accessible with SPI during normal operation.

Serial Output Communication (Device Status Return Data)

When the \overline{CS} terminal is pulled low, the output status register is loaded. Meanwhile, the data is clocked out MSB- (OD7-) first as the new message data is clocked into the SI terminal. The first eight bits of data clocking out of the SO, and following a \overline{CS} transition, are dependant upon the previously written SPI word.

Any bits clocked out of the SO terminal after the first eight will be representative of the initial message bits clocked into the SI terminal since the \overline{CS} terminal first transitioned to a logic [0]. This feature is useful for daisy chaining devices as well as message verification.

A valid message length is determined following a \overline{CS} transition of logic [0] to logic [1]. If there is a valid message length, the data is latched into the appropriate registers. A valid

message length is a multiple of eight bits. At this time, the SO terminal is tri-stated and the fault status register is now able to accept new fault status information.

The output status register correctly reflects the status of the STATR-selected register data at the time that the \overline{CS} is pulled to a logic [0] during SPI communication and/or for the period of time since the last valid SPI communication, with the following exceptions:

- The previous SPI communication was determined to be invalid. In this case, the status will be reported as though the invalid SPI communication never occurred.
- Battery transients below 6.0 V resulting in an undervoltage shutdown of the outputs may result in incorrect data loaded into the status register. The SO data transmitted to the MCU during the first SPI communication following an undervoltage V_{PWR} condition should be ignored.
- The \overline{RST} terminal transition from a logic [0] to logic [1] while the WAKE terminal is at logic [0] may result in incorrect data loaded into the status register. The SO data transmitted to the MCU during the first SPI communication following this condition should be ignored.

Serial Output Bit Assignment

The 8 bits of serial output data depend on the previous serial input message, as explained in the following paragraphs. [Table 8](#) summarizes the SO register content.

Table 8. Serial Output Bit Map Description

Previous STATR D7, D2, D1, D0				Serial Output Returned Data							
SOA3	SOA2	SOA1	SOA0	OD7	OD6	OD5	OD4	OD3	OD2	OD1	OD0
s	0	0	0	s	OTFs	OCHF _s	OCLF _s	OLF _s	UVF	OVF	FAULT _s
x	0	0	1	x	0	0	1	CSNS1 \overline{EN}	IN1_SPI	CSNS0 \overline{EN}	IN0_SPI
s	0	1	0	s	0	1	0	SOCH _s	SOCL2 _s	SOCL1 _s	SOCL0 _s
s	0	1	1	s	0	1	1	OL DIS _s	CD DIS _s	OCLT1 _s	OCLT0 _s
s	1	0	0	s	1	0	0	FAST SR _s	CSNS high _s	IN DIS _s	A/O _s
0	1	0	1	0	1	0	1	FSM_HS0	OSD2	OSD1	OSD0
1	1	0	1	1	1	0	1	FSM_HS1	WDTO	WD1	WD0
0	1	1	0	0	1	1	0	IN1 Terminal	IN0 Terminal	FSI Terminal	WAKE Terminal
1	1	1	0	1	1	1	0	–	–	UV_dis	OV_dis
x	1	1	1	–	–	–	–	–	–	–	–

s = Selection of output: logic [0] = HS0, logic [1] = HS1.
x = Don't care.

Bit OD7 reflects the state of the watchdog bit (D7) addressed during the prior communication. The value of the previous D7 will determine which output the status information applies to for the Fault (FLTR), SOCHLR, CDTOLR, and DICR registers. SO data will represent information ranging from fault status to

register contents, user selected by writing to the STATR bits D2:D0. Note that the SO data will continue to reflect the information for each output (depending on the previous D7 state) that was selected during the most recent STATR write until changed with an updated STATR write.

Previous Address SOA[2:0]=000

If the previous three MSBs are 000, bits OD6:OD0 will reflect the current state of the Fault register (FLTR) corresponding to the output previously selected with the bit OD7 ([Table 9](#)).

Table 9. Fault Register

OD7	OD6	OD5	OD4	OD3	OD2	OD1	OD0
s	OTF	OCHF _s	OCLF _s	OLF _s	UVF	OVF	FAULT _s

- OD7 (s) = Selection of output: logic [0] = HS0, logic [1] = HS1.
- OD6 (OTF) = Overtemperature Flag.
- OD5 (OCHF_s) = Overcurrent High Flag. (This fault is latched.)
- OD4 (OCLF_s) = Overcurrent Low Flag. (This fault is latched.)
- OD3 (OLF_s) = Open Load Flag.
- OD2 (UVF) = Undervoltage Flag. (This fault is latched or not latched.)
- OD1 (OVF) = Overvoltage Flag.
- OD0 (FAULT_s) = This flag reports a fault and is reset by a read operation.

Note The \overline{FS} terminal reports a fault. For latched faults, this terminal is reset by a new Switch ON command (via SPI or direct input IN).

Previous Address SOA[2:0]=001

Data in bits OD1:OD0 contain CSNS0 \overline{EN} and IN0_SPI programmed bits, respectively. Data in bits OD3:OD2 contain CSNS0 \overline{EN} and IN0_SPI programmed bits, respectively.

Previous Address SOA[2:0]=010

The data in bit OD3 contain the programmed overcurrent high detection level (refer to [Table 4](#), page 17), and the data in bits OD2:OD0 contain the programmed overcurrent low detection levels (refer to [Table 3](#), page 17).

Previous Address SOA[2:0]=011

Data returned in bits OD1 and OD0 are current values for the overcurrent fault blanking time, illustrated in [Table 5](#), page 18. Bit OD2 reports if the overcurrent detection timeout feature is active. OD3 reports if the open load circuitry is active.

Previous Address SOA[2:0]=100

The returned data contain the programmed values in the DICR.

Previous Address SOA[2:0]=101

- SOA3 = 0. The returned data contain the programmed values in the OSDR. Bit OD3 (FSM_HS0) reflects the state of the output HS0 in the Fail-Safe mode after a watchdog timeout occurs.
- SOA3 = 1. The returned data contain the programmed values in the WDR. Bit OD2 (WDTO) reflects the status of the watchdog circuitry. If WDTO bit is logic [1], the watchdog has timed out and the device is in Fail-Safe mode. If WDTO is logic [0], the device is in Normal mode (assuming the device is powered and not in Sleep mode), with the watchdog either enabled or disabled. Bit OD3 (FSM_HS1) reflects the state of the output HS1 in the Fail-Safe mode after a watchdog timeout occurs.

Previous Address SOA[2:0]=110

- SOA3 = 0. OD3:OD0 return the state of the IN1, IN0, FSI, and WAKE terminals, respectively ([Table 10](#)).

Table 10. Terminal Register

OD3	OD2	OD1	OD0
IN1 Terminal	IN0 Terminal	FSI Terminal	WAKE Terminal

- SOA3 = 1. The returned data contain the programmed values in the UOVR. Bit OD1 reflects the state of the undervoltage protection and bit OD0 reflects the state of the overvoltage protection (refer to [Table 8](#), page 19).

Previous Address SOA[2:0]=111

Null Data. No previous register Read Back command received, so bits OD2:OD0 are null, or 000.

MODES OF OPERATION

The 33984 has four operating modes: Sleep, Normal, Fault, and Fail-Safe. [Table 11](#) summarizes details contained in succeeding paragraphs.

Table 11. Fail-Safe Operation and Transitions to Other 33984 Modes

Mode	\overline{FS}	WAKE	\overline{RST}	WDTO	Comments
Sleep	x	0	0	x	Device is in Sleep mode. All outputs are OFF.
Normal	1	x	1	No	Normal mode. Watchdog is active if enabled.
Fault	0	1	x	No	The device is currently in Fault mode. The faulted output(s) is (are) OFF.
	0	x	1		
Fail-Safe	1	0	1	Yes	Watchdog has timed out and the device is in Fail-Safe mode. The outputs are as configured with the RFS resistor connected to FSI. \overline{RST} and WAKE must be transitioned to logic [0] simultaneously to bring the device out of the Fail-Safe mode or momentarily tied the FSI terminal to ground.
	1	1	1		
	1	1	0		

x = Don't care.

Sleep Mode

The default mode of the 33984 is the Sleep mode. This is the state of the device after first applying battery voltage (V_{PWR}), prior to any I/O transitions. This is also the state of the device when the WAKE and \overline{RST} are both logic [0]. In the Sleep mode, the output and all unused internal circuitry, such as the internal 5.0 V regulator, are off to minimize current draw. In addition, all SPI-configurable features of the device are as if set to logic [0]. The device will transition to the Normal or Fail-Safe operating modes based on the WAKE and \overline{RST} inputs as defined in [Table 11](#).

Normal Mode

The 33984 is in Normal mode when:

- V_{PWR} is within the normal voltage range.
- \overline{RST} terminal is logic [1].
- No fault has occurred.

Fail-Safe Mode

Fail-Safe Mode and Watchdog

If the FSI input is not grounded, the watchdog timeout detection is active when either the WAKE or \overline{RST} input terminal transitions from logic [0] to logic [1]. The WAKE input is capable of being pulled up to V_{PWR} with a series of limiting resistance that limits the internal clamp current according to the specification.

The watchdog timeout is a multiple of an internal oscillator and is specified in [Table 7](#), page 18. As long as the WD bit (D7) of an incoming SPI message is toggled within the minimum watchdog timeout period (WDTO), based on the programmed value of the WDR the device will operate normally. If an internal watchdog timeout occurs before the WD bit, the device will revert to a Fail-Safe mode until the device is reinitialized.

During the Fail-Safe mode, the outputs will be ON or OFF depending upon the resistor RFS connected to the FSI terminal, regardless of the state of the various direct inputs and modes ([Table 12](#)). In this mode, the SPI register content is retained except for overcurrent high and low detection levels and timing, which are reset to their default value (SOCL, SOCH, and OCLT). Then the watchdog, overvoltage, overtemperature, and overcurrent circuitry (with default value) are fully operational.

Table 12. Output State During Fail-Safe Mode

RFS (k Ω)	High-Side State
0	Fail-Safe Mode Disabled
6.0	Both HS0 and HS1 OFF
15	HS0 ON, HS1 OFF
30	Both HS0 and HS1 ON

The Fail-Safe mode can be detected by monitoring the WDTO bit D2 of the WD register. This bit is logic [1] when the device is in fail-safe mode. The device can be brought out of the Fail-Safe mode by transitioning the WAKE and \overline{RST} terminals from logic [1] to logic [0] or forcing the FSI terminal to logic [0]. [Table 11](#) summarizes the various methods for resetting the device from the latched Fail-Safe mode.

If the FSI terminal is tied to GND, the Watchdog fail-safe operation is disabled.

Loss of V_{DD}

If the external 5.0 V supply is not within specification, or even disconnected, all register content is reset. The two outputs can still be driven by the direct inputs IN1:IN0. The 33984 uses the battery input to power the output MOSFET-related current sense circuitry and any other internal logic providing fail-safe device operation with no V_{DD} supplied. In this state, the watchdog, overvoltage, overtemperature, and overcurrent circuitry are fully operational with default values.

Fault Mode

The 33984 indicates the following faults as they occur by driving the \overline{FS} terminal to logic [0]:

- Overtemperature fault
- Open load fault
- Overcurrent fault (high and low)
- Overvoltage and undervoltage fault

The \overline{FS} terminal will automatically return to logic [1] when the fault condition is removed, except for Overcurrent and in some cases Undervoltage.

Fault information is retained in the fault register and is available (and reset) via the SO terminal during the first valid SPI communication (refer to [Table 9](#), page 20).

Overtemperature Fault (Non-Latching)

The 33984 incorporates overtemperature detection and shutdown circuitry in each output structure. Overtemperature detection is enabled when an output is in the ON state.

For the output, an overtemperature fault (OTF) condition results in the faulted output turning OFF until the temperature falls below the $T_{SD(HYS)}$. This cycle will continue indefinitely until action is taken by the MCU to shut OFF the output, or until the offending load is removed.

When experiencing this fault, the OTF fault bit will be set in the status register and cleared after either a valid SPI read or a power reset of the device.

Overvoltage Fault (Non-Latching)

The 33984 shuts down the output during an overvoltage fault (OVF) condition on the V_{PWR} terminal. The output remains in the OFF state until the overvoltage condition is removed. When experiencing this fault, the OVF fault bit is set in the bit OD1 and cleared after either a valid SPI read or a power reset of the device.

The overvoltage protection and diagnostic can be disabled through SPI (bit OV_dis).

Undervoltage Shutdown (Latching or Non-Latching)

The output latches OFF at some battery voltage between 5.0 V and 6.0 V. As long as the V_{DD} level stays within the normal specified range, the internal logic states within the device will be sustained. This ensures that when the battery level then returns above 6.0 V, the device can be returned to the state that it was in prior to the low V_{PWR} excursion. Once the output latches OFF, the outputs must be turned OFF and ON again to re-enable them. In the case IN1:IN0 = 0, this fault is non-latched.

The undervoltage protection and diagnostic can be disabled through SPI (bit UV_dis).

Open Load Fault (Non-Latching)

The 33984 incorporates open load detection circuitry on each output. Output open load fault (OLF) is detected and reported as a fault condition when that output is disabled (OFF). The open load fault is detected and latched into the status register after the internal gate voltage is pulled low enough to turn OFF the output. The OLF fault bit is set in the status register. If the open load fault is removed, the status register will be cleared after reading the register.

The open load protection can be disabled through SPI (bit OL_dis).

Overcurrent Fault (Latching)

The device has eight programmable overcurrent low detection levels (I_{OCL}) and two programmable overcurrent high detection levels (I_{OCH}) for maximum device protection. The two selectable, simultaneously active overcurrent detection levels, defined by I_{OCH} and I_{OCL} , are illustrated in [Figure 4](#), page 13. The eight different overcurrent low detect levels (I_{OCL0} : I_{OCL7}) are likewise illustrated in [Figure 4](#).

If the load current level ever reaches the selected overcurrent low detect level and the overcurrent condition exceeds the programmed overcurrent time period (t_{OCx}), the device will latch the effected output OFF.

If at any time the current reaches the selected I_{OCH} level, then the device will immediately latch the fault and turn OFF the output, regardless of the selected t_{OCL} driver.

For both cases, the device output will stay off indefinitely until the device is commanded OFF and then ON again.

Reverse Battery

The output survives the application of reverse voltage as low as -16 V. Under these conditions, the output's gates are enhanced to keep the junction temperature less than 150°C. The ON resistance of the output is fairly similar to that in the Normal mode. No additional passive components are required.

Ground Disconnect Protection

In the event the 33984 ground is disconnected from load ground, the device protects itself and safely turns OFF the output regardless the state of the output at the time of disconnection.

Freescale Semiconductor, Inc.

Soldering Information

The 33984 is packaged in a surface mount power package intended to be soldered directly on the printed circuit board.

The 33984 was qualified in accordance with JEDEC standards JESD22-A113-B and J-STD-020A. The recommended reflow conditions are as follows:

- Convection: 225°C +5.0/-0°C
- Vapor Phase Reflow (VPR): 215°C to 219°C
- Infrared (IR)/Convection: 225°C +5.0/-0°C

The maximum peak temperature during the soldering process should not exceed 230°C. The time at maximum temperature should range from 10 s to 40 s maximum.

Freescale Semiconductor, Inc.

PACKAGE DIMENSIONS

PNA SUFFIX
 16-TERMINAL PQFN
 NONLEADED PACKAGE
 CASE 1402-02
 ISSUE B

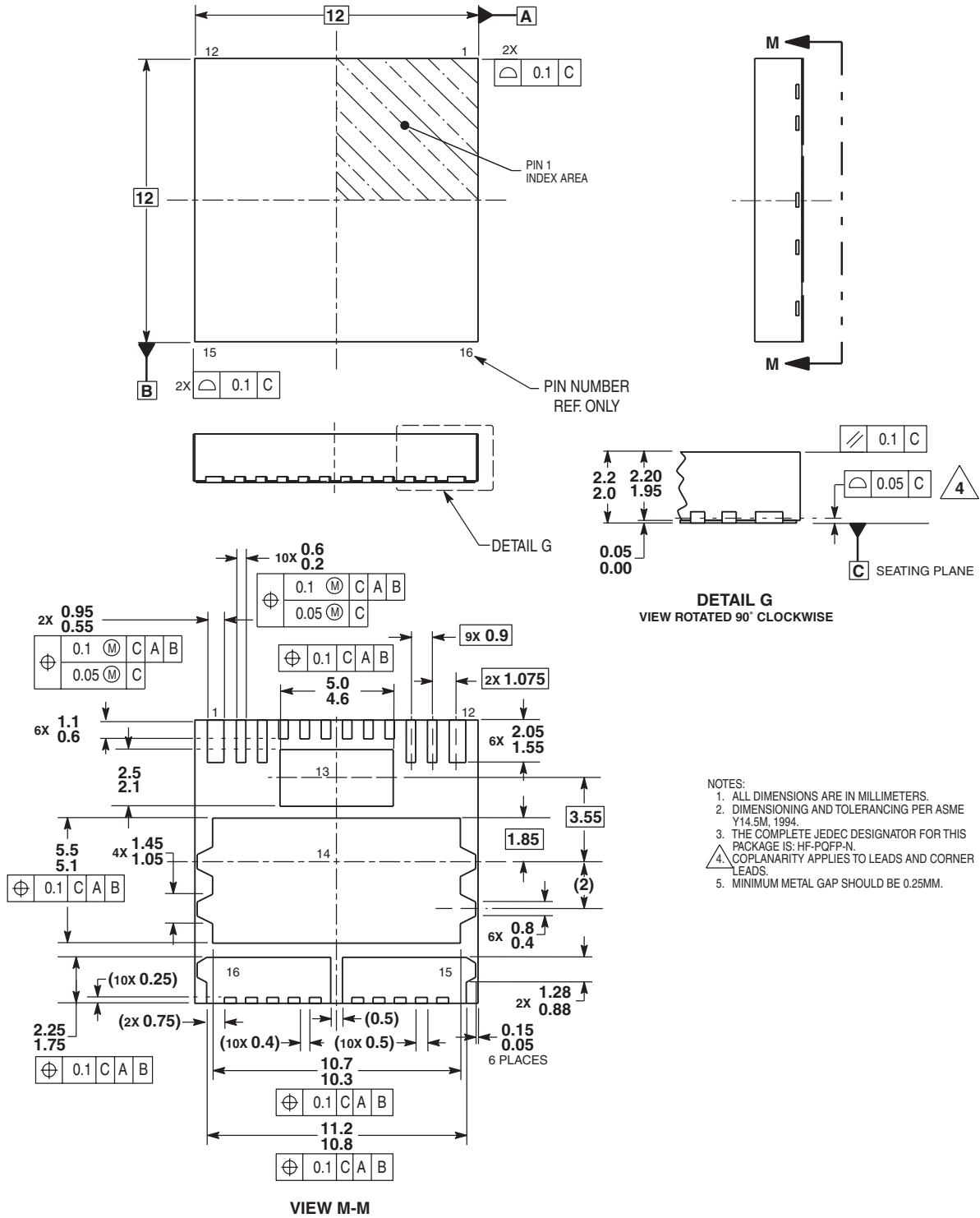

- NOTES:
1. ALL DIMENSIONS ARE IN MILLIMETERS.
 2. DIMENSIONING AND TOLERANCING PER ASME Y14.5M, 1994.
 3. THE COMPLETE JEDEC DESIGNATOR FOR THIS PACKAGE IS: HF-PQFP-N.
 4. COPLANARITY APPLIES TO LEADS AND CORNER LEADS.
 5. MINIMUM METAL GAP SHOULD BE 0.25MM.

NOTES

NOTES

NOTES

Freescale Semiconductor, Inc.

Freescale Semiconductor, Inc.

Information in this document is provided solely to enable system and software implementers to use Motorola products. There are no express or implied copyright licenses granted hereunder to design or fabricate any integrated circuits or integrated circuits based on the information in this document.

Motorola reserves the right to make changes without further notice to any products herein. Motorola makes no warranty, representation or guarantee regarding the suitability of its products for any particular purpose, nor does Motorola assume any liability arising out of the application or use of any product or circuit, and specifically disclaims any and all liability, including without limitation consequential or incidental damages. "Typical" parameters which may be provided in Motorola data sheets and/or specifications can and do vary in different applications and actual performance may vary over time. All operating parameters, including "Typicals" must be validated for each customer application by customer's technical experts. Motorola does not convey any license under its patent rights nor the rights of others. Motorola products are not designed, intended, or authorized for use as components in systems intended for surgical implant into the body, or other applications intended to support or sustain life, or for any other application in which the failure of the Motorola product could create a situation where personal injury or death may occur. Should Buyer purchase or use Motorola products for any such unintended or unauthorized application, Buyer shall indemnify and hold Motorola and its officers, employees, subsidiaries, affiliates, and distributors harmless against all claims, costs, damages, and expenses, and reasonable attorney fees arising out of, directly or indirectly, any claim of personal injury or death associated with such unintended or unauthorized use, even if such claim alleges that Motorola was negligent regarding the design or manufacture of the part.

MOTOROLA and the Stylized M Logo are registered in the US Patent and Trademark Office. All other product or service names are the property of their respective owners.

© Motorola, Inc. 2004

HOW TO REACH US:

USA/EUROPE/LOCATIONS NOT LISTED:

Motorola Literature Distribution
P.O. Box 5405, Denver, Colorado 80217
1-800-521-6274 or 480-768-2130

JAPAN: Motorola Japan Ltd.; SPS, Technical Information Center
3-20-1 Minami-Azabu, Minato-ku, Tokyo 106-8573, Japan
81-3-3440-3569

ASIA/PACIFIC: Motorola Semiconductors H.K. Ltd.; Silicon Harbour Centre
2 Dai King Street, Tai Po Industrial Estate, Tai Po, N.T., Hong Kong
852-26668334

HOME PAGE: <http://motorola.com/semiconductors>



MOTOROLA

**For More Information On This Product,
Go to: www.freescale.com**

MC33984