

1.9/2.1GHz LOW NOISE AMPLIFIER GaAs MMIC

■GENERAL DESCRIPTION

NJG1105F is a Low Noise Amplifier GaAs MMIC designed for 1.9/2.1GHz digital cellular phone handsets such as PCS and WCDMA.

This amplifier provides low noise figure, high gain and high IP3 operated by single low positive power supply.

■PACKAGE OUTLINE

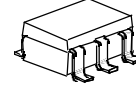

NJG1105F

■FEATURES

●Low voltage operation	+2.9V typ.
●Low current consumption	6mA typ.
●Small Package	MTP6 (Mount Size: 2.8x2.9x1.2mm)
[1.8GHz Band]	
●High small signal gain	20dB typ. @f=1860MHz
●Low Noise Figure	1.3dB typ. @f=1860MHz
●High Input IP3	-3dBm typ. @f=1860.0+1860.1MHz
[1.9GHz Band]	
●High small signal gain	20dB typ. @f=1960MHz
●Low Noise Figure	1.3dB typ. @f=1960MHz
●High Input IP3	-2dBm typ. @f=1960.0+1960.1MHz
[2.1GHz Band]	
●High small signal gain	16dB typ. @f=2140MHz
●Low Noise Figure	1.3dB typ. @f=2140MHz
●High Input IP3	0dBm typ. @f=2140.0+2140.1MHz

■PIN CONFIGURATION

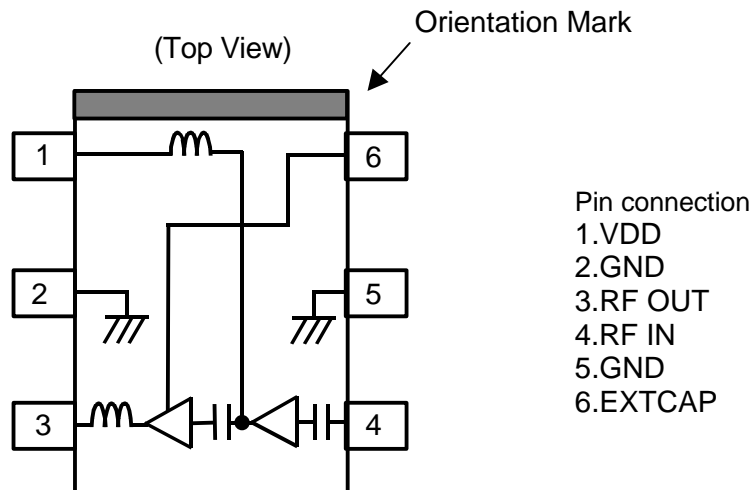

NJG1105F

■ABSOLUTE MAXIMUM RATINGS

($T_a=+25^{\circ}\text{C}$, $Z_s=Z_i=50\Omega$)

PARAMETER	SYMBOL	CONDITIONS	RATINGS	UNITS
Drain Voltage	V_{DD}		6.5	V
Input Power	P_{in}	$V_{DD}=2.9\text{V}$	+15	dBm
Power Dissipation	P_D		150	mW
Operating Temp.	T_{opr}		-40~+85	$^{\circ}\text{C}$
Storage Temp.	T_{stg}		-55~+125	$^{\circ}\text{C}$

■ELECTRICAL CHARACTERISTICS 1 (1.8GHz Band)

($V_{DD}=2.9\text{V}$, $f=1860\text{MHz}$, $T_a=+25^{\circ}\text{C}$, $Z_s=Z_i=50\Omega$)

PARAMETER	SYMBOL	CONDITIONS	MIN	TYP	MAX	UNITS
Operating Frequency	Freq		1840	1860	1870	MHz
Drain Voltage	V_{DD}		2.7	2.9	5.5	V
Operating Current	I_{DD}	RF OFF	-	6.0	8.0	mA
Small Signal Gain	Gain		17.0	20.0	23.0	dB
Gain Flatness	G_{flat}	$f=1840\sim 1870\text{MHz}$	-	0.5	1.0	dB
Noise Figure	NF		-	1.3	1.6	dB
Pout at 1dB Gain Compression point	P_{-1dB}		+2.0	+4.0	-	dBm
Input 3rd Order Intercept Point	IIP3	$f=1860.0+1860.1\text{MHz}$	-5.0	-3.0	-	dBm
Output 3rd Order Intercept Point	OIP3	$f=1860.0+1860.1\text{GHz}$	+15	+17		
LNAIN Port VSWR	$VSWR_i$		-	1.5	2.0	
LNAOUT Port VSWR	$VSWR_o$		-	1.5	2.0	
STABILITY		Input and output terminal: open or short, No RF input, $T_a=20\sim 80^{\circ}\text{C}$, freq<20GHz	Spurious: -60dBm max. No return gain			

NOTE: External circuits are required to get electrical characteristics Above at specified frequency.

■ ELECTRICAL CHARACTERISTICS 2 (1.9GHz Band)

($V_{DD}=2.9V$, $f=1960MHz$, $T_a=+25^{\circ}C$, $Z_s=Z_l=50\Omega$)

PARAMETER	SYMBOL	CONDITIONS	MIN	TYP	MAX	UNITS
Operating Frequency	Freq		1930	1960	1990	MHz
Drain Voltage	V_{DD}		2.7	2.9	5.5	V
Operating Current	I_{DD}	RF OFF	-	6.0	8.0	mA
Small Signal Gain	Gain		17.0	20.0	23.0	dB
Gain Flatness	G_{flat}	$f=1930\sim 1990MHz$	-	0.5	1.0	dB
Noise Figure	NF		-	1.3	1.6	dB
Pout at 1dB Gain Compression point	P_{-1dB}		+3.0	+5.0	-	dBm
Input 3rd Order Intercept Point	IIP3	$f=1960.0+1960.1MHz$	-4.0	-2.0	-	dBm
Output 3rd Order Intercept Point	OIP3	$f=1960.0+1960.1MHz$	+16	+18		
LNAIN Port VSWR	$VSWR_i$		-	1.5	2.0	
LNAOUT Port VSWR	$VSWR_o$		-	1.5	2.0	
STABILITY		Input and output terminal: open or short, No RF input, $T_a=20\sim 80^{\circ}C$, $freq < 20GHz$	Spurious: -60dBm max. No return gain			

NOTE: External circuits are required to get electrical characteristics
Above at specified frequency.

NJG1105F

■ELECTRICAL CHARACTERISTICS 3 (2.1GHz Band)

($V_{DD}=2.9V$, $f=2140MHz$, $T_a=+25^{\circ}C$, $Z_s=Z_l=50\Omega$)

PARAMETER	SYMBOL	CONDITIONS	MIN	TYP	MAX	UNITS
Operating Frequency	Freq		2110	2140	2170	MHz
Drain Voltage	V_{DD}		2.7	2.9	5.5	V
Operating Current	I_{DD}	RF OFF	-	6.0	8.0	mA
Small Signal Gain	Gain		13.0	16.0	19.0	dB
Gain Flatness	G_{flat}	$f=2110\sim 2140MHz$	-	0.5	1.0	dB
Noise Figure	NF		-	1.3	1.6	dB
Pout at 1dB Gain Compression point	P_{-1dB}		+3.0	+5.0	-	dBm
Input 3rd Order Intercept Point	IIP3	$f=2140.0+2140.1MHz$	-2.0	0.0	-	dBm
Output 3rd Order Intercept Point	OIP3	$f=2140.0+2140.1MHz$	+17	+19		
LNAIN Port VSWR	$VSWR_i$		-	1.5	2.0	
LNAOUT Port VSWR	$VSWR_o$		-	1.5	2.0	
STABILITY		Input and output terminal: open or short, No RF input, $T_a=20\sim 80^{\circ}C$, $freq<20GHz$	Spurious: -60dBm max. No return gain			

NOTE: External circuits are required to get electrical characteristics Above at specified frequency.

PACKAGE OUTLINE (MTP6)

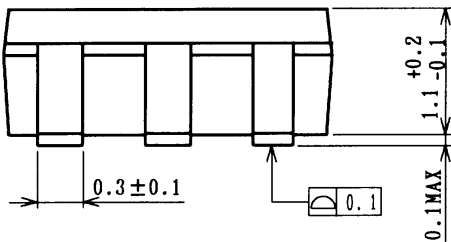
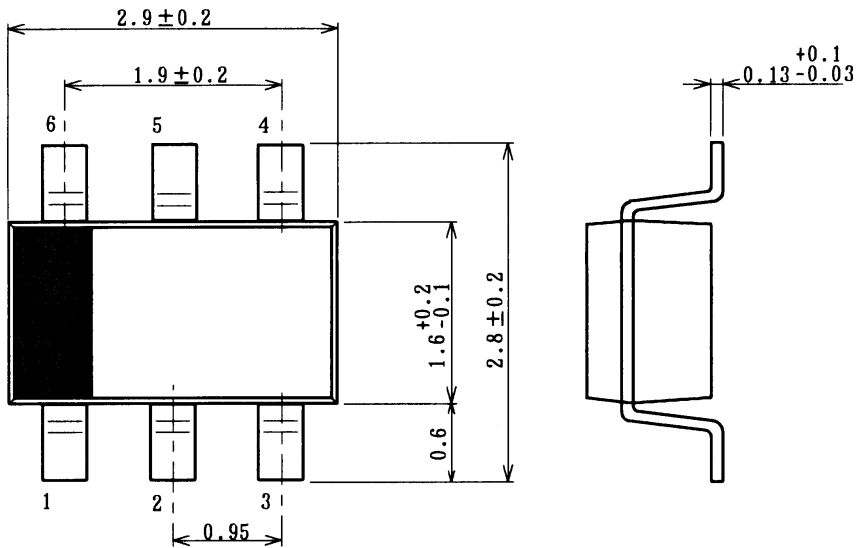

Lead material : Copper
 Lead surface finish : Solder plating
 Molding material : Epoxy resin
 Unit : mm
 Weight : 14mg

Cautions on using this product

This product contains Gallium-Arsenide (GaAs) which is a harmful material.

- Do NOT eat or put into mouth.
- Do NOT dispose in fire or break up this product.
- Do NOT chemically make gas or powder with this product.
- To waste this product, please obey the relating law of your country.

[CAUTION]

The specifications on this databook are only given for information, without any guarantee as regards either mistakes or omissions. The application circuits in this databook are described only to show representative usages of the product and not intended for the guarantee or permission of any right including the industrial rights.

This product may be damaged with electric static discharge (ESD) or spike voltage. Please handle with care to avoid these damages.