

## 8 PIN PWM SWITCHER CONTROLLER IC PRELIMINARY DATASHEET

### FEATURES

- 8 pin SOIC Switching Controller with HICCUP Current Limiting Reduces Diode Power Dissipation to Less than 1% of Normal Operation
- Soft Start Capacitor allows for smooth Output Voltage ramp up
- On board MOSFET driver
- Fastest transient response of any controller method. ( 0 to 100% Duty Cycle in 100 nS )
- 1% internal voltage reference
- Internal Under Voltage Lockout protects MOSFET during start-up

### APPLICATIONS

- Dual supply low voltage processor applications, such as: P55C™, CYRIX M2™, POWER PC™ and AMD K6™
- Simple 5V to 3.3V switcher for Pentium with AGP or Pentium II™ applications

### DESCRIPTION

The US3034 IC provides an 8 pin low cost switching controller with true short circuit protection all in a compact 8 pin surface mount package, providing a low cost switching solution for dual supply processor applications that require switching regulator for the 3.3V supply such as the applications with AGP on board. Typically in these applications a dual supply regulator converts 5V to 3.3V for I/O supply and a jumper programmable supply of 1.25V to 3.5V for CORE supply . The IC uses an internal regulator generated from the 12V supply to power the controller as well as the 12V supply to drive the power MOSFET, allowing a low cost N channel MOSFET to be used. The IC also includes an error comparator for fast transient response, a precise voltage reference for setting the output voltage as well as a direct drive of the MOSFET for the minimum part count.

### TYPICAL APPLICATION

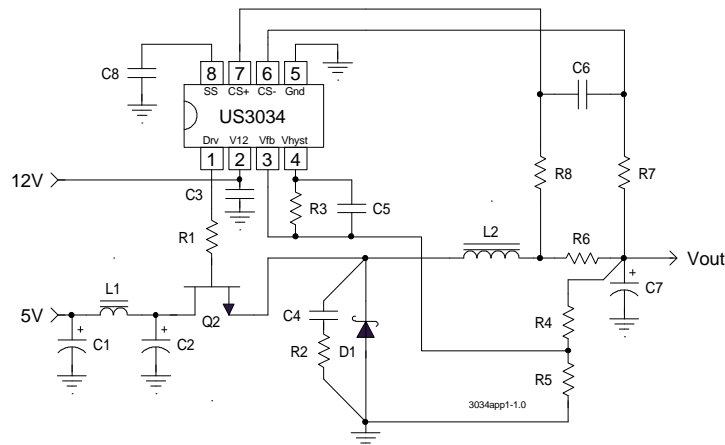

Typical application of US3034

Notes: P55C, Pentium II are trade marks of Intel Corp. K5 & K6 are trade marks of AMD corp. Cyrix 6X86L, M1, M2 are trade marks of Cyrix Corp. Power PC is trade mark of IBM Corp.

### PACKAGE ORDER INFORMATION

TA (°C)	8 PIN PLASTIC SOIC (S)
0 TO 70	US3034CS

# US3034

## ABSOLUTE MAXIMUM RATINGS

V <sub>12</sub> Supply Voltages .....	20V
F.B Pin Voltages.....	-0.3V to 5V
Storage Temperature Range .....	-65 TO 150°C
Operating Junction Temperature .....	0 TO 150°C

## PACKAGE INFORMATION

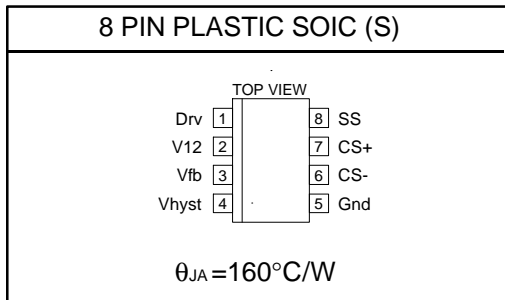

## ELECTRICAL SPECIFICATIONS

Unless otherwise specified the following specification applies over V<sub>12</sub> = 12V, and T<sub>A</sub> = 0 to 70°C. Low duty cycle pulse testing are used which keeps junction and case temperatures equal to the ambient temperature.

PARAMETER	SYM	TEST CONDITION	MIN	TYP	MAX	UNITS
F.B Voltage Initial Accuracy	V <sub>FB</sub>	T <sub>J</sub> = 25°C	1.237	1.250	1.262	V
F.B Voltage Total Variation			1.225	1.250	1.275	V
F.B Voltage Line Regulation				0.2		%
F.B Input Bias Current	I <sub>FB</sub>	V <sub>FB</sub> = 1.25V	-1		+1	uA
Min On Time		V <sub>FB</sub> is sq wave with 300 ns on time and 2 uS off time		800		nS
Min Off Time		V <sub>FB</sub> is sq wave with 300 ns off time and 2 uS on time		800		nS
Vhyst pin output-HI		I <sub>SOURCE</sub> = 500uA, V <sub>FB</sub> = 1.5V	11			V
Vhyst pin output-LO		I <sub>SINK</sub> = 500uA, V <sub>FB</sub> = 1V			1	V
Supply Current	I <sub>12SW</sub>	V <sub>FB</sub> = 1V		10		mA
Maximum Duty Cycle	D <sub>MAX</sub>	V <sub>FB</sub> = 1V			100	%
Minimum Duty Cycle	D <sub>MIN</sub>	V <sub>FB</sub> = 1.5V	0			%
Gate Drive Rise/Fall Time	V <sub>GATE</sub>	Load=IRL3303		70		nS
C.L Threshold Current	I <sub>CL</sub>	C.S+, C.S- from 1.3V to 3.7V		20		uA
C.S Comp Common Mode		V <sub>CS+</sub> = V <sub>CS-</sub>	0		4.5	V
Soft Start Current				10		uA

PIN DESCRIPTIONS

PIN #	PIN SYMBOL	PIN DESCRIPTION
3	V <sub>FB</sub>	A resistor divider from this pin to the output of the switching regulator and ground sets the Core supply voltage.
6	C.S-	This pin is connected to the minus side of the external current sense resistor. An internal current source together with an external resistor in series with this pin programs the current limit threshold voltage. This voltage divided by the external current sense resistor sets the current limit threshold.
7	C.S+	This pin is connected to the plus side of the external current sense resistor. A resistor in series with this pin and a capacitor connected between this pin and pin 6 provides a high frequency filtering for the noise spikes of turn on and turn off switching.
5	Gnd	This pin is connected to the IC substrate and must be connected to the lowest potential in the system.
1	Drv	The PWM output of the switching controller. This pin is a totem pole drive that is connected to the gate of the power MOSFET. A resistor may be placed from this pin to the gate in order to reduce switching noise.
4	V <sub>HYST</sub>	A resistor and a 10pF capacitor is connected from this pin to the V <sub>FB1</sub> pin to set the output ripple voltage for the switching regulator.
2	V <sub>12</sub>	This pin supplies the voltage to the PWM drive and hysterises circuitry and it is connected to the 12V supply. A 1 uF, high frequency capacitor must be connected from this pin to ground to provide the peak current for charging and discharging of the MOSFET.
8	S.S	This pin provides the soft start for the regulator during power up. It also sets a long off time when the converter goes into current limiting, providing low duty cycle for the catch diode allowing it to survive during short circuit.

BLOCK DIAGRAM

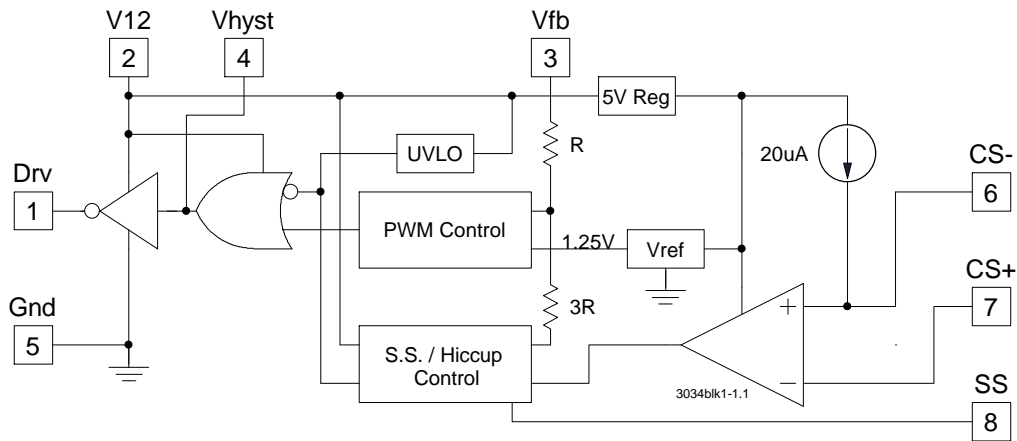

Figure 1 - Simplified block diagram of the US3034

# US3034

## TYPICAL APPLICATION

### Pentium Core Supply Application (US3034 and US3033 Dual Layout) Low Cost 4 Bit VID

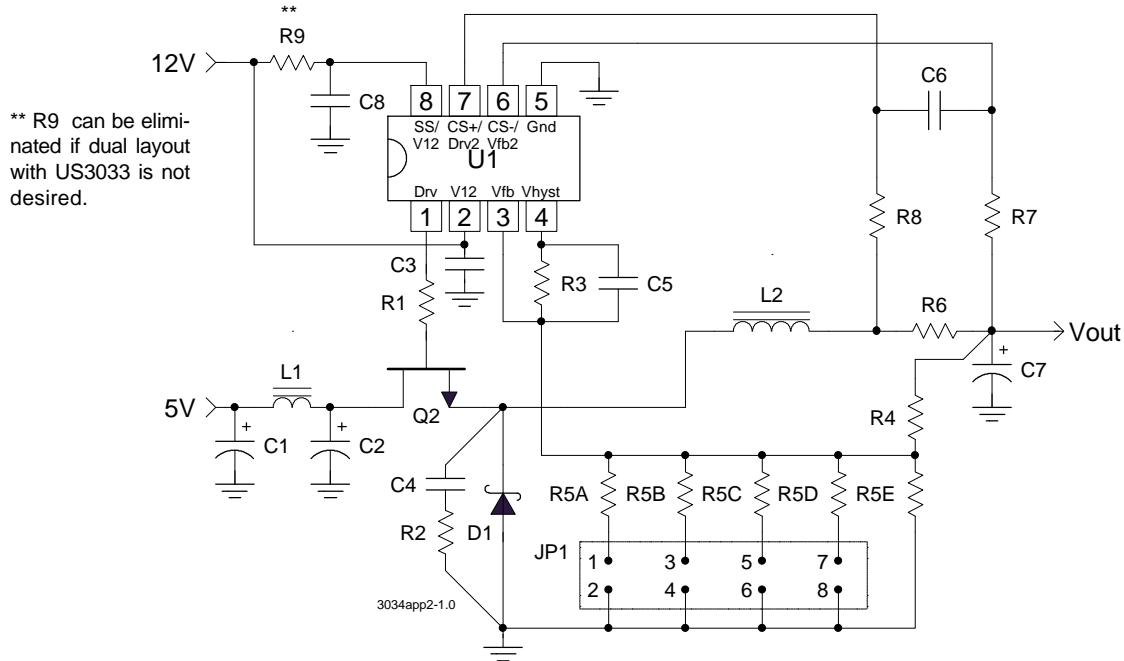

Figure2- Typical application of US3034 in a flexible motherboard with the 4 bit VID output voltage selection. This circuit is done using a dual layout with the US3033 part . The advantage of this circuit is that it uses a single jumper that programs the output voltage in 16 steps with 0.1V steps from 2V to 3.5V, designed for Intel P55,P54 AMD K5 & K6 as well as Cyrix M1 and M2 applications.

JP1	JP1	JP1	JP1	Output Voltage
1-2	3-4	5-6	7-8	
0	0	0	0	3.5
0	0	0	1	3.4
0	0	1	0	3.3
0	0	1	1	3.2
0	1	0	0	3.1
0	1	0	1	3.0
0	1	1	0	2.9
0	1	1	1	2.8
1	0	0	0	2.7
1	0	0	1	2.6
1	0	1	0	2.5
1	0	1	1	2.4
1	1	0	0	2.3
1	1	0	1	2.2
1	1	1	0	2.1
1	1	1	1	2.0

0 = Jumper block is installed.  
1 = Jumper block is not installed.

## Pentium Core Supply Application Parts List (US3034 and US3033 Dual Layout) Low Cost 4 Bit VID

Ref Desig	Description	Qty	Part #	Manufacturer
U1	LDO/Switcher IC	1	US3034CS ( 8 pin SOIC)	Unisem
Q2	MOSFET	1	IRL3303 (TO220) IRL3103S (TO263) (note 1)	International Rectifier
D1	Schottky Diode	1	MBR1045CT (TO220) MBRB1545CT (TO263) (note1)	Motorola
L2	Inductor	1	Core:T50-18,L=4 uH Turns: 10T, 18 AWG	Micro Metal (core)
L1	Inductor	1	L=2 uH	
R1	Resistor	1	22 ohm,5%, SMT 1206 size	
R2	Resistor	1	10 ohm, 5%, SMT 1206 size	
R3	Resistor	1	324 kohm,1%, SMT 0805 size	
R4A *	Resistor	1	806 ohm,1%, SMT 0805 size	
R4B *	Resistor	1	90.9 kohm,1%, SMT 0805 size	
R5A	Resistor	1	1.24 kohm,1%, SMT 0805 size	
R5B	Resistor	1	2.49 kohm,1%, SMT 0805 size	
R5C	Resistor	1	4.99 kohm,1%, SMT 0805 size	
R5D	Resistor	1	10 kohm,1%, SMT 0805 size	
R5E	Resistor	1	1.30 kohm,1%, SMT 0805 size	
R6	Resistor	1	5 miliohm,5%, 2W	
R7	Resistor	1	4.99 kohm,1%, SMT 0805 size	
R8	Resistor	1	4.7 kohm,5% for US3034, open for 3033	
R9	Resistor	1	open for US3034, 10 ohm for US3033	
C1	Capacitor	1	6MV1500GX, 1500uF,6.3V, Elect	
C2	Capacitor	1	6MV1500GX, 1500uF,6.3V, Elect	Sanyo
C3	Capacitor	1	1 uF,Ceramic, SMT 0805 size	
C4	Capacitor	1	470 pF,Ceramic, SMT 0805 size	Sanyo
C5	Capacitor	1	10 pF,Ceramic, SMT 0805 size	Sanyo
C7	Capacitor	4	6MV1500GX, 1500uF,6.3V, Elect	Sanyo
C8	Capacitor	1	0.047 uF for 3034 , 0.1uf for 3033	
C6	Capacitor	1	4700pF for US3034, open for US3033	
HS1	Heat Sink	1	For MOSFET , 577002	Aavid
HS2	Heat Sink	1	For Schottky Diode , 577002	Aavid

\* R4 is a parallel combination of R4A and R4B.

Note 1: For the applications where it is desirable to eliminate the heat sink, the IRL3103S for Q2 and MBR1545CT for D2 in TO263 packages with minimum of 1" square copper pad can be used.

# US3034

## TYPICAL APPLICATION

**5V to 3.3V for Pentium Application with AGP or Pentium II Application without ATX power supply  
Switching mode Operation. (US3034 and US3033 Dual Layout)**

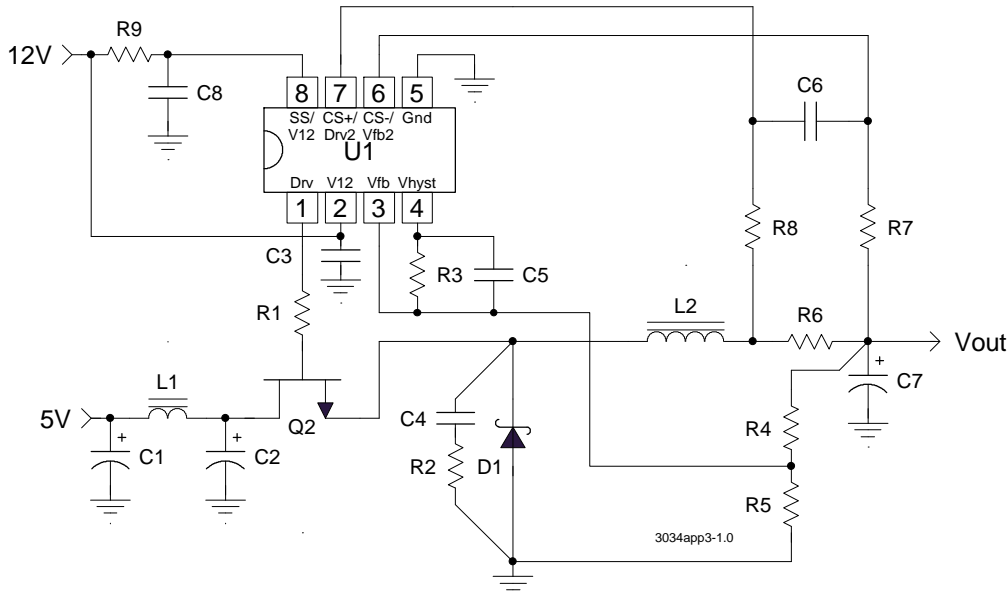

Figure4- The circuit in figure 4 is the application of the US3034 which is done using a dual layout with US3033 in a switching mode only. This circuit can be used to generate a low cost 5V to 3.3V for either Pentium application with AGP socket or in Pentium II applications where it is desirable to generate an accurate on board 3.3V supply.

Ref Desig	Description	Qty	Part #	Manufacturer
U1	LDO/Switcher IC	1	US3034CS ( 8 pin SOIC)	Unisem
Q2	MOSFET	1	IRL3303 (TO220) IRL3103S (TO263) (note 1)	International Rectifier
D1	Schottky Diode	1	MBR1045CT (TO220) MBRB1545CT (TO263) (note1)	Motorola
L2	Inductor	1	Core:T50-18,L=4 uH Turns: 10T, 18 AWG	Micro Metal (core)
L1	Inductor	1	L=2 uH	
R1	Resistor	1	22 ohm,5%, SMT 1206 size	
R9	Resistor	1	open for US3034, 10 ohm for US3033	
R2	Resistor	1	10 ohm, 5%, SMT 1206 size	
R3	Resistor	1	249 kohm,1%, SMT 0805 size	
R4	Resistor	1	1 kohm,1%, SMT 0805 size	
R5	Resistor	1	576 ohm,1%, SMT 0805 size	
R6	Resistor	1	5 miliohm,5%, 2W	
R7	Resistor	1	4.99 kohm,1%, SMT 0805 size	
R8	Resistor	1	4.7 kohm,5% for US3034, open for 3033	
C1,2	Capacitor	2	6MV1500GX, 1500uF,6.3V, Elect	Sanyo
C3	Capacitor	1	1 uF,Ceramic, SMT 0805 size	
C4	Capacitor	1	470 pF,Ceramic, SMT 0805 size	Sanyo
C5	Capacitor	1	10 pF,Ceramic, SMT 0805 size	Sanyo
C6	Capacitor	1	4700pF for US3034, open for US3033	
C7	Capacitor	2	6MV1500GX, 1500uF,6.3V, Elect	Sanyo
C8	Capacitor	1	0.047 uF for 3034 , 0.1uf for 3033	
HS1	Heat Sink	1	For MOSFET , 577002	Aavid
HS2	Heat Sink	1	For Schottky Diode , 577002	Aavid

Note 1: For the applications where it is desirable to eliminate the heat sink, the IRL3103S for Q2 and MBR1545CT for D2 in TO263 packages with minimum of 1" square copper pad can be used.

TYPICAL APPLICATION

5V to 3.3V with lossless short circuit protection(output UVLO detection).

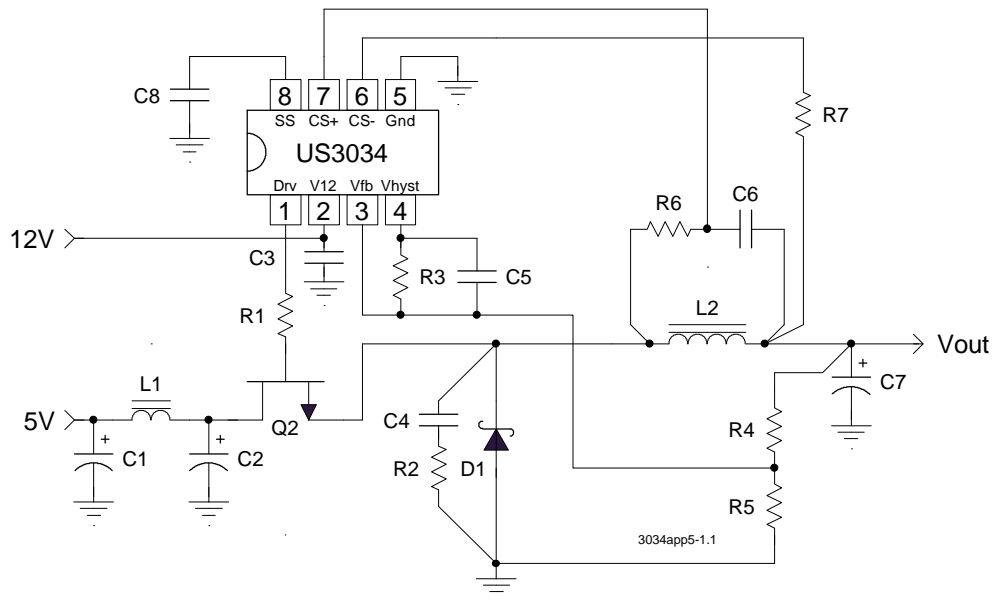

Figure 5- The circuit in figure 5 is designed to provide lossless output short detection by detecting the dc voltage across the inductor and shutting down the MOSFET and entering HICCUP mode. Note that the current limit point is a function of the inductor resistance and in this application with approximately 8 mil ohm resistance the peak C.L is set at 10A. See application note on how to set the current limiting threshold.

Ref Desig	Description	Qty	Part #	Manufacturer
U1	Switcher IC	1	US3034CS ( 8 pin SOIC)	Unisem
Q2	MOSFET	1	IRL3303 (TO263)	International Rectifier
D1	Schottky Diode	1	PBYR735(Axial Thr Hole pkg) PBYR1035B(SMT, TO263 pkg)	Motorola
L2	Inductor	1	Core:T50-18,L=4 uH Turns: 7T, 18 AWG	Micro Metal (core)
L1	Inductor	1	L=1 uH	
R1,2	Resistor	2	10 ohm,5%, SMT	
R3	Resistor	1	182 kohm,1%, SMT	
R4	Resistor	1	1 kohm,1%, SMT	
R5	Resistor	1	576ohm,1%, SMT	
R7	Resistor	1	3.83 kohm,1%, SMT	
R6	Resistor	1	1 kohm,1% , SMT	
C1	Capacitor	1	470uF, Elect	
C2	Capacitor	1	6MV1000GX, 1000uF,6.3V, Elect	Sanyo
C3	Capacitor	1	1 uF,Ceramic, SMT	
C5	Capacitor	1	10 pF,Ceramic, SMT	Sanyo
C6	Capacitor	1	0.1 uF	
C7	Capacitor	2	6MV1000GX, 1000uF,6.3V, Elect	Sanyo
C8	Capacitor	1	0.047 uF	

## APPLICATION INFORMATION

### Introduction

The US3034 device is an application specific product designed to provide an on board switching supply for the new generation of microprocessors requiring separate Core and I/O supplies where the load current demand from the I/O supply requires this regulator to also be a switching regulator such as the motherboard applications with AGP slot or the Pentium II with on board 5V to 3.3V converter. The US3034 provides an easy and low cost switching regulator solution for Vcore and 3.3V supplies with true short circuit protection.

### Switching Controller Operation

The operation of the switching controller is as follows : after the power is applied, the output drive pin, "Drv" goes to 100% duty cycle and the the current in the inductor charges the output capacitor causing the output voltage to increase. When output reaches a pre-programmed set point the feedback pin "Vfb" exceeds 1.25V causing the output drive to switch low and the "Vhyst" pin to switch high which jumps the feedback pin higher than 1.25V resulting in a fixed output ripple which is given by the following equation :

$$dV_o = (R_t/R_h) \times 11$$

Where:

$R_t$  = Resistor connected from Vout to the Vfb pin of US3034

$R_h$  = Resistor connected from Vfb pin to Vhyst pin.

For example, if  $R_t = 1k$  and  $R_h = 422k$ , then the output ripple is :

$$dV_o = (1/422) \times 11 = 26mV$$

The advantage of fixed output ripple is that when the output voltage changes from 2V to 3.5V, the ripple voltage remains the same which is important in meeting the Intel maximum tolerance specification.

### Soft Start

The soft start capacitor must be selected such that during the start up when the output capacitors are charging up, the peak inductor current does not reach the current limit threshold. A minimum of 0.1uF capacitor insures this for most applications. During start up the soft start capacitor is charged up to approximately 6V keeping the output shutdown before an internal 10uA current source start discharging the soft start capacitor which slowly ramps up the inverting input of the PWM comparator, Vfb. This insures the output to ramp up at the same rate as the soft start cap thereby limiting the input current. For example, with 0.1uF and the 10uA internal current source the ramp up rate is  $(\Delta V / \Delta t) = I / C_{ss} = 10 / 0.1 = 100V/Sec$  or 0.1V/mSec. Assuming that the output capacitance is 6000uF, the peak input current will be:  $I_{in(pk)} = C_{ss} \times (\Delta V / \Delta t) = 6000uF \times (0.1V/mSec) = 0.6A$

The soft start capacitor also provides a delay in the turn on of the output which is given by:

$$T_d = C_{ss} \times K$$

Where  $K = 30 \text{ ms/uF}$

For example for  $C_{ss} = 0.1 \text{ uF}$ ,

$$T_d = 0.1 \times 30 = 3 \text{ ms}$$

### Switcher Current Limit Protection

The US3034 uses an external current sensing resistor and compares the voltage drop across it to a programmed voltage which is set externally via a resistor ( $R_{CL}$ ) placed between the "CS-" terminal of the IC and Vout. Once the voltage across the sense resistor exceeds the threshold, the soft start capacitor pulls up to 12V, pulling up the inverting pin of the error comparator higher than non inverting which causes the external MOSFET to shut off. At this point the C.S comparator changes its state and pulls the soft start capacitor to Vcc which is 12V and shutting the PWM drive. After the output drive is turned off, an internal 10uA current source slowly discharge the soft start capacitor to approximately 5.7V, before the output starts to turn back on causing a long delay before the MOSFET turns back on. This delay causes the catch diode to cool off between the current limit cycles allowing the converter to survive a short circuit condition. An example is given below as how to select the current limiting components. Assuming the desired current limit point is set to be 20A and the current sense resistor  $R_s = 5m\Omega$ , then the current limit programming resistor,  $R_{CL}$  is calculated as :

$$V_{cs} = I_{cl} \times R_s = 20 \times 0.005 = 0.1V$$

$$R_{CL} = V_{cs} / I_b = (0.1V) / (20uA) = 5k\Omega$$

Where:  $I_b = 20uA$  is the internal current source of the US3034

The peak power dissipated in the C.S. resistor is :

$$P_{pk} = (I_{cl}^2) \times R_s = 20^2 \times 0.005 = 2W$$

However, the average power dissipated is much lower than 2W due to the long off time caused by the hiccup circuit of 3034. The average power is in fact the short circuit period divided by the short circuit period plus the off time or "hiccup" period. For example, if the short circuit lasts for  $T_{sc} = 100uSec$  before the 3034 enters hiccup, the average power is calculated as :

$$P_{ave} = 0.5 \times P_{pk} \times D_{sc}$$

Where:

$$D_{sc} = T_{sc} / T_{HCP}$$

$$T_{HCP} = C_{ss} \times M$$

Where  $M = 200 \text{ ms/uF}$  &  $C_{ss}$ , is the soft start capacitor

For example for  $C_{ss} = 0.1 \text{ uF}$  &  $T_{sc} = 500uSec = 0.5mS$

$$T_{HCP} = 0.1 \times 200 = 20 \text{ ms}$$

$$P_{ave} = 0.5 \times 2 \times (0.5/20) = 25 \text{ mW}$$

**Without "hiccup" technique, the power dissipation of the resistor is 2W.**



**Switcher Output Voltage Setting**

The output voltage can be set using the following equations.

Assuming,  $V_o=3.38V$  and the selected output ripple is  $\approx 1.3\%(44mV)$  of the output voltage, a set of equations are derived that selects the resistor divider and the hysteresis resistor.

Assuming,  $R_t=1k\Omega$ , 1%

$$R_h=(11 \cdot R_t)/\Delta V_o$$

Where:

$R_t$ =Top resistor of the resistor divider

$R_h$ =Hysteresis resistor connected between pins 3 and 4 of the US3034

$\Delta V_o$ =Selected output ripple (typically 1% to 2% of output voltage)

Assuming,  $\Delta V_o=44mV$

$$R_h=(11 \cdot 1000)/0.044=250 k\Omega$$

Select  $R_h=249 k\Omega$ , 1%

The bottom resistor of the divider is then calculated using the following equations:

$$R_b=R_t/X$$

Where:

$R_b$ =Bottom resistor of the divider

$$X=[(V_o + (\Delta V_o/2))/V_{ref}] - 1$$

$V_{ref}=1.25 V$  typ.

$$X=[(3.38 + (0.044/2))/1.25] - 1 = 1.72$$

$$R_b=1000/1.72=580 \Omega$$

Select  $R_b=576 \Omega$ , 1%

**Frequency Calculation**

The US3034 frequency of operation is calculated using the following formula:

$$F_s=[(V_o \cdot (1-D) \cdot ESR)]/(L \cdot \Delta V_o) \text{ (MHz)}$$

Where:

$V_o$ =Output voltage (V)

$D$ =Duty cycle

$ESR$ =Output capacitor ESR (V)

$L$ =Output inductance ( $\mu H$ )

$\Delta V_o$ =Output ripple voltage (V)

For our example:

$$D \approx (V_o + V_f)/V_{in}$$

Where,  $V_f$ =Forward voltage drop of the Schotky diode

$$D=(3.38 + 0.5)/5=0.78$$

The  $ESR=18m\Omega$  for 2 of the Sanyo 1500uF, 6MV1500GX caps. If  $L=3.5\mu H$  then,  $F_s$  is calculated as follows:

$$F_s=[(3.38 \cdot (1-0.78) \cdot 0.018)]/(3.5 \cdot 0.044) = 0.087 \text{ Mhz} =$$

87 kHz