

HETERO JUNCTION FIELD EFFECT TRANSISTOR
NE334S01

C BAND SUPER LOW NOISE AMPLIFIER
N-CHANNEL HJ-FET

DESCRIPTION

The NE334S01 is a Hetero Junction FET that utilizes the hetero junction to create high mobility electrons. Its excellent low noise and high associated gain make it suitable for TVRO and another commercial systems.

FEATURES

- Super Low Noise Figure & High Associated Gain
NF = 0.25 dB TYP., $G_a = 16.0$ dB TYP. at $f = 4$ GHz
- Gate Width: $W_g = 280 \mu\text{m}$

ORDERING INFORMATION

PART NUMBER	SUPPLYING FORM	MARKING
NE334S01-T1	Tape & reel 1000 pcs./reel	C
NE334S01-T1B	Tape & reel 4000 pcs./reel	

ABSOLUTE MAXIMUM RATINGS ($T_A = 25 \text{ }^\circ\text{C}$)

Drain to Source Voltage	V_{DS}	4.0	V
Gate to Source Voltage	V_{GS}	-3.0	V
Drain Current	I_D	I_{DSS}	mA
Total Power Dissipation	P_{tot}	300	mW
Channel Temperature	T_{ch}	125	$^\circ\text{C}$
Storage Temperature	T_{stg}	-65 to +125	$^\circ\text{C}$

RECOMMENDED OPERATING CONDITION ($T_A = 25 \text{ }^\circ\text{C}$)

CHARACTERISTIC	SYMBOL	MIN.	TYP.	MAX.	Unit
Drain to Source Voltage	V_{DS}		2	2.5	V
Drain Current	I_D		15	20	mA
Input Power	P_{in}			0	dBm

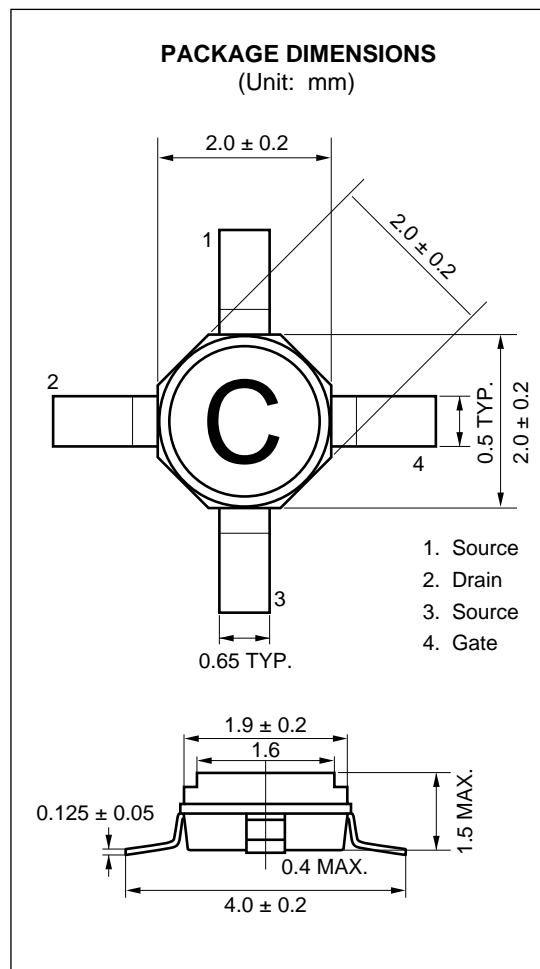

ELECTRICAL CHARACTERISTICS (T_A = 25 °C)

PARAMETER	SYMBOL	MIN.	TYP.	MAX.	UNIT	TEST CONDITIONS
Gate to Source Leak Current	I _{GS0}		0.5	10	μA	V _{GS} = -3 V
Saturated Drain Current	I _{DSS}	20	80	150	mA	V _{DS} = 2 V, V _{GS} = 0 V
Gate to Source Cutoff Voltage	V _{GS(off)}	-0.2	-0.9	-2.5	V	V _{DS} = 2 V, I _b = 100 μA
Transconductance	g _m	70	85		mS	V _{DS} = 2 V, I _b = 14 mA
Noise Figure	NF		0.25	0.35	dB	V _{DS} = 2 V, I _b = 15 mA,
Associated Gain	G _a	15.0	16.0		dB	f = 4 GHz

TYPICAL CHARACTERISTICS (T_A = 25 °C)

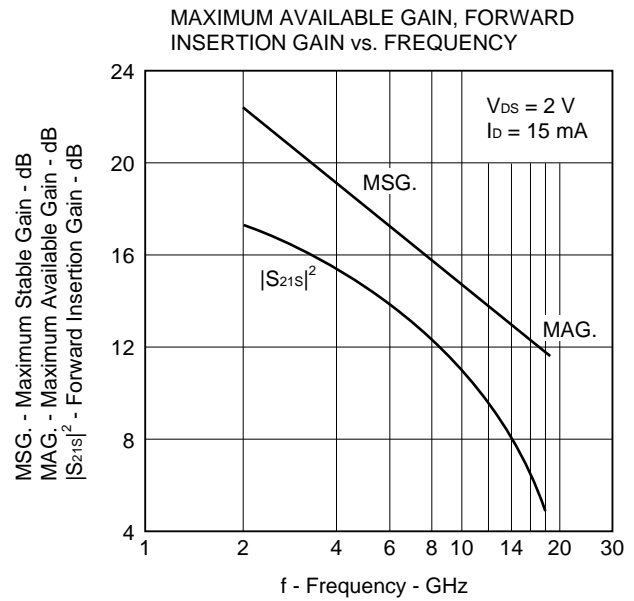
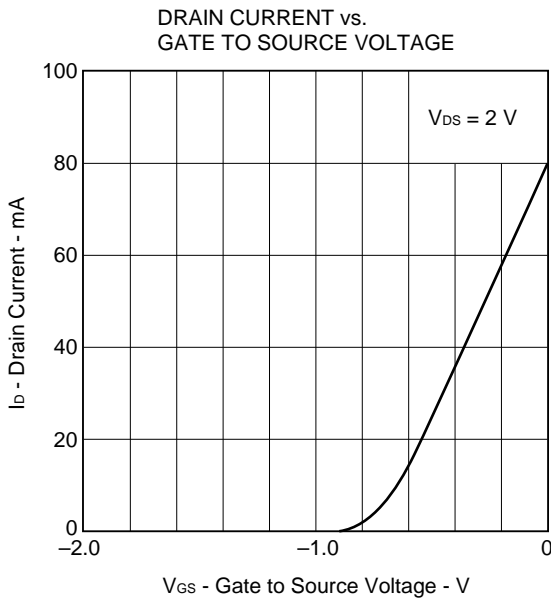
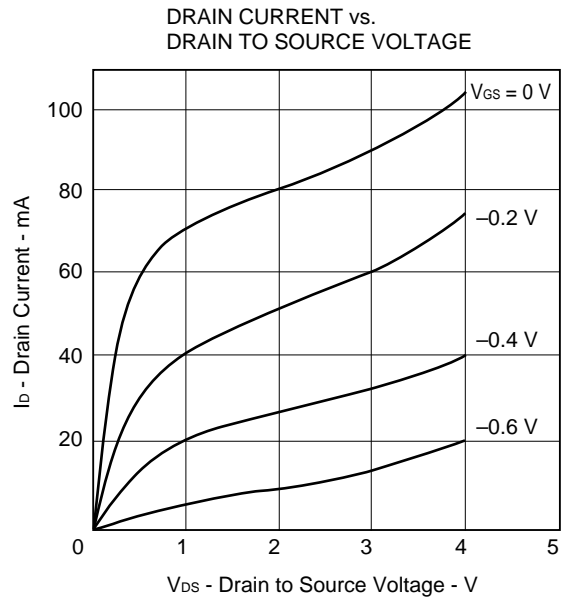
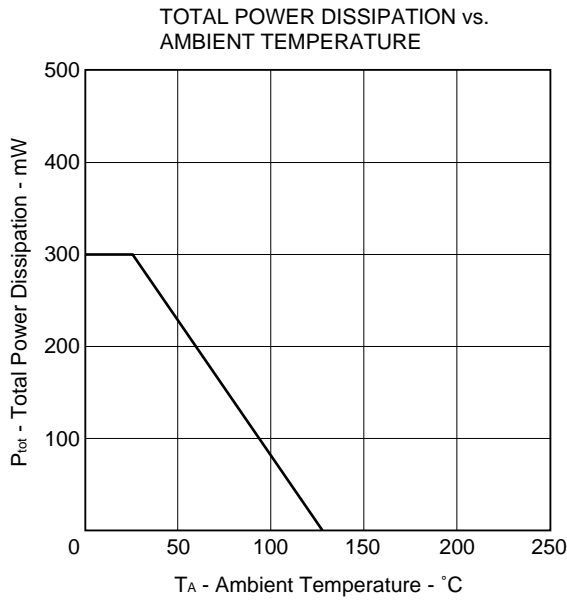

Gain Calculations

$$MSG = \frac{|S_{21}|}{|S_{12}|} \quad K = \frac{1 + |\Delta|^2 - |S_{11}|^2 - |S_{22}|^2}{2|S_{12}||S_{21}|}$$

$$MAG = \frac{|S_{21}|}{|S_{12}|} (K \pm \sqrt{K^2 - 1}) \quad \Delta = S_{11} \cdot S_{22} - S_{21} \cdot S_{12}$$

S-PARAMETERS

$V_{DS} = 2\text{ V}$, $I_D = 15\text{ mA}$

START 2 GHz, STOP 18 GHz, STEP 500 MHz

Marker
 1: 4 GHz
 2: 8 GHz
 3: 12 GHz
 4: 16 GHz
 5: 18 GHz

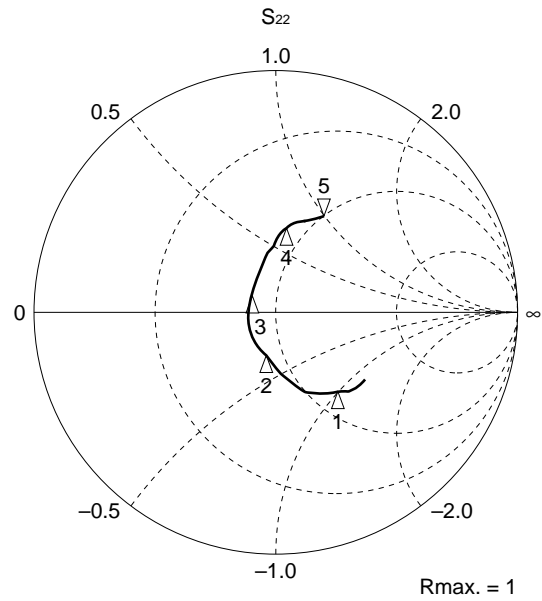
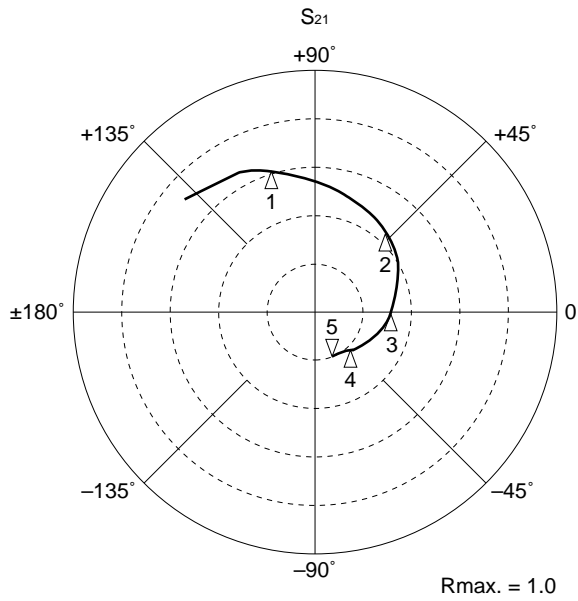
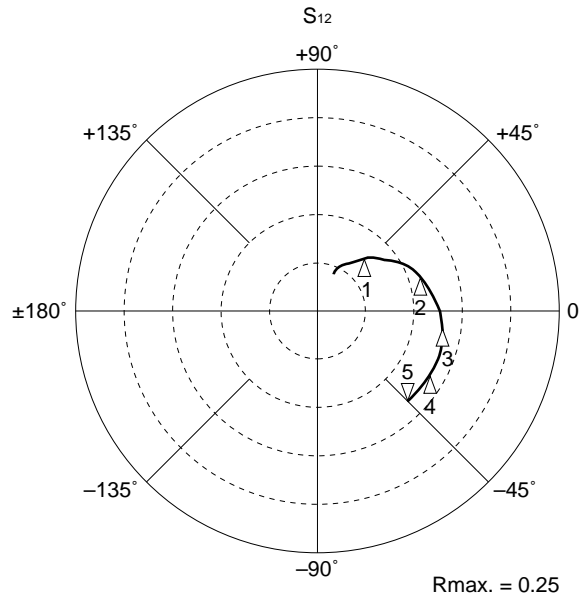
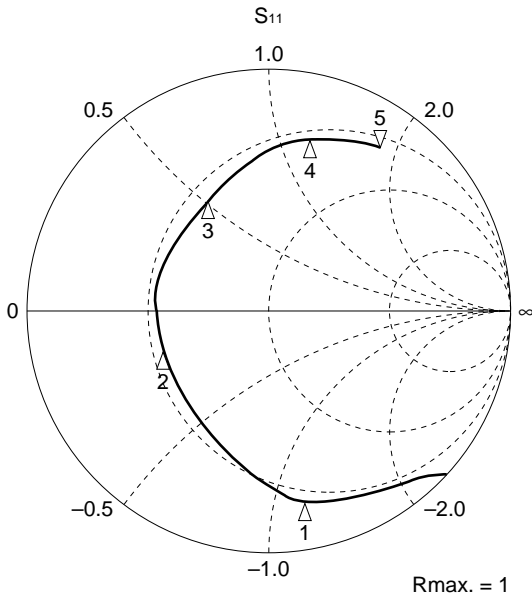

S-PARAMETERS

MAG. AND ANG.

V_{DS} = 2 V, I_D = 15 mA

FREQUENCY MHz	S ₁₁		S ₂₁		S ₁₂		S ₂₂	
	MAG.	ANG. (deg.)	MAG.	ANG. (deg.)	MAG.	ANG. (deg.)	MAG.	ANG. (deg.)
2000	.998	-41.7	7.162	140.1	.042	68.4	.415	-27.5
2500	.927	-47.5	6.856	133.6	.050	65.9	.479	-35.8
3000	.860	-61.3	6.603	122.0	.057	57.5	.423	-43.0
3500	.829	-69.9	6.305	114.4	.064	54.1	.429	-47.9
4000	.802	-79.2	6.033	106.8	.071	49.6	.426	-51.7
4500	.716	-87.5	5.687	98.5	.075	45.8	.406	-56.2
5000	.659	-93.9	5.415	91.6	.081	41.1	.394	-59.7
5500	.601	-99.7	5.184	84.7	.085	38.9	.374	-63.3
6000	.592	-108.5	5.050	77.6	.091	35.2	.340	-68.1
6500	.550	-118.5	4.912	70.5	.096	30.8	.311	-73.0
7000	.514	-130.2	4.774	63.0	.102	27.3	.279	-79.1
7500	.488	-144.5	4.600	55.4	.107	22.0	.232	-87.5
8000	.464	-158.9	4.401	47.9	.109	18.6	.189	-97.7
8500	.463	-171.7	4.187	41.0	.113	14.9	.155	-109.3
9000	.468	176.6	3.997	34.1	.114	11.5	.134	-126.9
9500	.472	166.4	3.812	27.7	.118	7.7	.121	-142.8
10000	.472	156.2	3.628	21.5	.119	4.7	.111	-156.2
10500	.476	147.0	3.477	15.6	.122	1.0	.103	-170.1
11000	.476	137.8	3.351	9.6	.124	-2.5	.098	174.4
11500	.488	127.7	3.251	3.5	.125	-5.8	.093	157.9
12000	.518	118.1	3.150	-2.9	.128	-9.2	.105	137.6
12500	.552	109.6	3.036	-9.7	.130	-12.9	.131	121.0
13000	.593	101.9	2.875	-16.4	.131	-16.7	.177	107.0
13500	.635	95.2	2.714	-22.7	.129	-21.2	.223	97.8
14000	.661	90.1	2.546	-28.1	.126	-22.5	.259	91.0
14500	.688	86.1	2.418	-32.6	.124	-24.9	.284	87.0
15000	.707	82.2	2.327	-37.0	.127	-27.4	.316	86.0
15500	.719	79.7	2.240	-41.8	.126	-28.8	.332	83.3
16000	.730	76.1	2.168	-46.8	.129	-31.6	.352	81.7
16500	.752	71.3	2.100	-52.7	.131	-33.2	.380	77.4
17000	.771	65.5	2.021	-58.4	.130	-38.5	.398	72.4
17500	.803	60.4	1.930	-65.1	.134	-42.2	.422	66.5
18000	.817	55.7	1.814	-70.5	.128	-44.3	.445	62.9

AMP. PARAMETERS

$V_{DS} = 2\text{ V}$, $I_D = 15\text{ mA}$

FREQUENCY MHz	GUmax dB	GAmax dB	S ₂₁ ² dB	S ₁₂ ² dB	K	Delay ns	Mason's U dB	G1 dB	G2 dB
2000	41.82		17.10	-27.61	.10	.036		23.90	.82
2500	26.36		16.72	-26.05	.23	.036		8.50	1.13
3000	23.09		16.39	-24.82	.39	.064		5.83	.86
3500	21.91		15.99	-23.94	.42	.042		5.04	.88
4000	20.95		15.61	-22.95	.45	.042		4.47	.87
4500	19.00		15.10	-22.49	.60	.046		3.12	.78
5000	17.88		14.67	-21.87	.69	.038	27.689	2.47	.73
5500	16.89		14.29	-21.41	.78	.038	25.567	1.94	.65
6000	16.47		14.07	-20.78	.79	.039	27.520	1.87	.54
6500	15.83		13.83	-20.36	.84	.040	25.660	1.56	.44
7000	15.26		13.58	-19.85	.87	.041	25.850	1.33	.35
7500	14.68		13.25	-19.40	.91	.043	24.669	1.18	.24
8000	14.08		12.87	-19.24	.96	.041	23.510	1.05	.16
8500	13.59		12.44	-18.94	.98	.039	23.291	1.05	.11
9000	13.19	15.01	12.03	-18.84	1.00	.038	23.059	1.08	.08
9500	12.78	14.21	11.62	-18.57	1.02	.036	22.736	1.09	.06
10000	12.34	13.37	11.19	-18.48	1.06	.034	21.540	1.09	.05
10500	11.99	12.86	10.82	-18.28	1.08	.033	20.889	1.12	.05
11000	11.66	12.36	10.50	-18.14	1.10	.033	19.984	1.12	.04
11500	11.46	12.06	10.24	-18.05	1.12	.034	19.642	1.18	.04
12000	11.37	11.98	9.97	-17.83	1.10	.035	20.331	1.36	.05
12500	11.30	11.92	9.65	-17.73	1.08	.038	20.980	1.58	.08
13000	11.19	11.79	9.17	-17.63	1.07	.037	21.543	1.88	.14
13500	11.14	11.70	8.67	-17.81	1.06	.035	21.748	2.25	.22
14000	10.92	11.29	8.12	-17.97	1.08	.030	20.156	2.50	.30
14500	10.82	11.17	7.67	-18.12	1.08	.025	19.965	2.79	.37
15000	10.80	11.30	7.33	-17.94	1.05	.025	21.257	3.00	.46
15500	10.67	11.20	7.01	-17.99	1.04	.027	20.523	3.15	.51
16000	10.60	11.55	6.72	-17.76	1.01	.028	21.974	3.30	.58
16500	10.74		6.45	-17.68	.98	.033	22.748	3.62	.68
17000	10.78		6.11	-17.72	.96	.032	25.818	3.92	.75
17500	11.05		5.71	-17.46	.89	.037		4.49	.85
18000	10.92		5.17	-17.88	.91	.030	27.860	4.78	.96

Noise Parameters

<TYPICAL CONSTANT NOISE FIGURE CIRCLE>

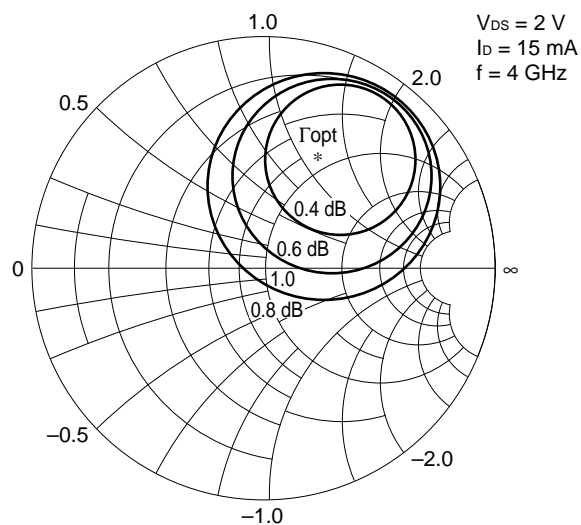

<Noise Parameters>

$V_{DS} = 2\text{ V}$, $I_D = 15\text{ mA}$

Freq (GHz)	NF _{min} (dB)	Ga (dB)	Γ _{opt.}		R _n /50
			MAG.	ANG. (deg.)	
2.0	0.23	17.0	0.77	15	0.19
4.0	0.25	16.0	0.58	43	0.18
6.0	0.28	14.7	0.43	82	0.13
8.0	0.31	13.6	0.32	127	0.08
10.0	0.38	12.5	0.27	175	0.07
12.0	0.48	11.5	0.27	-139	0.10
14.0	0.60	10.5	0.34	-100	0.17
16.0	0.73	9.6	0.48	-70	0.29
18.0	0.88	8.8	0.69	-56	0.46

TYPICAL MOUNT PAD LAYOUT

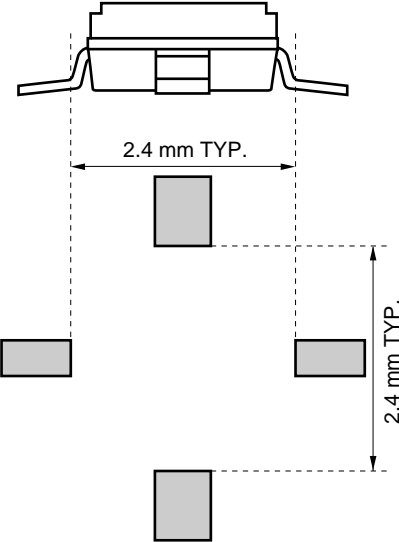

RECOMMENDED SOLDERING CONDITIONS

The following conditions (see table below) must be met when soldering this product.

Please consult with our sales offices in case other soldering process is used, or in case soldering is done under different conditions.

<TYPES OF SURFACE MOUNT DEVICE>

For more details, refer to our document "SEMICONDUCTOR DEVICE MOUNTING TECHNOLOGY MANUAL" (C10535E)

Soldering process	Soldering conditions	Symbol
Infrared ray reflow	Peak package's surface temperature: 230 °C or below, Reflow time: 30 seconds or below (210 °C or higher), Number of reflow process: 1, Exposure limit*: None	IR30-00
Partial heating method	Terminal temperature: 230 °C or below, Flow time: 10 seconds or below, Exposure limit*: None	

*: Exposure limit before soldering after dry-pack package is opened.

Storage conditions: 25 °C and relative humidity at 65 % or less.

Note: Do not apply more than a single process at once, except for "Partial heating method".

PRECAUTION: Avoid high static voltage and electric fields, because this device is Hetero Junction field effect transistor with shottky barrier gate.

[MEMO]

[MEMO]

Caution

**The Great Care must be taken in dealing with the devices in this guide.
The reason is that the material of the devices is GaAs (Gallium Arsenide), which is
designated as harmful substance according to the law concerned.
Keep the law concerned and so on, especially in case of removal.**

No part of this document may be copied or reproduced in any form or by any means without the prior written consent of NEC Corporation. NEC Corporation assumes no responsibility for any errors which may appear in this document.

NEC Corporation does not assume any liability for infringement of patents, copyrights or other intellectual property rights of third parties by or arising from use of a device described herein or any other liability arising from use of such device. No license, either express, implied or otherwise, is granted under any patents, copyrights or other intellectual property rights of NEC Corporation or others.

While NEC Corporation has been making continuous effort to enhance the reliability of its semiconductor devices, the possibility of defects cannot be eliminated entirely. To minimize risks of damage or injury to persons or property arising from a defect in an NEC semiconductor device, customers must incorporate sufficient safety measures in its design, such as redundancy, fire-containment, and anti-failure features.

NEC devices are classified into the following three quality grades:

"Standard", "Special", and "Specific". The Specific quality grade applies only to devices developed based on a customer designated "quality assurance program" for a specific application. The recommended applications of a device depend on its quality grade, as indicated below. Customers must check the quality grade of each device before using it in a particular application.

Standard: Computers, office equipment, communications equipment, test and measurement equipment, audio and visual equipment, home electronic appliances, machine tools, personal electronic equipment and industrial robots

Special: Transportation equipment (automobiles, trains, ships, etc.), traffic control systems, anti-disaster systems, anti-crime systems, safety equipment and medical equipment (not specifically designed for life support)

Specific: Aircrafts, aerospace equipment, submersible repeaters, nuclear reactor control systems, life support systems or medical equipment for life support, etc.

The quality grade of NEC devices is "Standard" unless otherwise specified in NEC's Data Sheets or Data Books. If customers intend to use NEC devices for applications other than those specified for Standard quality grade, they should contact an NEC sales representative in advance.

Anti-radioactive design is not implemented in this product.