

9325812 UNITED MICROELECTRONICS

92D 00427

D 7-75-67-67



UM9559E/F

Tone Dialer



Features

- Low output tone distortion: 7%
- Wide operating supply voltage range: 2.5 to 10.0 volts
- Uses TV crystal standard (3.58MHz) to derive all frequencies thus providing very high accuracy and stability
- Oscillator bias resistor on-chip
- Can be powered directly from telephone line or from small batteries
- Mute drivers on-chip
- On-chip generation of a reference voltage to assure amplitude stability
- Interfaces directly to a standard telephone push-button or calculator type XY keyboard
- Two options available on pin 15: bipolar output
E: mode select F: chip disable

General Description

The UM9559E/F DTMF TONE GENERATOR are specially designed to implement a dual tone telephone dialing system. The device can interface directly to a standard pushbutton telephone keyboard or calculator type XY keyboard and operates directly from the telephone lines. All necessary dual-tone frequencies are derived from the widely used TV crystal standard providing very high accuracy and stability. The required sinusoidal waveform for the individual tones is digitally synthesized on the chip. This waveform so generated has very low total harmonic distortion (7%). A voltage reference is generated on the chip which is stable over the operating voltage

and temperature range and regulates the signal levels of the dual tones to meet the recommended telephone industry specifications. These features permit the UM 9559E/F to be incorporated with a slight modification of the standard 500 type telephone basic circuitry to form a pushbutton dual-tone telephone. Other applications of the device include radio and mobile telephones, remote control, point of sale, and credit card verification terminals and process control. The UM9559E/F are pin and functionally compatible with the S2559C/E and S2559D/F, respectively.

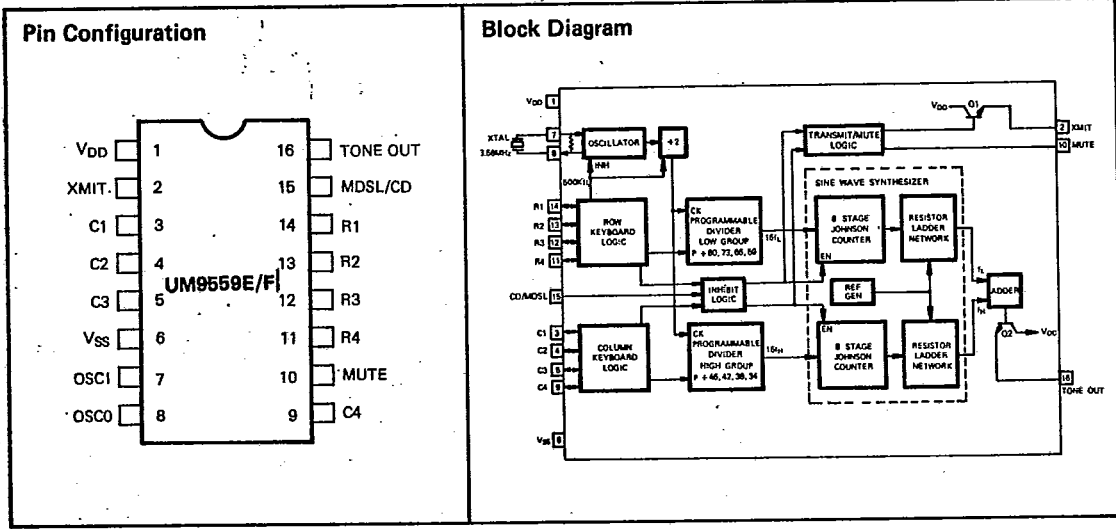

9325812 UNITED MICROELECTRONICS

92D 00428

D7-75-07-07



UM9559E/F

Absolute Maximum Ratings*

DC Supply Voltage ($V_{DD} - V_{SS}$) +10.5V
 Operating Temperature -25°C to +70°C
 Storage Temperature -30°C to +125°C
 Power Dissipation at 25°C 1000mW
 Digital Input $V_{SS} - 0.3 \leq V_{IN} \leq V_{DD} + 0.3$
 Analog Input $V_{SS} - 0.3 \leq V_{IN} \leq V_{DD} + 0.3$

***Comments**

Stresses above those listed under "Absolute Maximum Ratings" may cause permanent damage to the device. This is a stress rating only and functional operation of the device at these or any other conditions above those indicated in the operational sections of this specification is not implied.

Electrical Characteristics

(Specifications apply over the operating temperature range of -25°C to +70°C unless otherwise noted. Absolute values of measured parameters are specified.)

Parameter	Symbol	Min.	Typ.	Max.	Units	Conditions
OPERATING VOLTAGE						
Tone Out Mode	V_{DD}	2.5		10.0	V	Valid Key Depressed
Non Tone Out Mode	V_{DD}	2.0		10.0	V	No Key Depressed
OPERATING CURRENT						
Standby Mode	I_{DD}		0.3	30	μA	$V_{DD} = 3.0V$ No Key Selected, Tone, XMIT and MUTE Outputs Unloaded
	I_{DD}		1.0	100	μA	$V_{DD} = 10.0V$ No Key Selected, Tone, XMIT and MUTE Outputs Unloaded
Operating Mode	I_{DD}		1.0	2.0	mA	$V_{DD} = 3.0V$ One Key Selected, Tone, XMIT and MUTE Outputs Unloaded
	I_{DD}		8	16.0	mA	$V_{DD} = 10.0V$ One Key Selected, Tone, XMIT and MUTE Outputs Unloaded
Single Tone Mode Output Voltage	V_{OR}	335	465	565	mVrms	$V_{DD} = 3.5V$ Row Tone, $R_L = 390\Omega$
	V_{OR}	380	540	710	mVrms	$V_{DD} = 5.0V$ Row Tone, $R_L = 390\Omega$
	V_{OR}	380	550	735	mVrms	$V_{DD} = 10.0V$ Row Tone, $R_L = 240\Omega$
Ratio of Column to Row Tone	dB_{CR}	1.0	2.0	3.0	dB	$V_{DD} = 3.5 \sim 10.0V$
Distortion	%DIS			7	%	$V_{DD} = 3.5 \sim 10.0V$
XMIT OUTPUT						
Output Voltage High	V_{OH}	1.5	1.8		V	$V_{DD} = 3.0V$ $I_{OH} = 15mA$, No Key Depressed
	V_{OH}	8.5	8.8		V	$V_{DD} = 10.0V$ $I_{OH} = 50mA$, No Key Depressed
Output Source Leakage Current	I_{OF}			100	μA	$V_{DD} = 10.0V$ $V_{OF} = 0V$

9325812 UNITED MICROELECTRONICS

92D 00429

DT-75-07-07

UM9559E/F
Electrical Characteristics (Continued)

Parameter	Symbol	Min.	Typ.	Max.	Units	Conditions
MUTE OUTPUT						
Output Voltage Low	V_{OL}		0	0.5	V	$V_{DD} = 2.75V$ No Key Depressed, No Load
	V_{OL}		0	0.5	V	$V_{DD} = 10.0V$ No Key Depressed, No Load
Output Voltage High	V_{OH}	2.5	2.75		V	$V_{DD} = 2.75V$ One Key Depressed, No Load
	V_{OH}	9.5	10.0		V	$V_{DD} = 10.0V$ One Key Depressed, No Load
Output Sink Current	I_{OL}	0.53	1.3		mA	$V_{DD} = 3.0V$ $V_{OL} = 0.5V$
	I_{OL}	2.0	5.3		mA	$V_{DD} = 10.0V$ $V_{OL} = 0.5V$
Output Source Current	I_{OH}	0.17	0.41		mA	$V_{DD} = 3.0V$ $V_{OH} = 2.5V$
	I_{OH}	0.57	1.5		mA	$V_{DD} = 10.0V$ $V_{OH} = 9.5V$
OSCILLATOR INPUT/OUTPUT						
Output Sink Current	I_{OL}	0.21	0.52		mA	$V_{DD} = 3.0V$ $V_{OL} = 0.5V$, One Key Selected
	I_{OL}	0.80	2.1		mA	$V_{DD} = 10.0V$ $V_{OL} = 0.5V$, One Key Selected
Output Source Current	I_{OH}	0.13	0.31		mA	$V_{DD} = 3.0V$ $V_{OH} = 2.5V$, One Key Selected
	I_{OH}	0.42	1.1		mA	$V_{DD} = 10.0V$ $V_{OH} = 9.5V$, One Key Selected
Oscillator Startup Time	t_{START}		2	5	ms	$V_{DD} = 3.5V$
	t_{START}		0.25	4	ms	$V_{DD} = 10.0V$
Input/Output Capacitance	$C_{I/O}$		12	16	pF	$V_{DD} = 3.5V$
	$C_{I/O}$		10	14	pF	$V_{DD} = 10.0V$
INPUT CURRENTS						
Row & Column Inputs Sink Current	I_{IL}		16		μA	$V_{DD} = 3.0V$ $V_{IL} = 3.0V$ (pull-down)
	I_{IL}		24		μA	$V_{DD} = 10.0V$ $V_{IL} = 10.0V$ (pull-down)
Row & Column Inputs Source Current	I_{IH}		210		μA	$V_{DD} = 3.0V$ $V_{IH} = 2.5V$ (pull-up)
	I_{IH}		740		μA	$V_{DD} = 10.0V$ $V_{IH} = 9.5V$ (pull-up)
Mode Selected Input Source Current (UM9559E)	I_{IH}	1.4	3.3		μA	$V_{DD} = 3.0V$ $V_{IH} = 0.0V$ (pull-up)
	I_{IH}	18	46		μA	$V_{DD} = 10.0V$ $V_{IH} = 3.0V$ (pull-up)
Chip Disable Input Sink Current (UM9559F)	I_{IL}	3.9	9.5		μA	$V_{DD} = 3.0V$ $V_{IL} = 3.0V$ (pull-down)
	I_{IL}	55	143		μA	$V_{DD} = 10.0V$ $V_{IL} = 10.0V$ (pull-down)



UM9559E/F

Table 1. Comparisons of Specified vs Actual Tone Frequencies Generated by UM9559E/F

Active Input	Output Frequency Hz		% Error See Note
	Specified	Actual	
R1	697	699.1	+0.30
R2	770	766.2	-0.49
R3	852	847.4	-0.54
R4	941	948.0	+0.74
C1	1,209	1,215.9	+0.57
C2	1,336	1,331.7	-0.32
C3	1,477	1,471.9	-0.35
C4	1,633	1,645.0	+0.73

Note: % Error does not include oscillator drift.

Table 2. XMIT and MUTE Output Functional Relationship

Output	'Digit' Key Released	'Digit' Key Depressed	Comment
XMIT	V _{DD}	High Impedance	Can source at least 50mA at 10V with 1.5V max. drop
MUTE	V _{SS}	V _{DD}	Can source or sink current

Design Objectives

The specifications that are important to the design of the DTMF Generator are summarized below: the dual tone

signal consists of linear addition of two voice frequency signals. One of the two signals is selected from a group of frequencies called the "Low Group" and the other is from a group of frequencies called the "High Group". The low group consists of four frequencies 697, 770, 852, 941 Hz. The high group consists of four frequencies 1209, 1336, 1477 and 1633 Hz. A keyboard arranged in a row, column format (4 rows x 3 or 4 Columns) is used for number entry. When a push button corresponding to a digit (0 thru 9) is pushed, one appropriate row (R1 through R4) and one appropriate column (C1 thru C4) is selected. The active row input selects one of the low group frequencies and the active column input selects one of the high group frequencies. In standard dual tone telephone systems, the highest high group frequency of 1633 Hz (col. 4) is not used. The frequency tolerance must be $\pm 1.0\%$. However, the UM9559E/F provides a better than .75% accuracy. The total harmonic and intermodulation distortion of the dual tone must be less than 10% as seen at the telephone terminals. The high group to low group signal amplitude ratio should be 2.0 ± 2 dB and the absolute amplitude of the low group and high group tones must be within the allowed range. These requirements apply when the telephone is used over a short loop or long loop and over the operating temperature range. The design of the UM9559E/F takes into account these considerations.

Crystal Specification

A standard television color burst crystal is specified to have much tighter tolerance than necessary for tone generation application. By relaxing the tolerance specification it is as follows:

Frequency: 3.58 MHz $\pm 0.02\%$

R_S = 100 Ω , L_M = 96mH, C_M = 0.02pF,
C_H = 5pF, C_L = 12pF

9325812 UNITED MICROELECTRONICS

92D 00431

DT-75-07-07

**UM9559E/F****Pin Descriptions****Oscillator (OSCI, OSC0)**

UM9559E/F contains an oscillator circuit with the necessary parasitic capacitances and bias resistor on chip so that it is only necessary to connect the standard 3.58MHz TV Crystal across the OSCI and OSC0 terminals to implement the oscillator function. The oscillator functions whenever a row input is activated.

Keyboard (R1, R2, R3, R4, C1, C2, C3, C4)

UM9559E/F functions as active pull-down on the row inputs and active pull-up on the column inputs when no key is depressed. When a key is pushed a high level is seen on one of the row inputs, the oscillator starts and the keyboard scan logic turns on. The active pull-up or pull-down resistors are selectively switched on and off as the keyboard scan logic determines the row and the column inputs that are selected. The advantage of the scanning technique is that a keyboard arrangement of SPST keyboard (4 rows x 3 or 4 columns) can be used. It can also interface with CMOS logic outputs directly. UM 9559E/F requires active "High" logic levels. Since the active pull-up resistors in UM9559E/F are fairly low value (500Ω type), diode can be used as shown in Fig. 1 to eliminate excessive sink current flowing into logic outputs in their "Low" state.

Tone Output (TONE)

UM9559E/F uses the Johnson counters and resistor ladder networks (See block diagram) to Synthesize the desired two frequencies in sinewaves (See Fig. 2) and then uses the adder network to add these two frequencies and then drive a bipolar NPN transistor connected as emitter follower to allow proper impedance transformation, at the same time preserving signal level.

Mode Select (MDSL)

UM9559E has a Mode Select (MDSL) input at pin 15. When

MDSL is left floating (unconnected) or connected to V_{DD} , both the Dual Tone and Single Tone modes are available. If MDSL is connected to V_{SS} , the single tone mode is disabled and no output tone is produced if an attempt for single tone is made. UM9559E/F do not have the Mode Select option

Dual Tone Mode: When one row and one column is selected (one key pressed) dual tone output consisting of an appropriate low group and high group tone is generated. If two digit keys, that are not either in the same row or in the same column, are depressed, the dual tone mode is disabled and no output is provided.

Single Tone Mode: Single tones either in the low group or the high group can be generated as follows. A low group tone can be generated by depressing two digit keys in the appropriate row. A high group tone can be generated by depressing two digit keys in the appropriate column, i.e., selecting the appropriate column input and two row inputs in that column.

Chip Disable (CD)

UM9559E has a Chip Disable (CD) input at pin 15 instead of the Mode Select input. The chip disable is active "high". When the chip disable is active, the tone output goes to V_{SS} , the row, column inputs go into high impedance state, the Oscillator is inhibited and the Mute and XMIT outputs go into active states.

Mute Outputs (MUTE)

UM9559E/F have a CMOS buffer for the Mute output. With no keys depressed, the Mute output is "low". When a key is depressed, the Mute output goes high, and when Chip Disable is "high" the Mute output is forced "low".



UM9559E/F

XMIT Output (XMIT)

UM9559E/F have a bipolar NPN transistor as the XMIT output. With no keys depressed, the XMIT output is in the active state so that substantial current can be sourced to a load. When a key is depressed, the XMIT output goes into a high impedance state, and when Chip Disable is "high" the XMIT output is in active state

regardless of the state of the keyboard inputs.

Power (V_{DD} , V_{SS})

These are the power supply inputs UM9559E/F are designed to operate from 2.5 to 10 Volts.

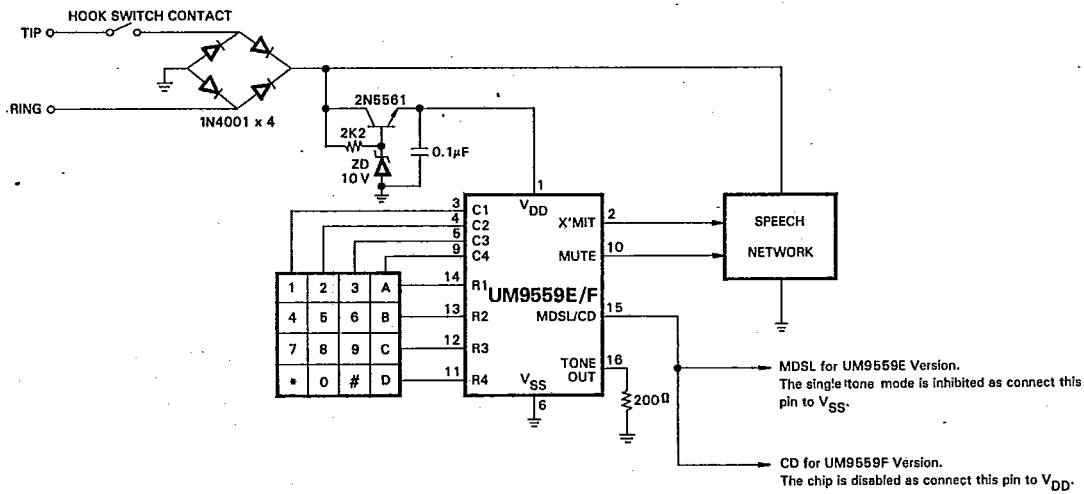

Figure 1. Tone Generator Interface Circuit

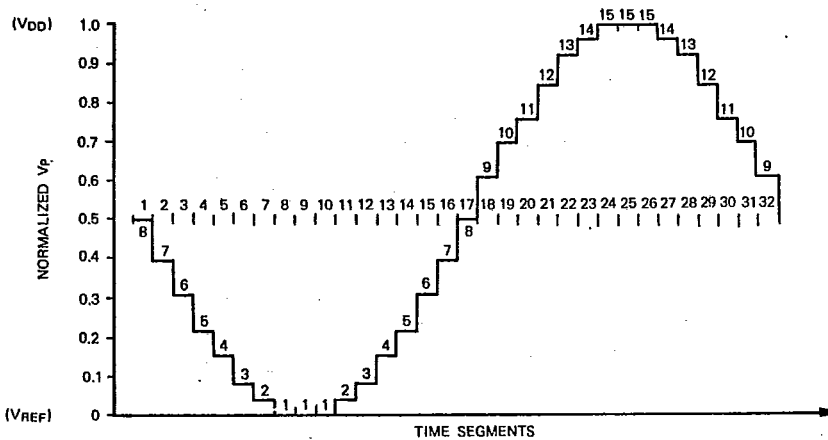

Figure 2. Stairstep Waveform of the Digitally Synthesized Sinewave

9325812 UNITED MICROELECTRONICS

92D 00433

D 7-75-07-07



UM9559E/F

UM9559E/F Tone Generator Interface Circuit

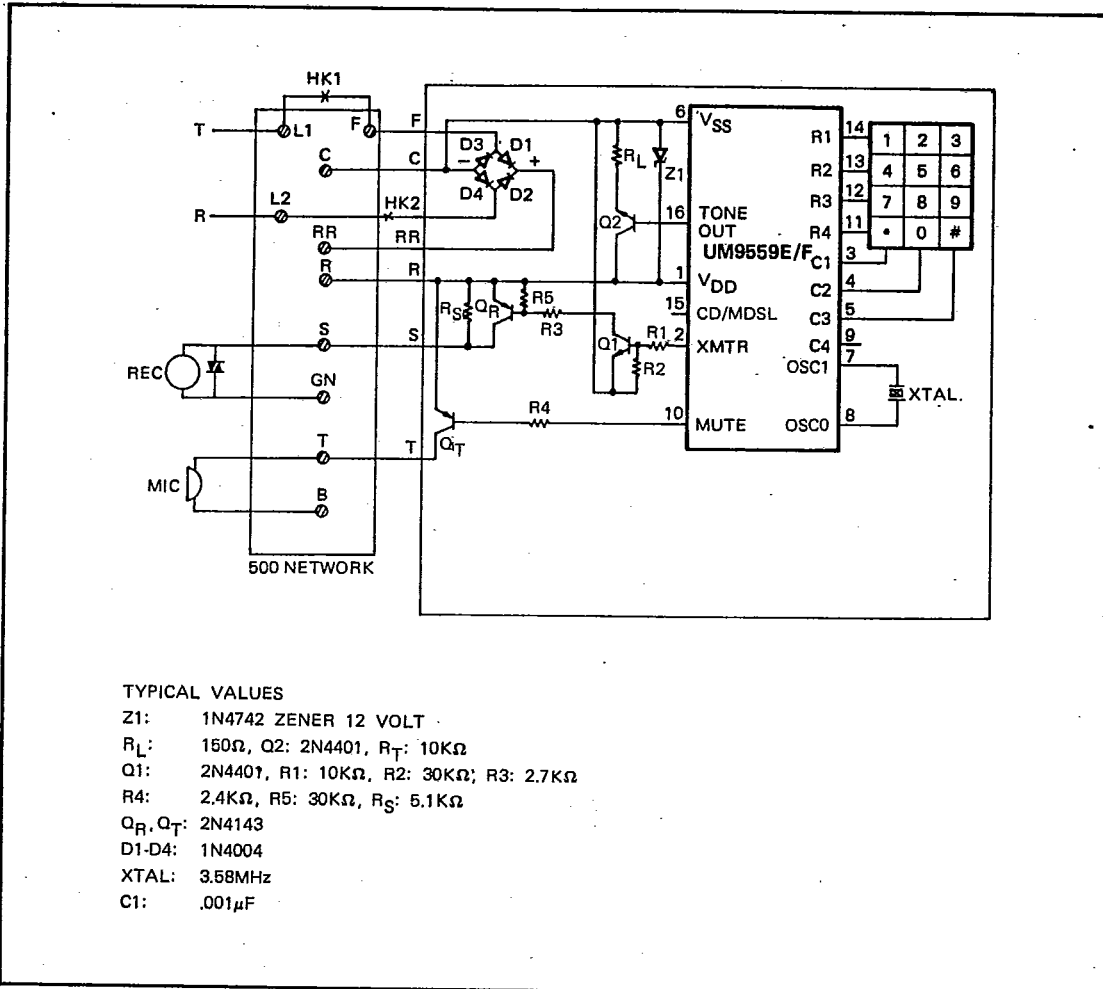

TYPICAL VALUES

- Z1: 1N4742 ZENER 12 VOLT
- R_L: 150Ω, Q2: 2N4401, R_T: 10KΩ
- Q1: 2N4401, R1: 10KΩ, R2: 30KΩ, R3: 2.7KΩ
- R4: 2.4KΩ, R5: 30KΩ, R_S: 5.1KΩ
- Q_R, Q_T: 2N4143
- D1-D4: 1N4004
- XTAL: 3.68MHz
- C1: .001μF