

AN8389S

4 Channel Linear Driver IC

■ Description

The AN8389S is a monolithic integrated circuit which employ 4 channel H-bridge system that they are suitable for driving motor or actuator of CD player. Also they employ the surface mounting type package superior in radiation characteristics.

■ Features

- Wide output D-range, regardless of the system reference voltage
- Built-in 4-channel BTL driver best suited for driving motors or actuators of 5 to 20Ω load
- Built-in thermal shutdown circuit (with Hysteresis)
- Separation between the signal and output line power supplies, allowing control of IC heating
- Reset output pin
- Shorting brake mode

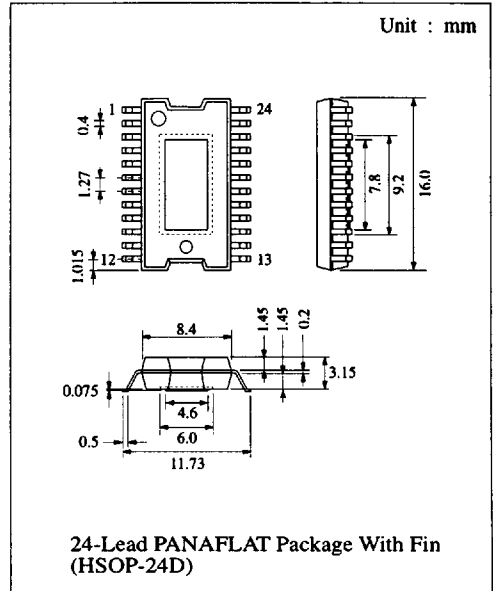

■ Block Diagram

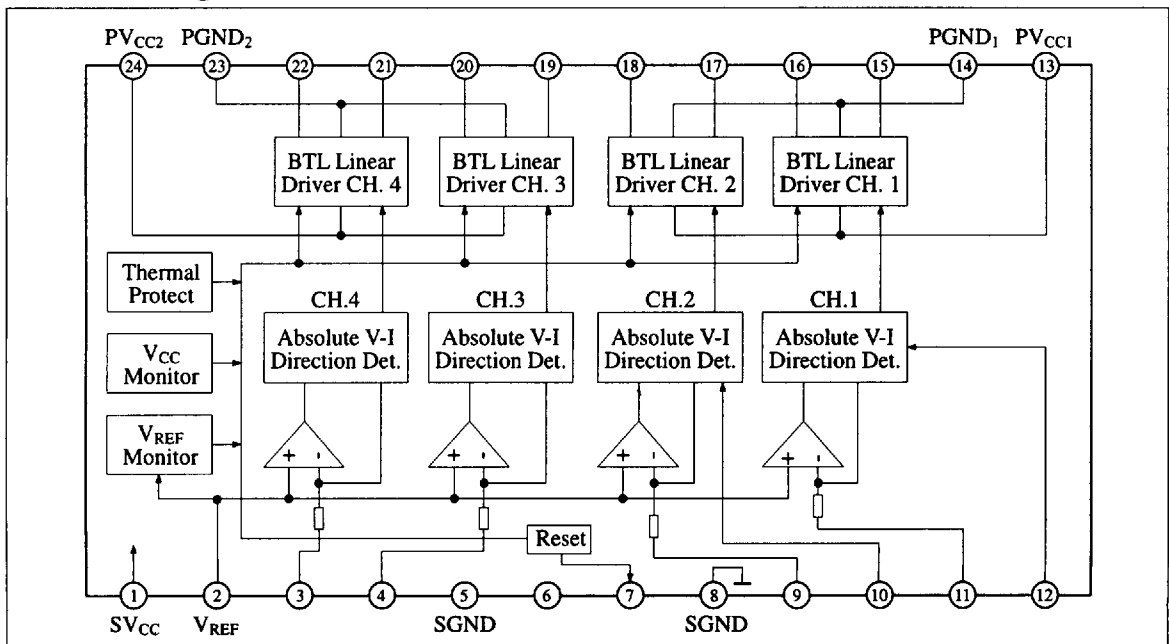

■ Absolute Maximum Ratings (Ta=25°C)

Item	Symbol	Rating	Unit
Supply Voltage	V _{CC}	20	V
Output Current	I _{out}	500	mA
Power Dissipation	P _D	1420	mW
Operating Ambient Temperature	T _{opr}	-20 ~ +75	°C
Storage Temperature	T _{stg}	-55 ~ +150	°C

Operating Supply Voltage Range: PV_{CC}, SV_{CC} = 4.7V ~ 16.0V

■ Electrical Characteristics (Ta=25°C)

Item	Symbol	Condition	min.	typ.	max.	Unit
Total Circuit Current	I _{tot}	PV _{CC1} = PV _{CC2} = SV _{CC1} = 8V	10	20	30	mA

Drivers 1 to 4

Item	Symbol	Condition	min.	typ.	max.	Unit
Input Offset Voltage	V _{IOF}	PV _{CC1} = PV _{CC2} = SV _{CC1} = 8V, R _L = 18Ω, R _{in} = 10kΩ	-7		7	mV
Output Offset Voltage	V _{OOV}		-50		50	mV
Gain (+)	G ₊		15.5	18.5	21.5	dB
(+) Relative Gain	ΔG		-1.0	0	1.0	dB
Limit Voltage (+)	VL ₊		4.95	5.3		V
Limit Voltage (-)	VL ₋			-5.3	-4.95	V
Dead Zone Width	V _{DZ}		-10		20	mV

Drivers 1 and 2, PC Operation

Item	Symbol	min.	typ.	max.	Unit
Threshold H	V _{FCH}	14			V
Threshold L	V _{PCL}			0.5	V

Reset Circuit

Item	Symbol	min.	typ.	max.	Unit
Reset Operation Release Supply Voltage	V _{RST}	4.2	4.6	4.85	V
Threshold Hysteresis Width	V _{HYS}	0.09	0.17	0.31	V
V _{REF} Detection	V _R	1.85			V

Heat Protection Circuit

Item	Symbol	min.	typ.	max.	Unit
Operation Temperature Equilibrium Value*1	T _{THD}		(150)		°C
Operation Temperature Hysteresis Width*1	ΔT _{THD}		(20)		°C

*1 : Characteristics value in parentheses is a reference value for design but not a guaranteed value.

■ Application Circuit

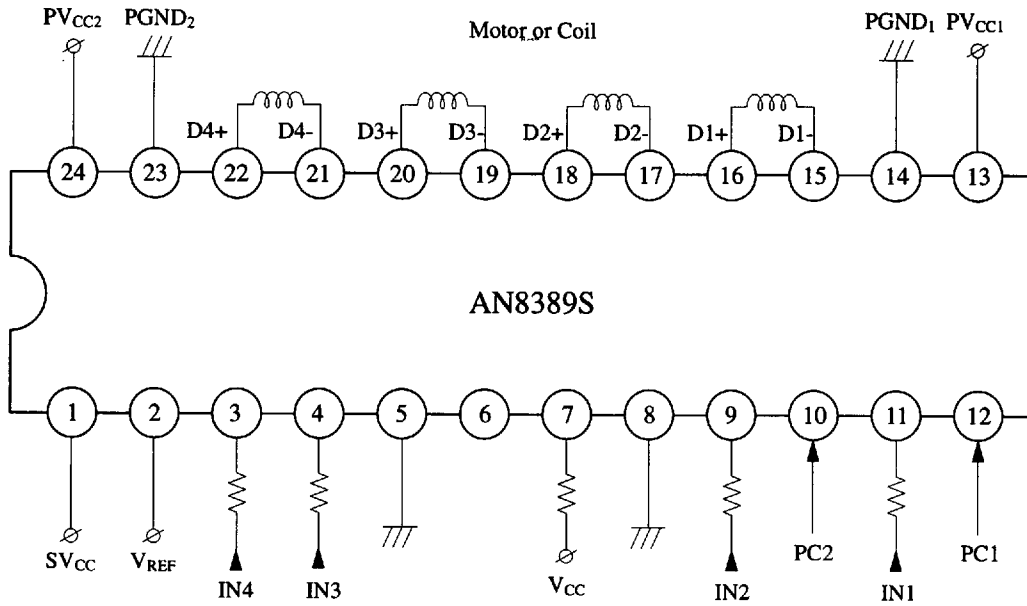

■ Pin Descriptions

Pin No.	Pin Name	I/O	DC Voltage (V _{CC} = 8V)	Equivalent Circuit	Description
1	Power Supply (SV _{CC})	I	8V		PC (power cut) input pin controlling the output of Pin 15 and Pin 16.
2	V _{REF} Input	I	2.5V		V _{REF} input pin.
3	Motor Driver 4 Input (IN4)	I	2.5V		Error input pin of Driver 4.
4	Motor Driver 3 Input (IN3)	I	2.5V		Error input pin of Driver 3.
9	Motor Driver 2 Input (IN2)	I	2.5V		Error input pin of Driver 2.
11	Motor Driver 1 Input (IN1)	I	2.5V		Error input pin of Driver 1.
5 8	GND	I	0V		GND pin for control circuit of driver.
6	No Connection (NC)				
7	Reset Output (NRESET)	O			Reset output pin.

■ Pin Descriptions

Pin No.	Pin Name	I/O	DC Voltage (V _{CC} = 8V)	Equivalent Circuit	Description
10	Power Cut Input 2 (PC2)	I	0V		PC (power cut) input pin controlling the output of Pin 15 and Pin 16.
12	Power Cut Input 2 (PC1)	I	0V		PC (power cut) input pin controlling the output of Pin 17 and Pin 18.
13	Power Supply 1 for Driver (PVCC1)	I	8V		Power V _{CC} pin, supplying the current flowing for output power transistors of Pin 15, 16, 17 and 18.
24	Power Supply 2 for Driver (PVCC2)	I	8V		Power V _{CC} pin, supplying the current flowing for output power transistors of Pin 19, 20, 21 and 22.
14	GND 1 for Driver	I	0V		GND pin for output power transistors of Pin 15, 16, 17 and 18.
23	GND 1 for Driver	I	0V		GND pin for output power transistors of Pin 15, 16, 17 and 18.
15	Motor Driver 1 Reverse Output (D1-)	O	0V		Reverse rotation output pin of Driver 1.
16	Motor Driver 1 Forward Output (D1+)	O	0V		Normal rotation output pin of Driver 1.
17	Motor Driver 2 Reverse Output (D2-)	O	0V		Reverse rotation output pin of Driver 2.
18	Motor Driver 2 Forward Output (D2+)	O	0V		Normal rotation output pin of Driver 2.
19	Motor Driver 1 Reverse Output (D3-)	O	0V		Reverse rotation output pin of Driver 3.
20	Motor Driver 1 Forward Output (D3+)	O	0V		Normal rotation output pin of Driver 3.
21	Motor Driver 2 Reverse Output (D4-)	O	0V		Reverse rotation output pin of Driver 4.
22	Motor Driver 2 Forward Output (D4+)	O	0V		Normal rotation output pin of Driver 4.

■ Supplementary Explanation

● Cautions for use

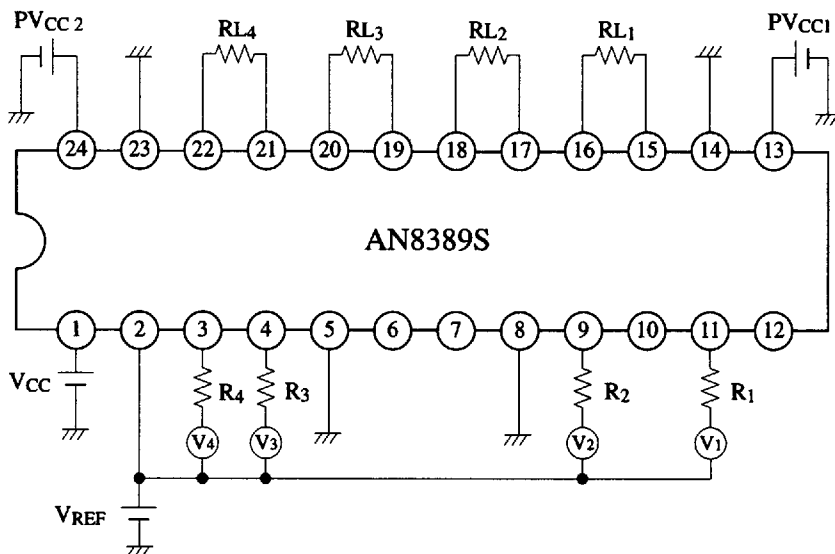

When using AN8389S, refer to the following notes and follow the power dissipation characteristics curve.

- (1) The load current, I_{P1} , passing through loads $RL1$ and $RL2$ is supplied through pin No.13.

$$I_{P1} = I_{V16-15}/RL1 + I_{V18-17}/RL2$$

- (2) The load current, I_{P2} , passing through loads $RL3$ and $RL4$ is supplied through pin No.24.

$$I_{P2} = I_{V20-19}/RL3 + I_{V22-21}/RL4$$

- (3) The dissipation increment, ΔP_D , in the IC (power output step) through loads $RL1$, $RL2$, $RL3$ and $RL4$ is as follows.

$$\begin{aligned} \Delta P_D = & (PVCC1 - I_{V16-15}) \times I_{V16-15}/RL1 \\ & + (PVCC1 - I_{V18-17}) \times I_{V18-17}/RL2 \\ & + (PVCC2 - I_{V20-19}) \times I_{V20-19}/RL3 \\ & + (PVCC2 - I_{V22-21}) \times I_{V22-21}/RL4 \end{aligned}$$

- (4) The dissipation increment, ΔP_S , in the IC (signal block, supplied from pin No.1) through loads $RL1$, $RL2$, $RL3$, and $RL4$ is approximately as follows.

$$\begin{aligned} I_T = & I_{V1}/R1 + I_{V2}/R2 + I_{V3}/R3 + I_{V4}/R4 \\ \Delta P_S = & V_{CC} \times I_T \times 10 + V_{CC} \times (I_{P1} + I_{P2}) \times 10^{-2} \end{aligned}$$

- (5) The dissipation increment of the IC, when the driver operates, is $\Delta P_D + \Delta P_S$.