

# TABLE OF CONTENTS

<b>1</b>	<b>GENERAL DESCRIPTION.....</b>	<b>1</b>
<b>2</b>	<b>FEATURES .....</b>	<b>2</b>
2.1	Integrated Display Buffer .....	2
2.2	CPU Interface.....	2
2.3	Display Support.....	2
2.4	Display Modes.....	2
2.5	Display Features .....	2
2.6	Clock Source .....	3
2.7	Miscellaneous.....	3
2.8	Package.....	3
<b>3</b>	<b>ORDERING INFORMATION.....</b>	<b>3</b>
<b>4</b>	<b>BLOCK DIAGRAM .....</b>	<b>4</b>
4.1	PIN ARRANGEMENT.....	5
4.1.1	100 pin TQFP .....	5
4.1.2	100 pin TFBGA .....	7
<b>5</b>	<b>PIN DESCRIPTION .....</b>	<b>9</b>
5.1	Host Interface .....	10
5.2	LCD Interface.....	12
5.3	Clock Input.....	13
5.4	Miscellaneous.....	13
5.5	Power and Ground.....	13
5.6	Summary of Configuration Options.....	14
5.7	Host Bus Interface Pin Mapping.....	15
5.8	LCD Interface Pin Mapping .....	16
5.9	Data Bus Organization .....	17

<b>6</b>	<b>FUNCTIONAL BLOCK DESCRIPTIONS .....</b>	<b>18</b>
6.1	MCU Interface .....	18
6.2	Control Register .....	18
6.3	Display Output.....	18
6.4	Display Buffer.....	18
6.5	PWM Clock and CV Pulse Control.....	18
6.6	Clock Generator .....	18
<b>7</b>	<b>REGISTERS .....</b>	<b>19</b>
7.1	Register Mapping .....	19
7.2	Register Descriptions .....	19
7.2.1	Read-Only Configuration Registers.....	19
7.2.2	Clock Configuration Registers .....	20
7.2.3	Look-Up Table Registers .....	21
7.2.4	Panel Configuration Registers .....	25
7.2.5	Display Mode Registers .....	36
7.2.6	Main Window Registers .....	39
7.2.7	Floating Window Registers.....	41
7.2.8	Miscellaneous Registers .....	46
7.2.9	General IO Pins Registers.....	48
7.2.10	Pulse Width Modulation (PWM) Clock and Contrast Voltage (CV) Pulse Configuration Registers .....	51
7.2.11	Cursor Mode Registers .....	54
<b>8</b>	<b>MAXIMUM RATINGS .....</b>	<b>65</b>
<b>9</b>	<b>DC CHARACTERISTICS .....</b>	<b>66</b>
<b>10</b>	<b>AC CHARACTERISTICS .....</b>	<b>66</b>
10.1	Clock Timing.....	67
10.1.1	Input Clocks .....	67
10.1.2	Internal Clocks .....	68
10.2	CPU Interface Timing.....	69
10.2.1	Generic #1 Interface Timing.....	69
10.2.2	Generic #2 Interface Timing (e.g. ISA).....	71

10.2.3	Motorola MC68K #1 Interface Timing (e.g. MC68000) .....	73
10.2.4	Motorola DragonBall Interface Timing with DTACK# (e.g. MC68EZ328/MC68VZ328) 75	
10.2.5	Motorola DragonBall Interface Timing without DTACK# (e.g. MC68EZ328/MC68VZ328) .....	77
10.2.6	Hitachi SH-3 Interface Timing (e.g. SH7709A) .....	79
10.2.7	Hitachi SH-4 Interface Timing (e.g. SH7751) .....	81
10.3	LCD Power Sequencing .....	83
10.3.1	Passive/TFT Power-On Sequence.....	83
10.3.2	Passive/TFT Power-Off Sequence.....	84
10.3.3	Power Saving Status .....	85
10.4	Display Interface .....	86
10.4.1	Generic STN Panel Timing.....	87
10.4.2	Monochrome 4-Bit Panel Timing.....	89
10.4.3	Monochrome 8-Bit Panel Timing.....	92
10.4.4	Color 4-Bit Panel Timing .....	95
10.4.5	Color 8-Bit Panel Timing (Format stripe) .....	98
10.4.6	Generic TFT Panel Timing .....	101
10.4.7	9/12/18-Bit TFT Panel Timing.....	102
10.4.8	160x160 Sharp HR-TFT Panel Timing (e.g. LQ031B1DDxx) .....	106
10.4.9	Generic HR-TFT Panel Timing .....	110
11	CLOCKS.....	112
11.1	Clock Descriptions .....	112
11.1.1	BCLK .....	112
11.1.2	MCLK.....	113
11.1.3	PCLK .....	113
11.1.4	PWMCLK.....	114
11.2	Clocks versus Functions .....	115
12	POWER SAVING MODE.....	116
13	FRAME RATE CALCULATION .....	116
14	DISPLAY DATA FORMATS .....	117
15	LOOK-UP TABLE ARCHITECTURE.....	118

15.1	Monochrome Modes .....	118
15.1.1	1 Bit-per-pixel Monochrome Mode.....	118
15.1.2	2 Bit-per-pixel Monochrome Mode.....	118
15.1.3	4 Bit-per-pixel Monochrome Mode.....	119
15.1.4	8 Bit-per-pixel Monochrome Mode.....	119
15.1.5	16 Bit-Per-Pixel Monochrome Mode .....	119
15.2	Color Modes .....	120
15.2.1	1 Bit-Per-Pixel Color .....	120
15.2.2	2 Bit-Per-Pixel Color .....	121
15.2.3	4 Bit-Per-Pixel Color .....	122
15.2.4	8 Bit-per-pixel Color Mode .....	123
15.2.5	16 Bit-Per-Pixel Color Mode.....	124
16	BIG-ENDIAN BUS INTERFACE .....	124
16.1	Byte Swapping Bus Data.....	124
16.1.1	16 Bpp Color Depth .....	125
16.1.2	1/2/4/8 Bpp Color Depth .....	125
17	VIRTUAL DISPLAY MODE.....	126
18	DISPLAY ROTATE MODE.....	127
18.1	90° Display Rotate Mode .....	127
18.1.1	Register Programming .....	127
18.2	180° Display Rotate Mode .....	128
18.2.1	Register Programming .....	128
18.3	270° Display Rotate Mode .....	129
18.3.1	Register Programming .....	129
19	FLOATING WINDOW MODE.....	130
19.1	With Display Rotate Mode Enabled.....	131
19.1.1	Display Rotate Mode 90° .....	131
19.1.2	Display Rotate Mode 180° .....	131
19.1.3	Display Rotate Mode 270° .....	132
20	HARDWARE CURSOR MODE.....	133
20.1	With Display Rotate Mode Enabled.....	134
20.1.1	Display Rotate Mode 90° .....	134

20.1.2	Display Rotate Mode 180° .....	135
20.1.3	Display Rotate Mode 270° .....	135
20.2	Pixel format (Normal orientation mode) .....	135
20.2.1	4/8/16 Bit-per-pixel .....	136
20.3	Pixel format (90° Display Rotate Mode) .....	136
20.3.1	4 Bit-per-pixel .....	136
20.3.2	8 Bit-per-pixel .....	137
20.3.3	16 Bit-per-pixel .....	137
20.4	Pixel format (180° Display Rotate Mode) .....	138
20.4.1	4 Bit-per-pixel .....	138
20.4.2	8 Bit-per-pixel .....	138
20.4.3	16 Bit-per-pixel .....	139
20.5	Pixel format (270° Display Rotate Mode) .....	139
20.5.1	4 Bit-per-pixel .....	139
20.5.2	8 Bit-per-pixel .....	140
20.5.3	16 Bit-per-pixel .....	140
21	APPLICATION EXAMPLES .....	142
22	APPENDIX .....	148
22.1	Package Mechanical Drawing for 100 pins TQFP .....	148
22.2	Package Mechanical Drawing for 100 pins TFBGA .....	149
22.3	Register Table .....	151

## List of Figures

Figure 4-1 : Block Diagram .....	4
Figure 4-2 : Pinout Diagram – 100 pin TQFP .....	5
Figure 4-3 : Pinout Diagram – 100 pin TFBGA .....	7
Figure 7-1 : GPIO Offset for 320x240 HR-TFT .....	35
Figure 7-2 : Display Data Byte/Word Swap .....	38
Figure 7-3 : PWM Clock/CV Pulse Block Diagram .....	51
Figure 10-1 : Clock Input Requirements .....	67
Figure 10-2 : Generic #1 Interface Timing .....	69
Figure 10-3 : Generic #2 Interface Timing .....	71
Figure 10-4 : Motorola MC68K #1 Interface Timing.....	73
Figure 10-5 : Motorola DragonBall Interface with DTACK# Timing .....	75
Figure 10-6 : Motorola DragonBall Interface without DTACK# Timing .....	77
Figure 10-7 : Hitachi SH-3 Interface Timing.....	79
Figure 10-8 : Hitachi SH-4 Interface Timing.....	81
Figure 10-9 : Passive/TFT Power-On Sequence Timing .....	83
Figure 10-10 : Passive/TFT Power-Off Sequence Timing .....	84
Figure 10-11 : Power Saving Status Timing .....	85
Figure 10-12 : Panel Timing Parameters.....	86
Figure 10-13 : Generic STN Panel Timing .....	87
Figure 10-14 : Monochrome 4-Bit Panel Timing .....	89
Figure 10-15 : Monochrome 4-Bit Panel A.C. Timing .....	90
Figure 10-16 : Monochrome 8-Bit Panel Timing .....	92
Figure 10-17 : Monochrome 8-Bit Panel A.C. Timing .....	93
Figure 10-18 : Color 4-Bit Panel Timing.....	95
Figure 10-19 : Color 4-Bit Panel A.C. Timing.....	96
Figure 10-20 : Color 8-Bit Panel Timing (Format stripe) .....	98
Figure 10-21 : Color 8-Bit Panel A.C. Timing (Format stripe).....	99
Figure 10-22 : Generic TFT Panel Timing .....	101
Figure 10-23 : 12-Bit TFT Panel Timing.....	102
Figure 10-24 : TFT A.C. Timing.....	104
Figure 10-25 : 160x160 Sharp HR-TFT Panel Horizontal Timing.....	106
Figure 10-26 : 160x160 Sharp HR-TFT Panel Vertical Timing.....	108
Figure 10-27 : HR-TFT Panel Horizontal Timing.....	110
Figure 10-28 : HR-TFT Panel Vertical Timing.....	111
Figure 11-1 : Clock Generator Block Diagram.....	112
Figure 14-1 : 1/2/4/8/16 Bit-Per-Pixel Display Data Memory Organization .....	117
Figure 15-1 : 1 Bit-per-pixel Monochrome Mode Data Output Path .....	118
Figure 15-2 : 2 Bit-per-pixel Monochrome Mode Data Output Path .....	118
Figure 15-3 : 4 Bit-per-pixel Monochrome Mode Data Output Path .....	119
Figure 15-4 : 8 Bit-per-pixel Monochrome Mode Data Output Path .....	119
Figure 15-5 : 1 Bit-Per-Pixel Color Mode Data Output Path.....	120
Figure 15-6 : 2 Bit-Per-Pixel Color Mode Data Output Path.....	121
Figure 15-7 : 4 Bit-Per-Pixel Color Mode Data Output Path.....	122
Figure 15-8 : 8 Bit-per-pixel Color Mode Data Output Path.....	123
Figure 16-1 : Byte-swapping for 16 Bpp .....	124
Figure 16-2 : Byte-swapping for 1/2/4/8 Bpp .....	125
Figure 17-1 : Main Window inside Virtual Image Area.....	126
Figure 18-1 : Relationship Between The Screen Image and the Image Refreshed in 90° Display Rotate Mode.....	127
Figure 18-2 : Relationship Between The Screen Image and the Image Refreshed in 180° Display Rotate Mode.....	128

Figure 18-3 : Relationship Between The Screen Image and the Image Refreshed in 270° Display Rotate Mode.....	129
Figure 19-1 : Floating Window with Display Rotate Mode disabled .....	130
Figure 19-2 : Floating Window with Display Rotate Mode 90° enabled.....	131
Figure 19-3 : Floating Window with Display Rotate Mode 180° enabled .....	131
Figure 19-4 : Floating Window with Display Rotate Mode 270° enabled .....	132
Figure 20-1 : Display Precedence in Hardware Cursor .....	133
Figure 20-2 : Cursors on the main window .....	134
Figure 20-3 : Cursors with Display Rotate Mode 90° enabled.....	134
Figure 20-4 : Cursors with Display Rotate Mode 180° enabled.....	135
Figure 20-5 : Cursors with Display Rotate Mode 270° enabled.....	135
Figure 21-1: Typical System Diagram (Generic #1 Bus) .....	142
Figure 21-2 : Typical System Diagram (Generic #2 Bus) .....	143
Figure 21-3 : Typical System Diagram (MC68K # 1, Motorola 16-Bit 68000) .....	144
Figure 21-4 : Typical System Diagram (Motorola MC68EZ328/MC68VZ328 “DragonBall” Bus).....	145
Figure 21-5 : Typical System Diagram (Hitachi SH-3 Bus).....	146
Figure 21-6 : Typical System Diagram (Hitachi SH-4 Bus).....	147

## List of Tables

Table 3-1 : Ordering Information .....	3
Table 4-1 : TQFP Pin Assignment Table .....	6
Table 4-2 : TFBGA Pin Assignment Table .....	8
Table 5-1 : Host Interface Pin Descriptions .....	10
Table 5-2 : LCD Interface Pin Descriptions.....	12
Table 5-3 : Clock Input Pin Descriptions.....	13
Table 5-4 : Miscellaneous Pin Descriptions .....	13
Table 5-5 : Power And Ground Pin Descriptions .....	13
Table 5-6 : Summary of Power-On/Reset Options .....	14
Table 5-7 : Host Bus Interface Pin Mapping .....	15
Table 5-8 : LCD Interface Pin Mapping.....	16
Table 5-9 : Data Bus Organization.....	17
Table 5-10 : Pin State Summary.....	17
Table 7-1 : MCLK Divide Selection .....	20
Table 7-2 : PCLK Divide Selection.....	21
Table 7-3 : PCLK Source Selection .....	21
Table 7-4 : Panel Data Width Selection .....	25
Table 7-5 : Active Panel Resolution Selection .....	26
Table 7-6 : LCD Panel Type Selection.....	26
Table 7-7 : Color Invert Mode Options.....	37
Table 7-8 : LCD Bit-per-pixel Selection .....	37
Table 7-9 : Display Rotate Mode Select Options.....	39
Table 7-10 : 32-bit Address X Increments for Various Color Depths.....	43
Table 7-11 : 32-bit Address Y Increments for Various Color Depths.....	44
Table 7-12 : 32-bit Address X Increments for Various Color Depths.....	45
Table 7-13 : 32-bit Address Y Increments for Various Color Depths.....	46
Table 7-14 : PWM Clock Control.....	51
Table 7-15 : CV Pulse Control .....	52
Table 7-16 : PWM Clock Divide Select Options.....	52
Table 7-17 : CV Pulse Divide Select Options .....	53
Table 7-18 : LPWMOUT Duty Cycle Select Options.....	54
Table 7-19 : X Increment Mode for Various Color Depths.....	57
Table 7-20 : Y Increment Mode for Various Color Depths.....	58
Table 8-1 : Absolute Maximum Ratings .....	65
Table 8-2 : Recommended Operating Conditions .....	66
Table 9-1 : Electrical Characteristics for IOV <sub>DD</sub> = 3.3V typical.....	66
Table 10-1 : Clock Input Requirements for CLK1 .....	67
Table 10-2 : Clock Input Requirements for AUXCLK.....	68
Table 10-3 : Internal Clock Requirements .....	68
Table 10-4 : Generic #1 Interface Timing .....	70
Table 10-5 : Generic #2 Interface Timing .....	72
Table 10-6 : Motorola MC68K #1 Interface Timing.....	74
Table 10-7 : Motorola DragonBall Interface with DTACK# Timing .....	76
Table 10-8 : Motorola DragonBall Interface without DTACK# Timing .....	78
Table 10-9 : Hitachi SH-3 Interface Timing.....	80
Table 10-10 : Hitachi SH-4 Interface Timing.....	82
Table 10-11 : Passive/TFT Power-On Sequence Timing .....	83
Table 10-12 : Passive/TFT Power-Off Sequence Timing .....	84
Table 10-13 : Power Saving Status Timing.....	85
Table 10-14 : Panel Timing Parameter Definition and Register Summary.....	86
Table 10-15 : Monochrome 4-Bit Panel A.C. Timing .....	91
Table 10-16 : Monochrome 8-Bit Panel A.C. Timing .....	94
Table 10-17 : Color 4-Bit Panel A.C. Timing.....	97



Table 10-18 : Color 8-Bit Panel A.C. Timing (Format stripe).....	100
Table 10-19 : TFT A.C. Timing.....	105
Table 10-20 : 160x160 Sharp HR-TFT Horizontal Timing .....	107
Table 10-21 : 160x160 Sharp HR-TFT Panel Vertical Timing .....	109
Table 10-22 : 320x240 HR-TFT Panel Horizontal Timing.....	111
Table 10-23 : 320x240 HR-TFT Panel Vertical Timing.....	111
Table 11-1 : BCLK Clock Selection.....	112
Table 11-2 : MCLK Clock Selection .....	113
Table 11-3 : PCLK Clock Selection.....	114
Table 11-4 : Relationship between MCLK and PCLK.....	114
Table 11-5 : PWMCLK Clock Selection .....	115
Table 11-6 : SSD1906 Internal Clock Requirements .....	115
Table 12-1 : Power Saving Mode Function Summary .....	116
Table 20-1 : Indexing scheme for Hardware Cursor.....	133
Table 22-1 : SSD1906 Register Table (1 of 3).....	151
Table 22-2 : SSD1906 Register Table (2 of 3).....	152
Table 22-3 : SSD1906 Register Table (3 of 3).....	153



# SSD1906

## ***Advance Information***

### **LCD Graphics Controller CMOS**

#### **1 GENERAL DESCRIPTION**

The SSD1906 is a graphics controller with built-in 256Kbyte SRAM display buffer, supporting color and mono LCD. The SSD1906 can support a wide range of active and passive panels, and interface with various CPUs. The advanced design, together with integration of memory and timing circuits make a low cost, low power, single chip solution to meet the handheld devices or appliances market needs, such as Pocket/Palm-size PCs and mobile communication devices.

The SSD1906 supports most of the resolutions commonly used in portable applications, and is featured with hardware display rotation, covering different form factor needs. The controller also features Virtual Display, Floating Window (variable size Overlay Window) and two Cursors to reduce the software manipulation. The 32-bit internal data path provides high bandwidth display memory for fast screen updates. The SSD1906 also provides the advantage of a single power supply.

The SSD1906 features low-latency CPU access, which supports microprocessors without READY/WAIT# handshaking signals. This controller impartiality to CPU type or operating system makes it an ideal display solution for a wide variety of applications. The SSD1906 is available in a 100 pin TQFP & TFBGA package.

This document contains information on a new product under definition stage. Solomon Systech Limited reserves the right to change or discontinue this product without notice.

<http://www.solomon-systech.com>

**SSD1906**

Rev 1.0

P 1/154

Oct 2003

Copyright © 2003 **Solomon Systech Limited**



**SOLOMON  
SYSTECH**

## 2 FEATURES

### 2.1 Integrated Display Buffer

- Embedded 256K byte SRAM display buffer.

### 2.2 CPU Interface

- Directly interfaces to :
  - Generic #1 bus interface with WAIT# signal
  - Generic #2 bus interface with WAIT# signal
  - Intel StrongARM / XScale
  - Motorola MX1 Dragonball
  - Motorola MC68K
  - Motorola DragonBall MC68EZ328/MC68VZ328
  - Hitachi SH-3
  - Hitachi SH-4
- 8-bit processor support with “glue logic”.
- “Fixed” and low-latency CPU access times.
- Registers are memory-mapped which dedicated M/R# input selects between memory and register address space.
- The contiguous 256K byte display buffer is directly accessible through the 18-bit address bus.

### 2.3 Display Support

- 4/8-bit monochrome STN interface.
- 4/8-bit color STN interface.
- 9/12/18-bit Active Matrix TFT interface.
- Direct support for 18-bit Sharp HR-TFT interface (160x160, 320x240).

### 2.4 Display Modes

- 1/2/4/8/16 bit-per-pixel (bpp) color depths.
- Up to 64 gray shades using Frame Rate Control (FRC) and dithering on monochrome passive LCD panels.
- Up to 256k colors on passive STN panels.
- Up to 256k colors on active matrix LCD panels.
- Resolution examples :
  - 320x320 at a color depth of 16 bpp
  - 160x160 at a color depth of 16 bpp
  - 160x240 at a color depth of 16 bpp

### 2.5 Display Features

- Display Rotate Mode : 90°, 180°, 270° counter-clockwise hardware rotation of display image.
- Virtual display support : displays image larger than the panel size through the use of panning and scrolling.
- Floating Window Mode : displays a variable size window overlaid on background image.
- 2 Hardware Cursors (for 4/8/16 bpp) : simultaneously displays two cursors overlaid on background image.
- Double Buffering/Multi-pages: provides smooth animation and instantaneous screen updates.

## 2.6 Clock Source

- Two clock inputs: CLKI and AUXCLK. It is possible to use one clock input only.
- Bus clock (BCLK) is derived from CLKI, can be internally divided by 2, 3, or 4.
- Memory clock (MCLK) is derived from BCLK. It can be internally divided by 2, 3, or 4.
- Pixel clock (PCLK) can be derived from CLKI, AUXCLK, BCLK, or MCLK. It can be internally divided by 2, 3, 4, or 8.

## 2.7 Miscellaneous

- Hardware/Software Color Invert
- Software Power Saving mode
- General Purpose Input / Output pins available
- Single Supply Operation : 3.0V – 3.6V

## 2.8 Package

- 100-pin TQFP package
- 100-pin TFBGA package

## 3 ORDERING INFORMATION

Table 3-1 : Ordering Information

Ordering Part Number	Package Form
SSD1906QT2	100 TQFP
SSD1906BT14	100 TFBGA

## 4 BLOCK DIAGRAM

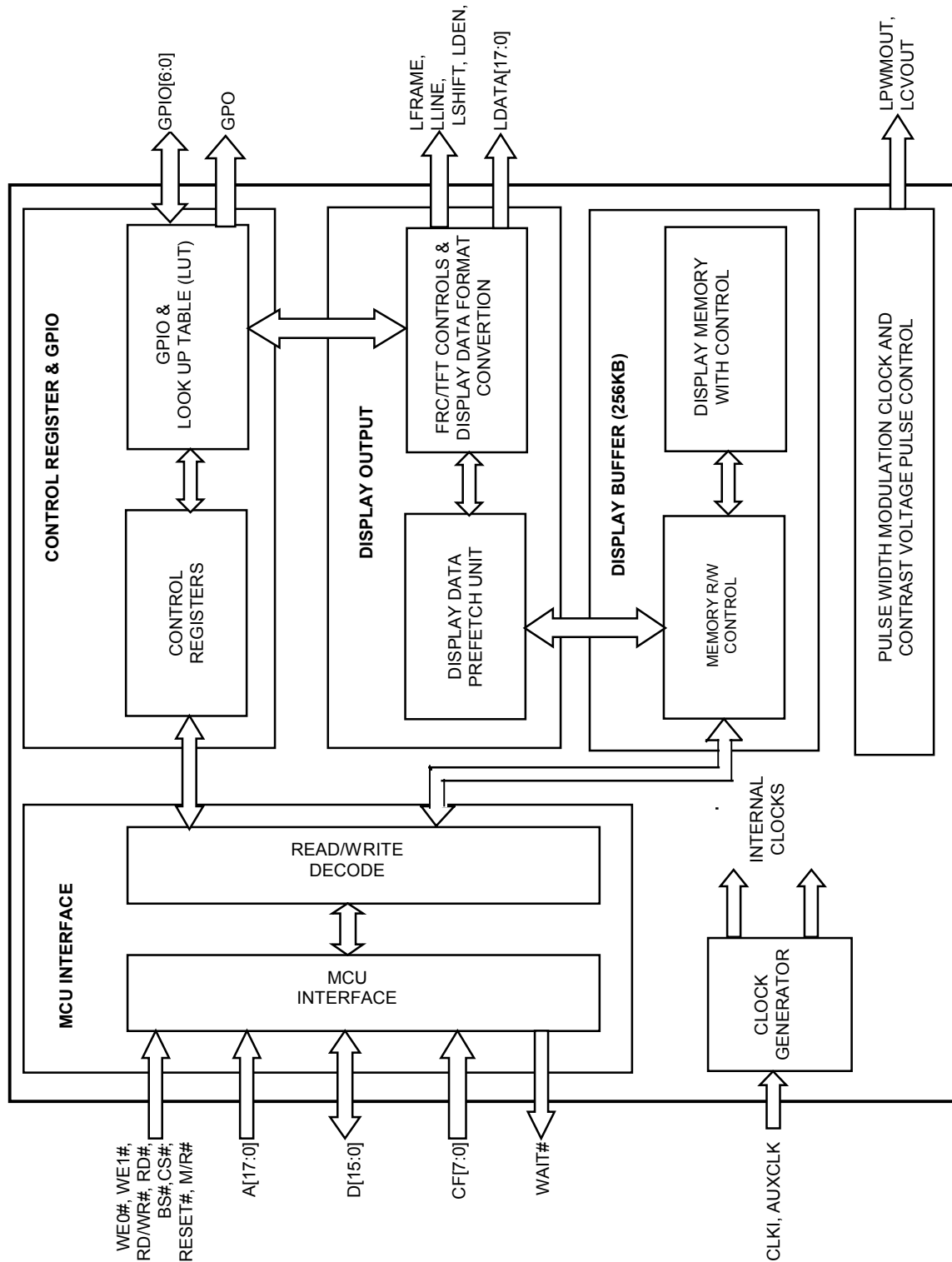

Figure 4-1 : Block Diagram

## 4.1 PIN ARRANGEMENT

### 4.1.1 100 pin TQFP

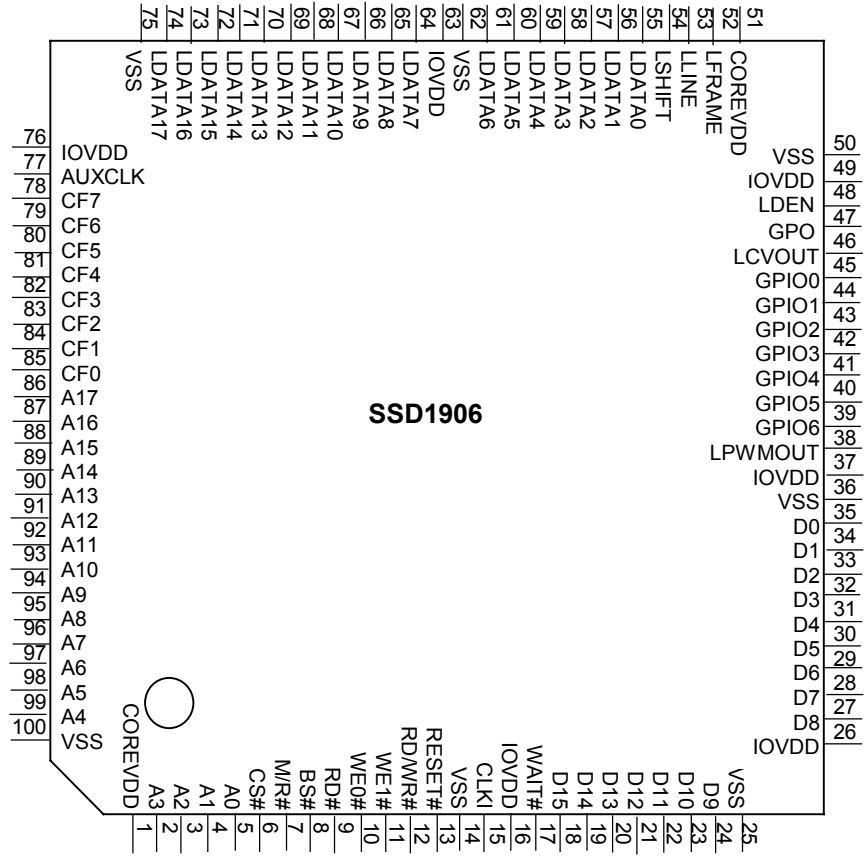

Figure 4-2 : Pinout Diagram – 100 pin TQFP

#### Note

CoreVDD is an internal regulator output pin. 0.1 $\mu$ F capacitor to V<sub>SS</sub> must be required on each CoreVDD pin.

**Table 4-1 : TQFP Pin Assignment Table**

Pin #	Signal Name	Pin #	Signal Name	Pin #	Signal Name	Pin #	Signal Name
1	COREVDD	26	IOVDD	51	COREVDD	76	IOVDD
2	A3	27	D8	52	LFRAME	77	AUXCLK
3	A2	28	D7	53	LLINE	78	CF7
4	A1	29	D6	54	LSHIFT	79	CF6
5	A0	30	D5	55	LDATA0	80	CF5
6	CS#	31	D4	56	LDATA1	81	CF4
7	M/R#	32	D3	57	LDATA2	82	CF3
8	BS#	33	D2	58	LDATA3	83	CF2
9	RD#	34	D1	59	LDATA4	84	CF1
10	WE0#	35	D0	60	LDATA5	85	CF0
11	WE1#	36	V <sub>ss</sub>	61	LDATA6	86	A17
12	RD/WR#	37	IOVDD	62	V <sub>ss</sub>	87	A16
13	RESET#	38	LPWMOUT	63	IOVDD	88	A15
14	V <sub>ss</sub>	39	GPIO6	64	LDATA7	89	A14
15	CLKI	40	GPIO5	65	LDATA8	90	A13
16	IOVDD	41	GPIO4	66	LDATA9	91	A12
17	WAIT#	42	GPIO3	67	LDATA10	92	A11
18	D15	43	GPIO2	68	LDATA11	93	A10
19	D14	44	GPIO1	69	LDATA12	94	A9
20	D13	45	GPIO0	70	LDATA13	95	A8
21	D12	46	LCVOUT	71	LDATA14	96	A7
22	D11	47	GPO	72	LDATA15	97	A6
23	D10	48	LDEN	73	LDATA16	98	A5
24	D9	49	IOVDD	74	LDATA17	99	A4
25	V <sub>ss</sub>	50	V <sub>ss</sub>	75	V <sub>ss</sub>	100	V <sub>ss</sub>



### 4.1.2 100 pin TFBGA

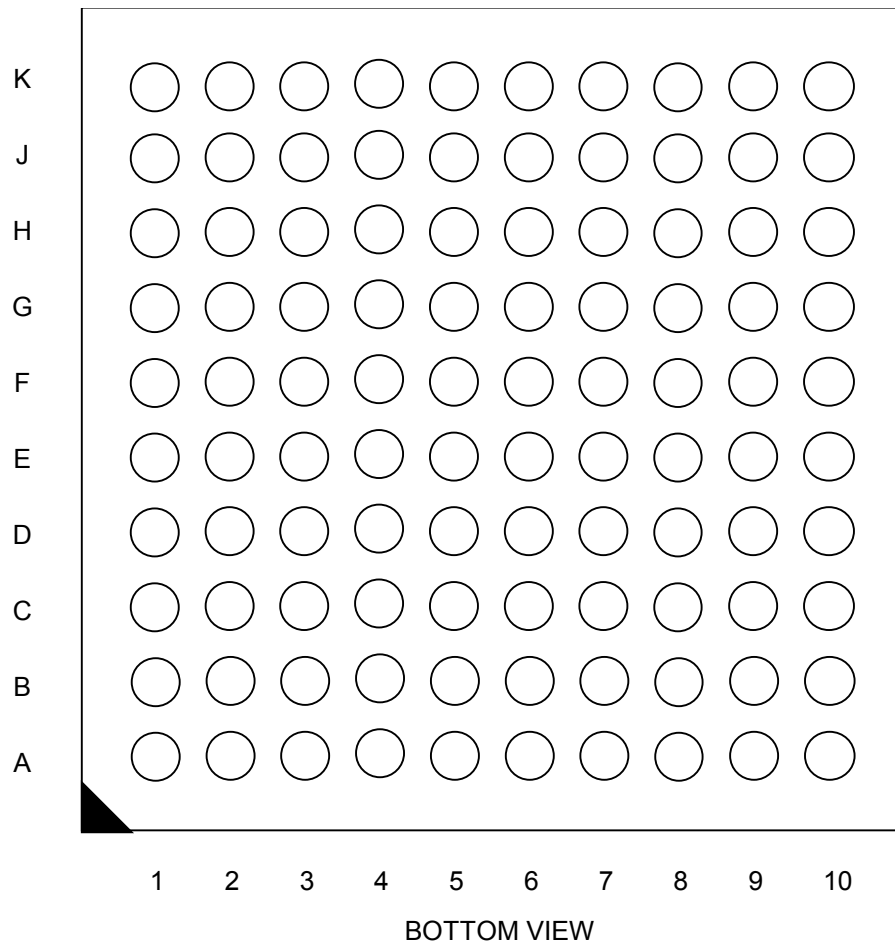

**Figure 4-3 : Pinout Diagram – 100 pin TFBGA**

**Note**

CoreVDD is an internal regulator output pin. 0.1 $\mu$ F capacitor to  $V_{SS}$  must be required on each CoreVDD pin.

**Table 4-2 : TFBGA Pin Assignment Table**

Pin #	Signal Name	Pin #	Signal Name	Pin #	Signal Name	Pin #	Signal Name	Pin #	Signal Name
A1	V <sub>SS</sub>	C1	IOVDD	E1	CF3	G1	A12	J1	A5
A2	LDATA17	C2	CF7	E2	CF2	G2	A11	J2	A4
A3	LDATA13	C3	LDATA15	E3	CF1	G3	A10	J3	A2
A4	LDATA9	C4	LDATA11	E4	CF0	G4	A9	J4	A0
A5	LDATA6	C5	IOVDD	E5	LDATA8	G5	WE0#	J5	BS#
A6	LDATA2	C6	LDATA4	E6	GPIO5	G6	RD#/WR	J6	V <sub>SS</sub>
A7	LSHIFT	C7	LDATA1	E7	GPIO6	G7	WAIT#	J7	D14
A8	LFRAME	C8	GPO	E8	LPWMOUT	G8	D4	J8	D12
A9	COREVDD	C9	LCVOUT	E9	IOVDD	G9	D5	J9	D9
A10	V <sub>SS</sub>	C10	GPIO0	E10	V <sub>SS</sub>	G10	D6	J10	IOVDD
B1	AUXCLK	D1	CF6	F1	A17	H1	A8	K1	V <sub>SS</sub>
B2	LDATA16	D2	CF5	F2	A16	H2	A7	K2	COREVDD
B3	LDATA14	D3	CF4	F3	A15	H3	A6	K3	A3
B4	LDATA10	D4	LDATA12	F4	A14	H4	CS#	K4	A1
B5	V <sub>SS</sub>	D5	LDATA7	F5	A13	H5	RD#	K5	M/R#
B6	LDATA3	D6	LDATA5	F6	WE1#	H6	RESET#	K6	CLKI
B7	LDATA0	D7	GPIO1	F7	D0	H7	IOVDD	K7	D15
B8	LLINE	D8	GPIO2	F8	D1	H8	D11	K8	D13
B9	IOVDD	D9	GPIO3	F9	D2	H9	D7	K9	D10
B10	LDEN	D10	GPIO4	F10	D3	H10	D8	K10	V <sub>SS</sub>

## 5 PIN DESCRIPTION

### Key:

I = Input  
O = Output  
IO = Bi-directional (input / output)  
P = Power pin  
LIS = LVTTTL Schmitt input  
LB2 = LVTTTL IO buffer (8mA/-8mA at 3.3V)  
LB3 = LVTTTL IO buffer (12mA/-12mA at 3.3V)  
LO3 = LVTTTL output buffer (12mA/-12mA at 3.3V)  
LT2 = Tri-state output buffer (8mA/-8mA at 3.3V)  
LT3 = Tri-state output buffer (12mA/-12mA at 3.3V)  
Hi-Z = High impedance

Note : LVTTTL is low voltage TTL (see Section 9 "DC CHARACTERISTICS").

## 5.1 Host Interface

**Table 5-1 : Host Interface Pin Descriptions**

Pin Name	Type	TQFP Pin #	TFBGA Pin #	RESET# State	Description
A0	I	5	J4	0	This input pin has multiple functions. <ul style="list-style-type: none"> <li>For Generic #1, this pin is not used and should be connected to V<sub>SS</sub>.</li> <li>For Generic #2, this is an input of system address bit 0 (A0).</li> <li>For MC68K #1, this is an input of the lower data strobe (LDS#).</li> <li>For DragonBall, this pin is not used and should be connected to V<sub>SS</sub>.</li> <li>For SH-3/SH-4, this pin is not used and should be connected to VSS.</li> </ul> See Table 5-7 : Host Bus Interface Pin Mapping for summary.
A[17:1]	I	2-4, 86-99	F1-F5, G1-G4, H1-H3, J1-J3, K3-K4	0	System address bus bits 17-1.
D[15:0]	IO	18-24, 27-35	F7-F10, G8-G10, H8-H10, J7-J9, K7-K9	Hi-Z	Input data from the system data bus. <ul style="list-style-type: none"> <li>For Generic #1, these pins are connected to D[15:0].</li> <li>For Generic #2, these pins are connected to D[15:0].</li> <li>For MC68K #1, these pins are connected to D[15:0].</li> <li>For DragonBall, these pins are connected to D[15:0].</li> <li>For SH-3/SH-4, these pins are connected to D[15:0].</li> </ul> See Table 5-7 : Host Bus Interface Pin Mapping for summary.
WE0#	I	10	G5	1	This input pin has multiple functions. <ul style="list-style-type: none"> <li>For Generic #1, this is an input of the write enable signal for the lower data byte (WE0#).</li> <li>For Generic #2, this is an input of the write enable signal (WE#).</li> <li>For MC68K #1, this pin must be tied to IOV<sub>DD</sub>.</li> <li>For DragonBall, this is an input of the byte enable signal for the D[7:0] data byte (LWE#).</li> <li>For SH-3/SH-4, this is input of the write enable signal for data D[7:0].</li> </ul> See Table 5-7 : Host Bus Interface Pin Mapping for summary.
WE1#	I	11	F6	1	This input pin has multiple functions. <ul style="list-style-type: none"> <li>For Generic #1, this is an input of the write enable signal for the upper data byte (WE1#).</li> <li>For Generic #2, this is an input of the byte enable signal for the high data byte (BHE#).</li> <li>For MC68K #1, this is an input of the upper data strobe (UDS#).</li> <li>For DragonBall, this is an input of the byte enable signal for the D[15:8] data byte (UWE#).</li> <li>For SH-3/SH-4, this is input of the write enable signal for data D[15:8].</li> </ul> See Table 5-7 : Host Bus Interface Pin Mapping for summary.
CS#	I	6	H4	1	Chip select input. See Table 5-7 : Host Bus Interface Pin Mapping for summary.
M/R#	I	7	K5	0	This input pin is used to select the display buffer or internal registers of the SSD1906. M/R# is set high to access the display buffer and low to access the registers. See Table 5-7 : Host Bus Interface Pin Mapping for summary.

Pin Name	Type	TQFP Pin #	TFBGA Pin #	RESET# State	Description
BS#	I	8	J5	1	<p>This input pin has multiple functions.</p> <ul style="list-style-type: none"> <li>For Generic #1, this pin must be tied to IOV<sub>DD</sub>.</li> <li>For Generic #2, this pin must be tied to IOV<sub>DD</sub>.</li> <li>For MC68K #1, this is an input of the address strobe (AS#).</li> <li>For DragonBall, this pin must be tied to IOV<sub>DD</sub>.</li> <li>For SH-3/SH-4, this is input of the bus start signal (BS#).</li> </ul> <p>See Table 5-7 : Host Bus Interface Pin Mapping for summary.</p>
RD/WR#	I	12	G6	1	<p>This input pin has multiple functions.</p> <ul style="list-style-type: none"> <li>For Generic #1, this is an input of the read command for the upper data byte (RD1#).</li> <li>For Generic #2, this pin must be tied to IOV<sub>DD</sub>.</li> <li>For MC68K #1, this is an input of the R/W# signal.</li> <li>For DragonBall, this pin must be tied to IOV<sub>DD</sub>.</li> <li>For SH-3/SH-4, this is input of the RD/WR# signal. The SSD1905 needs this signal for early decode of the bus cycle.</li> </ul> <p>See Table 5-7 : Host Bus Interface Pin Mapping for summary.</p>
RD#	I	9	H5	1	<p>This input pin has multiple functions.</p> <ul style="list-style-type: none"> <li>For Generic #1, this is an input of the read command for the lower data byte (RD0#).</li> <li>For Generic #2, this is an input of the read command (RD#).</li> <li>For MC68K #1, this pin must be tied to IOV<sub>DD</sub>.</li> <li>For DragonBall, this is an input of the output enable (OE#).</li> <li>For SH-3/SH-4, this is input of the read signal (RD#).</li> </ul> <p>See Table 5-7 : Host Bus Interface Pin Mapping for summary.</p>
WAIT#	O	17	G7	Hi-Z	<p>During a data transfer, this output pin is driven active to force the system to insert wait states. It is driven inactive to indicate the completion of a data transfer. WAIT# is released to the high impedance state after the data transfer is complete. Its active polarity is configurable. A pull-up or pull-down resistor should be used to resolve any data contention issues. See Table 5-6 : Summary of Power-On/Reset Options.</p> <ul style="list-style-type: none"> <li>For Generic #1, this pin outputs the wait signal (WAIT#).</li> <li>For Generic #2, this pin outputs the wait signal (WAIT#).</li> <li>For MC68K #1, this pin outputs the data transfer acknowledge signal (DTACK#).</li> <li>For DragonBall, this pin outputs the data transfer acknowledge signal (DTACK#).</li> <li>For SH-3 mode, this pin outputs the wait request signal (WAIT#).</li> <li>For SH-4 mode, this pin outputs the device ready signal (RDY#).</li> </ul> <p>See Table 5-7 : Host Bus Interface Pin Mapping for summary.</p>
RESET#	I	13	H6	0	<p>Active low input to set all internal registers to the default state and to force all signals to their inactive states. It is recommended to place a 0.1μF capacitor to V<sub>SS</sub>.</p> <p><b>Note : When reset state is released (RESET# = "H"), normal operation can be started after 3 BCLK period.</b></p>

## 5.2 LCD Interface

**Table 5-2 : LCD Interface Pin Descriptions**

Pin Name	Type	TQFP Pin #	TFBGA Pin #	Cell	RESET# State	Description
LDATA[17:0]	O	55-61, 64-74	A2-A6, B2-B4, B6-B7, C3-C4, C6-C7, D4-D6, E5	LO3	0	Panel Data bits 17-0.
LFRAME	O	52	A8	LO3	0	This output pin has multiple functions. <ul style="list-style-type: none"> <li>• Frame Pulse</li> <li>• SPS for Sharp HR-TFT</li> </ul> See Table 5-8 : LCD Interface Pin Mapping for summary.
LLINE	O	53	B8	LO3	0	This output pin has multiple functions. <ul style="list-style-type: none"> <li>• Line Pulse</li> <li>• LP for Sharp HR-TFT</li> </ul> See Table 5-8 : LCD Interface Pin Mapping for summary.
LSHIFT	O	54	A7	LO3	0	This output pin has multiple functions. <ul style="list-style-type: none"> <li>• Shift Clock</li> <li>• CLK for Sharp HR-TFT</li> </ul> See Table 5-8 : LCD Interface Pin Mapping for summary.
LDEN	O	48	B10	LO3	0	This output pin has multiple functions. <ul style="list-style-type: none"> <li>• Display enable (LDEN) for TFT panels</li> <li>• LCD backplane bias signal (MOD) for all other LCD panels</li> </ul> See Table 5-8 : LCD Interface Pin Mapping for summary.
GPIO0	IO	45	C10	LIS/ LT3	0	This pin has multiple functions. <ul style="list-style-type: none"> <li>• PS for Sharp HR-TFT</li> <li>• General purpose IO pin 0 (GPIO0)</li> <li>• Hardware Color Invert</li> </ul> See Table 5-8 : LCD Interface Pin Mapping for summary.
GPIO1	IO	44	D7	LB3	0	This pin has multiple functions. <ul style="list-style-type: none"> <li>• CLS for Sharp HR-TFT</li> <li>• General purpose IO pin 1 (GPIO1)</li> </ul> See Table 5-8 : LCD Interface Pin Mapping for summary.
GPIO2	IO	43	D8	LB3	0	This pin has multiple functions. <ul style="list-style-type: none"> <li>• REV for Sharp HR-TFT</li> <li>• General purpose IO pin 2 (GPIO2)</li> </ul> See Table 5-8 : LCD Interface Pin Mapping for summary.
GPIO3	IO	42	D9	LB3	0	This pin has multiple functions. <ul style="list-style-type: none"> <li>• SPL for Sharp HR-TFT</li> <li>• General purpose IO pin 3 (GPIO3)</li> </ul> See Table 5-8 : LCD Interface Pin Mapping for summary.
GPIO4	IO	41	D10	LB3	0	This pin has multiple functions. <ul style="list-style-type: none"> <li>• General purpose IO pin 4 (GPIO4)</li> </ul> See Table 5-8 : LCD Interface Pin Mapping for summary.
GPIO5	IO	40	E6	LB3	0	This pin has multiple functions. <ul style="list-style-type: none"> <li>• General purpose IO pin 5 (GPIO5)</li> </ul> See Table 5-8 : LCD Interface Pin Mapping for summary.
GPIO6	IO	39	E7	LB3	0	This pin has multiple functions. <ul style="list-style-type: none"> <li>• General purpose IO pin 6 (GPIO6)</li> </ul> See Table 5-8 : LCD Interface Pin Mapping for summary.
LPWMOUT	O	38	E8	LB3	0	This output pin has multiple functions. <ul style="list-style-type: none"> <li>• PWM Clock output</li> <li>• General purpose output</li> </ul>
LCVOUT	O	46	C9	LB3	0	This output pin has multiple functions.

						<ul style="list-style-type: none"> <li>• CV Pulse Output</li> <li>• General purpose output</li> </ul>
--	--	--	--	--	--	---

### 5.3 Clock Input

**Table 5-3 : Clock Input Pin Descriptions**

Pin Name	Type	TQFP Pin #	TFBGA Pin #	Cell	RESET# State	Description
CLKI	I	15	K6	LIS	—	Typically used as input clock source for bus clock and memory clock
AUXCLK	I	77	B1	LIS	—	This pin may be used as input clock source for pixel clock. This input pin must be connected to V <sub>SS</sub> if not used.

### 5.4 Miscellaneous

**Table 5-4 : Miscellaneous Pin Descriptions**

Pin Name	Type	TQFP Pin #	TFBGA Pin #	Cell	RESET # State	Description
CF[7:0]	I	78-85	C2, D1-D3, E1-E4	LIS	—	These inputs are used to configure the SSD1906 – see Table 5-6 : Summary of Power-On/Reset Options.  <b>Note: These pins are used for configuration of the SSD1906 and must be connected directly to IOV<sub>DD</sub> or V<sub>SS</sub>.</b>
GPO	O	47	C8	LO3	0	General Purpose Output (possibly used for controlling the LCD power).

### 5.5 Power and Ground

**Table 5-5 : Power And Ground Pin Descriptions**

Pin Name	Type	TQFP Pin #	TFBGA Pin #	Cell	RESET # State	Description
IOV <sub>DD</sub>	P	16, 26, 37, 49, 63, 76	B9, C1, C5, E9, H7, J10	P	—	Power supply pins. It is recommended to place a 0.1µF bypass capacitor close to each of these pins.
COREV <sub>DD</sub>	P	1, 51	A9, K2	P	—	COREV <sub>DD</sub> pins are internal voltage regulator output pins that is used by the internal circuitry only. They cannot be used for driving external circuitry. It is required to place a 0.1µF bypass capacitor close to each of these pins.
V <sub>SS</sub>	P	14, 25, 36, 50, 62, 75, 100	A1, A10, B5, E10, J6, K1, K10	P	—	Ground pins

## 5.6 Summary of Configuration Options

These pins are used for configuration of the SSD1906 and must be connected directly to IOV<sub>DD</sub> or V<sub>SS</sub>. The state of CF[5:0] is latched on the rising edge of RESET# or after the software reset function is activated (REG[A2h] bit 0). Changing state at any other time has no effect.

**Table 5-6 : Summary of Power-On/Reset Options**

SSD1906 Configuration Input	Power-On/Reset State																																					
	1 (Connected to IOV <sub>DD</sub> )	0 (Connected to V <sub>SS</sub> )																																				
CF[2:0]	Select host bus interface as follows: <table border="0"> <tr> <td>CF2</td> <td>CF1</td> <td>CF0</td> <td>Host Bus</td> </tr> <tr> <td>0</td> <td>0</td> <td>0</td> <td>SH-3/SH-4</td> </tr> <tr> <td>0</td> <td>0</td> <td>1</td> <td>MC68K #1</td> </tr> <tr> <td>0</td> <td>1</td> <td>0</td> <td>Reserved</td> </tr> <tr> <td>0</td> <td>1</td> <td>1</td> <td>Generic#1</td> </tr> <tr> <td>1</td> <td>0</td> <td>0</td> <td>Generic#2</td> </tr> <tr> <td>1</td> <td>0</td> <td>1</td> <td>Reserved</td> </tr> <tr> <td>1</td> <td>1</td> <td>0</td> <td>DragonBall (MC68EZ328/MC68VZ328)</td> </tr> <tr> <td>1</td> <td>1</td> <td>1</td> <td>Reserved</td> </tr> </table>		CF2	CF1	CF0	Host Bus	0	0	0	SH-3/SH-4	0	0	1	MC68K #1	0	1	0	Reserved	0	1	1	Generic#1	1	0	0	Generic#2	1	0	1	Reserved	1	1	0	DragonBall (MC68EZ328/MC68VZ328)	1	1	1	Reserved
CF2	CF1	CF0	Host Bus																																			
0	0	0	SH-3/SH-4																																			
0	0	1	MC68K #1																																			
0	1	0	Reserved																																			
0	1	1	Generic#1																																			
1	0	0	Generic#2																																			
1	0	1	Reserved																																			
1	1	0	DragonBall (MC68EZ328/MC68VZ328)																																			
1	1	1	Reserved																																			
	Note: The host bus interface is 17-bit only.																																					
CF3	Configure GPIO pins as inputs at power-on	Configure GPIO pins as outputs at power-on (for use by HR-TFT when selected)																																				
CF4	Big Endian bus interface	Little Endian bus interface																																				
CF5	WAIT# is active high	WAIT# is active low																																				
CF[7:6]	CLKI to BCLK divide select: <table border="0"> <tr> <td><b>CF7</b></td> <td><b>CF6</b></td> <td><b>CLKI to BCLK Divide Ratio</b></td> </tr> <tr> <td>0</td> <td>0</td> <td>1:1</td> </tr> <tr> <td>0</td> <td>1</td> <td>2:1</td> </tr> <tr> <td>1</td> <td>0</td> <td>3:1</td> </tr> <tr> <td>1</td> <td>1</td> <td>4:1</td> </tr> </table>		<b>CF7</b>	<b>CF6</b>	<b>CLKI to BCLK Divide Ratio</b>	0	0	1:1	0	1	2:1	1	0	3:1	1	1	4:1																					
<b>CF7</b>	<b>CF6</b>	<b>CLKI to BCLK Divide Ratio</b>																																				
0	0	1:1																																				
0	1	2:1																																				
1	0	3:1																																				
1	1	4:1																																				



## 5.7 Host Bus Interface Pin Mapping

**Table 5-7 : Host Bus Interface Pin Mapping**

SSD1906 Pin Name	Generic #1	Generic #2	Motorola MC68K #1	Motorola MC68EZ328/ MC68VZ328 DragonBall	Hitachi SH-3	Hitachi SH-4
A0	Connected to V <sub>SS</sub>	A0	LDS#	Connected to V <sub>SS</sub>	Connected to VSS	Connected to VSS
A[17:1]	A[17:1]	A[17:1]	A[17:1]	A[17:1]	A[17:1]	A[17:1]
D[15:0]	D[15:0]	D[15:0]	D[15:0] <sup>1</sup>	D[15:0]	D[15:0]	D[15:0]
CS#	External Decode			CSX#	CSn#	CSn#
M/R#	External Decode					
CLKI	BUSCLK	BUSCLK	CLK	CLKO	CKIO	CKIO
BS#	Connected to IOV <sub>DD</sub>		AS#	Connected to IOV <sub>DD</sub>	BS#	BS#
RD/WR#	RD1#	Connected to IOV <sub>DD</sub>	R/W#	Connected to IOV <sub>DD</sub>	RD/WR#	RD/WR#
RD#	RD0#	RD#	Connected to IOV <sub>DD</sub>	OE#	RD#	RD#
WE0#	WE0#	WE#	Connected to IOV <sub>DD</sub>	LWE#	WE0#	WE0#
WE1#	WE1#	BHE#	UDS#	UWE#	WE1#	WE1#
WAIT#	WAIT#	WAIT#	DTACK#	DTACK#	WAIT#	RDY#
RESET#	RESET#	RESET#	RESET#	RESET#	RESET#	RESET#

### Note

<sup>1</sup> If the target MC68K bus is 32-bit, then these signals should be connected to D[31:16].

## 5.8 LCD Interface Pin Mapping

**Table 5-8 : LCD Interface Pin Mapping**

Pin Name	Monochrome Passive Panel		Color Passive Panel		Color TFT Panel				
	4-bit	8-bit	4-bit	8-bit (format stripe)	9-bit	12-bit	18-bit	18-bit Sharp HR-TFT <sup>1</sup>	
LFRAME	LFRAME							SPS	
LLINE	LLINE							LP	
LSHIFT	LSHIFT							CLK	
LDEN	MOD				LDEN				Drive 0
LDATA0	Drive 0	D0	Drive 0	D0(G3) <sup>2</sup>	R2	R3	R5	R5	
LDATA1	Drive 0	D1	Drive 0	D1(R3) <sup>2</sup>	R1	R2	R4	R4	
LDATA2	Drive 0	D2	Drive 0	D2(B2) <sup>2</sup>	R0	R1	R3	R3	
LDATA3	Drive 0	D3	Drive 0	D3(G2) <sup>2</sup>	G2	G3	G5	G5	
LDATA4	D0	D4	D0(R2) <sup>2</sup>	D4(R2) <sup>2</sup>	G1	G2	G4	G4	
LDATA5	D1	D5	D1(B1) <sup>2</sup>	D5(B1) <sup>2</sup>	G0	G1	G3	G3	
LDATA6	D2	D6	D2(G1) <sup>2</sup>	D6(G1) <sup>2</sup>	B2	B3	B5	B5	
LDATA7	D3	D7	D3(R1) <sup>2</sup>	D7(R1) <sup>2</sup>	B1	B2	B4	B4	
LDATA8	Drive 0	Drive 0	Drive 0	Drive 0	B0	B1	B3	B3	
LDATA9	Drive 0	Drive 0	Drive 0	Drive 0	Drive 0	R0	R2	R2	
LDATA10	Drive 0	Drive 0	Drive 0	Drive 0	Drive 0	Drive 0	R1	R1	
LDATA11	Drive 0	Drive 0	Drive 0	Drive 0	Drive 0	Drive 0	R0	R0	
LDATA12	Drive 0	Drive 0	Drive 0	Drive 0	Drive 0	G0	G2	G2	
LDATA13	Drive 0	Drive 0	Drive 0	Drive 0	Drive 0	Drive 0	G1	G1	
LDATA14	Drive 0	Drive 0	Drive 0	Drive 0	Drive 0	Drive 0	G0	G0	
LDATA15	Drive 0	Drive 0	Drive 0	Drive 0	Drive 0	B0	B2	B2	
LDATA16	Drive 0	Drive 0	Drive 0	Drive 0	Drive 0	Drive 0	B1	B1	
LDATA17	Drive 0	Drive 0	Drive 0	Drive 0	Drive 0	Drive 0	B0	B0	
GPIO0	GPIO0	GPIO0	GPIO0	GPIO0	GPIO0	GPIO0	GPIO0	PS	
GPIO1	GPIO1	GPIO1	GPIO1	GPIO1	GPIO1	GPIO1	GPIO1	CLS	
GPIO2	GPIO2	GPIO2	GPIO2	GPIO2	GPIO2	GPIO2	GPIO2	REV	
GPIO3	GPIO3	GPIO3	GPIO3	GPIO3	GPIO3	GPIO3	GPIO3	SPL	
GPIO4	GPIO4	GPIO4	GPIO4	GPIO4	GPIO4	GPIO4	GPIO4	GPIO4 (output only)	
GPIO5	GPIO5	GPIO5	GPIO5	GPIO5	GPIO5	GPIO5	GPIO5	GPIO5 (output only)	
GPIO6	GPIO6	GPIO6	GPIO6	GPIO6	GPIO6	GPIO6	GPIO6	GPIO6 (output only)	
GPO	GPO (General Purpose Output)								
LCVOUT	LCVOUT								
LPWMOUT	LPWMOUT								

### Note

- <sup>1</sup> GPIO pins must be configured as outputs (CF3 = 0 during RESET# active) when HR-TFT panels are selected.
- <sup>2</sup> These pin mappings use signal names commonly used for each panel type, however signal names may differ between panel manufacturers. The values shown in brackets represent the color components as mapped to the corresponding LDATAxx signals at the first valid edge of LSHIFT. For further LDATAxx to LCD interface mapping, see Section 10.4 "Display Interface".

## 5.9 Data Bus Organization

There are two data bus architectures, little endian and big endian. Little endian means the bytes at lower addresses have lower significance. Big endian means the most significant byte has the lowest address.

**Table 5-9 : Data Bus Organization**

	D[15:8]	D[7:0]
Big endian	2N	2N + 1
Little endian	2N + 1	2N

N : Byte Address

**Table 5-10 : Pin State Summary**

MCU Mode (Endian)	A0	RD/WR#	RD#	WE1#	WE0#	Operation
Generic#1 (Big)	X	0	0	1	1	Word read
	X	0	1	1	1	High byte read 2N
	X	1	0	1	1	Low byte read 2N+1
	X	1	1	0	0	Word write
	X	1	1	0	1	High byte write 2N
	X	1	1	1	0	Low byte write 2N+1
Generic#1 (Little)	X	0	0	1	1	Word read
	X	0	1	1	1	High byte read 2N+1
	X	1	0	1	1	Low byte read 2N
	X	1	1	0	0	Word write
	X	1	1	0	1	High byte write 2N+1
	X	1	1	1	0	Low byte write 2N
Generic#2 (Big)	0	X	0	0	1	Word read
	0	X	0	1	1	High byte read 2N
	1	X	0	0	1	Low byte read 2N+1
	0	X	1	0	0	Word write
	0	X	1	1	0	High byte write 2N
	1	X	1	0	0	Low byte write 2N+1
Generic#2 (Little)	0	X	0	0	1	Word read
	1	X	0	0	1	High byte read 2N+1
	0	X	0	1	1	Low byte read 2N
	0	X	1	0	0	Word write
	1	X	1	0	0	High byte write 2N+1
	0	X	1	1	0	Low byte write 2N
MC68K#1 (Big)	0	1	X	0	X	Word read
	1	1	X	0	X	High byte read 2N
	0	1	X	1	X	Low byte read 2N+1
	0	0	X	0	X	Word write
	1	0	X	0	X	High byte write 2N
	0	0	X	1	X	Low byte write 2N+1
MC68K#1 (Little)	0	1	X	0	X	Word read
	0	1	X	1	X	High byte read 2N+1
	1	1	X	0	X	Low byte read 2N
	0	0	X	0	X	Word write
	0	0	X	1	X	High byte write 2N+1
	1	0	X	0	X	Low byte write 2N

MCU Mode (Endian)	A0	RD/WR#	RD#	WE1#	WE0#	Operation
MC68EZ328 / MC68VZ328 (Big)	X	X	0	X	X	Word read
	X	X	1	0	0	Word write
	X	X	1	0	1	High byte write 2N
	X	X	1	1	0	Low byte write 2N+1
MC68EZ328 / MC68VZ328 (Little)	X	X	0	X	X	Word read
	X	X	1	0	0	Word write
	X	X	1	0	1	High byte write 2N+1
	X	X	1	1	0	Low byte write 2N
SH-3/SH-4 (Big)	X	X	0	1	1	Word read
	X	X	1	0	0	Word write
	X	X	1	0	1	High byte write 2N
	X	X	1	1	0	Low byte write 2N+1
SH-3/SH-4 (Little)	X	X	0	1	1	Word read
	X	X	1	0	0	Word write
	X	X	1	0	1	High byte write 2N+1
	X	X	1	1	0	Low byte write 2N

## 6 FUNCTIONAL BLOCK DESCRIPTIONS

### 6.1 MCU Interface

Responds to bus request for various kinds of MCU and translates to internal interface signals.

### 6.2 Control Register

The control register stores register data to control the LCD panel. The register data is through the MCU Interface read/write to control the register value. The read/write access of LUT is also controlled by the control register. The detail of this register and register mapping will be discussed in Section 7 "Registers".

### 6.3 Display Output

Display output serializes the display data from display buffer and reconstructs the data according to the display panel format. When the display mode is not 16 bpp, display data will be converted to color data by the built-in 18 bit LUT. For details about LUT, please refer to Section 15 "Look-Up Table Architecture".

### 6.4 Display Buffer

Display buffer consists of 256KB SRAM, which is organized as a 32-bit wide internal data path for fast display data retrieval.

### 6.5 PWM Clock and CV Pulse Control

Provides programmable waveform for Pulse Width Modulation (PWM) and Contrast Voltage (CV) generation.

### 6.6 Clock Generator

Clock Generator provides internal clocks. For detail operation of clock generator, please refer to Section 11 "Clocks".

## 7 Registers

This section discusses how and where to access the SSD1906 registers. It also provides detailed information about the layout and usage of each register.

### 7.1 Register Mapping

The SSD1906 registers are memory-mapped. When the system decodes the input pins as CS# = 0 and M/R# = 0, the registers may be accessed. The register space is decoded by A[17:0].

### 7.2 Register Descriptions

Unless specified otherwise, all register bits are set to 0 during power-on or software reset (REG[A2h] bit 0 = 1). All bits marked "0" should be programmed as zero. All bits marked "1" should be programmed as one.

#### Key :

RO : Read Only  
 WO : Write Only  
 RW : Read / Write  
 NA : Not Applicable  
 X : Don't care

#### 7.2.1 Read-Only Configuration Registers

Display Buffer Size Register								REG[01h]
Bit	7	6	5	4	3	2	1	0
	Display Buffer Size Bit 7	Display Buffer Size Bit 6	Display Buffer Size Bit 5	Display Buffer Size Bit 4	Display Buffer Size Bit 3	Display Buffer Size Bit 2	Display Buffer Size Bit 1	Display Buffer Size Bit 0
Type	RO	RO	RO	RO	RO	RO	RO	RO
Reset state	0	1	0	0	0	0	0	0

Bits 7-0

#### Display Buffer Size Bits [7:0]

This register indicates the size of the SRAM display buffer in 4K byte multiple. The SSD1906 display buffer is 256K bytes and therefore this register returns a value of 40h (64).

Value of this register = display buffer size ÷ 4K bytes  
 = 256K bytes ÷ 4K bytes  
 = 40h (64)

Configuration Readback Register								REG[02h]
Bit	7	6	5	4	3	2	1	0
	CF7 Status	CF6 Status	CF5 Status	CF4 Status	CF3 Status	CF2 Status	CF1 Status	CF0 Status
Type	RO	RO	RO	RO	RO	RO	RO	RO
Reset state	X	X	X	X	X	X	X	X

Bits 7-0

#### CF[7:0] Status

These status bits return the status of the configuration pins CF[7:0]. CF[5:0] are latched at the rising edge of RESET# or software reset (REG[A2h] bit 0 = 1).

Product / Revision Code Register							REG[03h]	
Bit	7	6	5	4	3	2	1	0
	Product Code Bit 5	Product Code Bit 4	Product Code Bit 3	Product Code Bit 2	Product Code Bit 1	Product Code Bit 0	Revision Code Bit 1	Revision Code Bit 0
Type	RO	RO	RO	RO	RO	RO	RO	RO
Reset state	0	1	1	1	1	0	X	X

Bits 7-2 **Product Code Bits [5:0]**  
 These are read-only bits that indicate the product code. The product code of SSD1906 is 011110.

Bits 1-0 **Revision Code Bits [1:0]**  
 These are read-only bits that indicate the revision code.

## 7.2.2 Clock Configuration Registers

Memory Clock Configuration Register						REG[04h]		
Bit	7	6	5	4	3	2	1	0
	0	0	MCLK Divide Select Bit 1	MCLK Divide Select Bit 0	0	0	0	0
Type	NA	NA	RW	RW	NA	NA	NA	NA
Reset state	0	0	0	0	0	0	0	0

Bits 5-4 **MCLK Divide Select Bits [1:0]**  
 These bits determine the divide used to generate the Memory Clock (MCLK) from the Bus Clock (BCLK).

Table 7-1 : MCLK Divide Selection

MCLK Divide Select Bits [1:0]	BCLK to MCLK Frequency Ratio
00	1:1
01	2:1
10	3:1
11	4:1

Pixel Clock Configuration Register						REG[05h]		
Bit	7	6	5	4	3	2	1	0
	0	PCLK Divide Select Bit 2	PCLK Divide Select Bit 1	PCLK Divide Select Bit 0	0	0	PCLK Source Select Bit 1	PCLK Source Select Bit 0
Type	NA	RW	RW	RW	NA	NA	RW	RW
Reset state	0	0	0	0	0	0	0	0

Bits 6-4 **PCLK Divide Select Bits [2:0]**  
 These bits determine the divided used to generate the Pixel Clock (PCLK) from the Pixel Clock Source.

**Table 7-2 : PCLK Divide Selection**

PCLK Divide Select Bits [2:0]	PCLK Source to PCLK Frequency Ratio
000	1:1
001	2:1
010	3:1
011	4:1
1XX	8:1

x = don't care

Bits 1-0

**PCLK Source Select Bits [1:0]**

These bits determine the source of the Pixel Clock (PCLK).

**Table 7-3 : PCLK Source Selection**

PCLK Source Select Bits [1:0]	PCLK Source
00	MCLK
01	BCLK
10	CLKI
11	AUXCLK

**7.2.3 Look-Up Table Registers**

Look-Up Table Blue Write Data Register							REG[08h]	
Bit	7	6	5	4	3	2	1	0
	LUT Blue Write Data Bit 5	LUT Blue Write Data Bit 4	LUT Blue Write Data Bit 3	LUT Blue Write Data Bit 2	LUT Blue Write Data Bit 1	LUT Blue Write Data Bit 0	X	X
Type	WO	WO	WO	WO	WO	WO	WO	WO
Reset state	0	0	0	0	0	0	0	0

Bits 7-2

**LUT Blue Write Data Bits [5:0]**

This register contains the data to be written to the blue component of the Look-Up Table.

The data is stored in this register until a write to the LUT Write Address register (REG[0Bh]) moves the data into the Look-Up Table.

**Note**

The LUT entry is updated only when the LUT Write Address Register (REG[0Bh]) is written.

Look-Up Table Green Write Data Register							REG[09h]	
Bit	7	6	5	4	3	2	1	0
	LUT Green Write Data Bit 5	LUT Green Write Data Bit 4	LUT Green Write Data Bit 3	LUT Green Write Data Bit 2	LUT Green Write Data Bit 1	LUT Green Write Data Bit 0	X	X
Type	WO	WO	WO	WO	WO	WO	WO	WO
Reset state	0	0	0	0	0	0	0	0

Bits 7-2

#### LUT Green Write Data Bits [5:0]

This register contains the data to be written to the green component of the Look-Up Table.

The data is stored in this register until a write to the LUT Write Address register (REG[0Bh]) moves the data into the Look-Up Table.

#### Note

The LUT entry is updated only when the LUT Write Address Register (REG[0Bh]) is written.

Look-Up Table Red Write Data Register							REG[0Ah]	
Bit	7	6	5	4	3	2	1	0
	LUT Red Write Data Bit 5	LUT Red Write Data Bit 4	LUT Red Write Data Bit 3	LUT Red Write Data Bit 2	LUT Red Write Data Bit 1	LUT Red Write Data Bit 0	X	X
Type	WO	WO	WO	WO	WO	WO	WO	WO
Reset state	0	0	0	0	0	0	0	0

Bits 7-2

#### LUT Red Write Data Bits [5:0]

This register contains the data to be written to the red component of the Look-Up Table.

The data is stored in this register until a write to the LUT Write Address register (REG[0Bh]) moves the data into the Look-Up Table.

#### Note

The LUT entry is updated only when the LUT Write Address Register (REG[0Bh]) is written.



### Look-Up Table Write Address Register

REG[0Bh]

Bit	7	6	5	4	3	2	1	0
	LUT Write Address Bit 7	LUT Write Address Bit 6	LUT Write Address Bit 5	LUT Write Address Bit 4	LUT Write Address Bit 3	LUT Write Address Bit 2	LUT Write Address Bit 1	LUT Write Address Bit 0
Type	WO	WO	WO	WO	WO	WO	WO	WO
Reset state	0	0	0	0	0	0	0	0

Bits 7-0

#### LUT Write Address Bits [7:0]

This register is a pointer to the Look-Up Table (LUT) which is used to write LUT data stored in REG[08h], REG[09h], and REG[0Ah]. **The data is updated to the LUT only with the completion of a write to this register.** This is a write-only register and returns 00h if read.

#### Note

The SSD1906 has three 256-entry, 6-bit-wide LUTs, one for each of red, green and blue (see Section 15 “Look-Up Table Architecture”).

### Look-Up Table Blue Read Data Register

REG[0Ch]

Bit	7	6	5	4	3	2	1	0
	LUT Blue Read Data Bit 5	LUT Blue Read Data Bit 4	LUT Blue Read Data Bit 3	LUT Blue Read Data Bit 2	LUT Blue Read Data Bit 1	LUT Blue Read Data Bit 0	0	0
Type	RO	RO	RO	RO	RO	RO	RO	RO
Reset state	0	0	0	0	0	0	0	0

Bits 7-2

#### LUT Blue Read Data Bits [5:0]

This register contains the data from the blue component of the Look-Up Table. The LUT entry read is controlled by the LUT Read Address Register (REG[0Fh]).

#### Note

This register is updated only when the LUT Read Address Register (REG[0Fh]) is written.

### Look-Up Table Green Read Data Register

REG[0Dh]

Bit	7	6	5	4	3	2	1	0
	LUT Green Read Data Bit 5	LUT Green Read Data Bit 4	LUT Green Read Data Bit 3	LUT Green Read Data Bit 2	LUT Green Read Data Bit 1	LUT Green Read Data Bit 0	0	0
Type	RO	RO	RO	RO	RO	RO	RO	RO
Reset state	0	0	0	0	0	0	0	0

Bits 7-2

#### LUT Green Read Data Bits [5:0]

This register contains the data from the green component of the Look-Up Table. The LUT entry read is controlled by the LUT Read Address Register (REG[0Fh]).

#### Note

This register is updated only when the LUT Read Address Register (REG[0Fh]) is written.

### Look-Up Table Red Read Data Register

REG[0Eh]

Bit	7	6	5	4	3	2	1	0
	LUT Red Read Data Bit 5	LUT Red Read Data Bit 4	LUT Red Read Data Bit 3	LUT Red Read Data Bit 2	LUT Red Read Data Bit 1	LUT Red Read Data Bit 0	0	0
Type	RO	RO	RO	RO	RO	RO	RO	RO
Reset state	0	0	0	0	0	0	0	0

Bits 7-2

#### LUT Red Read Data Bits [5:0]

This register contains the data from the red component of the Look-Up Table. The LUT entry read is controlled by the LUT Read Address Register (REG[0Fh]).

#### Note

This register is updated only when the LUT Read Address Register (REG[0Fh]) is written.

### Look-Up Table Read Address Register

REG[0Fh]

Bit	7	6	5	4	3	2	1	0
	LUT Read Address Bit 7	LUT Read Address Bit 6	LUT Read Address Bit 5	LUT Read Address Bit 4	LUT Read Address Bit 3	LUT Read Address Bit 2	LUT Read Address Bit 1	LUT Read Address Bit 0
Type	WO	WO	WO	WO	WO	WO	WO	WO
Reset state	0	0	0	0	0	0	0	0

Bits 7-0

#### LUT Read Address Bits [7:0]

This register is a pointer to the Look-Up Table (LUT) which is used to read LUT data and store it in REG[0Ch], REG[0Dh], REG[0Eh]. **The data is read from the LUT only when a write to this register is completed.** This is a write-only register and returns 00h if read.

#### Note

The SSD1906 has three 256-entry, 6-bit-wide LUTs, one for each of red, green and blue (see Section 15 “Look-Up Table Architecture”).

## 7.2.4 Panel Configuration Registers

Panel Type Register								REG[10h]
Bit	7	6	5	4	3	2	1	0
	Color STN Panel Select	Color/Mono Panel Select	Panel Data Width Bit 1	Panel Data Width Bit 0	Active Panel Resolution Select	Panel Type Bit 2	Panel Type Bit 1	Panel Type Bit 0
Type	RW	RW	RW	RW	RW	RW	RW	RW
Reset state	0	0	0	0	0	0	0	0

**Bit 7 Color STN Panel Select**  
 When this bit = 0, non color STN LCD panel is selected.  
 When this bit = 1, color STN LCD panel is selected.

**Bit 6 Color/Mono Panel Select**  
 When this bit = 0, monochrome LCD panel is selected.  
 When this bit = 1, color LCD panel is selected.

**Bits 5-4 Panel Data Width Bits [1:0]**  
 These bits are determined by the data width of the LCD panel. Refer to Table 7-4 : Panel Data Width Selection for the selection.

**Table 7-4 : Panel Data Width Selection**

Panel Data Width Bits [1:0]	Passive Panel Data Width	Active Panel Data Width
00	4-bit	9-bit
01	8-bit	12-bit
10	Reserved	18-bit
11	Reserved	Reserved

**Bit 3 Active Panel Resolution Select**  
 This bit determines one of two panel resolutions when HR-TFT is selected.  
 This bit has no effect unless HR-TFT is selected (REG[10h] bits 2:0 = 010).

**Note**  
 This bit sets some internal non-configurable timing values for the selected panel. However, all panel configuration registers (REG[12h] – REG[40h]) still require programming with the appropriate values for the selected panel.

For panel AC timing, see Section 10.4 “Display Interface”.

**Table 7-5 : Active Panel Resolution Selection**

Active Panel Resolution Select Bit	HR-TFT Resolution
0	160x160
1	320x240

Bits 2-0

**Panel Type Bits[2:0]**

These bits select the panel type.

**Table 7-6 : LCD Panel Type Selection**

Panel Type Bits [2:0]	Panel Type
000	STN
001	TFT
010	HR-TFT
011, 100, 101, 110, 111	Reserved

MOD Rate Register								REG[11h]	
Bit	7	6	5	4	3	2	1	0	
	0	0	MOD Rate Bit 5	MOD Rate Bit 4	MOD Rate Bit 3	MOD Rate Bit 2	MOD Rate Bit 1	MOD Rate Bit 0	
Type	NA	NA	RW	RW	RW	RW	RW	RW	
Reset state	0	0	0	0	0	0	0	0	

Bits 5-0

**MOD Rate Bits [5:0]**

When these bits are all 0, the MOD output signal (LDEN) toggles every LFRAME. For any non-zero value n, the MOD output signal (LDEN) toggles every n LLINE.

**These bits are for passive LCD panels only.**

Horizontal Total Register								REG[12h]	
Bit	7	6	5	4	3	2	1	0	
	0	Horizontal Total Bit 6	Horizontal Total Bit 5	Horizontal Total Bit 4	Horizontal Total Bit 3	Horizontal Total Bit 2	Horizontal Total Bit 1	Horizontal Total Bit 0	
Type	NA	RW	RW	RW	RW	RW	RW	RW	
Reset state	0	0	0	0	0	0	0	0	

Bits 6-0

**Horizontal Total Bits [6:0]**

These bits specify the LCD panel Horizontal Total period, in 8 pixel resolution. The Horizontal Total is the sum of the Horizontal Display period and the Horizontal Non-Display period. The maximum Horizontal Total is 1024 pixels. See Figure 10-12 : Panel Timing Parameters.

$$\text{Horizontal Total in number of pixels} = (\text{Bits [6:0]} + 1) \times 8$$

**Note**

This register must be programmed such that the following condition is fulfilled.  
 $\text{HDPS} + \text{HDP} < \text{HT}$

For panel AC timing and timing parameter definitions, see Section 10.4 “Display Interface”.

Horizontal Display Period Register							REG[14h]	
Bit	7	6	5	4	3	2	1	0
	0	Horizontal Display Period Bit 6	Horizontal Display Period Bit 5	Horizontal Display Period Bit 4	Horizontal Display Period Bit 3	Horizontal Display Period Bit 2	Horizontal Display Period Bit 1	Horizontal Display Period Bit 0
Type	NA	RW	RW	RW	RW	RW	RW	RW
Reset state	0	0	0	0	0	0	0	0

Bits 6-0

### Horizontal Display Period Bits [6:0]

These bits specify the LCD panel Horizontal Display period, in 8 pixel resolution. The Horizontal Display period should be less than the Horizontal Total to allow for a sufficient Horizontal Non-Display period.

Horizontal Display Period in number of pixels = (Bits [6:0] + 1) x 8

#### Note

Maximum value of REG[14h] ≤ 0x3F when Display Rotate Mode (90° or 270°) is selected.

For panel AC timing and timing parameter definitions, see Section 10.4 “Display Interface”.

Horizontal Display Period Start Position Register 0							REG[16h]	
Bit	7	6	5	4	3	2	1	0
	Horizontal Display Period Start Position Bit 7	Horizontal Display Period Start Position Bit 6	Horizontal Display Period Start Position Bit 5	Horizontal Display Period Start Position Bit 4	Horizontal Display Period Start Position Bit 3	Horizontal Display Period Start Position Bit 2	Horizontal Display Period Start Position Bit 1	Horizontal Display Period Start Position Bit 0
Type	RW	RW	RW	RW	RW	RW	RW	RW
Reset state	0	0	0	0	0	0	0	0

Horizontal Display Period Start Position Register 1						REG[17h]		
Bit	7	6	5	4	3	2	1	0
	0	0	0	0	0	0	Horizontal Display Period Start Position Bit 9	Horizontal Display Period Start Position Bit 8
Type	NA	NA	NA	NA	NA	NA	RW	RW
Reset state	0	0	0	0	0	0	0	0

REG[17h] bits1-0,  
REG[16h] bits 7-0

### Horizontal Display Period Start Position Bits [9:0]

These bits specify the Horizontal Display Period Start Position in 1 pixel resolution.

#### Note

For panel AC timing and timing parameter definitions, see Section 10.4 “Display Interface”.

Vertical Total Register 0							REG[18h]	
Bit	7	6	5	4	3	2	1	0
	Vertical Total Bit 7	Vertical Total Bit 6	Vertical Total Bit 5	Vertical Total Bit 4	Vertical Total Bit 3	Vertical Total Bit 2	Vertical Total Bit 1	Vertical Total Bit 0
Type	RW	RW	RW	RW	RW	RW	RW	RW
Reset state	0	0	0	0	0	0	0	0

Bit state 7 6 5 4 3 2 1 0

Vertical Total Register 1							REG[19h]	
Bit	7	6	5	4	3	2	1	0
	0	0	0	0	0	0	Vertical Total Bit 9	Vertical Total Bit 8
Type	NA	NA	NA	NA	NA	NA	RW	RW
Reset state	0	0	0	0	0	0	0	0

REG[19h] bits 1-0,  
REG[18h] bits 7-0

#### Vertical Total Bits [9:0]

These bits specify the LCD panel Vertical Total period, in 1 line resolution. The Vertical Total is the sum of the Vertical Display Period and the Vertical Non-Display Period. The maximum Vertical Total is 1024 lines. See Figure 10-12 : Panel Timing Parameters.

Vertical Total in number of lines = Bits [9:0]+ 1

#### Note

This register must be programmed such that the following condition is fulfilled.  
 $VDPS + VDP < VT$

For panel AC timing and timing parameter definitions, see Section 10.4 “Display Interface”.

Vertical Display Period Register 0							REG[1Ch]	
Bit	7	6	5	4	3	2	1	0
	Vertical Display Period Bit 7	Vertical Display Period Bit 6	Vertical Display Period Bit 5	Vertical Display Period Bit 4	Vertical Display Period Bit 3	Vertical Display Period Bit 2	Vertical Display Period Bit 1	Vertical Display Period Bit 0
Type	RW	RW	RW	RW	RW	RW	RW	RW
Reset state	0	0	0	0	0	0	0	0

Vertical Display Period Register 1							REG[1Dh]	
Bit	7	6	5	4	3	2	1	0
	0	0	0	0	0	0	Vertical Display Period Bit 9	Vertical Display Period Bit 8
Type	NA	NA	NA	NA	NA	NA	RW	RW
Reset state	0	0	0	0	0	0	0	0

REG[1Dh] bits 1-0,  
REG[1Ch] bits 7-0

#### Vertical Display Period Bits [9:0]

These bits specify the LCD panel Vertical Display period, in 1 line resolution. The Vertical Display period should be less than the Vertical Total to allow for a sufficient Vertical Non-Display period.

Vertical Display Period in number of lines = Bits [9:0] + 1

#### Note

For panel AC timing and timing parameter definitions, see Section 10.4 “Display Interface”.

Vertical Display Period Start Position Register 0								REG[1Eh]
Bit	7	6	5	4	3	2	1	0
	Vertical Display Period Start Position Bit 7	Vertical Display Period Start Position Bit 6	Vertical Display Period Start Position Bit 5	Vertical Display Period Start Position Bit 4	Vertical Display Period Start Position Bit 3	Vertical Display Period Start Position Bit 2	Vertical Display Period Start Position Bit 1	Vertical Display Period Start Position Bit 0
Type	RW	RW	RW	RW	RW	RW	RW	RW
Reset state	0	0	0	0	0	0	0	0

Vertical Display Period Start Position Register 1								REG[1Fh]
Bit	7	6	5	4	3	2	1	0
	0	0	0	0	0	0	Vertical Display Start Position Period Bit 9	Vertical Display Start Position Period Bit 8
Type	NA	NA	NA	NA	NA	NA	RW	RW
Reset state	0	0	0	0	0	0	0	0

REG[1Fh] bits 1-0,  
REG[1Eh] bits 7-0

#### Vertical Display Period Start Position Bits [9:0]

These bits specify the Vertical Display Period Start Position in 1 line resolution.

#### Note

For panel AC timing and timing parameter definitions, see Section 10.4 “Display Interface”.

LLINE Pulse Width Register								REG[20h]
Bit	7	6	5	4	3	2	1	0
	LLINE Pulse Polarity	LLINE Pulse Width Bit 6	LLINE Pulse Width Bit 5	LLINE Pulse Width Bit 4	LLINE Pulse Width Bit 3	LLINE Pulse Width Bit 2	LLINE Pulse Width Bit 1	LLINE Pulse Width Bit 0
Type	RW	RW	RW	RW	RW	RW	RW	RW
Reset state	0	0	0	0	0	0	0	0

Bit 7

#### LLINE Pulse Polarity

This bit determines the polarity of the horizontal sync signal. The horizontal sync signal is typically named as LLINE or LP, depending on the panel type.

When this bit = 0, the horizontal sync signal is active low.

When this bit = 1, the horizontal sync signal is active high.

Bits 6-0

#### LLINE Pulse Width Bits [6:0]

These bits specify the width of the panel horizontal sync signal, in number of PCLK. The horizontal sync signal is typically named as LLINE or LP, depending on the panel type.

LLINE Pulse Width in PCLK = Bits [6:0] + 1

#### Note

For panel AC timing and timing parameter definitions, see Section 10.4 “Display Interface”.

<b>LLINE Pulse Start Position Register 0</b>								<b>REG[22h]</b>
Bit	7	6	5	4	3	2	1	0
	LLINE Pulse Start Position Bit 7	LLINE Pulse Start Position Bit 6	LLINE Pulse Start Position Bit 5	LLINE Pulse Start Position Bit 4	LLINE Pulse Start Position Bit 3	LLINE Pulse Start Position Bit 2	LLINE Pulse Start Position Bit 1	LLINE Pulse Start Position Bit 0
Type	RW	RW	RW	RW	RW	RW	RW	RW
Reset state	0	0	0	0	0	0	0	0

<b>LLINE Pulse Start Position Register 1</b>								<b>REG[23h]</b>
Bit	7	6	5	4	3	2	1	0
	0	0	0	0	0	0	LLINE Pulse Start Position Bit 9	LLINE Pulse Start Position Bit 8
Type	NA	NA	NA	NA	NA	NA	RW	RW
Reset state	0	0	0	0	0	0	0	0

REG[23h] bits 1-0,  
REG[22h] bits 7-0

#### **LLINE Pulse Start Position Bits [9:0]**

These bits specify the start position of the horizontal sync signal, in number of PCLK.

LLINE Pulses Start Position in PCLK = Bits [9:0] + 1

#### **Note**

For panel AC timing and timing parameter definitions, see Section 10.4 “Display Interface”.

<b>LFRAME Pulse Width Register</b>							<b>REG[24h]</b>	
Bit	7	6	5	4	3	2	1	0
	LFRAME Pulse Polarity	0	0	0	0	LFRAME Pulse Width Bit 2	LFRAME Pulse Width Bit 1	LFRAME Pulse Width Bit 0
Type	RW	NA	NA	NA	NA	RW	RW	RW
Reset state	0	0	0	0	0	0	0	0

Bit 7

#### **LFRAME Pulse Polarity**

This bit selects the polarity of the vertical sync signal. The vertical sync signal is typically named as LFRAME or SPS, depending on the panel type.

When this bit = 0, the vertical sync signal is active low.

When this bit = 1, the vertical sync signal is active high.

Bits 2-0

#### **LFRAME Pulse Width Bits [2:0]**

These bits specify the width of the panel vertical sync signal, in 1 line resolution. The vertical sync signal is typically named as LFRAME or SPS, depending on the panel type.

LFRAME Pulse Width in number of pixels = (Bits [2:0] + 1) x Horizontal Total + offset

#### **Note**

For panel AC timing and timing parameter definitions, see Section 10.4 “Display Interface”.



<b>LFRAME Pulse Start Position Register 0</b>								<b>REG[26h]</b>
Bit	7	6	5	4	3	2	1	0
	LFRAME Pulse Start Position Bit 7	LFRAME Pulse Start Position Bit 6	LFRAME Pulse Start Position Bit 5	LFRAME Pulse Start Position Bit 4	LFRAME Pulse Start Position Bit 3	LFRAME Pulse Start Position Bit 2	LFRAME Pulse Start Position Bit 1	LFRAME Pulse Start Position Bit 0
Type	RW	RW	RW	RW	RW	RW	RW	RW
Reset state	0	0	0	0	0	0	0	0

<b>LFRAME Pulse Start Position register 1</b>								<b>REG[27h]</b>
Bit	7	6	5	4	3	2	1	0
	0	0	0	0	0	0	LFRAME Pulse Start Position Bit 9	LFRAME Pulse Start Position Bit 8
Type	NA	NA	NA	NA	NA	NA	RW	RW
Reset state	0	0	0	0	0	0	0	0

REG[27h] bits 1-0  
REG[26h] bits 7-0

#### **LFRAME Pulse Start Position Bits [9:0]**

These bits specify the start position of the vertical sync signal, in 1 line resolution.

LFRAME Pulse Start Position in number of pixels = (Bits [9:0]) x Horizontal Total + offset

#### **Note**

For panel AC timing and timing parameter definitions, see Section 10.4 “Display Interface”.

<b>LFRAME Pulse Start Offset Register 0</b>								<b>REG[30h]</b>
Bit	7	6	5	4	3	2	1	0
	LFRAME Start Offset Bit 7	LFRAME Start Offset Bit 6	LFRAME Start Offset Bit 5	LFRAME Start Offset Bit 4	LFRAME Start Offset Bit 3	LFRAME Start Offset Bit 2	LFRAME Start Offset Bit 1	LFRAME Start Offset Bit 0
Type	RW	RW	RW	RW	RW	RW	RW	RW
Reset state	0	0	0	0	0	0	0	0

<b>LFRAME Pulse Start Offset Register 1</b>								<b>REG[31h]</b>
Bit	7	6	5	4	3	2	1	0
	0	0	0	0	0	0	LFRAME Start Offset Bit 9	LFRAME Start Offset Bit 8
Type	NA	NA	NA	NA	NA	NA	RW	RW
Reset state	0	0	0	0	0	0	0	0

REG[31h] bits 1-0  
REG[30h] bits 7-0

#### **LFRAME Pulse Start Offset [9:0]**

These bits specify the start offset of the vertical sync signal within a line, in 1 pixel resolution.

#### **Note**

For panel AC timing and timing parameter definitions, see Section 10.4 “Display Interface”.

<b>LFRAME Pulse Stop Offset Register 0</b>							<b>REG[34h]</b>	
Bit	7	6	5	4	3	2	1	0
	LFRAME Stop Offset Bit 7	LFRAME Stop Offset Bit 6	LFRAME Stop Offset Bit 5	LFRAME Stop Offset Bit 4	LFRAME Stop Offset Bit 3	LFRAME Stop Offset Bit 2	LFRAME Stop Offset Bit 1	LFRAME Stop Offset Bit 0
Type	RW	RW	RW	RW	RW	RW	RW	RW
Reset state	0	0	0	0	0	0	0	0

<b>LFRAME Pulse Stop Offset Register 1</b>							<b>REG[35h]</b>	
Bit	7	6	5	4	3	2	1	0
	0	0	0	0	0	0	LFRAME Stop Offset Bit 9	LFRAME Stop Offset Bit 8
Type	NA	NA	NA	NA	NA	NA	RW	RW
Reset state	0	0	0	0	0	0	0	0

REG[35h] bits 1-0  
REG[34h] bits 7-0

### LFRAME Pulse Stop Offset [9:0]

These bits specify the stop offset of the vertical sync signal within a line, in 1 pixel resolution.

#### Note

For panel AC timing and timing parameter definitions, see Section 10.4 “Display Interface”.

<b>HR-TFT Special Output Register</b>							<b>REG[38h]</b>	
Bit	7	6	5	4	3	2	1	0
	Reserved	GPIO1 Control	GPIO Preset Enable	LSHIFT Polarity swap	LSHIFT Mask	GPIO0 / GPIO1 Swap	PS Alternate	CLS Double
Type	RW	RW	RW	RW	RW	RW	RW	RW
Reset state	0	0	0	0	0	0	0	0

Bit 7

#### Reserved bit

This bit should be programmed by 0.

Bit 6

#### GPIO1 Control

When this bit = 1, GPIO1 should be programmed with the appropriate values with REG[3Ah] and [3Bh].

When this bit = 0, GPIO1 can be toggle once per line.

Bit 5

#### GPIO Preset Enable

When this bit = 1, GPIO0 should be programmed with the appropriate values with REG[3Ch], [3Eh]; GPIO1 can be controlled by REG[38h] bit 6 and GPIO2 should be programmed with REG[40h].

When this bit = 0, GPIO0, GPIO1 and GPIO2 signals are preset to defined values.

Bit 4

#### LSHIFT Polarity Swap

When this bit = 1, LSHIFT signal is falling trigger.

When this bit = 0, LSHIFT signal is rising trigger.

Bit 3

#### LSHIFT Mask

When this bit = 1, LSHIFT signal is enabled in non display period.

When this bit = 0, LSHIFT signal is masked in non display period.

Bit 2

#### GPIO0 / GPIO1 Swap

When this bit = 1, GPIO0 / GPIO1 signals are swapped.

When this bit = 0, GPIO0 / GPIO1 signals are not swapped.

Bit 1

#### PS Alternate

When this bit = 1, PS signal change alternatively.

When this bit = 0, PS signal remain the same.

Bit 0

#### CLS Double

When this bit = 1, number of CLS pulse remain the same.  
 When this bit = 0, number of CLS pulse will be doubled.

**Note**

Bits 6-5 are effective for 320x240 HR-TFT panels only (REG[10h] bits 3-0 = 1010).

Bits 4-2 are effective for HR-TFT panels only (REG[10h] bits 2-0 = 010).

Bits 1-0 are effective for 160x160 HR-TFT panels only (REG[10h] bits 3-0 = 0010).

For panel AC timing and timing parameter definitions, see Section 10.4.8 “160x160 Sharp HR-TFT Panel Timing (e.g. LQ031B1DDxx)” and 10.4.9 “Generic HR-TFT Panel Timing”.

GPIO1 Pulse Start Register								REG[3Ah]
Bit	7	6	5	4	3	2	1	0
	GPIO1 Start Bit 7	GPIO1 Start Bit 6	GPIO1 Start Bit 5	GPIO1 Start Bit 4	GPIO1 Start Bit 3	GPIO1 Start Bit 2	GPIO1 Start Bit 1	GPIO1 Start Bit 0
Type	RW	RW	RW	RW	RW	RW	RW	RW
Reset state	0	0	0	0	0	0	0	0

Bits 7-0

**GPIO1 Pulse Start [7:0]**

These bits specify the start offset of the GPIO1 signal within a line, in 1 pixel resolution. See Figure 7-1 : GPIO Offset for 320x240 HR-TFT.

**Note**

This register must be programmed such that the following condition is fulfilled.

GPIO1 Pulse Stop Value, REG[3Bh] ≥ GPIO1 Pulse Start Value, REG[3Ah]

GPIO1 Pulse Width = (STOP – START + 1) Ts

This register is effective for 320x240 HR-TFT panels and GPIO Preset enabled only (REG[10h] bits 3-0 = 1010 and REG[38h] bit 6-5 = 11).

For panel AC timing and timing parameter definitions, see Section 10.4.9 “Generic HR-TFT Panel Timing”.

GPIO1 Pulse Stop Register								REG[3Bh]
Bit	7	6	5	4	3	2	1	0
	GPIO1 Stop Bit 7	GPIO1 Stop Bit 6	GPIO1 Stop Bit 5	GPIO1 Stop Bit 4	GPIO1 Stop Bit 3	GPIO1 Stop Bit 2	GPIO1 Stop Bit 1	GPIO1 Stop Bit 0
Type	RW	RW	RW	RW	RW	RW	RW	RW
Reset state	0	0	0	0	0	0	0	0

Bits 7-0

**GPIO1 Pulse Stop [7:0]**

These bits specify the stop offset of the GPIO1 signal within a line, in 1 pixel resolution. See Figure 7-1 : GPIO Offset for 320x240 HR-TFT.

**Note**

This register must be programmed such that the following condition is fulfilled.

GPIO1 Pulse Stop Value, REG[3Bh] ≥ GPIO1 Pulse Start Value, REG[3Ah]

GPIO1 Pulse Width = (STOP – START + 1) Ts

This register is effective for 320x240 HR-TFT panels and GPIO Preset enabled only (REG[10h] bits 3-0 = 1010 and REG[38h] bit 6-5 = 11).

For panel AC timing and timing parameter definitions, see Section 10.4.9 “Generic HR-TFT Panel Timing”.

GPIO0 Pulse Start Register								REG[3Ch]
Bit	7	6	5	4	3	2	1	0
	GPIO0 Start Bit 7	GPIO0 Start Bit 6	GPIO0 Start Bit 5	GPIO0 Start Bit 4	GPIO0 Start Bit 3	GPIO0 Start Bit 2	GPIO0 Start Bit 1	GPIO0 Start Bit 0
Type	RW	RW	RW	RW	RW	RW	RW	RW
Reset state	0	0	0	0	0	0	0	0

Bits 7-0

#### GPIO0 Pulse Start [7:0]

These bits specify the start offset of the GPIO0 signal within a line, in 1 pixel resolution. See Figure 7-1 : GPIO Offset for 320x240 HR-TFT.

#### Note

This register must be programmed such that the following condition is fulfilled.

GPIO0 Pulse Stop Value, REG[3Eh] ≥ GPIO0 Pulse Start Value, REG[3Ch]

GPIO0 Pulse Width = (STOP – START + 1) Ts

This register is effective for 320x240 HR-TFT panels and GPIO Preset enabled only (REG[10h] bits 3-0 = 1010 and REG[38h] bit 5 = 1).

For panel AC timing and timing parameter definitions, see Section 10.4.9 “Generic HR-TFT Panel Timing”.

GPIO0 Pulse Stop Register								REG[3Eh]
Bit	7	6	5	4	3	2	1	0
	GPIO0 Stop Bit 7	GPIO0 Stop Bit 6	GPIO0 Stop Bit 5	GPIO0 Stop Bit 4	GPIO0 Stop Bit 3	GPIO0 Stop Bit 2	GPIO0 Stop Bit 1	GPIO0 Stop Bit 0
Type	RW	RW	RW	RW	RW	RW	RW	RW
Reset state	0	0	0	0	0	0	0	0

Bits 7-0

#### GPIO0 Pulse Stop [7:0]

These bits specify the stop offset of the GPIO0 signal within a line, in 1 pixel resolution. See Figure 7-1 : GPIO Offset for 320x240 HR-TFT.

#### Note

This register must be programmed such that the following condition is fulfilled.

GPIO0 Pulse Stop Value, REG[3Eh] ≥ GPIO0 Pulse Start Value, REG[3Ch]

GPIO0 Pulse Width = (STOP – START + 1) Ts

This register is effective for 320x240 HR-TFT panels and GPIO Preset enabled only (REG[10h] bits 3-0 = 1010 and REG[38h] bit 5 = 1).

For panel AC timing and timing parameter definitions, see Section 10.4.9 “Generic HR-TFT Panel Timing”.

GPIO2 Pulse Delay Register								REG[40h]
Bit	7	6	5	4	3	2	1	0
	GPIO2 Delay Bit 7	GPIO2 Delay Bit 6	GPIO2 Delay Bit 5	GPIO2 Delay Bit 4	GPIO2 Delay Bit 3	GPIO2 Delay Bit 2	GPIO2 Delay Bit 1	GPIO2 Delay Bit 0
Type	RW	RW	RW	RW	RW	RW	RW	RW
Reset state	0	0	0	0	0	0	0	0

Bits 7-0

#### GPIO2 Pulse Delay [7:0]

These bits specify the pulse delay of the GPIO2 signal within a line, in 1 pixel resolution. See Figure 7-1 : GPIO Offset for 320x240 HR-TFT.

**Note**

This register is effective for 320x240 HR-TFT panels and GPIO Preset enabled only (REG[10h] bits 3-0 = 1010 and REG[38h] bit 5 = 1).

For panel AC timing and timing parameter definitions, see Section 10.4.9 “Generic HR-TFT Panel Timing”.

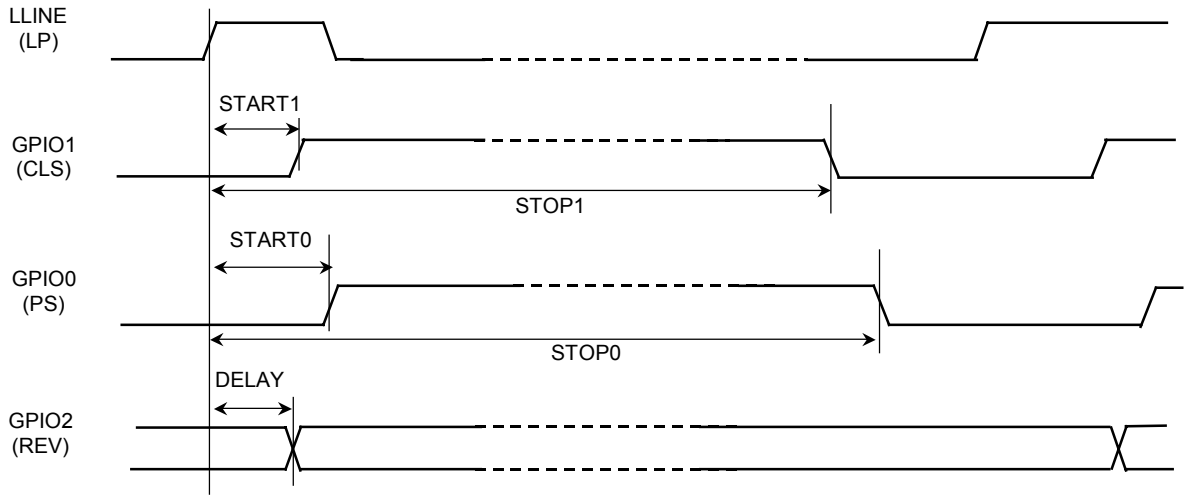

\* For REG[22] = 0,  
 START1 = 0 Ts if REG[3Ah] = 00; STOP1 = n+1 Ts if REG[3Bh] = n  
 START0 = 0 Ts if REG[3Ch] = 00; STOP0 = n+1 Ts if REG[3Eh] = n  
 DELAY = 0 Ts if REG[40h] = 00

**Figure 7-1 : GPIO Offset for 320x240 HR-TFT**

STN Color Depth Control Register							REG[45h]	
Bit	7	6	5	4	3	2	1	0
	0	0	0	0	0	0	0	STN Color Depth Control
Type	NA	NA	NA	NA	NA	NA	NA	RW
Reset state	0	0	0	0	0	0	0	0

Bit 0

**STN Color Depth control**

This bit controls the maximum number of color available for STN panels.

When this bit = 0, it allows maximum 32k color depth.  
 When this bit = 1, it allows maximum 256k color depth.

Refer Table 7-8 : LCD Bit-per-pixel Selection for the color depth relationship.

**Note**

This register is effective for STN panel only (REG[10h] bits 2:0 = 000).  
 This register can be reset by the RESET signal pin only.

Dithering / FRC Control Register							REG[50h]	
Bit	7	6	5	4	3	2	1	0
	Dynamic Dithering Enable	0	0	0	Reserved	Reserved	0	0
Type	RW	NA	NA	NA	RW	RW	NA	NA
Reset state	0	0	0	0	0	0	0	0

**Bit 7**                      **Dynamic Dithering Enable**  
 This bit will enable the dynamic dithering, the dithering mask will change after each 16 frames.

When this bit = 0, dynamic dithering is disabled.  
 When this bit = 1, dynamic dithering is enabled.

**Note**  
 This register is effective for both STN panel and dithering enabled (REG[10h] bits 2:0 = 000 and REG[70h] bit 6 = 0).

**Bits 3-2**                      **Reserved bit**  
 These bits should be programmed by 0.

## 7.2.5 Display Mode Registers

Display Mode Register						REG[70h]		
Bit	7	6	5	4	3	2	1	0
	Display Blank	Dithering Disable	Hardware Color Invert Enable	Software Color Invert	0	Bit-per-pixel Select Bit 2	Bit-per-pixel Select Bit 1	Bit-per-pixel Select Bit 0
Type	RW	RW	RW	RW	NA	RW	RW	RW
Reset state	0	0	0	0	0	0	0	0

**Bit 7**                      **Display Blank**  
 When this bit = 0, the LCD display output is enabled.  
 When this bit = 1, the LCD display output is blank and all LCD data outputs are forced to zero (i.e., the screen is blanked).

**Bit 6**                      **Dithering Disable**  
 SSD1906 use a combination of FRC and 4 pixel square formation dithering to achieve more colors per pixel.

When this bit = 0, dithering is enabled on the passive LCD panel. It allows maximum 64 intensity levels for each color component (RGB).

When this bit = 1, dithering is disabled on the passive LCD panel. It allows maximum 16 intensity levels for each color component (RGB).

**Note**  
 This bit does not refer to the number of simultaneously displayed colors but rather the maximum available colors (refer Table 7-8 : LCD Bit-per-pixel Selection for the maximum number of displayed colors).

**Bit 5**                      **Hardware Color Invert Enable**  
 This bit allows the Color Invert feature to be controlled using the General Purpose IO pin GPIO0. This bit has no effect if REG[70h] bit 7 = 1. **This option is not available if configured for a HR-TFT as GPIO0 is used as an LCD control signal.**

When this bit = 0, GPIO0 has no effect on the display color.  
 When this bit = 1, display color may be inverted via GPIO0.

**Note**

Display color is inverted after the Look-Up Table.  
 The SSD1906 requires some configurations before the hardware color invert feature enabled.

- CF3 must be set to 1 during RESET# is active
- GPIO Pin Input Enable (REG[A9h] bit 7) must be set to 1
- GPIO0 Pin IO Configuration (REG[A8h] bit 0) must be set to 0

If Hardware Color Invert is not available (i.e. HR-TFT panel is used), the color invert function can be controlled by software using REG[70h] bit 4. Table 7-7 : Color Invert Mode Options summarizes the color invert options available.

Bit 4

**Software Color Invert**

When this bit = 0, display color is normal.  
 When this bit = 1, display color is inverted.  
 See Table 7-7 : Color Invert Mode Options. This bit has no effect if REG[70h] bit 7 = 1 or REG[70h] bit 5 = 1.

**Note**

Display color is inverted after the Look-Up Table.

**Table 7-7 : Color Invert Mode Options**

Hardware Color Invert Enable	Software Color Invert	GPIO0	Display Color
0	0	X	Normal
0	1	X	Invert
1	X	0	Normal
1	X	1	Invert

x = don't care

Bits 2-0

**Bit-per-pixel Select Bits [2:0]**

These bits select the color depth (bit-per-pixel) for the displayed data for both the main window and the floating window (if active).

**Note**

1, 2, 4 and 8 bpp modes use the 18-bit LUT, allowing maximum 256K colors. 16 bpp mode bypasses the LUT, allowing 64K colors.

**Table 7-8 : LCD Bit-per-pixel Selection**

Bit-per-pixel Select Bits [2:0]	Color Depth (bpp)	Maximum Number of Colors/Shades			Max. No. Of Simultaneously Displayed Colors/Shades
		Passive Panel (Dithering On)		TFT Panel	
		REG[45h] bit 0 = 0	REG[45h] bit 0 = 1		
000	1 bpp	32K/32	256K/64	256K/64	2/2
001	2 bpp	32K/32	256K/64	256K/64	4/4
010	4 bpp	32K/32	256K/64	256K/64	16/16
011	8 bpp	32K/32	256K/64	256K/64	256/64
100	16 bpp	32K/32	64K/64	64K/64	64K/64
101, 110, 111	Reserved	n/a	n/a	n/a	n/a

Special Effects Register							REG[71h]	
Bit	7	6	5	4	3	2	1	0
	Display Data Word Swap	Display Data Byte Swap	0	Floating Window Enable	0	0	Display Rotate Mode Select Bit 1	Display Rotate Mode Select Bit 0
Type	RW	RW	NA	RW	NA	NA	RW	RW
Reset state	0	0	0	0	0	0	0	0

Bit 7

#### Display Data Word Swap

The display pipe fetches 32-bit of data from the display buffer. This bit enables the lower 16-bit word and the upper 16-bit word to be swapped before sending them to the LCD display. If the Display Data Byte Swap bit is also enabled, then the byte order of the fetched 32-bit data is reversed.

Bit 6

#### Display Data Byte Swap

The display pipe fetches 32-bit of data from the display buffer. This bit enables swapping of byte 0 and byte 1, byte 2 and byte 3, before sending them to the LCD. If the Display Data Word Swap bit is also set, then the byte order of the fetched 32-bit data is reversed.

#### Note

For further information on byte swapping for Big Endian mode, see Section 16 “Big-Endian Bus Interface”.

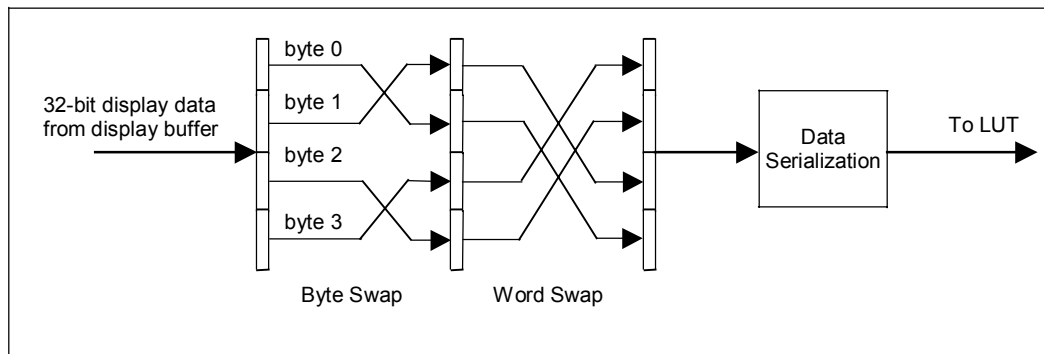

Figure 7-2 : Display Data Byte/Word Swap

Bit 4

#### Floating Window Enable

This bit enables the floating window within the main window used for the Floating Window feature. The location of the floating window within the main window is determined by the Floating Window Position X registers (REG[84h], REG[85h], REG[8Ch], REG[8Dh]) and Floating Window Position Y registers (REG[88h], REG[89h], REG[90h], REG[91h]). The floating window has its own Display Start Address register (REG[7Ch], REG[7Dh], REG[7Eh]) and Memory Address Offset register (REG[80h], REG[81h]). The floating window shares the same color depth and display orientation as the main window.

When this bit = 1, Floating Window is enabled.  
When this bit = 0, Floating Window is disabled.

Bits 1-0

#### Display Rotate Mode Select Bits [1:0]



These bits select different display orientations:

**Table 7-9 : Display Rotate Mode Select Options**

Display Rotate Mode Select Bits [1:0]	Display Orientation
00	0° (Normal)
01	90°
10	180°
11	270°

## 7.2.6 Main Window Registers

Main Window Display Start Address Register 0								REG[74h]
Bit	7	6	5	4	3	2	1	0
	Main window Display Start Address Bit 7	Main window Display Start Address Bit 6	Main window Display Start Address Bit 5	Main window Display Start Address Bit 4	Main window Display Start Address Bit 3	Main window Display Start Address Bit 2	Main window Display Start Address Bit 1	Main window Display Start Address Bit 0
Type	RW	RW	RW	RW	RW	RW	RW	RW
Reset state	0	0	0	0	0	0	0	0

Main Window Display Start Address Register 1								REG[75h]
Bit	7	6	5	4	3	2	1	0
	Main window Display Start Address Bit 15	Main window Display Start Address Bit 14	Main window Display Start Address Bit 13	Main window Display Start Address Bit 12	Main window Display Start Address Bit 11	Main window Display Start Address Bit 10	Main window Display Start Address Bit 9	Main window Display Start Address Bit 8
Type	RW	RW	RW	RW	RW	RW	RW	RW
Reset state	0	0	0	0	0	0	0	0

Main Window Display Start Address Register 2								REG[76h]
Bit	7	6	5	4	3	2	1	0
	0	0	0	0	0	0	0	Main window Display Start Address Bit 16
Type	NA	NA	NA	NA	NA	NA	NA	RW
Reset state	0	0	0	0	0	0	0	0

REG[76h] bit 0,  
REG[75h] bits 7-0,  
REG[74h] bits 7-0

### Main Window Display Start Address Bits [16:0]

These bits form the 17-bit address for the starting double-word of the LCD image in the display buffer for the main window.

**Note that this is a double-word (32-bit) address.** An entry of 00000h into these registers represents the first double-word of display memory, an entry of 00001h

represents the second double-word of the display memory, and so on.

Calculate the Display Start Address as follows :

Main Window Display Start Address Bits 16:0

= Image address ÷ 4 (valid only for Display Rotate Mode 0°)

**Note**

For information on setting this register for other Display Rotate Mode, see Section 18 “Display Rotate Mode”.

Main Window Line Address Offset Register 0								REG[78h]
Bit	7	6	5	4	3	2	1	0
	Main window Line Address Offset Bit 7	Main window Line Address Offset Bit 6	Main window Line Address Offset Bit 5	Main window Line Address Offset Bit 4	Main window Line Address Offset Bit 3	Main window Line Address Offset Bit 2	Main window Line Address Offset Bit 1	Main window Line Address Offset Bit 0
Type	RW	RW	RW	RW	RW	RW	RW	RW
Reset state	0	0	0	0	0	0	0	0

Main Window Line Address Offset Register 1							REG[79h]	
Bit	7	6	5	4	3	2	1	0
	0	0	0	0	0	0	Main window Line Address Offset Bit 9	Main window Line Address Offset Bit 8
Type	NA	NA	NA	NA	NA	NA	RW	RW
Reset state	0	0	0	0	0	0	0	0

REG[79h] bits 1-0,  
REG[78h] bits 7-0

**Main Window Line Address Offset Bits [9:0]**

This register specifies the offset, in double words, from the beginning of one display line to the beginning of the next display line in the main window. **Note that this is a 32-bit address increment.**

Calculate the Line Address Offset as follows :

Main Window Line Address Offset bits 9-0

= Display Width in pixels ÷ (32 ÷ bpp)

**Note**

A virtual display can be created by programming this register with a value greater than the formula requires. When a virtual display is created the image width is larger than the display width and the displayed image becomes a window into the larger virtual image.

## 7.2.7 Floating Window Registers

Floating Window Display Start Address Register 0								REG[7Ch]
Bit	7	6	5	4	3	2	1	0
	Floating Window Display Start Address Bit 7	Floating Window Display Start Address Bit 6	Floating Window Display Start Address Bit 5	Floating Window Display Start Address Bit 4	Floating Window Display Start Address Bit 3	Floating Window Display Start Address Bit 2	Floating Window Display Start Address Bit 1	Floating Window Display Start Address Bit 0
Type	RW	RW	RW	RW	RW	RW	RW	RW
Reset state	0	0	0	0	0	0	0	0

Floating Window Display Start Address Register 1								REG[7Dh]
Bit	7	6	5	4	3	2	1	0
	Floating Window Display Start Address Bit 15	Floating Window Display Start Address Bit 14	Floating Window Display Start Address Bit 13	Floating Window Display Start Address Bit 12	Floating Window Display Start Address Bit 11	Floating Window Display Start Address Bit 10	Floating Window Display Start Address Bit 9	Floating Window Display Start Address Bit 8
Type	RW	RW	RW	RW	RW	RW	RW	RW
Reset state	0	0	0	0	0	0	0	0

Floating Window Display Start Address Register 2							REG[7Eh]	
Bit	7	6	5	4	3	2	1	0
	0	0	0	0	0	0	0	Floating Window Display Start Address Bit 16
Type	NA	NA	NA	NA	NA	NA	NA	RW
Reset state	0	0	0	0	0	0	0	0

REG[7Eh] bit 0,  
REG[7Dh] bits 7-0,  
REG[7Ch] bits 7-0

### Floating Window Display Start Address Bits [16:0]

These bits form the 17-bit address for the starting double-word of the floating window.

**Note that this is a double-word (32-bit) address.** An entry of 00000h into these registers represents the first double-word of display memory, an entry of 00001h represents the second double-word of the display memory, and so on.

### Note

These bits will not effective until the Floating Window Enable bit is set to 1 (REG[71h] bit 4=1).

Floating Window Line Address Offset Register 0							REG[80h]	
Bit	7	6	5	4	3	2	1	0
	Floating Window Line Address Offset Bit 7	Floating Window Line Address Offset Bit 6	Floating Window Line Address Offset Bit 5	Floating Window Line Address Offset Bit 4	Floating Window Line Address Offset Bit 3	Floating Window Line Address Offset Bit 2	Floating Window Line Address Offset Bit 1	Floating Window Line Address Offset Bit 0
Type	RW	RW	RW	RW	RW	RW	RW	RW
Reset state	0	0	0	0	0	0	0	0

Floating Window Line Address Offset Register 1						REG[81h]		
Bit	7	6	5	4	3	2	1	0
	0	0	0	0	0	0	Floating Window Line Address Offset Bit 9	Floating Window Line Address Offset Bit 8
Type	NA	NA	NA	NA	NA	NA	RW	RW
Reset state	0	0	0	0	0	0	0	0

REG[81h] bits 1-0,  
REG[80h] bits 7-0

#### Floating Window Line Address Offset Bits [9:0]

These bits are the LCD display's 10-bit address offset from the starting double-word of line "n" to the starting double-word of line "n + 1" for the floating window. **Note that this is a 32-bit address increment.**

#### Note

These bits will not effective until the Floating Window Enable bit is set to 1 (REG[71h] bit 4=1).

Floating Window Start Position X Register 0							REG[84h]	
Bit	7	6	5	4	3	2	1	0
	Floating Window Start X Position Bit 7	Floating Window Start X Position Bit 6	Floating Window Start X Position Bit 5	Floating Window Start X Position Bit 4	Floating Window Start X Position Bit 3	Floating Window Start X Position Bit 2	Floating Window Start X Position Bit 1	Floating Window Start X Position Bit 0
Type	RW	RW	RW	RW	RW	RW	RW	RW
Reset state	0	0	0	0	0	0	0	0

Floating Window Start Position X Register 1							REG[85h]	
Bit	7	6	5	4	3	2	1	0
	0	0	0	0	0	0	Floating Window Start X Position Bit 9	Floating Window Start X Position Bit 8
Type	NA	NA	NA	NA	NA	NA	RW	RW
Reset state	0	0	0	0	0	0	0	0

REG[85h] bits 1-0,  
REG[84h] bits 7-0

#### Floating Window Start Position X Bits [9:0]

These bits determine the start position X of the floating window in relation to the origin of the panel. Due to the SSD1906 Display Rotate feature, the start position X may not be a horizontal position value (only true in 0° and 180° rotation). For further information on defining the value of the Start Position X register, see Section 19 “Floating Window Mode”.

The value of register is also increased differently based on the display orientation. For 0° and 180° Display Rotate Mode, the start position X is incremented by x pixels where x is relative to the current color depth. Refer to Table 7-10 : 32-bit Address X Increments for Various Color Depths. For 90° and 270° Display Rotate Mode, the start position X is incremented by 1 line.

Depending on the color depth, some of the higher bits in this register are unused because the maximum horizontal display width is 1024 pixels.

#### Note

These bits will not effective until the Floating Window Enable bit is set to 1 (REG[71h] bit 4=1).

**Table 7-10 : 32-bit Address X Increments for Various Color Depths**

Color Depth (bpp)	Pixel Increment (x)
1	32
2	16
4	8
8	4
16	2

Floating Window Start Position Y Register 0							REG[88h]	
Bit	7	6	5	4	3	2	1	0
	Floating Window Start Y Position Bit 7	Floating Window Start Y Position Bit 6	Floating Window Start Y Position Bit 5	Floating Window Start Y Position Bit 4	Floating Window Start Y Position Bit 3	Floating Window Start Y Position Bit 2	Floating Window Start Y Position Bit 1	Floating Window Start Y Position Bit 0
Type	RW	RW	RW	RW	RW	RW	RW	RW
Reset state	0	0	0	0	0	0	0	0

Floating Window Start Position Y Register 1							REG[89h]	
Bit	7	6	5	4	3	2	1	0
	0	0	0	0	0	0	Floating Window Start Y Position Bit 9	Floating Window Start Y Position Bit 8
Type	NA	NA	NA	NA	NA	NA	RW	RW
Reset state	0	0	0	0	0	0	0	0

REG[89h] bits 1-0,  
REG[88h] bits 7-0

#### Floating Window Start Position Y Bits [9:0]

These bits determine the start position Y of the floating window in relation to the origin of the panel. Due to the SSD1906 Display Rotate feature, the start position Y may not be a vertical position value (only true in 0° and 180° Floating Window). For further information on defining the value of the Start Position Y register, see Section 19 “Floating Window Mode”.

The register is also incremented according to the display orientation. For 0° and 180° Display Rotate Mode, the start position Y is incremented by 1 line. For 90° and 270° Display Rotate Mode, the start position Y is incremented by y pixels where y is relative to the current color depth. Refer to Table 7-11 : 32-bit Address Y Increments for Various Color Depths.

Depending on the color depth, some of the higher bits in this register are unused because the maximum vertical display height is 1024 pixels.

#### Note

These bits will not effective until the Floating Window Enable bit is set to 1 (REG[71h] bit 4=1).

**Table 7-11 : 32-bit Address Y Increments for Various Color Depths**

Color Depth (bpp)	Pixel Increment (y)
1	32
2	16
4	8
8	4
16	2

Floating Window End Position X Register 0							REG[8Ch]	
Bit	7	6	5	4	3	2	1	0
	Floating Window End X Position Bit 7	Floating Window End X Position Bit 6	Floating Window End X Position Bit 5	Floating Window End X Position Bit 4	Floating Window End X Position Bit 3	Floating Window End X Position Bit 2	Floating Window End X Position Bit 1	Floating Window End X Position Bit 0
Type	RW	RW	RW	RW	RW	RW	RW	RW
Reset state	0	0	0	0	0	0	0	0

Floating Window End Position X Register 1							REG[8Dh]	
Bit	7	6	5	4	3	2	1	0
	0	0	0	0	0	0	Floating Window End X Position Bit 9	Floating Window End X Position Bit 8
Type	NA	NA	NA	NA	NA	NA	RW	RW
Reset state	0	0	0	0	0	0	0	0

REG[8Dh] bits 1-0,  
REG[8Ch] bits 7-0

#### Floating Window End Position X Bits [9:0]

These bits determine the end position X of the floating window in relation to the origin of the panel. Due to the SSD1906 Display Rotate feature, the end position X may not be a horizontal position value (only true in 0° and 180° rotation). For further information on defining the value of the End Position X register, see 19 “Floating Window Mode”.

The value of register is also increased according to the display orientation. For 0° and 180° Display Rotate Mode, the end position X is incremented by x pixels where x is relative to the current color depth. Refer to Table 7-12 : 32-bit Address X Increments for Various Color Depths. For 90° and 270° Display Rotate Mode, the end position X is incremented by 1 line.

Depending on the color depth, some of the higher bits in this register are unused because the maximum horizontal display width is 1024 pixels.

#### Note

These bits will not effective until the Floating Window Enable bit is set to 1 (REG[71h] bit 4=1).

**Table 7-12 : 32-bit Address X Increments for Various Color Depths**

Color Depth (bpp)	Pixel Increment (x)
1	32
2	16
4	8
8	4
16	2

Floating Window End Position Y Register 0							REG[90h]	
Bit	7	6	5	4	3	2	1	0
	Floating Window End Y Position Bit 7	Floating Window End Y Position Bit 6	Floating Window End Y Position Bit 5	Floating Window End Y Position Bit 4	Floating Window End Y Position Bit 3	Floating Window End Y Position Bit 2	Floating Window End Y Position Bit 1	Floating Window End Y Position Bit 0
Type	RW	RW	RW	RW	RW	RW	RW	RW
Reset state	0	0	0	0	0	0	0	0

Floating Window End Position Y Register 1							REG[91h]	
Bit	7	6	5	4	3	2	1	0
	0	0	0	0	0	0	Floating Window End Y Position Bit 9	Floating Window End Y Position Bit 8
Type	NA	NA	NA	NA	NA	NA	RW	RW
Reset state	0	0	0	0	0	0	0	0

REG[91h] bits 1-0,  
REG[90h] bits 7-0

#### Floating Window End Position Y Bits [9:0]

the panel. Due to the SSD1906 Display Rotate feature, the end position Y may not be a vertical position value (only true in 0° and 180° Display Rotate Mode). For further information on defining the value of the End Position Y register, see Section 19 “Floating Window Mode”.

The value of register is also increased according to the display orientation. For 0° and 180° Display Rotate Mode, the end position Y is incremented by 1 line. For 90° and 270° Display Rotate Mode, the end position Y is incremented by y pixels where y is relative to the current color depth. Refer to Table 7-13 : 32-bit Address Y Increments for Various Color Depths.

Depending on the color depth, some of the higher bits in this register are unused because the maximum vertical display height is 1024 pixels.

#### Note

These bits will not effective until the Floating Window Enable bit is set to 1 (REG[71h] bit 4=1).

**Table 7-13 : 32-bit Address Y Increments for Various Color Depths**

Color Depth (bpp)	Pixel Increment (y)
1	32
2	16
4	8
8	4
16	2

## 7.2.8 Miscellaneous Registers

Power Saving Configuration Register							REG[A0h]	
Bit	7	6	5	4	3	2	1	0
	Vertical Non-Display Period Status	0	0	0	Memory Controller Power Saving Status	0	0	Power Saving Mode Enable
Type	RO	NA	NA	NA	RO	NA	NA	RW
Reset state	1	0	0	0	0	0	0	1



- Bit 7                   **Vertical Non-Display Period Status**  
 When this bit = 0, the LCD panel is in Vertical Display Period.  
 When this bit = 1, the LCD panel is in Vertical Non-Display Period.
- Bit 3                   **Memory Controller Power Saving Status**  
 This bit indicates the Power Saving status of the memory controller.  
 When this bit = 0, the memory controller is powered up.  
 When this bit = 1, the memory controller is powered down.
- Bit 0                   **Power Saving Mode Enable**  
 When this bit = 1, Power Saving mode is enabled.  
 When this bit = 0, Power Saving mode is disabled.

<b>Software Reset Register</b>							<b>REG[A2h]</b>	
Bit	7	6	5	4	3	2	1	0
	0	0	0	0	0	0	0	Software Reset
Type	NA	NA	NA	NA	NA	NA	NA	WO
Reset state	0	0	0	0	0	0	0	0

- Bit 0                   **Software Reset**  
 When a one is written to this bit, **the SSD1906 registers are reset**. This bit has no effect on the contents of the display buffer.

<b>Scratch Pad Register 0</b>							<b>REG[A4h]</b>	
Bit	7	6	5	4	3	2	1	0
	Scratch Pad Bit 7	Scratch Pad Bit 6	Scratch Pad Bit 5	Scratch Pad Bit 4	Scratch Pad Bit 3	Scratch Pad Bit 2	Scratch Pad Bit 1	Scratch Pad Bit 0
Type	RW	RW	RW	RW	RW	RW	RW	RW
Reset state	0	0	0	0	0	0	0	0

<b>Scratch Pad Register 1</b>							<b>REG[A5h]</b>	
Bit	7	6	5	4	3	2	1	0
	Scratch Pad Bit 15	Scratch Pad Bit 14	Scratch Pad Bit 13	Scratch Pad Bit 12	Scratch Pad Bit 11	Scratch Pad Bit 10	Scratch Pad Bit 9	Scratch Pad Bit 8
Type	RW	RW	RW	RW	RW	RW	RW	RW
Reset state	0	0	0	0	0	0	0	0

- REG[A5h] bits 7-0, REG[A4h] bits 7-0                   **Scratch Pad Bits [15:0]**  
 This register contains general purpose read/write bits. These bits have no effect on hardware configuration.

<b>Command Initialization Register</b>							<b>REG[134h]</b>	
Bit	7	6	5	4	3	2	1	0
	Command Initial bit 7	Command Initial bit 6	Command Initial bit 5	Command Initial bit 4	Command Initial bit 3	Command Initial bit 2	Command Initial bit 1	Command Initial bit 0
Type	RW	RW	RW	RW	RW	RW	RW	RW
Reset state	0	0	0	0	0	0	0	0

Bits 7-0 **Command Initialization Bits [7:0]**  
 This is a startup register to initial the SSD1906 which should be programmed with 0x00 before register initialization.

## 7.2.9 General IO Pins Registers

<b>General Purpose I/O Pins Configuration Register 0</b>							<b>REG[A8h]</b>	
Bit	7	6	5	4	3	2	1	0
	0	GPIO6 I/O Configuration	GPIO5 I/O Configuration	GPIO4 I/O Configuration	GPIO3 I/O Configuration	GPIO2 I/O Configuration	GPIO1 I/O Configuration	GPIO0 I/O Configuration
Type	NA	RW	RW	RW	RW	RW	RW	RW
Reset state	0	0	0	0	0	0	0	0

- Bit 6 **GPIO6 I/O Configuration**  
 When this bit = 0, GPIO6 is configured as an input pin.  
 When this bit = 1, GPIO6 is configured as an output pin.
- Bit 5 **GPIO5 I/O Configuration**  
 When this bit = 0, GPIO5 is configured as an input pin.  
 When this bit = 1, GPIO5 is configured as an output pin.
- Bit 4 **GPIO4 I/O Configuration**  
 When this bit = 0, GPIO4 is configured as an input pin.  
 When this bit = 1, GPIO4 is configured as an output pin.
- Bit 3 **GPIO3 I/O Configuration**  
 When this bit = 0, GPIO3 is configured as an input pin.  
 When this bit = 1, GPIO3 is configured as an output pin.
- Bit 2 **GPIO2 I/O Configuration**  
 When this bit = 0, GPIO2 is configured as an input pin.  
 When this bit = 1, GPIO2 is configured as an output pin.
- Bit 1 **GPIO1 I/O Configuration**  
 When this bit = 0, GPIO1 is configured as an input pin.  
 When this bit = 1, GPIO1 is configured as an output pin.
- Bit 0 **GPIO0 I/O Configuration**  
 When this bit = 0, GPIO0 is configured as an input pin.  
 When this bit = 1, GPIO0 is configured as an output pin.

### Note

If CF3 = 0 during RESET# is active, then all GPIO pins are configured as outputs only and this register has no effect. This case allows the GPIO pins to be used by the HR-TFT panel interfaces. For a summary of GPIO usage for HR-TFT, see Table 5-8 : LCD Interface Pin Mapping.

The input functions of the GPIO pins are not enabled until REG[A9h] bit 7 is set to 1.

General Purpose IO Pins Configuration Register 1							REG[A9h]	
Bit	7	6	5	4	3	2	1	0
	GPIO Pin Input Enable	0	0	0	0	0	0	0
Type	RW	NA	NA	NA	NA	NA	NA	NA
Reset state	0	0	0	0	0	0	0	0

**Bit 7 GPIO Pin Input Enable**  
 This bit is used to enable the input function of the GPIO pins. It must be changed to a 1 after power-on reset to enable the input function of the GPIO pins.

General Purpose IO Pins Status/Control Register 0							REG[ACh]	
Bit	7	6	5	4	3	2	1	0
	0	GPIO6 Pin IO Status	GPIO5 Pin IO Status	GPIO4 Pin IO Status	GPIO3 Pin IO Status	GPIO2 Pin IO Status	GPIO1 Pin IO Status	GPIO0 Pin IO Status
Type	NA	RW	RW	RW	RW	RW	RW	RW
Reset state	0	0	0	0	0	0	0	0

**Note**

For information on GPIO pin mapping when HR-TFT panels are selected, see Table 5-2 : LCD Interface Pin Descriptions.

**Bit 6 GPIO6 Pin IO Status**  
 When GPIO6 is configured as an output, writing a 1 to this bit drives GPIO6 high and writing a 0 to this bit drives GPIO6 low.  
 When GPIO6 is configured as an input, a read from this bit returns the status of GPIO6.

**Bit 5 GPIO5 Pin IO Status**  
 When GPIO5 is configured as an output, writing a 1 to this bit drives GPIO5 high and writing a 0 to this bit drives GPIO5 low.  
 When GPIO5 is configured as an input, a read from this bit returns the status of GPIO5.

**Bit 4 GPIO4 Pin IO Status**  
 When GPIO4 is configured as an output, writing a 1 to this bit drives GPIO4 high and writing a 0 to this bit drives GPIO4 low.  
 When GPIO4 is configured as an input, a read from this bit returns the status of GPIO4.

**Bit 3 GPIO3 Pin IO Status**  
 When a HR-TFT panel is not selected (REG[10h] bits 2:0 is not 010) and GPIO3 is configured as an output, writing a 1 to this bit drives GPIO3 high and writing a 0 to this bit drives GPIO3 low.  
 When a HR-TFT panel is not selected (REG[10h] bits 2:0 is not 010) and GPIO3 is configured as an input, a read from this bit returns the status of GPIO3.  
 When a HR-TFT panel is enabled (REG[10h] bits 2:0 = 010), the HR-TFT signal SPL signal is enabled whatever the value of this bit.

Bit 2

**GPIO2 Pin IO Status**

When a HR-TFT panel is not selected (REG[10h] bits 2:0 is not 010) and GPIO2 is configured as an output, writing a 1 to this bit drives GPIO2 high and writing a 0 to this bit drives GPIO2 low.

When a HR-TFT panel is not selected (REG[10h] bits 2:0 is not 010) and GPIO2 is configured as an input, a read from this bit returns the status of GPIO2.

When a HR-TFT panel is enabled (REG[10h] bits 2:0 = 010), the HR-TFT signal REV signal is enabled whatever the value of this bit.

Bit 1

**GPIO1 Pin IO Status**

When a HR-TFT panel is not selected (REG[10h] bits 2:0 is not 010) and GPIO1 is configured as an output, writing a 1 to this bit drives GPIO1 high and writing a 0 to this bit drives GPIO1 low.

When a HR-TFT panel is not selected (REG[10h] bits 2:0 is not 010) and GPIO1 is configured as an input, a read from this bit returns the status of GPIO1.

When a HR-TFT panel is enabled (REG[10h] bits 2:0 = 010), the HR-TFT signal CLS signal is enabled whatever the value of this bit.

Bit 0

**GPIO0 Pin IO Status**

When a HR-TFT panel is not selected (REG[10h] bits 2:0 is not 010) and GPIO0 is configured as an output, writing a 1 to this bit drives GPIO0 high and writing a 0 to this bit drives GPIO0 low.

When a HR-TFT is not selected (REG[10h] bits 2:0 is not 010) and GPIO0 is configured as an input, a read from this bit returns the status of GPIO0.

When a HR-TFT panel is enabled (REG[10h] bits 2:0 = 010), the HR-TFT signal PS signal is enabled whatever the value of this bit.

	<b>General Purpose IO Pins Status/Control Register 1</b>							<b>REG[ADh]</b>
Bit	7	6	5	4	3	2	1	0
	GPO Control	0	0	0	0	0	0	0
Type	RW	NA	NA	NA	NA	NA	NA	NA
Reset state	0	0	0	0	0	0	0	0

Bit 7

**GPO Control**

This bit controls the General Purpose Output pin.

Writing a 0 to this bit drives GPO to low.

Writing a 1 to this bit drives GPO to high.

**Note**

Many implementations use the GPO pin to control the LCD bias power (see Section 10.3, "LCD Power Sequencing").

## 7.2.10 Pulse Width Modulation (PWM) Clock and Contrast Voltage (CV) Pulse Configuration Registers

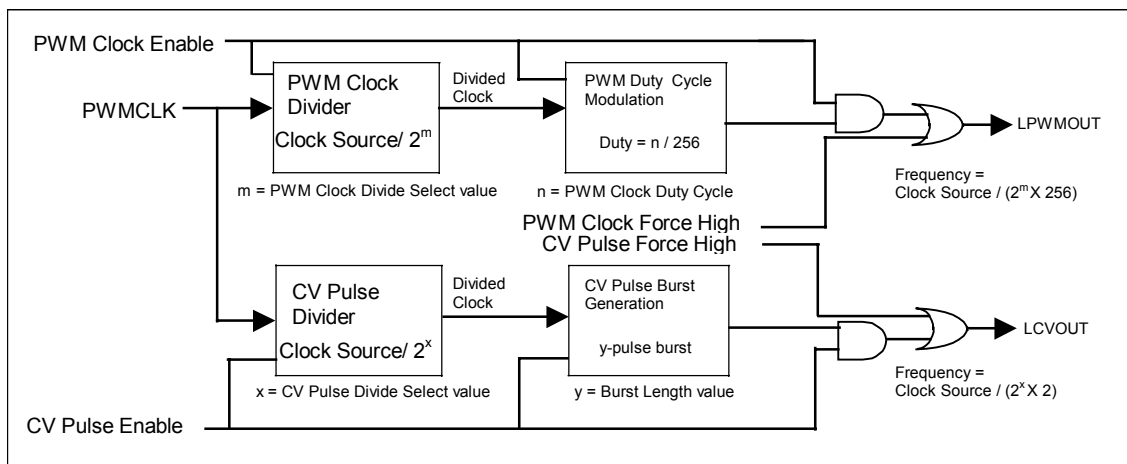

Figure 7-3 : PWM Clock/CV Pulse Block Diagram

### Note

For further information on PWMCLK, see Section 11.1.4 “PWMCLK”.

PWM Clock / CV Pulse Control Register							REG[B0h]	
Bit	7	6	5	4	3	2	1	0
	PWM Clock Force High	0	0	PWM Clock Enable	CV Pulse Force High	CV Pulse Burst Status	CV Pulse Burst Start	CV Pulse Enable
Type	RW	NA	NA	RW	RW	RO	RW	RW
Reset state	0	0	0	0	0	0	0	0

Bit 7 and Bit 4

### PWM Clock Force High (bit 7) and PWM Clock Enable (bit 4)

These bits control the LPWMOUT pin and PWM Clock circuitry as Table 7-14 : PWM Clock Control.

When LPWMOUT is forced low or forced high it can be used as a general purpose output.

### Note

The PWM Clock circuitry is disabled when Power Saving Mode is enabled.

Table 7-14 : PWM Clock Control

Bit 7	Bit 4	Result
0	1	PWM Clock circuitry enabled (controlled by REG[B1h] and REG[B3h])
0	0	LPWMOUT forced low
1	X	LPWMOUT forced high

x = don't care

Bit 3 and Bit 0

**CV Pulse Force High (bit 3) and CV Pulse Enable (bit 0)**

These bits control the LCVOUT pin and CV Pulse circuitry as Table 7-15 : CV Pulse Control.

When LCVOUT is forced low or forced high it can be used as a general purpose output.

**Note**

Bit 3 must be set to 0 and bit 0 must be set to 1 before initiating a new burst using the CV Pulse Burst Start bit.

The CV Pulse circuitry is disabled when Power Saving Mode is enabled.

**Table 7-15 : CV Pulse Control**

Bit 3	Bit 0	Result
0	1	CV Pulse circuitry enabled (controlled by REG[B1h] and REG[B2h])
0	0	LCVOUT forced low
1	x	LCVOUT forced high

x = don't care

Bit 2

**CV Pulse Burst Status**

A "1" indicates a CV pulse burst is occurring. A "0" indicates no CV pulse burst is occurring. Software should wait for this bit to clear before starting another burst.

Bit 1

**CV Pulse Burst Start**

A "1" in this bit initiates a single LCVOUT pulse burst. The number of clock pulses generated is programmable from 1 to 256. The frequency of the pulses is the divided CV Pulse source divided by 2, with 50/50 duty cycle. This bit should be cleared to 0 by software before initiating a new burst.

**Note**

This bit has effect only if the CV Pulse Enable bit is 1.

PWM Clock / CV Pulse Configuration Register							REG[B1h]	
Bit	7	6	5	4	3	2	1	0
	PWM Clock Divide Select Bit 3	PWM Clock Divide Select Bit 2	PWM Clock Divide Select Bit 1	PWM Clock Divide Select Bit 0	CV Pulse Divide Select Bit 2	CV Pulse Divide Select Bit 1	CV Pulse Divide Select Bit 0	PWMCLK Source Select
Type	RW	RW	RW	RW	RW	RW	RW	RW
Reset state	0	0	0	0	0	0	0	0

Bits 7-4

**PWM Clock Divide Select Bits [3:0]**

The value of these bits represents the power of 2 by which the selected PWM clock source is divided.

**Note**

This divided clock is further divided by 256 before it is output at LPWMOUT.

**Table 7-16 : PWM Clock Divide Select Options**

PWM Clock Divide Select Bits [3:0]	PWM Clock Divide Amount
0h	1
1h	2
2h	4
3h	8
...	...
Ch	4096
Dh-Fh	1

Bits 3-1

**CV Pulse Divide Select Bits [2:0]**

The value of these bits represents the power of 2 by which the selected CV Pulse source is divided.

**Note**

This divided clock is further divided by 2 before it is output at the LCVOUT.

**Table 7-17 : CV Pulse Divide Select Options**

CV Pulse Divide Select Bits [2:0]	CV Pulse Divide Amount
0h	1
1h	2
2h	4
3h	8
...	...
7h	128

Bit 0

**PWMCLK Source Select**

When this bit = 0, the clock source for PWMCLK is CLKI.

When this bit = 1, the clock source for PWMCLK is AUXCLK.

**Note**

For further information on the PWMCLK source select, see Section 11 “Clocks”.

CV Pulse Burst Length Register							REG[B2h]	
Bit	7	6	5	4	3	2	1	0
	CV Pulse Burst Length Bit 7	CV Pulse Burst Length Bit 6	CV Pulse Burst Length Bit 5	CV Pulse Burst Length Bit 4	CV Pulse Burst Length Bit 3	CV Pulse Burst Length Bit 2	CV Pulse Burst Length Bit 1	CV Pulse Burst Length Bit 0
Type	RW	RW	RW	RW	RW	RW	RW	RW
Reset state	0	0	0	0	0	0	0	0

Bits 7-0

**CV Pulse Burst Length Bits [7:0]**

The value of this register determines the number of pulses generated in a single CV Pulse burst:

$$\text{Number of pulses in a burst} = \text{Bits [7:0]} + 1$$

LPWMOUT Duty Cycle Register							REG[B3h]	
Bit	7	6	5	4	3	2	1	0
	LPWMOUT Duty Cycle Bit 7	LPWMOUT Duty Cycle Bit 6	LPWMOUT Duty Cycle Bit 5	LPWMOUT Duty Cycle Bit 4	LPWMOUT Duty Cycle Bit 3	LPWMOUT Duty Cycle Bit 2	LPWMOUT Duty Cycle Bit 1	LPWMOUT Duty Cycle Bit 0
Type	RW	RW	RW	RW	RW	RW	RW	RW
Reset state	0	0	0	0	0	0	0	0

Bits 7-0

**LPWMOUT Duty Cycle Bits [7:0]**

This register determines the duty cycle of the LPWMOUT output.

**Table 7-18 : LPWMOUT Duty Cycle Select Options**

LPWMOUT Duty Cycle [7:0]	LPWMOUT Duty Cycle
00h	Always Low
01h	High for 1 out of 256 clock periods
02h	High for 2 out of 256 clock periods
...	...
FFh	High for 255 out of 256 clock periods.

### 7.2.11 Cursor Mode Registers

Cursor Feature Register								REG[C0h]
Bit	7	6	5	4	3	2	1	0
	Cursor1 Enable	Cursor2 Enable	0	0	0	0	0	0
Type	RW	RW	NA	NA	NA	NA	NA	NA
Reset state	0	0	0	0	0	0	0	0

**Bit 7**                    **Cursor1 Enable**  
 When this bit = 0 Cursor1 is disabled.  
 When this bit = 1 Cursor1 is enabled.

**Bit 6**                    **Cursor2 Enable**  
 When this bit = 0, Cursor2 is disabled.  
 When this bit = 1, Cursor2 is enabled.

**Note**

This register is effective for 4/8/16 bpp (REG[70h] Bits 2:0 = 010/011/100)

For Hardware Cursors operation, see Section 20 “Hardware Cursor Mode”.

Cursor1 Blink Total Register 0								REG[C4h]
Bit	7	6	5	4	3	2	1	0
	Cursor1 Blink Total Bit 7	Cursor1 Blink Total Bit 6	Cursor1 Blink Total Bit 5	Cursor1 Blink Total Bit 4	Cursor1 Blink Total Bit 3	Cursor1 Blink Total Bit 2	Cursor1 Blink Total Bit 1	Cursor1 Blink Total Bit 0
Type	RW	RW	RW	RW	RW	RW	RW	RW
Reset state	0	0	0	0	0	0	0	0

Cursor1 Blink Total Register 1							REG[C5h]	
Bit	7	6	5	4	3	2	1	0
	0	0	0	0	0	0	Cursor1 Blink Total Bit 9	Cursor1 Blink Total Bit 8
Type	NA	NA	NA	NA	NA	NA	RW	RW
Reset state	0	0	0	0	0	0	0	0

REG[C5h] bits 1-0,  
 REG[C4h] bits 7-0

**Cursor1 Blink Total Bits [9:0]**

This is the total blinking period per frame for cursor1. This register must be set to a non-zero value in order to make the cursor visible.

**Note**

These bits will not effective until the Cursor1 Enable bit is set to 1 (REG[C0h] bit 7=1).



<b>Cursor1 Blink On Register 0</b>							<b>REG[C8h]</b>	
Bit	7	6	5	4	3	2	1	0
	Cursor1 Blink On Bit 7	Cursor1 Blink On Bit 6	Cursor1 Blink On Bit 5	Cursor1 Blink On Bit 4	Cursor1 Blink On Bit 3	Cursor1 Blink On Bit 2	Cursor1 Blink On Bit 1	Cursor1 Blink On Bit 0
Type	RW	RW	RW	RW	RW	RW	RW	RW
Reset state	0	0	0	0	0	0	0	0

<b>Cursor1 Blink On Register 1</b>							<b>REG[C9h]</b>	
Bit	7	6	5	4	3	2	1	0
	0	0	0	0	0	0	Cursor1 Blink On Bit 9	Cursor1 Blink On Bit 8
Type	NA	NA	NA	NA	NA	NA	RW	RW
Reset state	0	0	0	0	0	0	0	0

REG[C9h] bits 1-0,  
REG[C8h] bits 7-0

#### Cursor1 Blink On Bits [9:0]

This is the blink on frame period for Cursor1. This register must be set to a non-zero value in order to make the cursor1 visible. Also, cursor1 will start to blink if the following conditions are fulfilled :

Cursor1 Blink Total Bits [9:0] > Cursor1 Blink On Bits [9:0] > 0

#### Note

To enable cursor1 without blinking, user must program cursor1 blink on register with a non-zero value, and this value must be greater than or equal to Cursor1 Blink Total Register.

These bits will not effective until the Cursor1 Enable bit is set to 1 (REG[C0h] bit 7=1).

<b>Cursor1 Memory Start Register 0</b>							<b>REG[CCh]</b>	
Bit	7	6	5	4	3	2	1	0
	Cursor1 Memory Start Bit 7	Cursor1 Memory Start Bit 6	Cursor1 Memory Start Bit 5	Cursor1 Memory Start Bit 4	Cursor1 Memory Start Bit 3	Cursor1 Memory Start Bit 2	Cursor1 Memory Start Bit 1	Cursor1 Memory Start Bit 0
Type	RW	RW	RW	RW	RW	RW	RW	RW
Reset state	0	0	0	0	0	0	0	0

<b>Cursor1 Memory Start Register 1</b>							<b>REG[CDh]</b>	
Bit	7	6	5	4	3	2	1	0
	Cursor1 Memory Start Bit 15	Cursor1 Memory Start Bit 14	Cursor1 Memory Start Bit 13	Cursor1 Memory Start Bit 12	Cursor1 Memory Start Bit 11	Cursor1 Memory Start Bit 10	Cursor1 Memory Start Bit 9	Cursor1 Memory Start Bit 8
Type	RW	RW	RW	RW	RW	RW	RW	RW
Reset state	0	0	0	0	0	0	0	0

<b>Cursor1 Memory Start Register 2</b>							<b>REG[CEh]</b>	
Bit	7	6	5	4	3	2	1	0
	0	0	0	0	0	0	0	Cursor1 Memory Start Bit 16
Type	NA	NA	NA	NA	NA	NA	NA	RW
Reset state	0	0	0	0	0	0	0	0

Bit	7	6	5	4	3	2	1	0
state								

REG[CEh] bit 0,  
REG[CDh] bits 7-0,  
REG[CCh] bits 7-0

### Cursor1 Memory Start Bits [16:0]

These bits form the 17-bit address for the starting double-word of the LCD image in the display buffer for the Cursor1 image.

**Note that this is a double-word (32-bit) address.** An entry of 00000h into these registers represents the first double-word of display memory, an entry of 00001h represents the second double-word of the display memory, and so on.  
Calculate the Cursor1 Start Address as follows :

$$\text{Cursor1 Memory Start Bits 16:0} \\ = \text{Cursor Image address} \div 4 \text{ (valid only for Display Rotate Mode } 0^\circ\text{)}$$

### Note

These bits will not effective until the Cursor1 Enable bit is set to 1 (REG[C0h] bit 7=1).

Cursor1 Position X Register 0								REG[D0h]
Bit	7	6	5	4	3	2	1	0
	Cursor1 Position X Bit 7	Cursor1 Position X Bit 6	Cursor1 Position X Bit 5	Cursor1 Position X Bit 4	Cursor1 Position X Bit 3	Cursor1 Position X Bit 2	Cursor1 Position X Bit 1	Cursor1 Position X Bit 0
Type	RW	RW	RW	RW	RW	RW	RW	RW
Reset state	0	0	0	0	0	0	0	0

Cursor1 Position X Register 1								REG[D1h]
Bit	7	6	5	4	3	2	1	0
	0	0	0	0	0	0	Cursor1 Position X Bit 9	Cursor1 Position X Bit 8
Type	NA	NA	NA	NA	NA	NA	RW	RW
Reset state	0	0	0	0	0	0	0	0

REG[D1h] bits 1-0,  
REG[D0h] bits 7-0

### Cursor1 Position X Bits [9:0]

This is starting position X of Cursor1 image. The definition of this register is same as Floating Window Start Position X Register.

### Note

These bits will not effective until the Cursor1 Enable bit is set to 1 (REG[C0h] bit 7=1).

Cursor1 Position Y Register 0								REG[D4h]
Bit	7	6	5	4	3	2	1	0
	Cursor1 Position Y Bit 7	Cursor1 Position Y Bit 6	Cursor1 Position Y Bit 5	Cursor1 Position Y Bit 4	Cursor1 Position Y Bit 3	Cursor1 Position Y Bit 2	Cursor1 Position Y Bit 1	Cursor1 Position Y Bit 0
Type	RW	RW	RW	RW	RW	RW	RW	RW
Reset state	0	0	0	0	0	0	0	0

Cursor1 Position Y Register 1								REG[D5h]
Bit	7	6	5	4	3	2	1	0
	0	0	0	0	0	0	Cursor1 Position Y Bit 9	Cursor1 Position Y Bit 8

Bit	7	6	5	4	3	2	1	0
Type	NA	NA	NA	NA	NA	NA	RW	RW
Reset state	0	0	0	0	0	0	0	0

REG[D5h] bits 1-0,  
REG[D4h] bits 7-0

**Cursor1 Position Y Bits [9:0]**

This is starting position Y of Cursor1 image. The definition of this register is same as Floating Window Y Start Position Register.

**Note**

These bits will not effective until the Cursor1 Enable bit is set to 1 (REG[C0h] bit 7=1).

<b>Cursor1 Horizontal Size Register 0</b>							<b>REG[D8h]</b>	
Bit	7	6	5	4	3	2	1	0
	Cursor1 Horizontal Size Bit 7	Cursor1 Horizontal Size Bit 6	Cursor1 Horizontal Size Bit 5	Cursor1 Horizontal Size Bit 4	Cursor1 Horizontal Size Bit 3	Cursor1 Horizontal Size Bit 2	Cursor1 Horizontal Size Bit 1	Cursor1 Horizontal Size Bit 0
Type	RW	RW	RW	RW	RW	RW	RW	RW
Reset state	0	0	0	0	0	0	0	0

<b>Cursor1 Horizontal Size Register 1</b>							<b>REG[D9h]</b>	
Bit	7	6	5	4	3	2	1	0
	0	0	0	0	0	0	Cursor1 Horizontal Size Bit 9	Cursor1 Horizontal Size Bit 8
Type	NA	NA	NA	NA	NA	NA	RW	RW
Reset state	0	0	0	0	0	0	0	0

REG[D9h] bits 1-0,  
REG[D8h] bits 7-0

**Cursor1 Horizontal Size Bits [9:0]**

These bits specify the horizontal size of Cursor1.

**Note**

The definition of this register varies under different panel orientation and color depth settings.

These bits will not effective until the Cursor1 Enable bit is set to 1 (REG[C0h] bit 7=1).

**Table 7-19 : X Increment Mode for Various Color Depths**

Orientation	Color Depths (bpp)	Increment (x)
0°	4	16 pixels increment e.g. 0000h = 16 pixels; 0001h = 32 pixels
	8	
	16	
90°	4	2 lines increment
	8	4 lines increment
	16	8 lines increment
180°	4	16 pixels increment
	8	
	16	
270°	4	2 lines increment
	8	4 lines increment
	16	8 lines increment

<b>Cursor1 Vertical Size Register 0</b>							<b>REG[DCh]</b>	
Bit	7	6	5	4	3	2	1	0
	Cursor1 Vertical Size Bit 7	Cursor1 Vertical Size Bit 6	Cursor1 Vertical Size Bit 5	Cursor1 Vertical Size Bit 4	Cursor1 Vertical Size Bit 3	Cursor1 Vertical Size Bit 2	Cursor1 Vertical Size Bit 1	Cursor1 Vertical Size Bit 0
Type	RW	RW	RW	RW	RW	RW	RW	RW
Reset state	0	0	0	0	0	0	0	0

<b>Cursor1 Vertical Size Register 1</b>							<b>REG[DDh]</b>	
Bit	7	6	5	4	3	2	1	0
	0	0	0	0	0	0	Cursor1 Vertical Size Bit 9	Cursor1 Vertical Size Bit 8
Type	NA	NA	NA	NA	NA	NA	RW	RW
Reset state	0	0	0	0	0	0	0	0

REG[DDh] bits 1-0,  
REG[DCh] bits 7-0

#### Cursor1 Vertical Size Bits [9:0]

These bits specify the vertical size of Cursor1.

#### Note

The definition of this register varies under different panel orientation and color depth settings.

These bits will not be effective until the Cursor1 Enable bit is set to 1 (REG[C0h] bit 7=1).

**Table 7-20 : Y Increment Mode for Various Color Depths**

Orientation	Color Depths (bpp)	Increment (y)
0°	4	1 line increment e.g. 0000h = 1 line; 0001h = 2 lines
	8	
	16	
90°	4	8 pixels increment
	8	4 pixels increment
	16	2 pixels increment
180°	4	1 line increment
	8	
	16	
270°	4	8 pixels increment
	8	4 pixels increment
	16	2 pixels increment

<b>Cursor1 Color Index1 Register 0</b>							<b>REG[E0h]</b>	
Bit	7	6	5	4	3	2	1	0
	Cursor1 Color Index1 Bit 7	Cursor1 Color Index1 Bit 6	Cursor1 Color Index1 Bit 5	Cursor1 Color Index1 Bit 4	Cursor1 Color Index1 Bit 3	Cursor1 Color Index1 Bit 2	Cursor1 Color Index1 Bit 1	Cursor1 Color Index1 Bit 0
Type	RW	RW	RW	RW	RW	RW	RW	RW
Reset state	0	0	0	0	0	0	0	0

<b>Cursor1 Color Index1 Register 1</b>							<b>REG[E1h]</b>	
Bit	7	6	5	4	3	2	1	0
	Cursor1 Color Index1 Bit 15	Cursor1 Color Index1 Bit 14	Cursor1 Color Index1 Bit 13	Cursor1 Color Index1 Bit 12	Cursor1 Color Index1 Bit 11	Cursor1 Color Index1 Bit 10	Cursor1 Color Index1 Bit 9	Cursor1 Color Index1 Bit 8
Type	RW	RW	RW	RW	RW	RW	RW	RW
Reset state	0	0	0	0	0	0	0	0

REG[E1h] bits 7-0,  
REG[E0h] bits 7-0

#### Cursor1 Color Index1 Bits [15:0]

Each cursor pixel is represented by 2 bits. This register stores the color index for pixel value 01 of Cursor1, refer to Table 20-1.

#### Note

These bits will not effective until the Cursor1 Enable bit is set to 1 (REG[C0h] bit 7=1).

For Hardware Cursors operation, see Section 20 “Hardware Cursor Mode”.

<b>Cursor1 Color Index2 Register 0</b>							<b>REG[E4h]</b>	
Bit	7	6	5	4	3	2	1	0
	Cursor1 Color Index2 Bit 7	Cursor1 Color Index2 Bit 6	Cursor1 Color Index2 Bit 5	Cursor1 Color Index2 Bit 4	Cursor1 Color Index2 Bit 3	Cursor1 Color Index2 Bit 2	Cursor1 Color Index2 Bit 1	Cursor1 Color Index2 Bit 0
Type	RW	RW	RW	RW	RW	RW	RW	RW
Reset state	0	0	0	0	0	0	0	0

<b>Cursor1 Color Index2 Register 1</b>							<b>REG[E5h]</b>	
Bit	7	6	5	4	3	2	1	0
	Cursor1 Color Index2 Bit 15	Cursor1 Color Index2 Bit 14	Cursor1 Color Index2 Bit 13	Cursor1 Color Index2 Bit 12	Cursor1 Color Index2 Bit 11	Cursor1 Color Index2 Bit 10	Cursor1 Color Index2 Bit 9	Cursor1 Color Index2 Bit 8
Type	RW	RW	RW	RW	RW	RW	RW	RW
Reset state	0	0	0	0	0	0	0	0

REG[E5h] bits 7-0,  
REG[E4h] bits 7-0

#### Cursor1 Color Index2 Bits [15:0]

Each cursor pixel is represented by 2 bits. This register stores the color index for pixel value 10 of Cursor1, refer to Table 20-1.

#### Note

These bits will not effective until the Cursor1 Enable bit is set to 1 (REG[C0h] bit 7=1).

For Hardware Cursors operation, see Section 20 “Hardware Cursor Mode”.

<b>Cursor1 Color Index3 Register 0</b>							<b>REG[E8h]</b>	
Bit	7	6	5	4	3	2	1	0
	Cursor1 Color Index3 Bit 7	Cursor1 Color Index3 Bit 6	Cursor1 Color Index3 Bit 5	Cursor1 Color Index3 Bit 4	Cursor1 Color Index3 Bit 3	Cursor1 Color Index3 Bit 2	Cursor1 Color Index3 Bit 1	Cursor1 Color Index3 Bit 0
Type	RW	RW	RW	RW	RW	RW	RW	RW
Reset state	0	0	0	0	0	0	0	0

<b>Cursor1 Color Index3 Register 1</b>							<b>REG[E9h]</b>	
Bit	7	6	5	4	3	2	1	0
	Cursor1 Color Index3 Bit 15	Cursor1 Color Index3 Bit 14	Cursor1 Color Index3 Bit 13	Cursor1 Color Index3 Bit 12	Cursor1 Color Index3 Bit 11	Cursor1 Color Index3 Bit 10	Cursor1 Color Index3 Bit 9	Cursor1 Color Index3 Bit 8
Type	RW	RW	RW	RW	RW	RW	RW	RW
Reset state	0	0	0	0	0	0	0	0

REG[E9h] bits 7-0,  
REG[E8h] bits 7-0

#### Cursor1 Color Index3 Bits [15:0]

Each cursor pixel is represented by 2 bits. This register stores the color index for pixel value 11 of Cursor1, refer to Table 20-1.

#### Note

These bits will not effective until the Cursor1 Enable bit is set to 1 (REG[C0h] bit 7=1).

For Hardware Cursors operation, see Section 20 “Hardware Cursor Mode”.

<b>Cursor2 Blink Total Register 0</b>							<b>REG[ECh]</b>	
Bit	7	6	5	4	3	2	1	0
	Cursor2 Blink Total Bit 7	Cursor2 Blink Total Bit 6	Cursor2 Blink Total Bit 5	Cursor2 Blink Total Bit 4	Cursor2 Blink Total Bit 3	Cursor2 Blink Total Bit 2	Cursor2 Blink Total Bit 1	Cursor2 Blink Total Bit 0
Type	RW	RW	RW	RW	RW	RW	RW	RW
Reset state	0	0	0	0	0	0	0	0

<b>Cursor2 Blink Total Register 1</b>						<b>REG[EDh]</b>		
Bit	7	6	5	4	3	2	1	0
	0	0	0	0	0	0	Cursor2 Blink Total Bit 9	Cursor2 Blink Total Bit 8
Type	NA	NA	NA	NA	NA	NA	RW	RW
Reset state	0	0	0	0	0	0	0	0

REG[EDh] bits 1-0,  
REG[ECh] bits 7-0

#### Cursor2 Blink Total Bits [9:0]

This is the total blinking period per frame for Cursor2. This register must be set to a non-zero value in order to make the cursor visible.

#### Note

These bits will not effective until the Cursor2 Enable bit is set to 1 (REG[C0h] bit 6=1).

<b>Cursor2 Blink On Register 0</b>							<b>REG[F0h]</b>	
Bit	7	6	5	4	3	2	1	0
	Cursor2 Blink On Bit 7	Cursor2 Blink On Bit 6	Cursor2 Blink On Bit 5	Cursor2 Blink On Bit 4	Cursor2 Blink On Bit 3	Cursor2 Blink On Bit 2	Cursor2 Blink On Bit 1	Cursor2 Blink On Bit 0
Type	RW	RW	RW	RW	RW	RW	RW	RW
Reset state	0	0	0	0	0	0	0	0

Cursor2 Blink On Register 1							REG[F1h]	
Bit	7	6	5	4	3	2	1	0
	0	0	0	0	0	0	Cursor2 Blink On Bit 9	Cursor2 Blink On Bit 8
Type	NA	NA	NA	NA	NA	NA	RW	RW
Reset state	0	0	0	0	0	0	0	0

REG[F1h] bits 1-0,  
REG[F0h] bits 7-0

#### Cursor2 Blink On Bits [9:0]

This is the blink on frame period for Cursor2. This register must be set to a non-zero value in order to make the Cursor2 visible. Also, Cursor2 will start to blink if the following conditions are fulfilled:

Cursor2 Blink Total Bits [9:0] > Cursor2 Blink On Bits [9:0] > 0

#### Note

To enable Cursor2 without blinking, user must program Cursor2 Blink On Register with a non-zero value, and this value must be greater than or equal to Cursor2 Blink Total Register.

These bits will not effective until the Cursor2 Enable bit is set to 1 (REG[C0h] bit 6=1).

Cursor2 Memory Start Register 0							REG[F4h]	
Bit	7	6	5	4	3	2	1	0
	Cursor2 Memory Start Bit 7	Cursor2 Memory Start Bit 6	Cursor2 Memory Start Bit 5	Cursor2 Memory Start Bit 4	Cursor2 Memory Start Bit 3	Cursor2 Memory Start Bit 2	Cursor2 Memory Start Bit 1	Cursor2 Memory Start Bit 0
Type	RW	RW	RW	RW	RW	RW	RW	RW
Reset state	0	0	0	0	0	0	0	0

Cursor2 Memory Start Register 1							REG[F5h]	
Bit	7	6	5	4	3	2	1	0
	Cursor2 Memory Start Bit 15	Cursor2 Memory Start Bit 14	Cursor2 Memory Start Bit 13	Cursor2 Memory Start Bit 12	Cursor2 Memory Start Bit 11	Cursor2 Memory Start Bit 10	Cursor2 Memory Start Bit 9	Cursor2 Memory Start Bit 8
Type	RW	RW	RW	RW	RW	RW	RW	RW
Reset state	0	0	0	0	0	0	0	0

Cursor2 Memory Start Register 2							REG[F6h]	
Bit	7	6	5	4	3	2	1	0
	0	0	0	0	0	0	0	Cursor2 Memory Start Bit 16
Type	NA	NA	NA	NA	NA	NA	NA	RW
Reset state	0	0	0	0	0	0	0	0

REG[F6h] bit 0,  
REG[F5h] bits 7-0,  
REG[F4h] bits 7-0

### Cursor2 Memory Start Bits [16:0]

These bits form the 17-bit address for the starting double-word of the LCD image in the display buffer for the Cursor2 image.

**Note that this is a double-word (32-bit) address.** An entry of 00000h into these registers represents the first double-word of display memory, an entry of 00001h represents the second double-word of the display memory, and so on.

Calculate the Cursor2 Start Address as follows :

$$\text{Cursor2 Memory Start Bits 16:0} \\ = \text{Cursor Image address} \div 4 \text{ (valid only for Display Rotate Mode 0°)}$$

### Note

These bits will not effective until the Cursor2 Enable bit is set to 1 (REG[C0h] bit 6=1).

Cursor2 Position X Register 0								REG[F8h]
Bit	7	6	5	4	3	2	1	0
	Cursor2 Position X Bit 7	Cursor2 Position X Bit 6	Cursor2 Position X Bit 5	Cursor2 Position X Bit 4	Cursor2 Position X Bit 3	Cursor2 Position X Bit 2	Cursor2 Position X Bit 1	Cursor2 Position X Bit 0
Type	RW	RW	RW	RW	RW	RW	RW	RW
Reset state	0	0	0	0	0	0	0	0

Cursor2 Position X Register 1								REG[F9h]
Bit	7	6	5	4	3	2	1	0
	0	0	0	0	0	0	Cursor2 Position X Bit 9	Cursor2 Position X Bit 8
Type	NA	NA	NA	NA	NA	NA	RW	RW
Reset state	0	0	0	0	0	0	0	0

REG[F9h] bits 1-0,  
REG[F8h] bits 7-0

### Cursor2 Position X Bits [9:0]

This is starting position X of Cursor2 image. The definition of this register is same as Floating Window Start Position X Register.

### Note

These bits will not effective until the Cursor2 Enable bit is set to 1 (REG[C0h] bit 6=1).

Cursor2 Position Y Register 0								REG[FCh]
Bit	7	6	5	4	3	2	1	0
	Cursor2 Position Y Bit 7	Cursor2 Position Y Bit 6	Cursor2 Position Y Bit 5	Cursor2 Position Y Bit 4	Cursor2 Position Y Bit 3	Cursor2 Position Y Bit 2	Cursor2 Position Y Bit 1	Cursor2 Position Y Bit 0
Type	RW	RW	RW	RW	RW	RW	RW	RW
Reset state	0	0	0	0	0	0	0	0

Cursor2 Position Y Register 1								REG[FDh]
Bit	7	6	5	4	3	2	1	0
	0	0	0	0	0	0	Cursor2 Position Y Bit 9	Cursor2 Position Y Bit 8
Type	NA	NA	NA	NA	NA	NA	RW	RW
Reset state	0	0	0	0	0	0	0	0



REG[FDh] bits 1-0,  
REG[FCh] bits 7-0

**Cursor2 Position Y Bits [9:0]**

This is starting position Y of Cursor2 image. The definition of this register is same as Floating Window Y Start Position Register.

**Note**

These bits will not effective until the Cursor2 Enable bit is set to 1 (REG[C0h] bit 6=1).

<b>Cursor2 Horizontal Size Register 0</b>							<b>REG[100h]</b>	
Bit	7	6	5	4	3	2	1	0
	Cursor2 Horizontal Size Bit 7	Cursor2 Horizontal Size Bit 6	Cursor2 Horizontal Size Bit 5	Cursor2 Horizontal Size Bit 4	Cursor2 Horizontal Size Bit 3	Cursor2 Horizontal Size Bit 2	Cursor2 Horizontal Size Bit 1	Cursor2 Horizontal Size Bit 0
Type	RW	RW	RW	RW	RW	RW	RW	RW
Reset state	0	0	0	0	0	0	0	0

<b>Cursor2 Horizontal Size Register 1</b>							<b>REG[101h]</b>	
Bit	7	6	5	4	3	2	1	0
	0	0	0	0	0	0	Cursor2 Horizontal Size Bit 9	Cursor2 Horizontal Size Bit 8
Type	NA	NA	NA	NA	NA	NA	RW	RW
Reset state	0	0	0	0	0	0	0	0

REG[101h] bits 1-0,  
REG[100h] bits 7-0

**Cursor2 Horizontal Size Bits [9:0]**

These bits specify the horizontal size of Cursor2.

**Note**

The definition of this register varies under different panel orientation and color depth settings. Refer to Table 7-19 : X Increment Mode for Various Color Depths.

These bits will not effective until the Cursor2 Enable bit is set to 1 (REG[C0h] bit 6=1).

<b>Cursor2 Vertical Size Register 0</b>							<b>REG[104h]</b>	
Bit	7	6	5	4	3	2	1	0
	Cursor2 Vertical Size Bit 7	Cursor2 Vertical Size Bit 6	Cursor2 Vertical Size Bit 5	Cursor2 Vertical Size Bit 4	Cursor2 Vertical Size Bit 3	Cursor2 Vertical Size Bit 2	Cursor2 Vertical Size Bit 1	Cursor2 Vertical Size Bit 0
Type	RW	RW	RW	RW	RW	RW	RW	RW
Reset state	0	0	0	0	0	0	0	0

<b>Cursor2 Vertical Size Register 1</b>							<b>REG[105h]</b>	
Bit	7	6	5	4	3	2	1	0
	0	0	0	0	0	0	Cursor2 Vertical Size Bit 9	Cursor2 Vertical Size Bit 8
Type	NA	NA	NA	NA	NA	NA	RW	RW
Reset state	0	0	0	0	0	0	0	0

REG[105h] bits 1-0,  
REG[104h] bits 7-0

**Cursor2 Vertical Size Bits [9:0]**

These bits specify the vertical size of Cursor2.

**Note**

The definition of this register varies under different panel orientation and color depth settings. Refer to Table 7-20 : Y Increment Mode for Various Color Depths.

These bits will not be effective until the Cursor2 Enable bit is set to 1 (REG[C0h] bit 6=1).

<b>Cursor2 Color Index1 Register 0</b>								<b>REG[108h]</b>
Bit	7	6	5	4	3	2	1	0
	Cursor2 Color Index1 Bit 7	Cursor2 Color Index1 Bit 6	Cursor2 Color Index1 Bit 5	Cursor2 Color Index1 Bit 4	Cursor2 Color Index1 Bit 3	Cursor2 Color Index1 Bit 2	Cursor2 Color Index1 Bit 1	Cursor2 Color Index1 Bit 0
Type	RW	RW	RW	RW	RW	RW	RW	RW
Reset state	0	0	0	0	0	0	0	0

<b>Cursor2 Color Index1 Register 1</b>								<b>REG[109h]</b>
Bit	7	6	5	4	3	2	1	0
	Cursor2 Color Index1 Bit 15	Cursor2 Color Index1 Bit 14	Cursor2 Color Index1 Bit 13	Cursor2 Color Index1 Bit 12	Cursor2 Color Index1 Bit 11	Cursor2 Color Index1 Bit 10	Cursor2 Color Index1 Bit 9	Cursor2 Color Index1 Bit 8
Type	RW	RW	RW	RW	RW	RW	RW	RW
Reset state	0	0	0	0	0	0	0	0

REG[109h] bits 7-0  
REG[108h] bits 7-0

**Cursor2 Color Index1 Bits [15:0]**

Each cursor pixel is represented by 2 bits. This register stores the color index for pixel value 01 of Cursor2, refer to Table 20-1.

**Note**

These bits will not be effective until the Cursor2 Enable bit is set to 1 (REG[C0h] bit 6=1).

For Hardware Cursors operation, see Section 20 “Hardware Cursor Mode”.

<b>Cursor2 Color Index2 Register 0</b>								<b>REG[10Ch]</b>
Bit	7	6	5	4	3	2	1	0
	Cursor2 Color Index2 Bit 7	Cursor2 Color Index2 Bit 6	Cursor2 Color Index2 Bit 5	Cursor2 Color Index2 Bit 4	Cursor2 Color Index2 Bit 3	Cursor2 Color Index2 Bit 2	Cursor2 Color Index2 Bit 1	Cursor2 Color Index2 Bit 0
Type	RW	RW	RW	RW	RW	RW	RW	RW
Reset state	0	0	0	0	0	0	0	0

<b>Cursor2 Color Index2 Register 1</b>								<b>REG[10Dh]</b>
Bit	7	6	5	4	3	2	1	0
	Cursor2 Color Index2 Bit 15	Cursor2 Color Index2 Bit 14	Cursor2 Color Index2 Bit 13	Cursor2 Color Index2 Bit 12	Cursor2 Color Index2 Bit 11	Cursor2 Color Index2 Bit 10	Cursor2 Color Index2 Bit 9	Cursor2 Color Index2 Bit 8
Type	RW	RW	RW	RW	RW	RW	RW	RW
Reset state	0	0	0	0	0	0	0	0

REG[10Dh] bits 7-0  
REG[10Ch] bits 7-0

### Cursor2 Color Index2 Bits [15:0]

Each cursor pixel is represented by 2 bits. This register stores the color index for pixel value 10 of Cursor2, refer to Table 20-1.

#### Note

These bits will not effective until the Cursor2 Enable bit is set to 1 (REG[C0h] bit 6=1).

For Hardware Cursors operation, see Section 20 “Hardware Cursor Mode”.

Cursor2 Color Index3 Register 0								REG[110h]
Bit	7	6	5	4	3	2	1	0
	Cursor2 Color Index3 Bit 7	Cursor2 Color Index3 Bit 6	Cursor2 Color Index3 Bit 5	Cursor2 Color Index3 Bit 4	Cursor2 Color Index3 Bit 3	Cursor2 Color Index3 Bit 2	Cursor2 Color Index3 Bit 1	Cursor2 Color Index3 Bit 0
Type	RW	RW	RW	RW	RW	RW	RW	RW
Reset state	0	0	0	0	0	0	0	0

Cursor2 Color Index3 Register 1								REG[111h]
Bit	7	6	5	4	3	2	1	0
	Cursor2 Color Index3 Bit 15	Cursor2 Color Index3 Bit 14	Cursor2 Color Index3 Bit 13	Cursor2 Color Index3 Bit 12	Cursor2 Color Index3 Bit 11	Cursor2 Color Index3 Bit 10	Cursor2 Color Index3 Bit 9	Cursor2 Color Index3 Bit 8
Type	RW	RW	RW	RW	RW	RW	RW	RW
Reset state	0	0	0	0	0	0	0	0

REG[111h] bits 7-0  
REG[110h] bits 7-0

### Cursor2 Color Index3 Bits [15:0]

Each cursor pixel is represented by 2 bits. This register stores the color index for pixel value 11 of Cursor2, refer to Table 20-1.

#### Note

These bits will not effective until the Cursor2 Enable bit is set to 1 (REG[C0h] bit 6=1).

For Hardware Cursors operation, see Section 20 “Hardware Cursor Mode”.

## 8 MAXIMUM RATINGS

Table 8-1 : Absolute Maximum Ratings

Symbol	Parameter	Rating	Units
IOV <sub>DD</sub>	Supply Voltage	V <sub>SS</sub> - 0.3 to 4.0	V
V <sub>IN</sub>	Input Voltage	V <sub>SS</sub> - 0.3 to 5.0	V
V <sub>OUT</sub>	Output Voltage	V <sub>SS</sub> - 0.3 to IOV <sub>DD</sub> + 0.5	V
T <sub>STG</sub>	Storage Temperature	-65 to 150	°C
T <sub>SOL</sub>	Solder Temperature/Time	260 for 10 sec. max at lead	°C

Maximum Ratings are those values beyond which damage to the device may occur. Functional operation should be restricted to the limits in the Electrical Characteristics tables or Pin Description section.

This device contains circuitry to protect the inputs against damage due to high static voltages or electric fields; however, it is advised that normal precautions to be taken to avoid application of any voltage higher than maximum rated voltages to this high impedance circuit. For proper operation it is recommended that V<sub>IN</sub> and V<sub>OUT</sub> be

constrained to the range  $V_{SS} \leq (V_{IN} \text{ or } V_{OUT}) \leq IOV_{DD}$ . Reliability of operation is enhanced if unused input are connected to an appropriate logic voltage level (e.g., either  $V_{SS}$  or  $IOV_{DD}$ ). This device is not radiation protected.

**Table 8-2 : Recommended Operating Conditions**

Symbol	Parameter	Condition	Min	Typ	Max	Units
$IOV_{DD}$	Supply Voltage	$V_{SS} = 0V$	3.0	3.3	3.6	V
$V_{IN}$	Input Voltage		$V_{SS}$		$IOV_{DD}$	V
$T_{OPR}$	Operating Temperature		-30	25	85	°C

## 9 DC CHARACTERISTICS

**Table 9-1 : Electrical Characteristics for  $IOV_{DD} = 3.3V$  typical**

Symbol	Parameter	Condition	Min	Typ	Max	Units
$I_{DDs}$	Quiescent Current	Quiescent Conditions			120	$\mu A$
$I_{IZ}$	Input Leakage Current		-1		1	$\mu A$
$I_{OZ}$	Output Leakage Current		-1		1	$\mu A$
$V_{OH}$	High Level Output Voltage	$IOV_{DD} = \text{min}$ $I_{OH} = -8mA$ (Type 2) $-12mA$ (Type 3)	$IOV_{DD} - 0.4$			V
$V_{OL}$	Low Level Output Voltage	$IOV_{DD} = \text{min}$ $I_{OL} = 8mA$ (Type 2) $12mA$ (Type 3)			0.4	V
$V_{IH}$	High Level Input Voltage	LVTTL Level, $IOV_{DD} = \text{max}$	$IOV_{DD} - 0.8$			V
$V_{IL}$	Low Level Input Voltage	LVTTL Level, $IOV_{DD} = \text{min}$			0.8	V
$V_{T+}$	High Level Input Voltage	LVTTL Schmitt	1.1			V
$V_{T-}$	Low Level Input Voltage	LVTTL Schmitt			0.94	V
$V_{H1}$	Hysteresis Voltage	LVTTL Schmitt	0.15			V
$C_I$	Input Pin Capacitance				10	pF
$C_O$	Output Pin Capacitance				10	pF
$C_{IO}$	Bi-Directional Pin Capacitance				10	pF

## 10 AC CHARACTERISTICS

Conditions:  $IOV_{DD} = 3.3V \pm 10\%$   
 $T_A = -30^\circ C$  to  $85^\circ C$   
 $T_{rise}$  and  $T_{fall}$  for all inputs must be  $< 5$  ns (10% ~ 90%)  
 $C_L = 50pF$  (Bus/CPU Interface)  
 $C_L = 0pF$  (LCD Panel Interface)

## 10.1 Clock Timing

### 10.1.1 Input Clocks

Clock Input Waveform

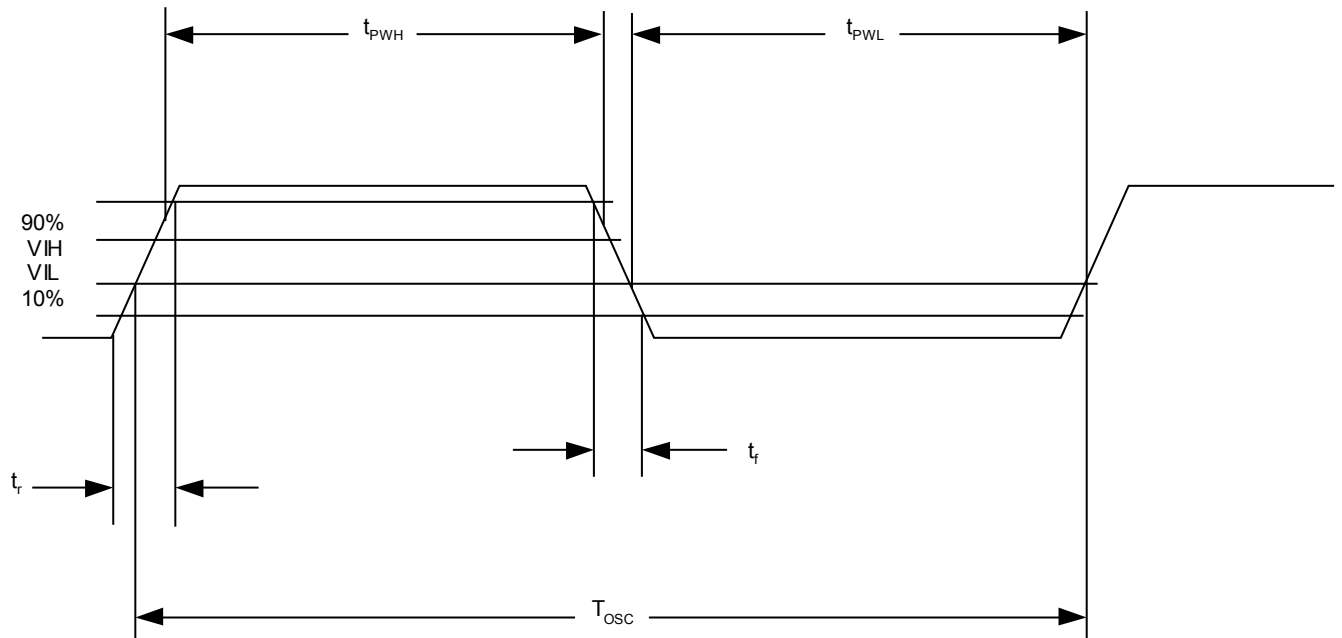

Figure 10-1 : Clock Input Requirements

Table 10-1 : Clock Input Requirements for CLKI

Symbol	Parameter	Min	Max	Units
$f_{osc}$	Input Clock Frequency (CLKI)		66	MHz
$T_{osc}$	Input Clock period (CLKI)	$1/f_{osc}$		ns
$t_{PWH}$	Input Clock Pulse Width High (CLKI)	5		ns
$t_{PWL}$	Input Clock Pulse Width Low (CLKI)	5		ns
$t_f$	Input Clock Fall Time (10% - 90%)		5	ns
$t_r$	Input Clock Rise Time (10% - 90%)		5	ns

#### Note

Maximum internal requirements for clocks derived from CLKI must be considered when determining the frequency of CLKI. See Section 10.1.2 "Internal Clocks" for internal clock requirements.

**Table 10-2 : Clock Input Requirements for AUXCLK**

Symbol	Parameter	Min	Max	Units
$f_{OSC}$	Input Clock Frequency (AUXCLK)		66	MHz
$T_{OSC}$	Input Clock period (AUXCLK)	$1/f_{OSC}$		ns
$t_{PWH}$	Input Clock Pulse Width High (AUXCLK)	5		ns
$t_{PWL}$	Input Clock Pulse Width Low (AUXCLK)	5		ns
$t_f$	Input Clock Fall Time (10% - 90%)		5	ns
$t_r$	Input Clock Rise Time (10% - 90%)		5	ns

**Note :**

Maximum internal requirements for clocks derived from AUXCLK must be considered when determining the frequency of AUXCLK. See Section 10.1.2 “Internal Clocks” for internal clock requirements.

**10.1.2 Internal Clocks****Table 10-3 : Internal Clock Requirements**

Symbol	Parameter	Min	Max	Units
$f_{BCLK}$	Bus Clock frequency		66	MHz
$f_{MCLK}$	Memory Clock frequency		55	MHz
$f_{PCLK}$	Pixel Clock frequency		55	MHz
$f_{PWMCLK}$	PWM Clock frequency		66	MHz

**Note :**

For further information on internal clocks, refer to Section 11 “Clocks”.

## 10.2 CPU Interface Timing

The following section are CPU interface AC Timing based on  $IOV_{DD} = 3.3V$ .

### 10.2.1 Generic #1 Interface Timing

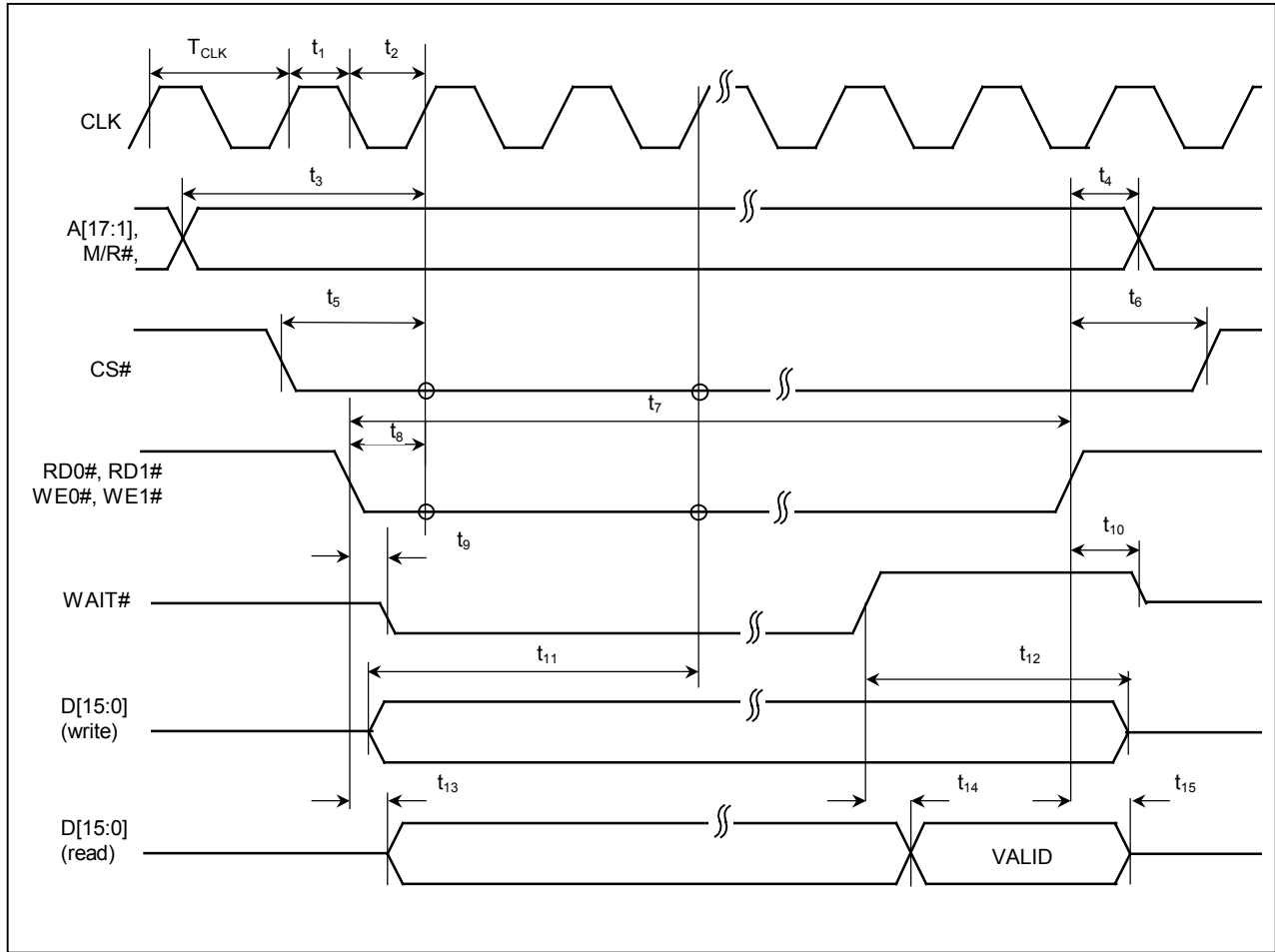

Figure 10-2 : Generic #1 Interface Timing

**Table 10-4 : Generic #1 Interface Timing**

Symbol	Parameter	Min	Max	Units
$f_{CLK}$	Bus Clock frequency		66	MHz
$T_{CLK}$	Bus Clock period	$1/f_{CLK}$		ns
$t_1$	Clock pulse width high	6		ns
$t_2$	Clock pulse width low	6		ns
$t_3$	A[17:1], M/R# setup to first CLK rising edge where CS# = 0 and either RD0#, RD1# = 0 or WE0#, WE1# = 0	1		ns
$t_4$	A[17:1], M/R# hold from either RD0#, RD1# or WE0#, WE1# rising edge	0		ns
$t_5$	CS# setup to CLK rising edge	1		ns
$t_6$	CS# hold from either RD0#, RD1# or WE0#, WE1# rising edge	1		ns
$t_{7a}$	RD0#, RD1#, WE0#, WE1# asserted for MCLK = BCLK		13	TCLK
$t_{7b}$	RD0#, RD1#, WE0#, WE1# asserted for MCLK = BCLK +2		18	TCLK
$t_{7c}$	RD0#, RD1#, WE0#, WE1# asserted for MCLK = BCLK +3		23	TCLK
$t_{7d}$	RD0#, RD1#, WE0#, WE1# asserted for MCLK = BCLK +4		28	TCLK
$t_8$	RD0#, RD1#, WE0#, WE1# setup to CLK rising edge	1		ns
$t_9$	Falling edge of either RD0#, RD1# or WE0#, WE1# to WAIT# driven low	3	15	ns
$t_{10}$	Rising edge of either RD0#, RD1# or WE0#, WE1# to WAIT# high impedance	3	13	ns
$t_{11}$	D[15:0] setup to third CLK rising edge where CS# = 0 and WE0#, WE1#=0 (write cycle)(see note 1)	0		ns
$t_{12}$	D[15:0] hold from WAIT# rising edge (write cycle)	0		ns
$t_{13}$	RD0#, RD1# falling edge to D[15:0] driven (read cycle)	3	14	ns
$t_{14}$	WAIT# rising edge to D[15:0] valid (read cycle)		2	ns
$t_{15}$	RD0#, RD1# rising edge to D[15:0] high impedance (read cycle)	3	11	ns

1.  $t_{11}$  is the delay from when data is placed on the bus until the data is latched into the write buffer.



## 10.2.2 Generic #2 Interface Timing (e.g. ISA)

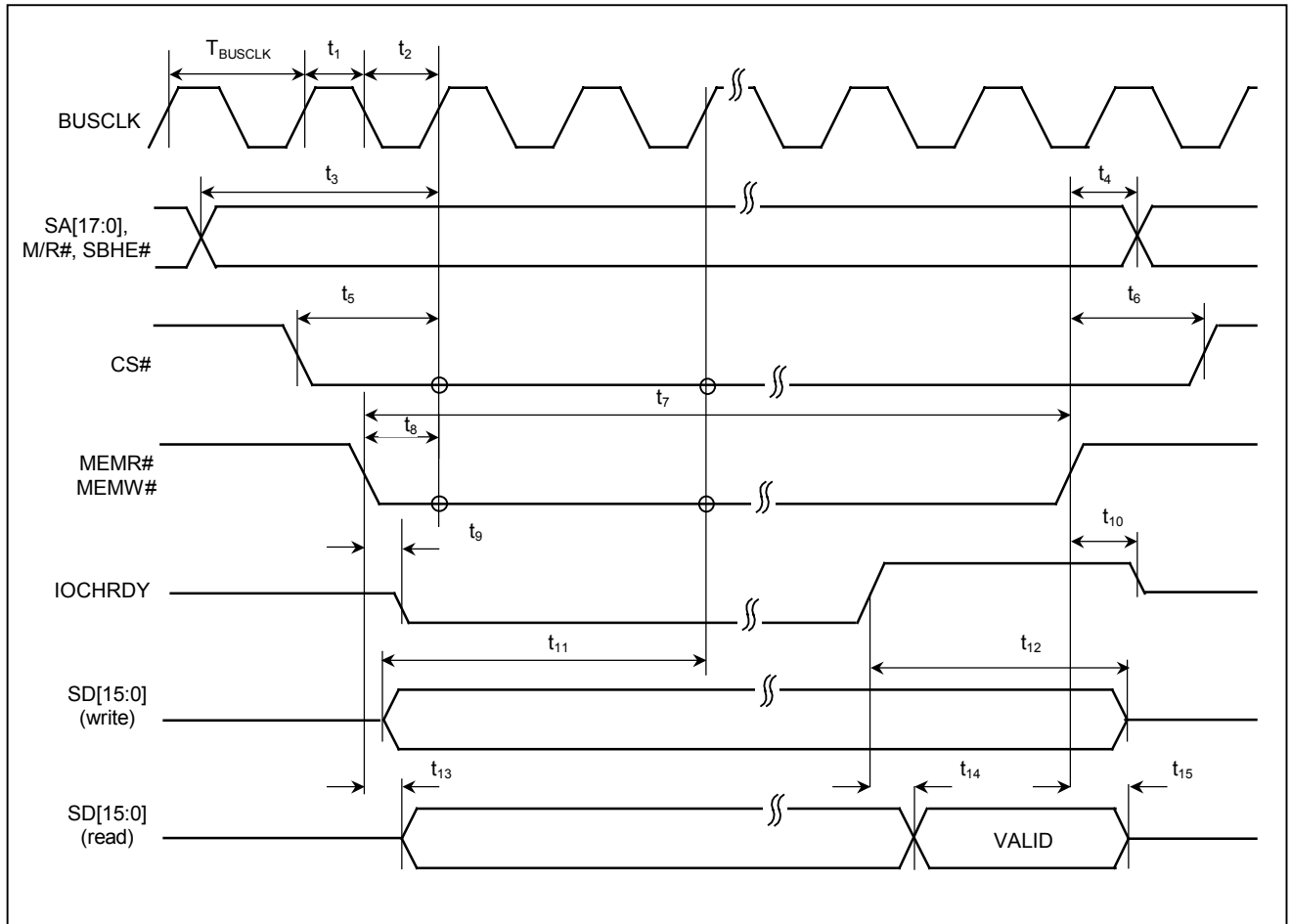

Figure 10-3 : Generic #2 Interface Timing

**Table 10-5 : Generic #2 Interface Timing**

Symbol	Parameter	Min	Max	Units
$f_{\text{BUSCLK}}$	Bus Clock frequency		66	MHz
$T_{\text{BUSCLK}}$	Bus Clock period	$1/f_{\text{BUSCLK}}$		ns
$t_1$	Clock pulse width high	6		ns
$t_2$	Clock pulse width low	6		ns
$t_3$	SA[17:0], M/R#, SBHE# setup to first BUSCLK rising edge where CS# = 0 and either MEMR# = 0 or MEMW# = 0	1		ns
$t_4$	SA[17:0], M/R#, SBHE# hold from either MEMR# or MEMW# rising edge	0		ns
$t_5$	CS# setup to BUSCLK rising edge	1		ns
$t_6$	CS# hold from either MEMR# or MEMW# rising edge	0		ns
$t_{7a}$	MEMR# or MEMW# asserted for MCLK = BCLK		13	$T_{\text{BUSCLK}}$
$t_{7b}$	MEMR# or MEMW# asserted for MCLK = BCLK +2		18	$T_{\text{BUSCLK}}$
$t_{7c}$	MEMR# or MEMW# asserted for MCLK = BCLK +3		23	$T_{\text{BUSCLK}}$
$t_{7d}$	MEMR# or MEMW# asserted for MCLK = BCLK +4		28	$T_{\text{BUSCLK}}$
$t_8$	MEMR# or MEMW# setup to BUSCLK rising edge	1		ns
$t_9$	Falling edge of either MEMR# or MEMW# to IOCHRDY driven low	3	15	ns
$t_{10}$	Rising edge of either MEMR# or MEMW# to IOCHRDY high impedance	3	13	ns
$t_{11}$	SD[15:0] setup to third BUSCLK rising edge where CS# = 0 and MEMW#=0 (write cycle)(see note1)	0		ns
$t_{12}$	SD[15:0] hold from IOCHRDY rising edge (write cycle)	0		ns
$t_{13}$	MEMR# falling edge to SD[15:0] driven (read cycle)	3	13	ns
$t_{14}$	IOCHRDY rising edge to SD[15:0] valid (read cycle)		2	ns
$t_{15}$	Rising edge of MEMR# to SD[15:0] high impedance (read cycle)	3	12	ns

1.  $t_{11}$  is the delay from when data is placed on the bus until the data is latched into the write buffer.

### 10.2.3 Motorola MC68K #1 Interface Timing (e.g. MC68000)

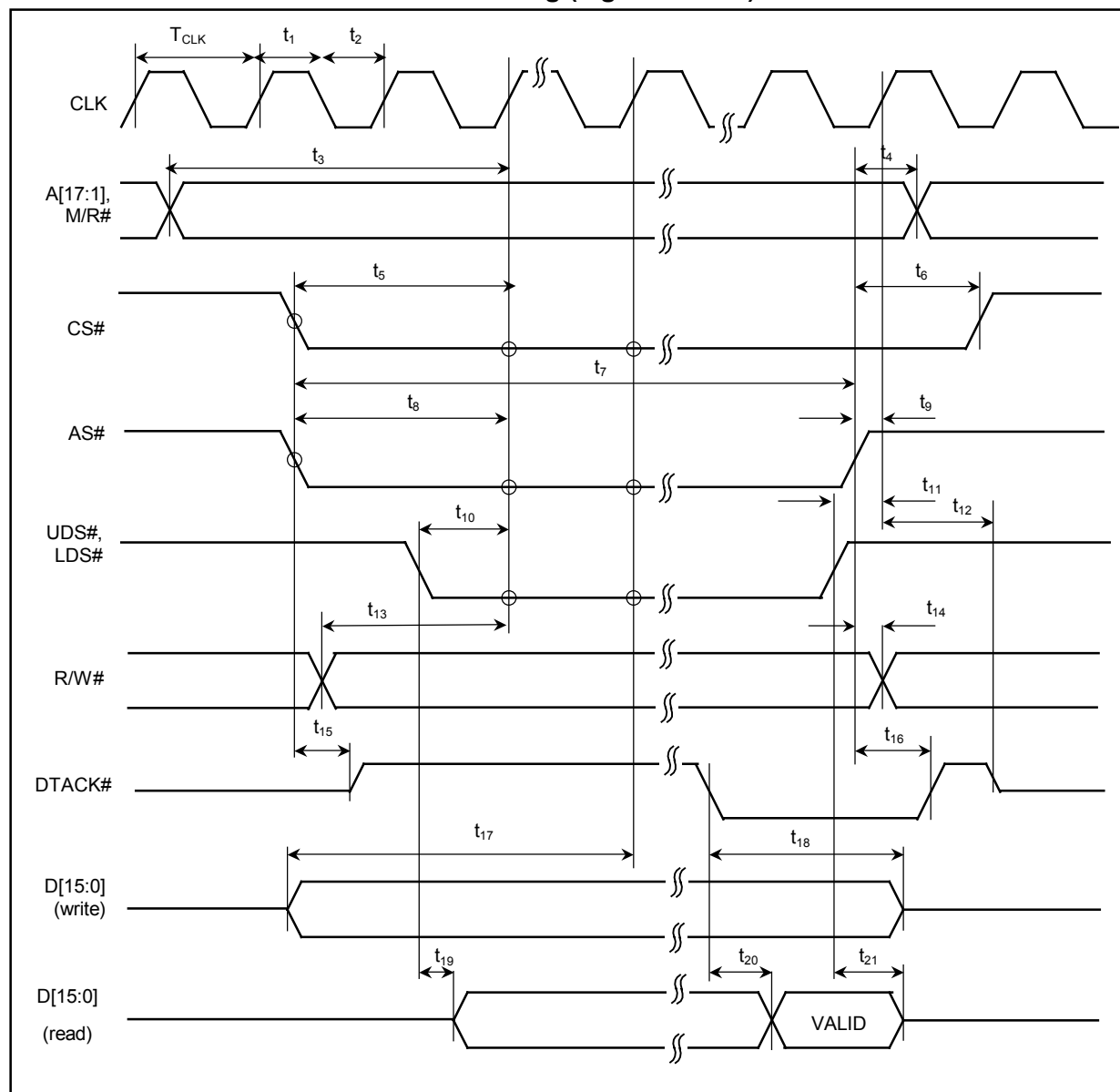

Figure 10-4 : Motorola MC68K #1 Interface Timing

**Table 10-6 : Motorola MC68K #1 Interface Timing**

Symbol	Parameter	Min	Max	Units
$f_{CLK}$	Bus Clock frequency		66	MHz
$T_{CLK}$	Bus Clock period	$1/f_{CLK}$		ns
$t_1$	Clock pulse width high	6		ns
$t_2$	Clock pulse width low	6		ns
$t_3$	A[17:1], M/R# setup to first CLK rising edge where CS# = 0, AS#=0,UDS#=0,and LDS#=0	1		ns
$t_4$	A[17:1], M/R# hold from AS# rising edge	0		ns
$t_5$	CS# setup to CLK rising edge while AS#, UDS#/LDS# = 0	1		ns
$t_6$	CS# hold from AS# rising edge	0		ns
$t_{7a}$	AS# asserted for MCLK = BCLK		13	$T_{CLK}$
$t_{7b}$	AS# asserted for MCLK = BCLK +2		18	$T_{CLK}$
$t_{7c}$	AS# asserted for MCLK = BCLK +3		23	$T_{CLK}$
$t_{7d}$	AS# asserted for MCLK = BCLK +4		28	$T_{CLK}$
$t_8$	AS# setup to CLK rising edge while CS#, AS#, UDS#/LDS# =0	1		ns
$t_9$	AS# setup to CLK rising edge	2		$T_{CLK}$
$t_{10}$	UDS#/LDS# setup to CLK rising edge while CS#, AS#, UDS#/LDS# = 0	1		ns
$t_{11}$	UDS#/LDS# high setup to CLK rising edge	2		ns
$t_{12}$	First CLK rising edge where AS#=1 to DTACK# high impedance	3	14	ns
$t_{13}$	R/W# setup to CLK rising edge before all CS#, AS#, UDS# and/or LDS# = 0	1		ns
$t_{14}$	R/W# hold from AS# rising edge	0		ns
$t_{15}$	AS# = 0 and CS# = 0 to DTACK# driven high	3	13	ns
$t_{16}$	AS# rising edge to DTACK# rising edge	4	16	ns
$t_{17}$	D[15:0] valid to third CLK rising edge where CS# = 0, AS# = 0 and either UDS# = 0 or LDS# = 0 (write cycle) (see note 1)	0		ns
$t_{18}$	D[15:0] hold from DTACK# falling edge (write cycle)	0		ns
$t_{19}$	UDS# = 0 and/or LDS# = 0 to D[15:0] driven (read cycle)	3	13	ns
$t_{20}$	DTACK# falling edge to D[15:0] valid (read cycle)		2	ns
$t_{21}$	UDS#, LDS# rising edge to D[15:0] high impedance (read cycle)	3	13	ns

1.  $t_{17}$  is the delay from when data is placed on the bus until the data is latched into the write buffer.

### 10.2.4 Motorola DragonBall Interface Timing with DTACK# (e.g. MC68EZ328/MC68VZ328)

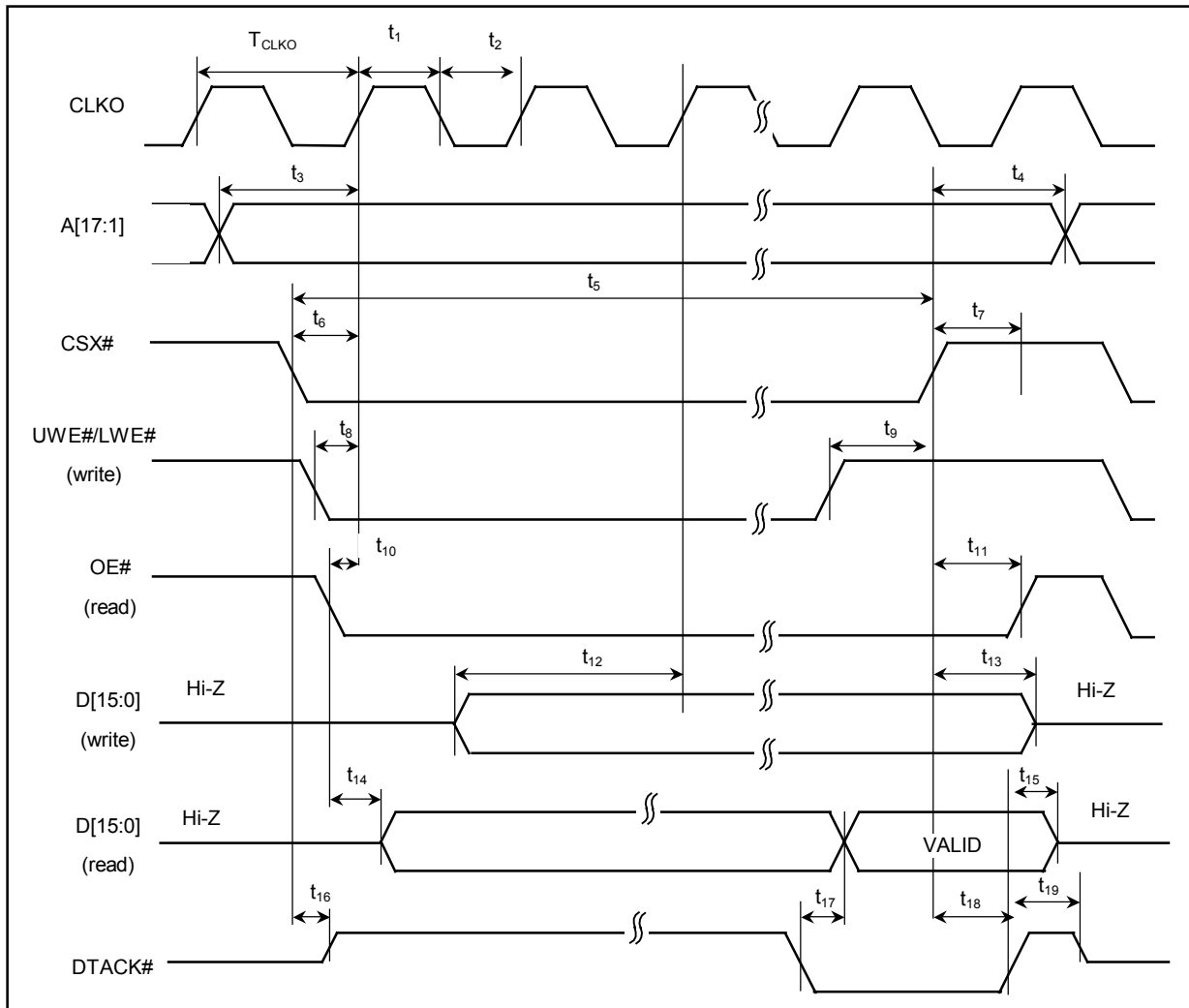

Figure 10-5 : Motorola DragonBall Interface with DTACK# Timing

**Table 10-7 : Motorola DragonBall Interface with DTACK# Timing**

Symbol	Parameter	MC68EZ328		MC68VZ328		Units
		Min	Max	Min	Max	
f <sub>CLKO</sub>	Bus Clock frequency		16		33	MHz
T <sub>CLKO</sub>	Bus Clock period	1/f <sub>CLKO</sub>		1/f <sub>CLKO</sub>		ns
t <sub>1</sub>	Clock pulse width high	28.1		13.5		ns
t <sub>2</sub>	Clock pulse width low	28.1		13.5		ns
t <sub>3</sub>	A[17:1] setup 1st CLKO when CSX# = 0 and either UWE#/LWE# or OE# = 0	0		0		ns
t <sub>4</sub>	A[17:1] hold from CSX# rising edge	0		0		ns
t <sub>5a</sub>	CSX# asserted for MCLK = BCLK		13		13	T <sub>CLKO</sub>
t <sub>5b</sub>	CSX# asserted for MCLK = BCLK +2		18		18	T <sub>CLKO</sub>
t <sub>5c</sub>	CSX# asserted for MCLK = BCLK +3		23		23	T <sub>CLKO</sub>
t <sub>5d</sub>	CSX# asserted for MCLK = BCLK +4		28		28	T <sub>CLKO</sub>
t <sub>6</sub>	CSX# setup to CLKO rising edge	0		0		ns
t <sub>7</sub>	CSX# rising edge to CLKO rising edge	0		0		ns
t <sub>8</sub>	UWE#/LWE# falling edge to CLKO rising edge	0		0		ns
t <sub>9</sub>	UWE#/LWE# rising edge to CSX# rising edge	0		0		ns
t <sub>10</sub>	OE# falling edge to CLKO rising edge	1		1		ns
t <sub>11</sub>	OE# hold from CSX# rising edge	0		0		ns
t <sub>12</sub>	D[15:0] setup to 3rd CLKO when CSX#, UWE#/LWE# asserted (write cycle) (see note 1)	0		0		ns
t <sub>13</sub>	D[15:0] in hold from CSX# rising edge(write cycle)	0		0		ns
t <sub>14</sub>	Falling edge of OE# to D[15:0] driven (read cycle)	3	15	3	15	ns
t <sub>15</sub>	CLKO rising edge to D[15:0] output Hi-Z (read cycle)	2	12	2	12	ns
t <sub>16</sub>	CSX# falling edge to DTACK# driven high	3	13	3	13	ns
t <sub>17</sub>	DTACK# falling edge to D[15:0]valid (read cycle)		2		2	ns
t <sub>18</sub>	CSX# high to DTACK# high	3	16	3	16	ns
t <sub>19</sub>	CLKO rising edge to DTACK# Hi-Z	1	6	1	6	ns

<sup>1</sup> t<sub>12</sub> is the delay from when data is placed on the bus until the data is latched into the write buffer.

**10.2.5 Motorola DragonBall Interface Timing without DTACK# (e.g. MC68EZ328/MC68VZ328)**

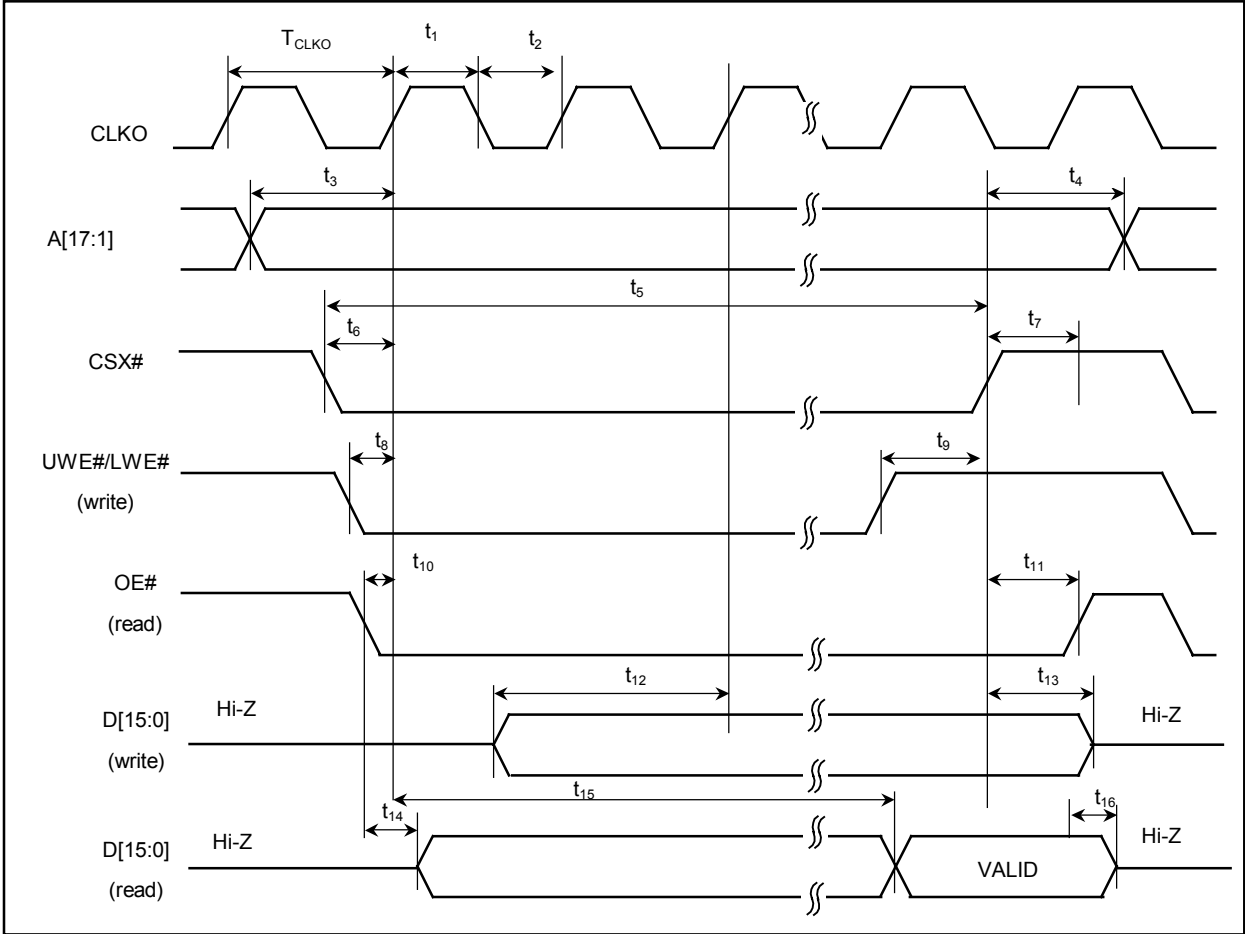

**Figure 10-6 : Motorola DragonBall Interface without DTACK# Timing**

**Table 10-8 : Motorola DragonBall Interface without DTACK# Timing**

Symbol	Parameter	MC68EZ328		MC68VZ328		Units
		Min	Max	Min	Max	
f <sub>CLKO</sub>	Bus Clock frequency		16		33	MHz
T <sub>CLKO</sub>	Bus Clock period	1/f <sub>CLKO</sub>		1/f <sub>CLKO</sub>		ns
t <sub>1</sub>	Clock pulse width high	28.1		13.6		ns
t <sub>2</sub>	Clock pulse width low	28.1		13.6		ns
t <sub>3</sub>	A[17:1] setup 1st CLKO when CSX# = 0 and either UWE#/LWE# or OE# = 0	0		0		ns
t <sub>4</sub>	A[16:1] hold from CSX# rising edge	0		0		ns
t <sub>5a</sub>	CSX# asserted for MCLK = BCLK		13		13	T <sub>CLKO</sub>
t <sub>5b</sub>	CSX# asserted for MCLK = BCLK ÷2		18		18	T <sub>CLKO</sub>
t <sub>5c</sub>	CSX# asserted for MCLK = BCLK ÷3		23		23	T <sub>CLKO</sub>
t <sub>5d</sub>	CSX# asserted for MCLK = BCLK ÷4		28		28	T <sub>CLKO</sub>
t <sub>6</sub>	CSX# setup to CLKO rising edge	0		0		ns
t <sub>7</sub>	CSX# rising edge to CLKO rising edge	0		0		ns
t <sub>8</sub>	UWE#/LWE# falling edge to CLKO rising edge	0		0		ns
t <sub>9</sub>	UWE#/LWE# rising edge to CSX# rising edge	0		0		ns
t <sub>10</sub>	OE# falling edge to CLKO rising edge	1		1		ns
t <sub>11</sub>	OE# hold from CSX# rising edge	0		0		ns
t <sub>12</sub>	D[15:0] setup to 3rd CLKO when CSX#, UWE#/LWE# asserted (write cycle) (see note 1)	0		0		ns
t <sub>13</sub>	D[15:0] hold from CSX# rising edge(write cycle)	0		0		ns
t <sub>14</sub>	Falling edge of OE# to D[15:0] driven (read cycle)	3	15	3	15	ns
t <sub>15a</sub>	1st CLKO rising edge after OE# and CSX# asserted low to D[15:0] valid for MCLK = BCLK (read cycle)		13		13	T <sub>CLKO</sub>
t <sub>15b</sub>	1st CLKO rising edge after OE# and CSX# asserted low to D[15:0] valid for MCLK = BCLK ÷2 (read cycle)		18		18	T <sub>CLKO</sub>
t <sub>15c</sub>	1st CLKO rising edge after OE# and CSX# asserted low to D[15:0] valid for MCLK = BCLK ÷3 (read cycle)		23		23	T <sub>CLKO</sub>
t <sub>15d</sub>	1st CLKO rising edge after OE# and CSX# asserted low to D[15:0] valid for MCLK = BCLK ÷4 (read cycle)		28		28	T <sub>CLKO</sub>
t <sub>16</sub>	CLKO rising edge to D[15:0] output Hi-Z (read cycle)	2	12	2	12	ns

**Note**

1 t<sub>12</sub> is the delay from when data is placed on the bus until the data is latched into the write buffer.



### 10.2.6 Hitachi SH-3 Interface Timing (e.g. SH7709A)

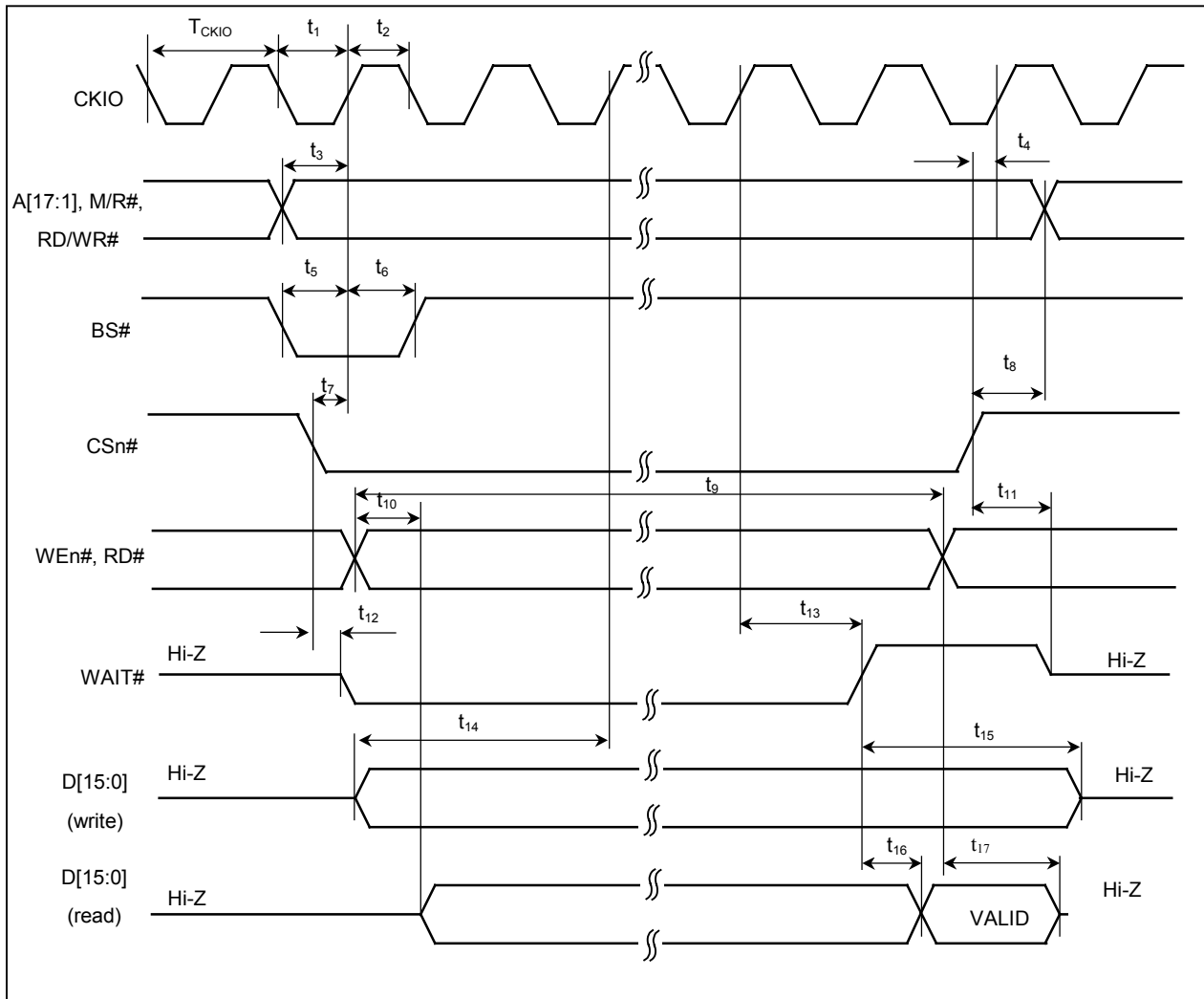

Figure 10-7 : Hitachi SH-3 Interface Timing

**Table 10-9 : Hitachi SH-3 Interface Timing**

Symbol	Parameter	Min	Max	Units
$f_{CKIO}$	Bus Clock frequency		66	MHZ
$T_{CKIO}$	Bus Clock period	$1/f_{CKIO}$		ns
$t_1$	Bus Clock pulse width low	9		ns
$t_2$	Bus Clock pulse width high	9		ns
$t_3$	A[17:1], M/R#, RD/WR# setup to CKIO	1		ns
$t_4$	CSn# high setup to CKIO	1		ns
$t_5$	BS# setup	1		ns
$t_6$	BS# hold	2		ns
$t_7$	CSn# setup	1		ns
$t_8$	A[17:1], M/R#, RD/WR# hold from CS#	0		ns
$t_{9a}$	RD# or WEn# asserted for MCLK = BCLK (max.MCLK=50MHz)		13	$T_{CKIO}$
$t_{9b}$	RD# or WEn# asserted for MCLK = BCLK $\div 2$		18	$T_{CKIO}$
$t_{9c}$	RD# or WEn# asserted for MCLK = BCLK $\div 3$		23	$T_{CKIO}$
$t_{9d}$	RD# or WEn# asserted for MCLK = BCLK $\div 4$		28	$T_{CKIO}$
$t_{10}$	Falling edge RD# to D[15:0] driven (read cycle)	3	12	ns
$t_{11}$	Rising edge CSn# to WAIT# high impedance	2	10	ns
$t_{12}$	Falling edge CSn# to WAIT# driven low	$3 T_{CKIO} + 2$	$3 T_{CKIO} + 12$	ns
$t_{13}$	CLIO to WAIT# delay	4	18	ns
$t_{14}$	D[15:0] setup to 2 <sup>nd</sup> CKIO after BS# (write cycle) (see note 1)	0		ns
$t_{15}$	D[15:0] hold (write cycle)	0		ns
$t_{16}$	WAIT# rising edge to D[15:0] valid (read cycle)		2	ns
$t_{17}$	Rising edge RD# to D[15:0] high impedance (read cycle)	3	12	ns

1.  $t_{14}$  is the delay from when data is placed on the bus until the data is latched into the write buffer.

**Note**

Minimum three software WAIT states are required.

10.2.7 Hitachi SH-4 Interface Timing (e.g. SH7751)

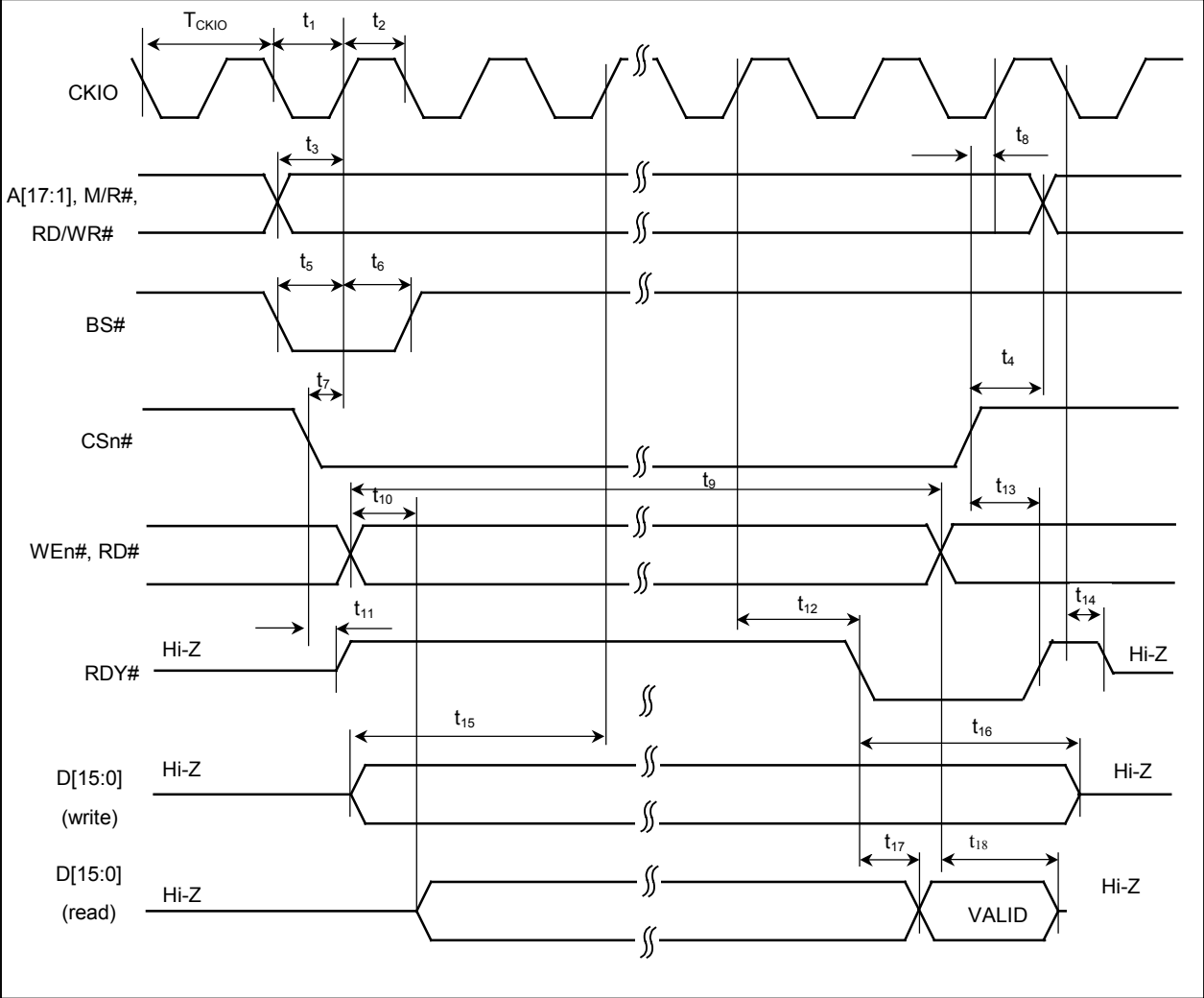

Figure 10-8 : Hitachi SH-4 Interface Timing

**Table 10-10 : Hitachi SH-4 Interface Timing**

Symbol	Parameter	Min	Max	Units
$f_{CKIO}$	Clock frequency		66	MHz
$T_{CKIO}$	Clock period	$1/f_{CKIO}$		ns
$t_1$	Clock pulse width low	6.8		ns
$t_2$	Clock pulse width high	6.8		ns
$t_3$	A[17:1], M/R#, RD/WR# setup to CKIO	1		ns
$t_4$	A[17:1], M/R#, RD/WR# hold from CSn#	0		ns
$t_5$	BS# setup	1		ns
$t_6$	BS# hold	2		ns
$t_7$	CSn# setup	1		ns
$t_8$	CSn# high setup to CKIO	2		ns
$t_{9a}$	RD# or WEn# asserted for MCLK = BCLK (max.MCLK=50MHz)		13	$T_{CKIO}$
$t_{9b}$	RD# or WEn# asserted for MCLK = BCLK $\pm 2$		18	$T_{CKIO}$
$t_{9c}$	RD# or WEn# asserted for MCLK = BCLK $\pm 3$		23	$T_{CKIO}$
$t_{9d}$	RD# or WEn# asserted for MCLK = BCLK $\pm 4$		28	$T_{CKIO}$
$t_{10}$	Falling edge RD# to D[15:0] driven (read cycle)	3	12	ns
$t_{11}$	Falling edge CSn# to RDY# driven high	$3 T_{CKIO} + 3$	$3 T_{CKIO} + 12$	ns
$t_{12}$	CKIO to RDY# low	4	18	ns
$t_{13}$	CSn# high to RDY# high	4	14	ns
$t_{14}$	Falling edge CKIO to RDY# high impedance	4	14	ns
$t_{15}$	D[15:0] setup to 2 <sup>nd</sup> CKIO after BS# (write cycle) (see note 1)	0		ns
$t_{16}$	D[15:0] hold (write cycle)	0		ns
$t_{17}$	RDY# falling edge to D[15:0] valid (read cycle)		2	ns
$t_{18}$	Rising edge RD# to D[15:0] high impedance (read cycle)	3	12	ns

1.  $t_{15}$  is the delay from when data is placed on the bus until the data is latched into the write buffer.

**Note**

Minimum three software WAIT states are required.

## 10.3 LCD Power Sequencing

### 10.3.1 Passive/TFT Power-On Sequence

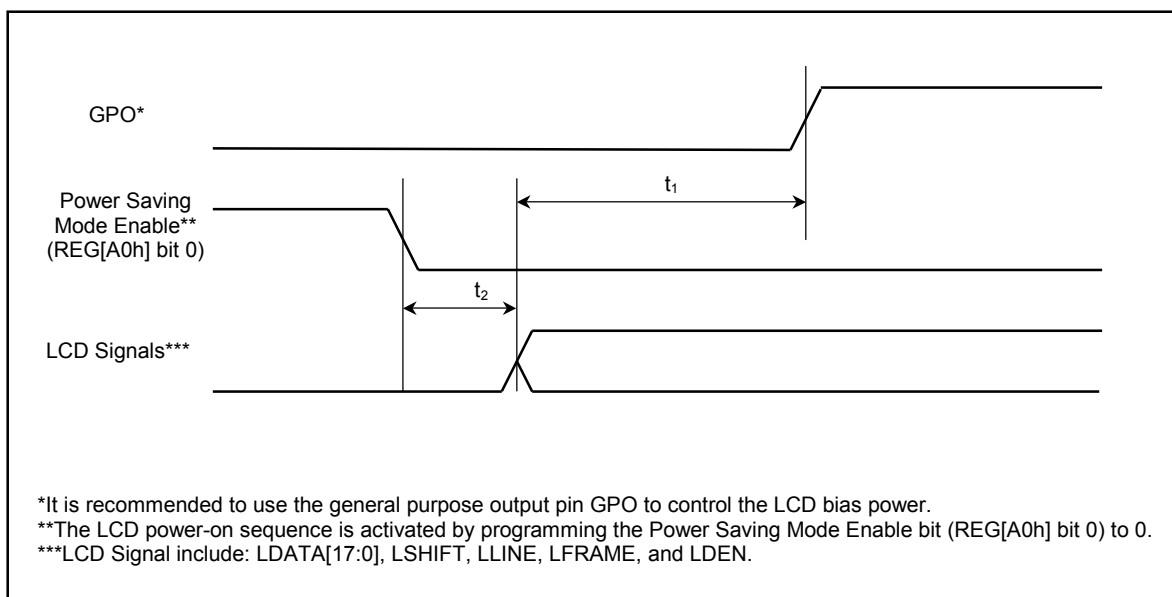

**Figure 10-9 : Passive/TFT Power-On Sequence Timing**

**Table 10-11 : Passive/TFT Power-On Sequence Timing**

Symbol	Parameter	Min	Max	Units
$t_1$	LCD signals active to LCD bias active	Note 1	Note 1	
$t_2$	Power Saving Mode disabled to LCD signals active	0	20	ns

1.  $t_1$  is controlled by software and must be determined from the bias power supply delay requirements of the panel connected.

#### Note

For HR-TFT Power-On/Off sequence information, see referenced document of Sharp HR-TFT Panels.

### 10.3.2 Passive/TFT Power-Off Sequence

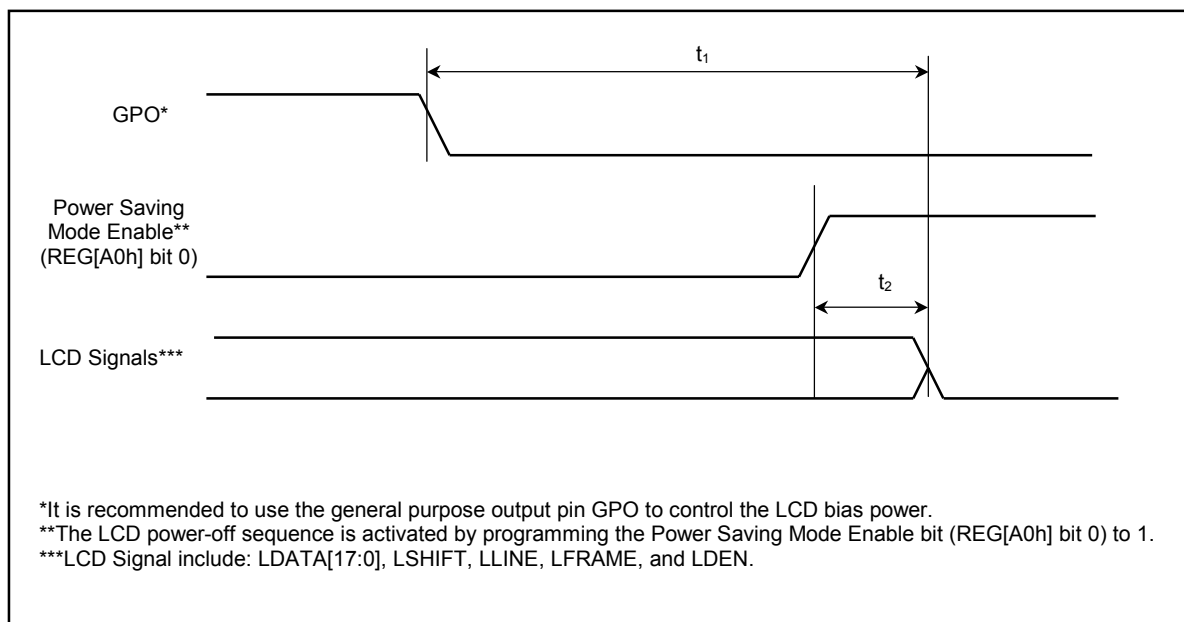

**Figure 10-10 : Passive/TFT Power-Off Sequence Timing**

**Table 10-12 : Passive/TFT Power-Off Sequence Timing**

Symbol	Parameter	Min	Max	Units
t <sub>1</sub>	LCD bias deactivated active to LCD signals inactive	Note 1	Note 1	
t <sub>2</sub>	Power Saving Mode disabled to LCD signals low	0	20	ns

1. t<sub>1</sub> is controlled by software and must be determined from the bias power supply delay requirements of the panel connected.

### 10.3.3 Power Saving Status

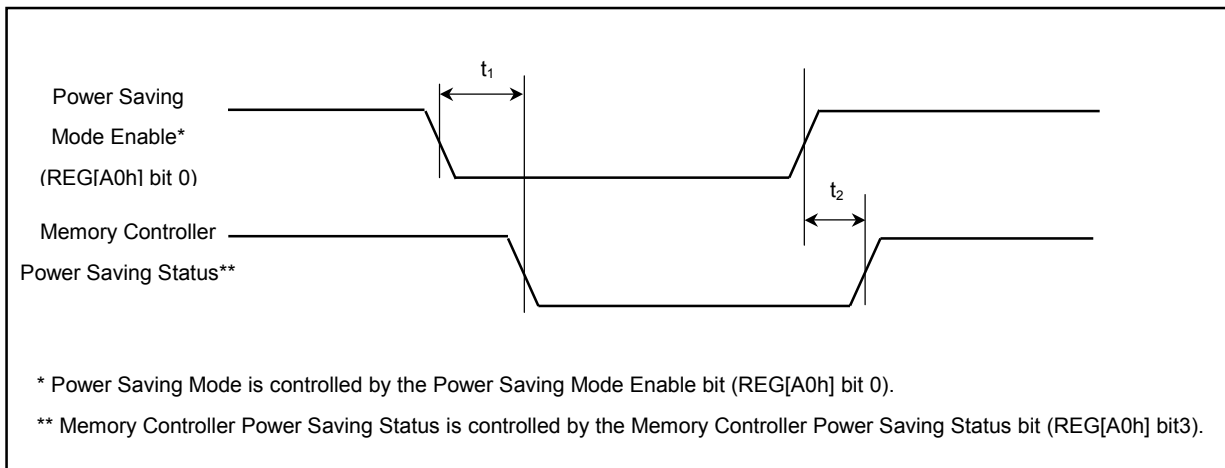

**Figure 10-11 : Power Saving Status Timing**

**Table 10-13 : Power Saving Status Timing**

Symbol	Parameter	Min	Max	Units
$t_1$	Power Saving Mode disabled to Memory Controller Power Saving Status low	Note 1	Note 1	ns
$t_2$	Power Saving Mode enabled to Memory Controller Power Saving Status high	0	20	MCLK (note 1)

1. For further information on the internal clock MCLK, see Section 11.1.2, "MCLK".

## 10.4 Display Interface

Figure 10-12 : Panel Timing Parameters shows the timing parameters required to drive a flat panel display. Timing details for each supported panel types are provided in the remainder of this section.

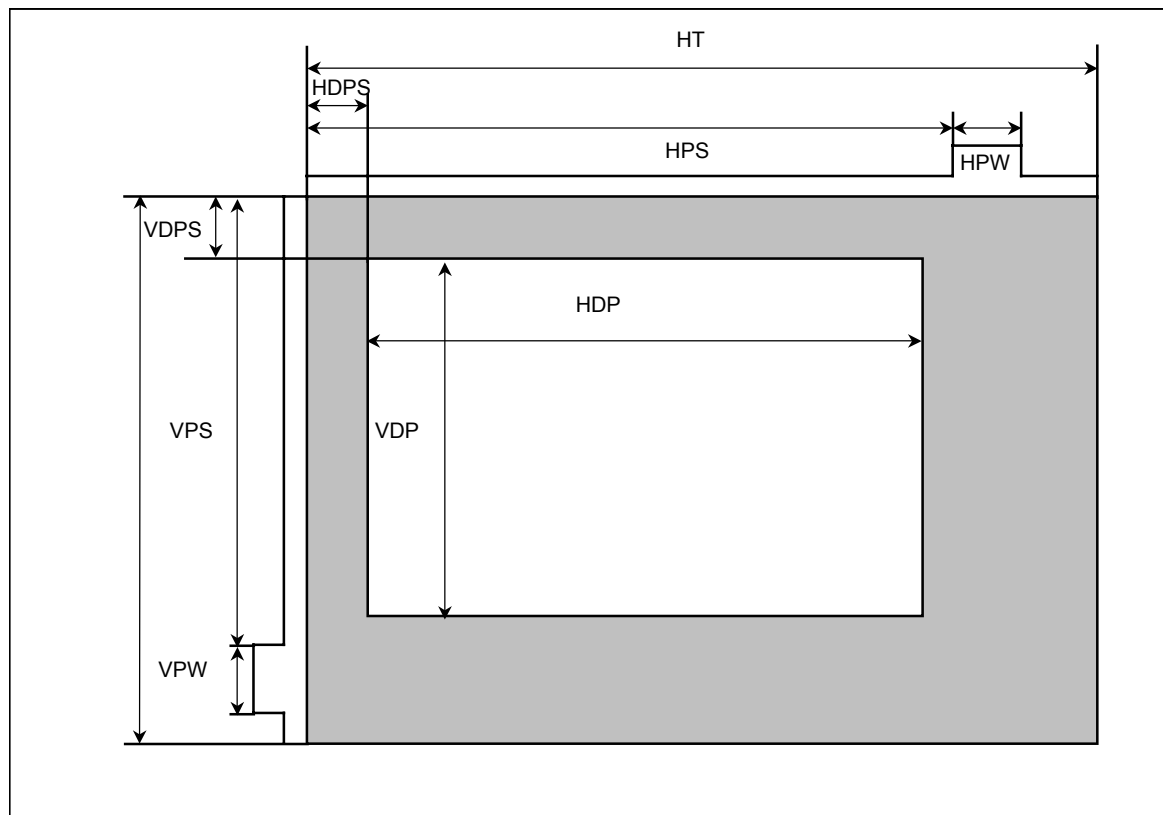

Figure 10-12 : Panel Timing Parameters

Table 10-14 : Panel Timing Parameter Definition and Register Summary

Symbol	Description	Derived From	Units
HT	Horizontal Total	$((\text{REG}[12\text{h}] \text{ bits } 6-0) + 1) \times 8$	Ts <sup>1</sup>
HDP <sup>2</sup>	Horizontal Display Period <sup>2</sup>	$((\text{REG}[14\text{h}] \text{ bits } 6-0) + 1) \times 8$	
HDPS <sup>3</sup>	Horizontal Display Period Start Position <sup>3</sup>	$((\text{REG}[17\text{h}] \text{ bits } 1-0, \text{REG}[16\text{h}] \text{ bits } 7-0) + \text{Offset}^5)$	
HPS	LLINE Pulse Start Position	$(\text{REG}[23\text{h}] \text{ bits } 1-0, \text{REG}[22\text{h}] \text{ bits } 7-0) + 1$	
HPW	LLINE Pulse Width	$(\text{REG}[20\text{h}] \text{ bits } 6-0) + 1$	
VT	Vertical Total	$((\text{REG}[19\text{h}] \text{ bits } 1-0, \text{REG}[18\text{h}] \text{ bits } 7-0) + 1) \times \text{HT}$	Ts <sup>1</sup>
VDP <sup>4</sup>	Vertical Display Period <sup>4</sup>	$((\text{REG}[1\text{Dh}] \text{ bits } 1-0, \text{REG}[1\text{Ch}] \text{ bits } 7-0) + 1) \times \text{HT}$	
VDPS	Vertical Display Period Start Position	$(\text{REG}[1\text{Fh}] \text{ bits } 1-0, \text{REG}[1\text{Eh}] \text{ bits } 7-0) \times \text{HT}$	
VPS	LFRAME Pulse Start Position	$(\text{REG}[27\text{h}] \text{ bits } 1-0, \text{REG}[26\text{h}] \text{ bits } 7-0) \times \text{HT} + (\text{REG}[31\text{h}] \text{ bits } 1-0, \text{REG}[30\text{h}] \text{ bits } 7-0)$	
VPW	LFRAME Pulse Width	$((\text{REG}[24\text{h}] \text{ bits } 2-0) + 1) \times \text{HT} + (\text{REG}[35\text{h}] \text{ bits } 1-0, \text{REG}[34\text{h}] \text{ bits } 7-0) - (\text{REG}[31\text{h}] \text{ bits } 1-0, \text{REG}[30\text{h}] \text{ bits } 7-0)$	

The following conditions must be fulfilled for all panel timings:



- 1  $HDPS + HDP < HT$
- 2  $VDPS + VDP < VT$
- 3  $T_s$  = pixel clock period
- 4 The HDP must be a minimum of 32 pixels and can be increased by multiples of 8.
- 5 The HDPS parameter contains an offset that depends on the panel type. This offset is the constant in the equation to describes parameter  $t_{14\text{ min}}$  in the AC Timing tables for the various panel types.
- 6 The VDP must be a minimum of 2 lines.
- 7 Offset for STN and CSTN panel = 22, offset for TFT panel = 5.

### 10.4.1 Generic STN Panel Timing

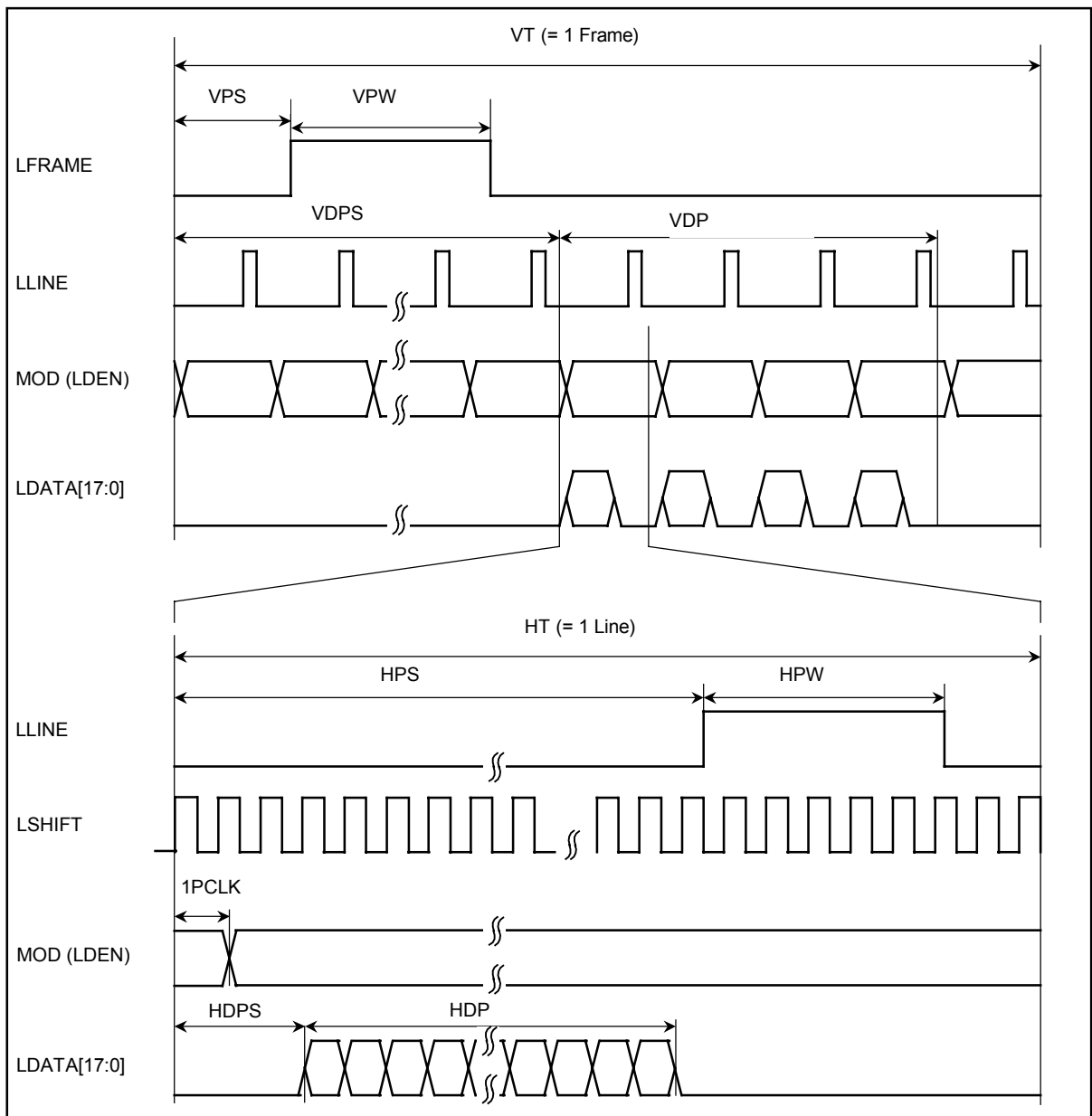
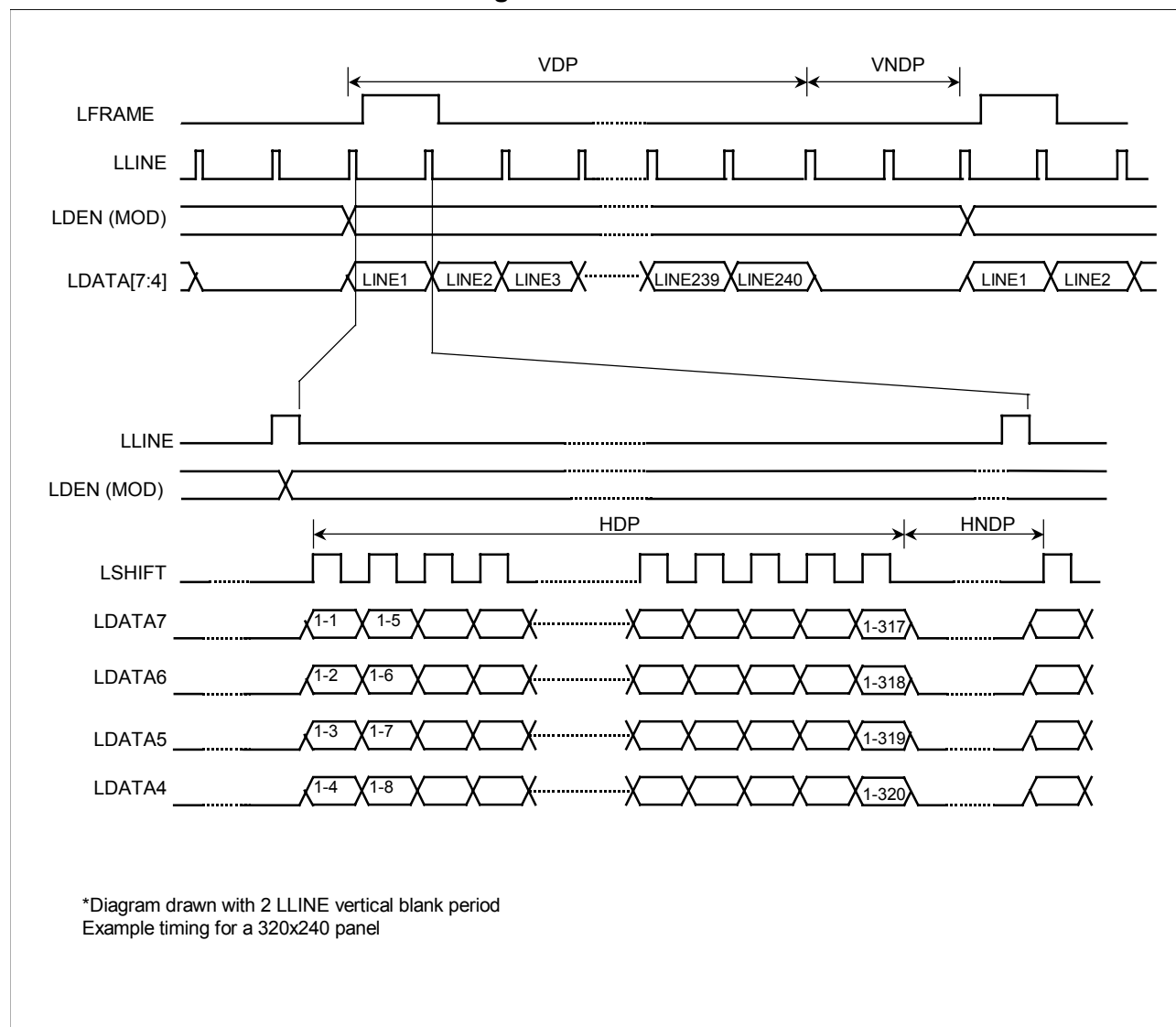

Figure 10-13 : Generic STN Panel Timing

VT = Vertical Total  
 =  $[(\text{REG}[19\text{h}]\text{bits}1-0, \text{REG}[18\text{h}]\text{bits}7-0) + 1]$  lines  
 VPS = LFRAME Pulse Start Position  
 =  $[(\text{REG}[27\text{h}]\text{ bits } 1-0, \text{REG}[26\text{h}]\text{ bits } 7-0)] \times \text{HT} + (\text{REG}[31\text{h}]\text{ bits } 1-0, \text{REG}[30\text{h}]\text{ bits } 7-0)$  pixels  
 VPW = LFRAME Pulse Width  
 =  $[(\text{REG}[24\text{h}]\text{ bits } 2-0) + 1] \times \text{HT} + (\text{REG}[35\text{h}]\text{ bits } 1-0, \text{REG}[34\text{h}]\text{ bits } 7-0) - (\text{REG}[31\text{h}]\text{ bits } 1-0, \text{REG}[30\text{h}]\text{ bits } 7-0)$  pixels  
 VDPS = Vertical Display Period Start Position  
 =  $[(\text{REG}[1\text{Fh}]\text{bits}1-0, \text{REG}[1\text{Eh}]\text{bits}7-0)]$  lines  
 VDP = Vertical Display Period  
 =  $[(\text{REG}[1\text{Dh}]\text{ bits } 1-0, \text{REG}[1\text{Ch}]\text{ bits } 7-0) + 1]$  lines  
 \* The VDP must be a minimum of 2 lines  
 HT = Horizontal Total  
 =  $[((\text{REG}[12\text{h}]\text{ bits } 6-0) + 1) \times 8]$  pixels  
 HPS = LLINE Pulse Start Position  
 =  $[(\text{REG}[23\text{h}]\text{ bits } 1-0, \text{REG}[22\text{h}]\text{ bits } 7-0) + 1]$  pixels  
 HPW = LLINE Pulse Width  
 =  $[(\text{REG}[20\text{h}]\text{ bits } 6-0) + 1]$  pixels  
 HDPS = Horizontal Display Period Start Position  
 =  $[(\text{REG}[17\text{h}]\text{bits}1-0, \text{REG}[16\text{h}]\text{bits}7-0) + 22]$  pixels  
 HDP = Horizontal Display Period  
 =  $[((\text{REG}[14\text{h}]\text{ bits } 6-0) + 1) \times 8]$  pixels  
 \* The HDP must be a minimum of 32 pixels and can be increased by multiples of 8.

\*Panel Type Bits (REG[10h] bits 2-0) = 000b (STN)  
 \*LFRAME Pulse Polarity Bit (REG[24h] bit 7) = 1 (active high)  
 \*LLINE Polarity Bit (REG[20h] bit 7) = 1 (active high).

## 10.4.2 Monochrome 4-Bit Panel Timing



**Figure 10-14 : Monochrome 4-Bit Panel Timing**

- VDP = Vertical Display Period  
= (REG[1Dh] bits 1:0, REG[1Ch] bits 7:0) + 1 Lines
- VNDP = Vertical Non-Display Period  
= VT - VDP  
= (REG[19h] bits 1:0, REG[18h] bits 7:0) - (REG[1Dh] bits 1:0, REG[1Ch] bits 7:0) Lines
- HDP = Horizontal Display Period  
= ((REG[14h] bits 6:0) + 1) x 8Ts
- HNDP = Horizontal Non-Display Period  
= HT - HDP  
= (((REG[12h] bits 6:0) + 1) x 8Ts) - (((REG[14h] bits 6:0) + 1) x 8Ts)

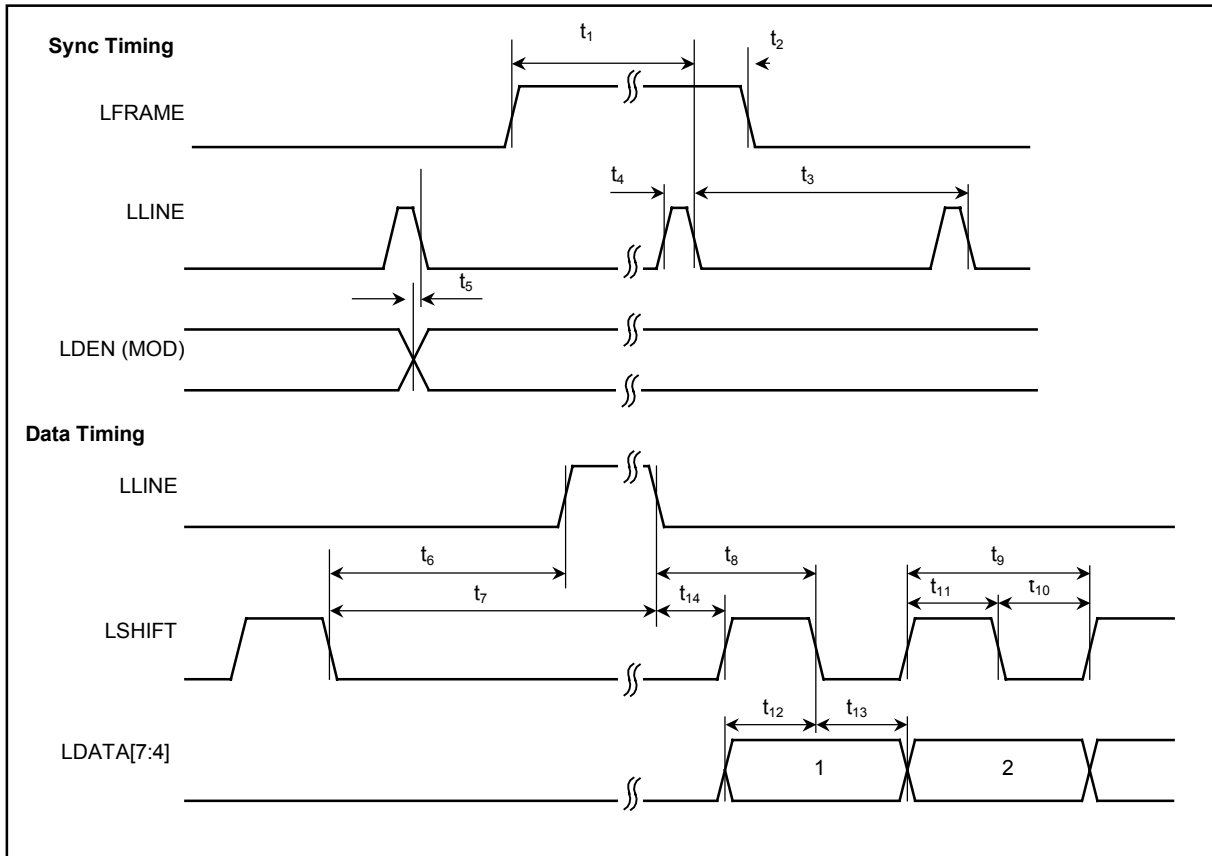

Figure 10-15 : Monochrome 4-Bit Panel A.C. Timing

**Table 10-15 : Monochrome 4-Bit Panel A.C. Timing**

Symbol	Parameter	Min	Typ	Max	Units
t <sub>1</sub>	LFRAME setup to LLINE falling edge	note 2			Ts (note 1)
t <sub>2</sub>	LFRAME hold from LLINE falling edge	note 3			Ts
t <sub>3</sub>	LLINE period	note 4			Ts
t <sub>4</sub>	LLINE pulse width	note 5			Ts
t <sub>5</sub>	MOD transition to LLINE falling edge	note 6			Ts
t <sub>6</sub>	LSHIFT falling edge to LLINE rising edge	note 7			Ts
t <sub>7</sub>	LSHIFT falling edge to LLINE falling edge	t <sub>6</sub> + t <sub>4</sub>			Ts
t <sub>8</sub>	LLINE falling edge to LSHIFT falling edge	t <sub>14</sub> + 2			Ts
t <sub>9</sub>	LSHIFT period	4			Ts
t <sub>10</sub>	LSHIFT pulse width low	2			Ts
t <sub>11</sub>	LSHIFT pulse width high	2			Ts
t <sub>12</sub>	LDATA[7:4] setup to LSHIFT falling edge	2			Ts
t <sub>13</sub>	LDATA[7:4] hold from LSHIFT falling edge	2			Ts
t <sub>14</sub>	LLINE falling edge to LSHIFT rising edge	note 8			Ts

1. Ts = pixel clock period
2. t<sub>1</sub> min = (HPS+ HPW) – (REG[31h] bits 1-0, REG[30h] bits 7-0)
3. t<sub>2</sub> min = VPW - t<sub>1</sub> min
4. t<sub>3</sub> min = HT
5. t<sub>4</sub> min = HPW
6. t<sub>5</sub> min = HT - HPS
7. t<sub>6</sub> min = HPS - (HDP + HDPS - 2)      if negative add t<sub>3</sub> min
8. t<sub>14</sub> min = HDPS - (HPS + t<sub>4</sub> min)      if negative add t<sub>3</sub> min

### 10.4.3 Monochrome 8-Bit Panel Timing

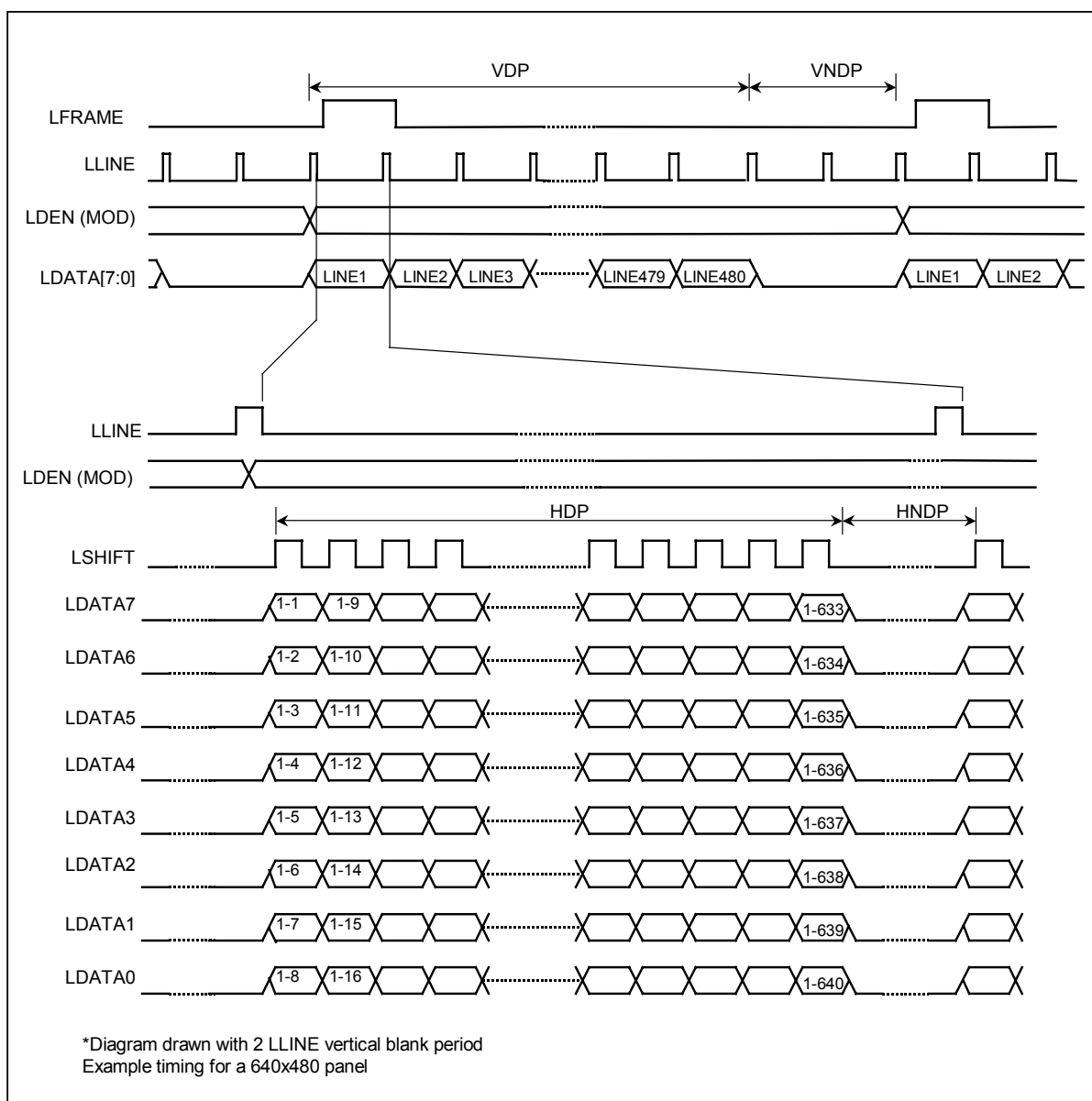

**Figure 10-16 : Monochrome 8-Bit Panel Timing**

- VDP = Vertical Display Period  
= (REG[1Dh] bits 1:0, REG[1Ch] bits 7:0) + 1 Lines
- VNDP = Vertical Non-Display Period  
= VT-VDP  
= (REG[19h] bits 1:0, REG[18h] bits 7:0) - (REG[1Dh] bits 1:0, REG[1Ch] bits 7:0) Lines
- HDP = Horizontal Display Period  
= ((REG[14h] bits 6:0) + 1) x 8Ts
- HNDP = Horizontal Non-Display Period  
= HT - HDP  
= (((REG[12h] bits 6:0) + 1) x 8Ts) - (((REG[14h] bits 6:0) + 1) x 8Ts)

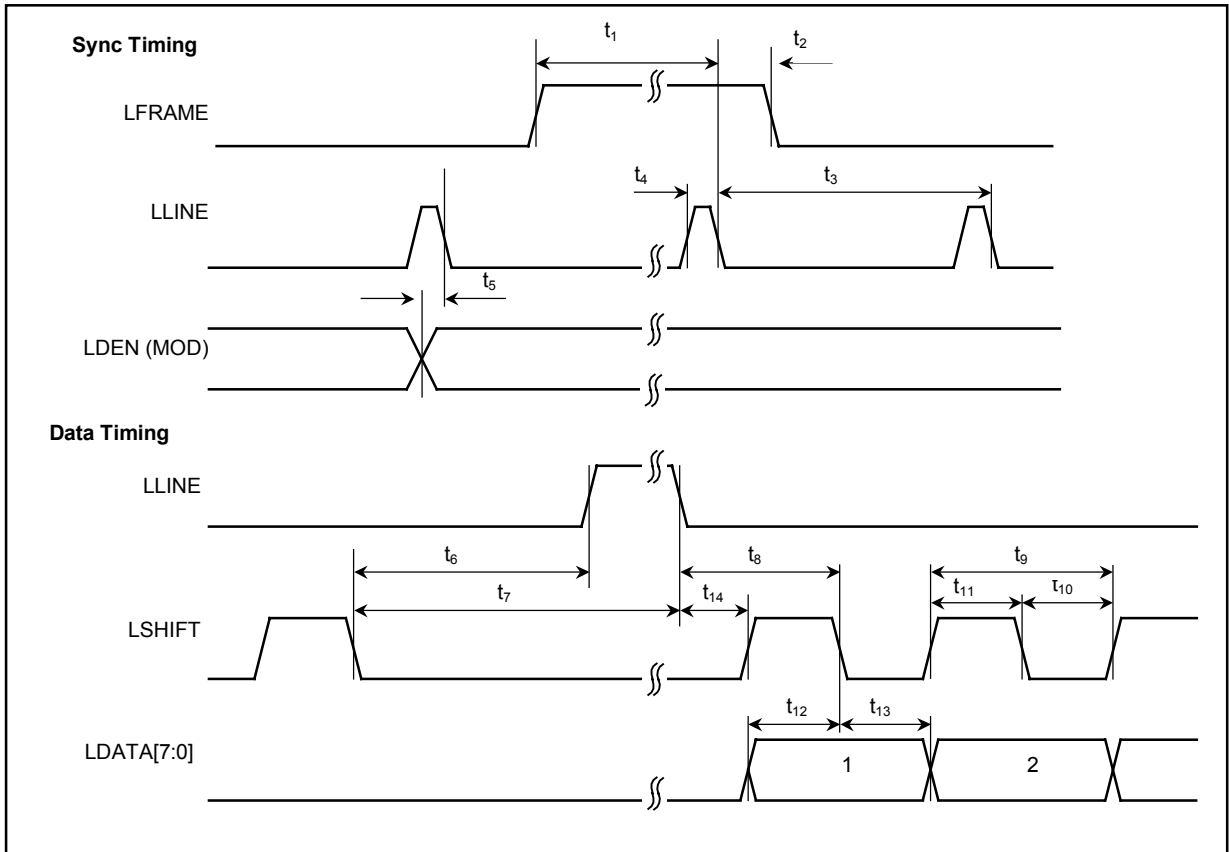

Figure 10-17 : Monochrome 8-Bit Panel A.C. Timing

**Table 10-16 : Monochrome 8-Bit Panel A.C. Timing**

Symbol	Parameter	Min	Typ	Max	Units
t <sub>1</sub>	LFRAME setup to LLINE falling edge	note 2			Ts (note 1)
t <sub>2</sub>	LFRAME hold from LLINE falling edge	note 3			Ts
t <sub>3</sub>	LLINE period	note 4			Ts
t <sub>4</sub>	LLINE pulse width	note 5			Ts
t <sub>5</sub>	MOD transition to LLINE falling edge	note 6			Ts
t <sub>6</sub>	LSHIFT falling edge to LLINE rising edge	note 7			Ts
t <sub>7</sub>	LSHIFT falling edge to LLINE falling edge	t <sub>6</sub> + t <sub>4</sub>			Ts
t <sub>8</sub>	LLINE falling edge to LSHIFT falling edge	t <sub>14</sub> + 4			Ts
t <sub>9</sub>	LSHIFT period	8			Ts
t <sub>10</sub>	LSHIFT pulse width low	4			Ts
t <sub>11</sub>	LSHIFT pulse width high	4			Ts
t <sub>12</sub>	LDATA[7:0] setup to LSHIFT falling edge	4			Ts
t <sub>13</sub>	LDATA[7:0] hold from LSHIFT falling edge	4			Ts
t <sub>14</sub>	LLINE falling edge to LSHIFT rising edge	note 8			Ts

1. Ts = pixel clock period
2. t<sub>1</sub> min = (HPS+ HPW) – (REG[31h] bits 1-0, REG[30h] bits 7-0)
3. t<sub>2</sub> min = VPW - t<sub>1</sub> min
4. t<sub>3</sub> min = HT
5. t<sub>4</sub> min = HPW
6. t<sub>5</sub> min = HT - HPS
7. t<sub>6</sub> min = HPS - (HDP + HDPS - 4)      if negative add t<sub>3</sub> min
8. t<sub>14</sub> min = HDPS - (HPS + t<sub>4</sub> min)      if negative add t<sub>3</sub> min



### 10.4.4 Color 4-Bit Panel Timing

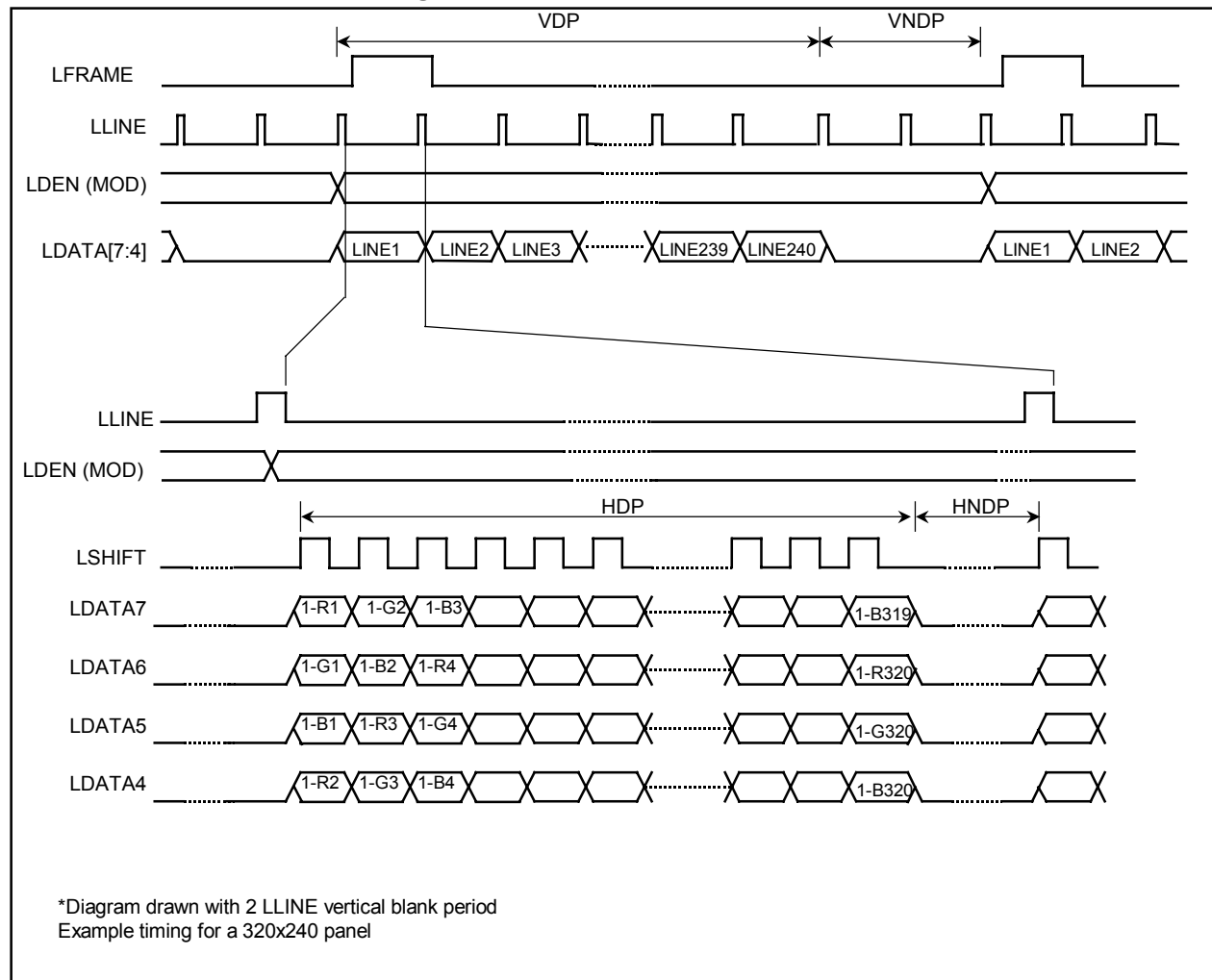

**Figure 10-18 : Color 4-Bit Panel Timing**

- VDP = Vertical Display Period  
= (REG[1Dh] bits 1:0, REG[1Ch] bits 7:0) + 1 Lines
- VNDP = Vertical Non-Display Period  
= VT-VDP  
= (REG[19h] bits 1:0, REG[18h] bits 7:0) - (REG[1Dh] bits 1:0, REG[1Ch] bits 7:0) Lines
- HDP = Horizontal Display Period  
= ((REG[14h] bits 6:0) + 1) x 8Ts
- HNDP = Horizontal Non-Display Period  
= HT - HDP  
= (((REG[12h] bits 6:0) + 1) x 8Ts) - (((REG[14h] bits 6:0) + 1) x 8Ts)

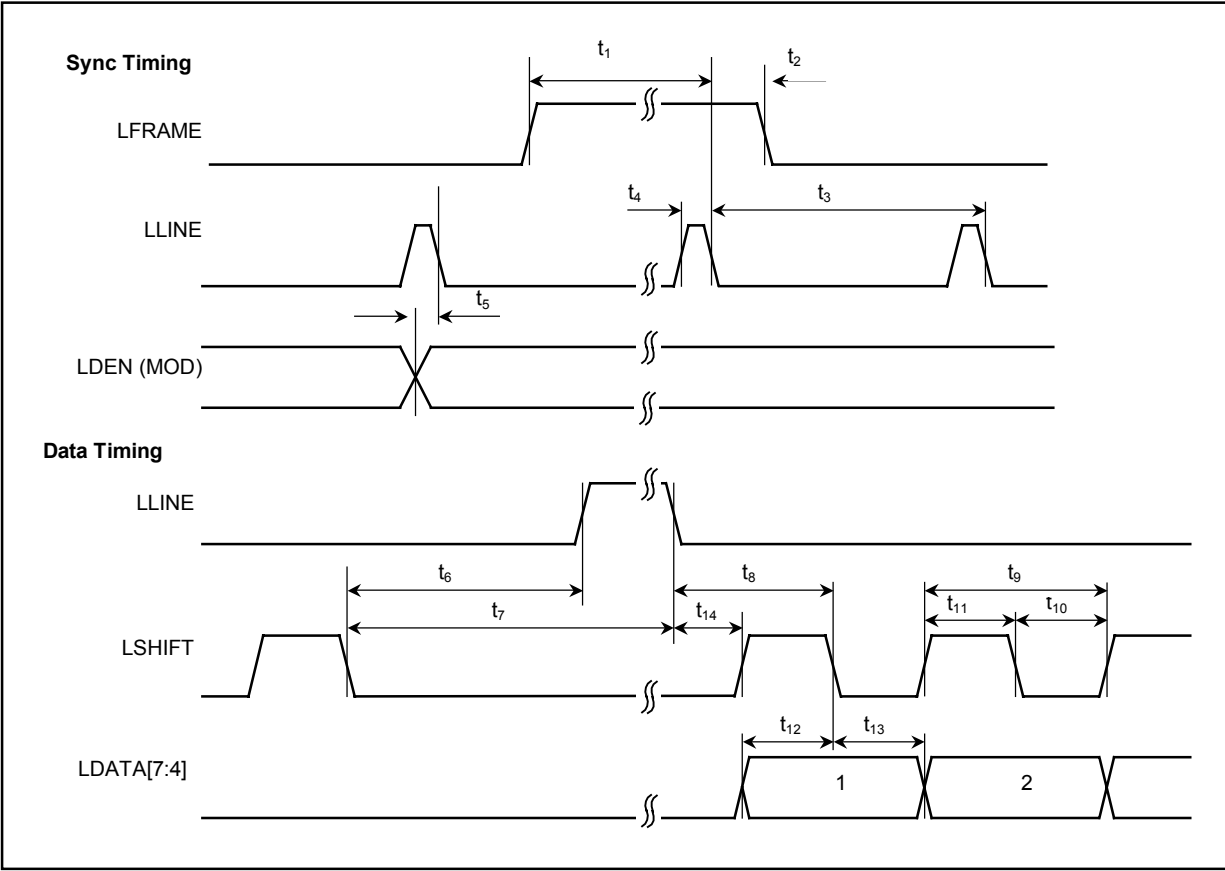

Figure 10-19 : Color 4-Bit Panel A.C. Timing

**Table 10-17 : Color 4-Bit Panel A.C. Timing**

Symbol	Parameter	Min	Typ	Max	Units
t <sub>1</sub>	LFRAME setup to LLINE falling edge	note 2			Ts (note 1)
t <sub>2</sub>	LFRAME hold from LLINE falling edge	note 3			Ts
t <sub>3</sub>	LLINE period	note 4			Ts
t <sub>4</sub>	LLINE pulse width	note 5			Ts
t <sub>5</sub>	MOD transition to LLINE falling edge	note 6			Ts
t <sub>6</sub>	LSHIFT falling edge to LLINE rising edge	note 7			Ts
t <sub>7</sub>	LSHIFT falling edge to LLINE falling edge	t <sub>6</sub> + t <sub>4</sub>			Ts
t <sub>8</sub>	LLINE falling edge to LSHIFT falling edge	t <sub>14</sub> + 0.5			Ts
t <sub>9</sub>	LSHIFT period	2			Ts
t <sub>10</sub>	LSHIFT pulse width low	1			Ts
t <sub>11</sub>	LSHIFT pulse width high	1			Ts
t <sub>12</sub>	LDATA[7:4] setup to LSHIFT falling edge	1			Ts
t <sub>13</sub>	LDATA[7:4] hold from LSHIFT falling edge	1			Ts
t <sub>14</sub>	LLINE falling edge to LSHIFT rising edge	note 8			Ts

1. Ts = pixel clock period
2. t<sub>1</sub> min = (HPS + HPW) – (REG[31h] bits 1-0, REG[30h] bits 7-0)
3. t<sub>2</sub> min = VPW - t<sub>1</sub> min
4. t<sub>3</sub> min = HT
5. t<sub>4</sub> min = HPW
6. t<sub>5</sub> min = HT - HPS
7. t<sub>6</sub> min = HPS - (HDP + HDPS - 3) if negative add t<sub>3</sub> min
8. t<sub>14</sub> min = HDPS - (HPS + t<sub>4</sub> min) + 1 if negative add t<sub>3</sub> min

### 10.4.5 Color 8-Bit Panel Timing (Format stripe)

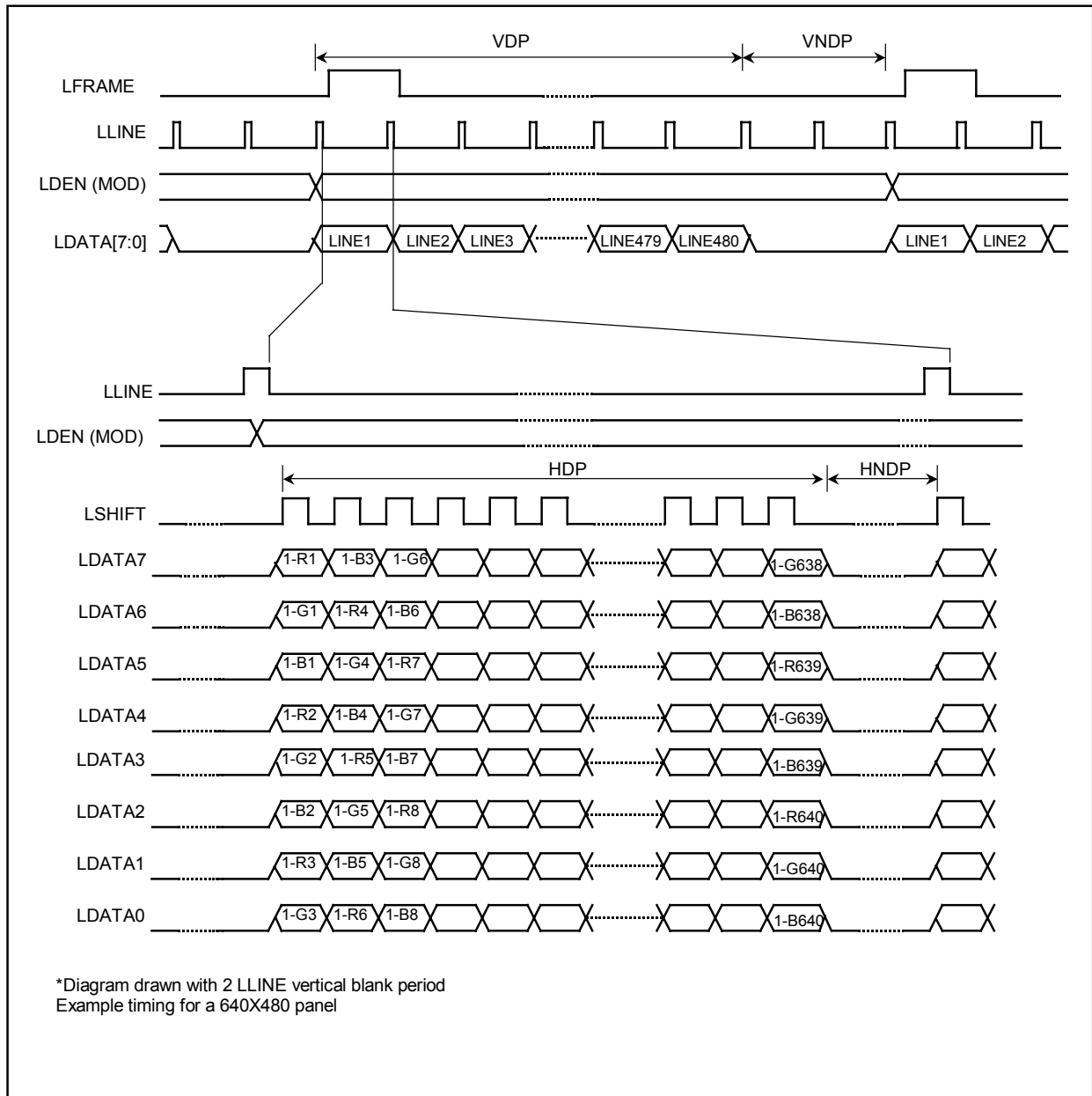
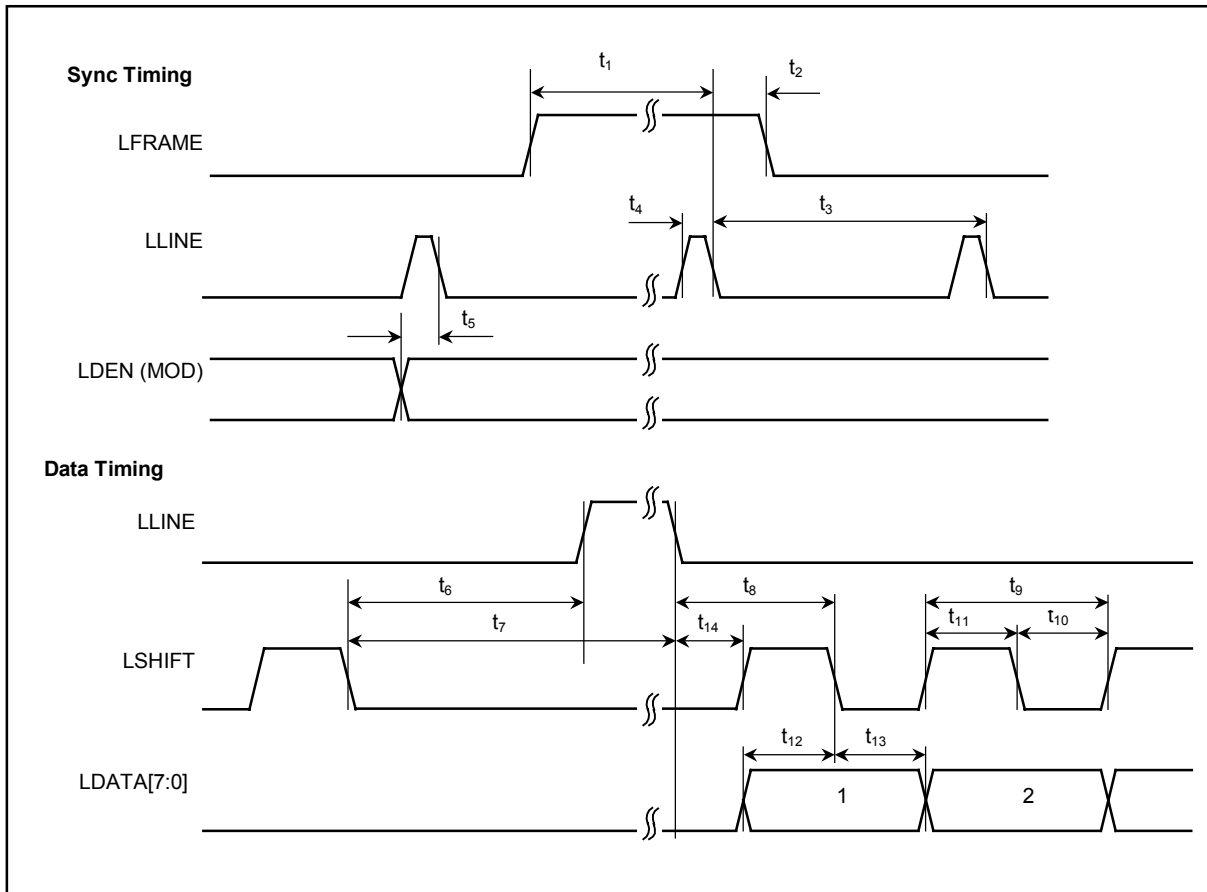

Figure 10-20 : Color 8-Bit Panel Timing (Format stripe)

**VDP** = Vertical Display Period  
 = (REG[1Dh] bits 1:0, REG[1Ch] bits 7:0) + 1 Lines  
**VNDP** = Vertical Non-Display Period  
 = VT-VDP  
 = (REG[19h] bits 1:0, REG[18h] bits 7:0) - (REG[1Dh] bits 1:0, REG[1Ch] bits 7:0) Lines  
**HDP** = Horizontal Display Period  
 = ((REG[14h] bits 6:0) + 1) x 8Ts  
**HNDP** = Horizontal Non-Display Period  
 = HT - HDP  
 = (((REG[12h] bits 6:0) + 1) x 8Ts) - (((REG[14h] bits 6:0) + 1) x 8Ts)



**Figure 10-21 : Color 8-Bit Panel A.C. Timing (Format stripe)**

**Table 10-18 : Color 8-Bit Panel A.C. Timing (Format stripe)**

Symbol	Parameter	Min	Typ	Max	Units
t <sub>1</sub>	LFRAME setup to LLINE falling edge	note 2			Ts (note 1)
t <sub>2</sub>	LFRAME hold from LLINE falling edge	note 3			Ts
t <sub>3</sub>	LLINE period	note 4			Ts
t <sub>4</sub>	LLINE pulse width	note 5			Ts
t <sub>5</sub>	MOD transition to LLINE falling edge	note 6			Ts
t <sub>6</sub>	LSHIFT falling edge to LLINE rising edge	note 7			Ts
t <sub>7</sub>	LSHIFT falling edge to LLINE falling edge	t <sub>6</sub> + t <sub>4</sub>			Ts
t <sub>8</sub>	LLINE falling edge to LSHIFT falling edge	t <sub>14</sub> + 2			Ts
t <sub>9</sub>	LSHIFT period	2			Ts
t <sub>10</sub>	LSHIFT pulse width low	1			Ts
t <sub>11</sub>	LSHIFT pulse width high	1			Ts
t <sub>12</sub>	LDATA[7:0] setup to LSHIFT falling edge	1			Ts
t <sub>13</sub>	LDATA[7:0] hold to LSHIFT falling edge	1			Ts
t <sub>14</sub>	LLINE falling edge to LSHIFT rising edge	note 8			Ts

1. Ts = pixel clock period
2. t<sub>1</sub> min = (HPS+ HPW) – (REG[31h] bits 1-0, REG[30h] bits 7-0)
3. t<sub>2</sub> min = VPW - t<sub>1</sub> min
4. t<sub>3</sub> min = HT
5. t<sub>4</sub> min = HPW
6. t<sub>5</sub> min = t<sub>3</sub> min -HPS
7. t<sub>6</sub> min = HPS - (HDP + HDPS - 1)      if negative add t<sub>3</sub> min
8. t<sub>14</sub> min = HDPS - (HPS + t<sub>4</sub> min)      if negative add t<sub>3</sub> min

## 10.4.6 Generic TFT Panel Timing

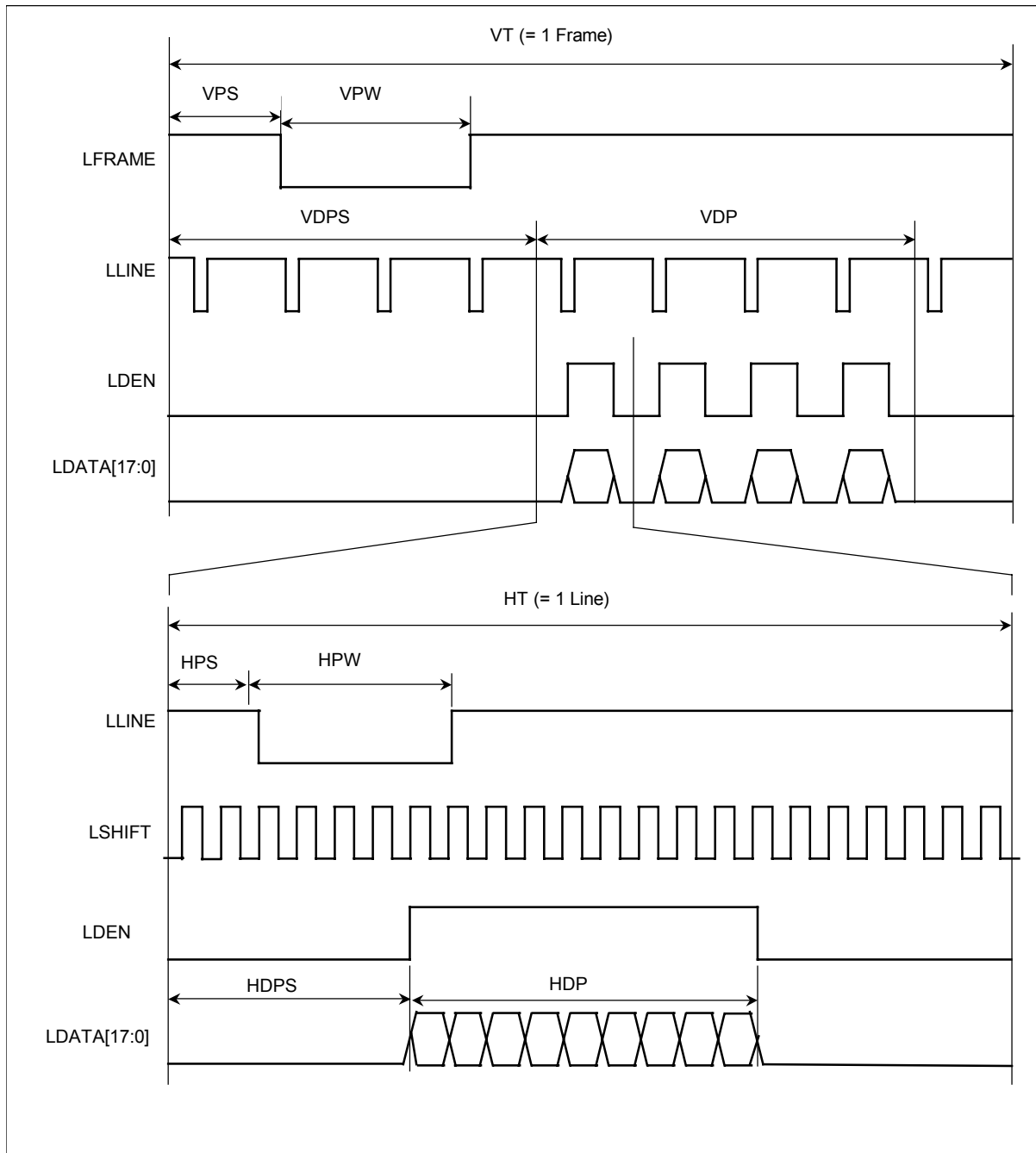

Figure 10-22 : Generic TFT Panel Timing

- VT = Vertical Total  
 =  $[(\text{REG}[19\text{h}] \text{ bits } 1-0, \text{REG}[18\text{h}] \text{ bits } 7-0) + 1] \text{ lines}$
- VPS = LFRAME Pulse Start Position  
 =  $[(\text{REG}[27\text{h}] \text{ bits } 1-0, \text{REG}[26\text{h}] \text{ bits } 7-0)] \times \text{HT} + (\text{REG}[31\text{h}] \text{ bits } 1-0, \text{REG}[30\text{h}] \text{ bits } 7-0) \text{ pixels}$
- VPW = LFRAME Pulse Width  
 =  $[(\text{REG}[24\text{h}] \text{ bits } 2-0) + 1] \times \text{HT} + (\text{REG}[35\text{h}] \text{ bits } 1-0, \text{REG}[34\text{h}] \text{ bits } 7-0) - (\text{REG}[31\text{h}] \text{ bits } 1-0, \text{REG}[30\text{h}] \text{ bits } 7-0) \text{ pixels}$

VDPS = Vertical Display Period Start Position  
 =  $[(\text{REG}[1\text{Fh}]\text{bits } 1-0, \text{REG}[1\text{Eh}]\text{bits } 7-0)]$  lines  
 VDP = Vertical Display Period  
 =  $[(\text{REG}[1\text{Dh}]\text{bits } 1-0, \text{REG}[1\text{Ch}]\text{bits } 7-0) + 1]$  lines  
 \* The VDP must be a minimum of 2 lines  
 HT = Horizontal Total  
 =  $[(\text{REG}[12\text{h}]\text{ bits } 6-0) + 1] \times 8$  pixels  
 HPS = LLINE Pulse Start Position  
 =  $[(\text{REG}[23\text{h}]\text{ bits } 1-0, \text{REG}[22\text{h}]\text{ bits } 7-0) + 1]$  pixels  
 HPW = LLINE Pulse Width  
 =  $[(\text{REG}[20\text{h}]\text{ bits } 6-0) + 1]$  pixels  
 HDPS = Horizontal Display Period Start Position  
 =  $[(\text{REG}[17\text{h}]\text{ bits } 1-0, \text{REG}[16\text{h}]\text{ bits } 7-0) + 5]$  pixels  
 HDP = Horizontal Display Period  
 =  $[(\text{REG}[14\text{h}]\text{ bits } 6-0) + 1] \times 8$  pixels  
 \* The HDP must be a minimum of 32 pixels and can be increased by multiples of 8.

\*Panel Type Bits (REG[10h] bits 2-0) = 001 (TFT)  
 \*LLINE Pulse Polarity Bit (REG[24h] bit 7) = 0 (active low)  
 \*LFRAME Polarity Bit (REG[20h] bit 7) = 0 (active low)

#### 10.4.7 9/12/18-Bit TFT Panel Timing

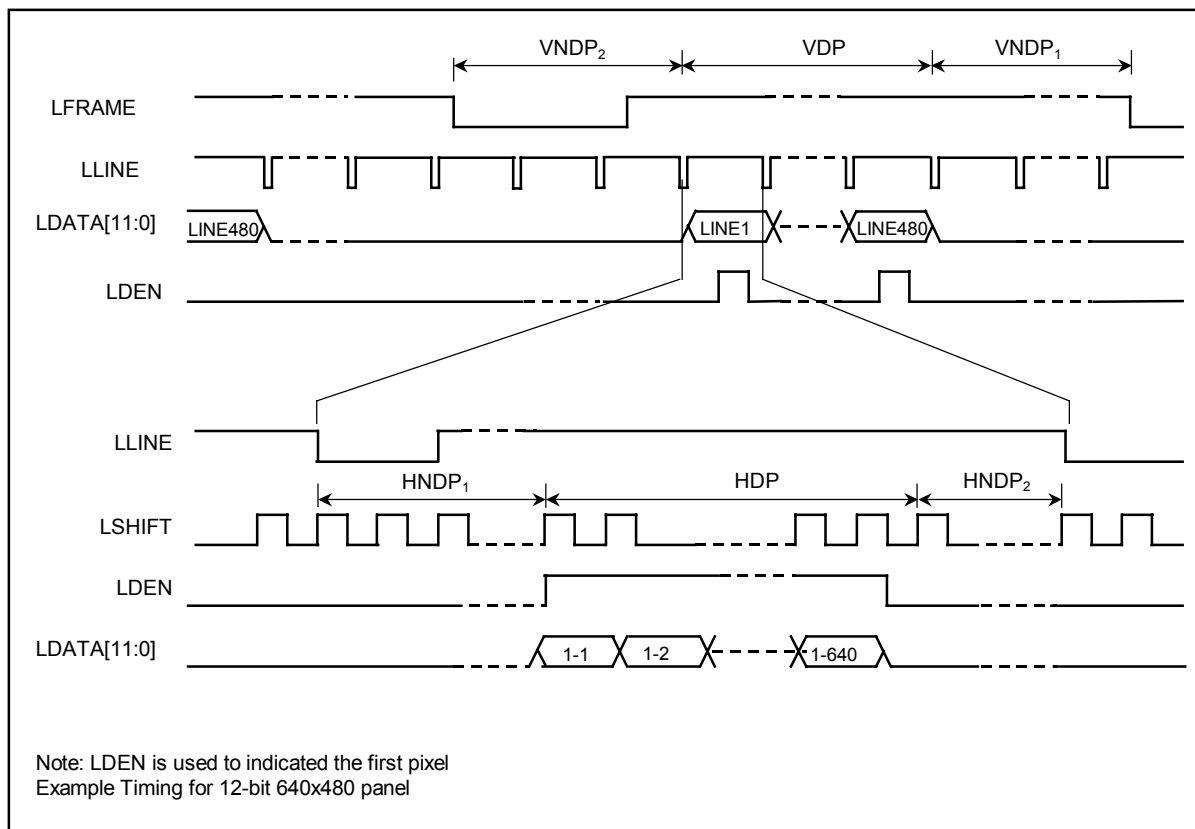

Figure 10-23 : 12-Bit TFT Panel Timing



VDP = Vertical Display Period  
 = VDP Lines  
 VNDP = Vertical Non-Display Period  
 = VNDP1 + VNDP2  
 = VT – VDP Lines  
 VNDP1 = Vertical Non-Display Period 1  
 = VNDP - VNDP2 Lines  
 VNDP2 = Vertical Non-Display Period 2  
 = VDPS - VPS Lines if negative add VT  
 HDP = Horizontal Display Period  
 = HDP Ts  
 HNDP = Horizontal Non-Display Period  
 = HNDP1 + HNDP2  
 = HT - HDP Ts  
 HNDP1 = Horizontal Non-Display Period 1  
 = HDPS - HPS Ts if negative add HT  
 HNDP2 = Horizontal Non-Display Period 2  
 = HPS – (HDP + HDPS) Ts if negative add HT

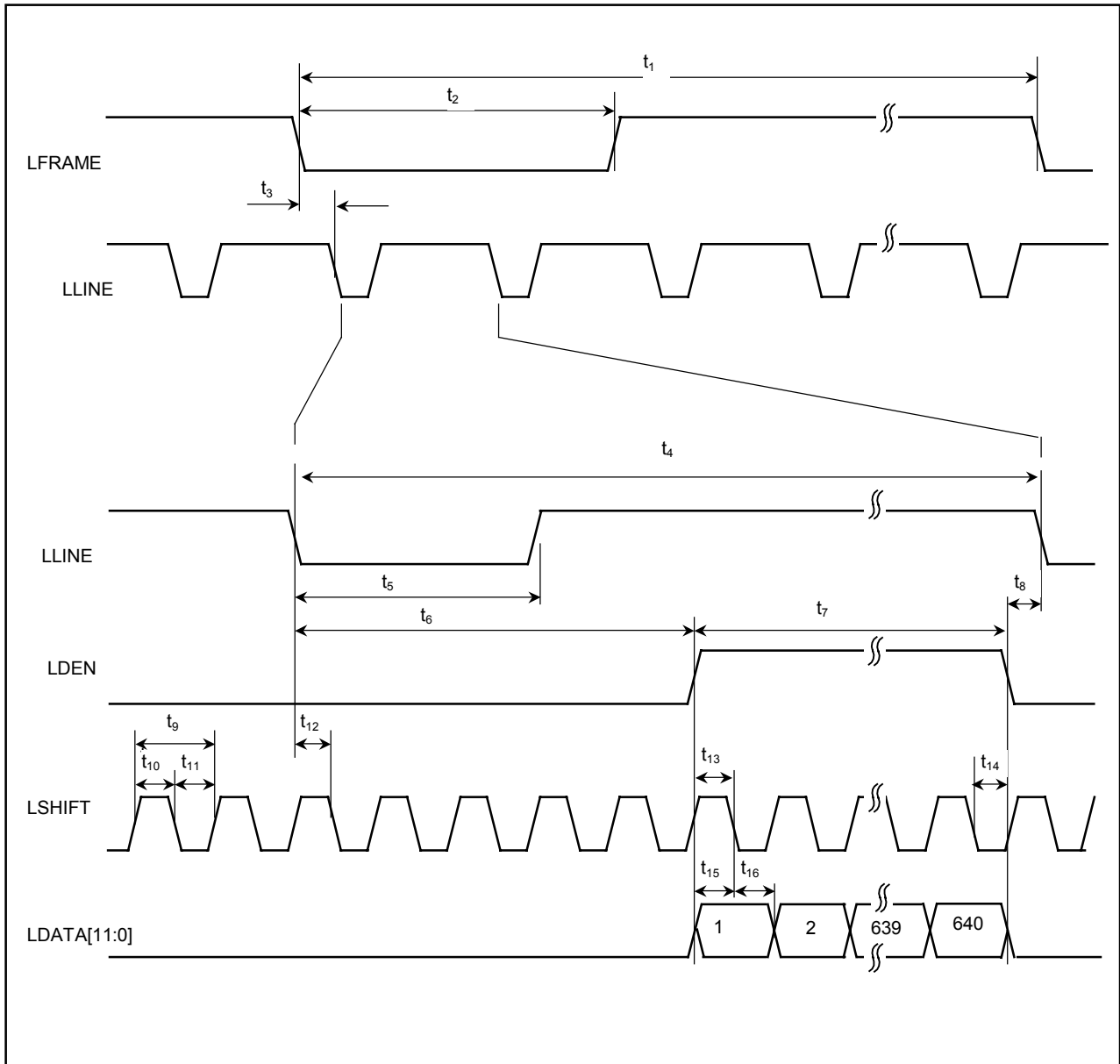

Figure 10-24 : TFT A.C. Timing

**Table 10-19 : TFT A.C. Timing**

Symbol	Parameter	Min	Typ	Max	Units
t <sub>1</sub>	LFRAME cycle time	VT			Lines
t <sub>2</sub>	LFRAME pulse width low	VPW			Lines
t <sub>3</sub>	LFRAME falling edge to LLINE falling edge phase difference	HPS			Ts(note1)
t <sub>4</sub>	LLINE cycle time	HT			Ts
t <sub>5</sub>	LLINE pulse width low	HPW			Ts
t <sub>6</sub>	LLINE falling edge to LDEN active	note 2		250	Ts
t <sub>7</sub>	LDEN pulse width	HDP			Ts
t <sub>8</sub>	LDEN falling edge to LLINE falling edge	note 3			Ts
t <sub>9</sub>	LSHIFT period	1			Ts
t <sub>10</sub>	LSHIFT pulse width high	0.5			Ts
t <sub>11</sub>	LSHIFT pulse width low	0.5			Ts
t <sub>12</sub>	LLINE setup to LSHIFT falling edge	0.5			Ts
t <sub>13</sub>	LDEN to LSHIFT falling edge setup time	0.5			Ts
t <sub>14</sub>	LDEN hold from LSHIFT falling edge	0.5			Ts
t <sub>15</sub>	Data setup to LSHIFT falling edge	0.5			Ts
t <sub>16</sub>	Data hold from LSHIFT falling edge	0.5			Ts

1. Ts = pixel clock period
2. t<sub>6</sub>min = HDPS - HPS                      if negative add HT
3. t<sub>8</sub>min = HPS - (HDP + HDPS )        if negative add HT

### 10.4.8 160x160 Sharp HR-TFT Panel Timing (e.g. LQ031B1DDxx)

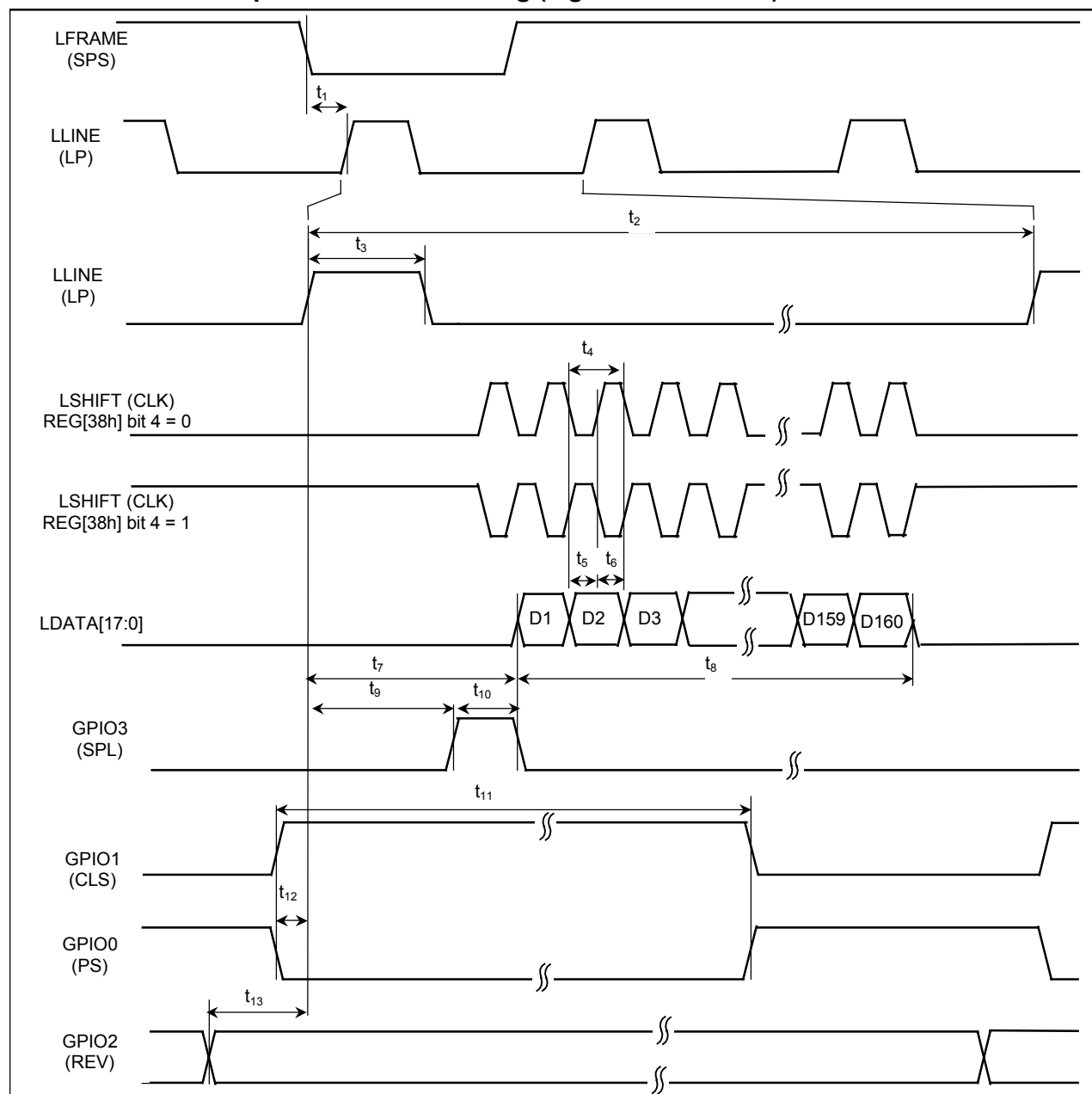
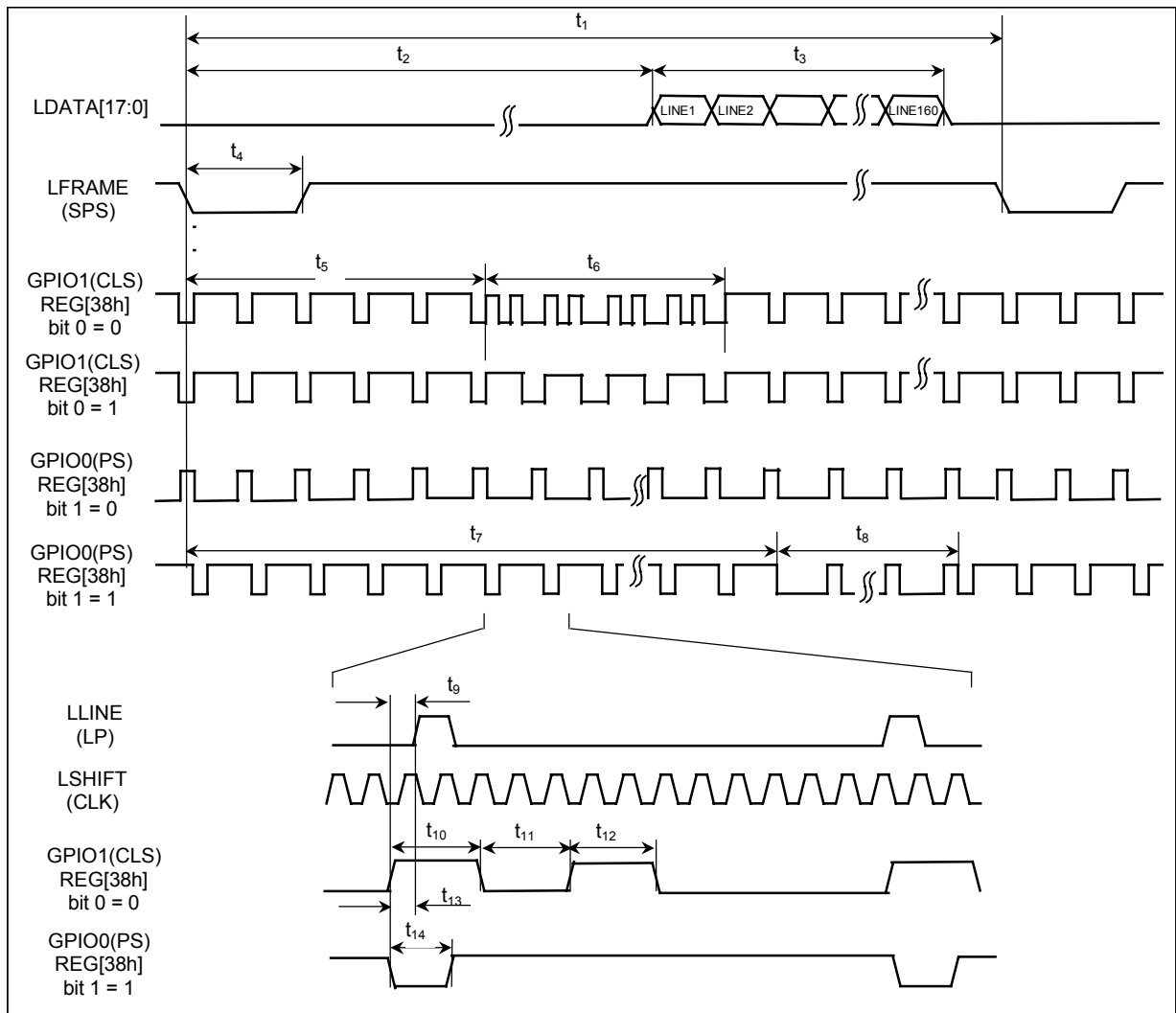

Figure 10-25 : 160x160 Sharp HR-TFT Panel Horizontal Timing

**Table 10-20 : 160x160 Sharp HR-TFT Horizontal Timing**

Symbol	Parameter	Min	Typ	Max	Units
t <sub>1</sub>	LLINE start position		13		Ts (note 1)
t <sub>2</sub>	Horizontal total period		180		Ts
t <sub>3</sub>	LLINE width		2		Ts
t <sub>4</sub>	LSHIFT period		1		Ts
t <sub>5</sub>	Data setup to LSHIFT rising edge	0.5			Ts
t <sub>6</sub>	Data hold from LSHIFT rising edge	0.5			Ts
t <sub>7</sub>	Horizontal display start position		5		Ts
t <sub>8</sub>	Horizontal display period		160		Ts
t <sub>9</sub>	LLINE rising edge to GPIO3 rising edge		4		Ts
t <sub>10</sub>	GPIO3 pulse width		1		Ts
t <sub>11</sub>	GPIO1(GPIO0) pulse width		136		Ts
t <sub>12</sub>	GPIO1 rising edge (GPIO0 falling edge) to LLINE rise edge		4		Ts
t <sub>13</sub>	GPIO2 toggle edge to LLINE rise edge		10		Ts

1. Ts = pixel clock period
2. t<sub>1typ</sub> = (REG[22h] bits 7-0) + 1
3. t<sub>2typ</sub> = ((REG[12h] bits 6-0) + 1) x 8
4. t<sub>3typ</sub> = (REG[20h] bits 6-0) + 1
5. t<sub>7typ</sub> = ((REG[16h] bits 7-0) + 1) - ((REG[22h] bits 7-0) + 1)
6. t<sub>8typ</sub> = ((REG[14h] bits 6-0) + 1) x 8



**Figure 10-26 : 160x160 Sharp HR-TFT Panel Vertical Timing**

**Table 10-21 : 160x160 Sharp HR-TFT Panel Vertical Timing**

Symbol	Parameter	Min	Typ	Max	Units
t <sub>1</sub>	Vertical total period		203		Lines
t <sub>2</sub>	Vertical display start position		40		Lines
t <sub>3</sub>	Vertical display period		160		Lines
t <sub>4</sub>	FPRAME sync pulse width		2		Lines
t <sub>5</sub> <sup>1</sup>	LFRAME falling edge to GPIO1 alternate timing start		5		Lines
t <sub>6</sub> <sup>1</sup>	GPIO1 alternate timing period		4		Lines
t <sub>7</sub> <sup>2</sup>	LFRAME falling edge to GPIO0 alternate timing start		40		Lines
t <sub>8</sub> <sup>2</sup>	GPIO0 alternate timing period		162		Lines
t <sub>9</sub>	GPIO1 first pulse rising edge to LLINE rising edge		4		Ts (note 1)
t <sub>10</sub> <sup>1</sup>	GPIO1 first pulse width		48		Ts
t <sub>11</sub> <sup>1</sup>	GPIO1 first pulse falling edge to second pulse rising edge		40		Ts
t <sub>12</sub> <sup>1</sup>	GPIO1 second pulse width		48		Ts
t <sub>13</sub> <sup>2</sup>	GPIO0 falling edge to LLINE rising edge		4		Ts
t <sub>14</sub> <sup>2</sup>	GPIO0 low pulse width		24		Ts

1. Ts = pixel clock period

<sup>1</sup> Timing for CLS signal change bit enabled (REG[38h] bit 0 = 0) only

<sup>2</sup> Timing for PS signal change bit enabled (REG[38h] bit 1 = 1) only

### 10.4.9 Generic HR-TFT Panel Timing

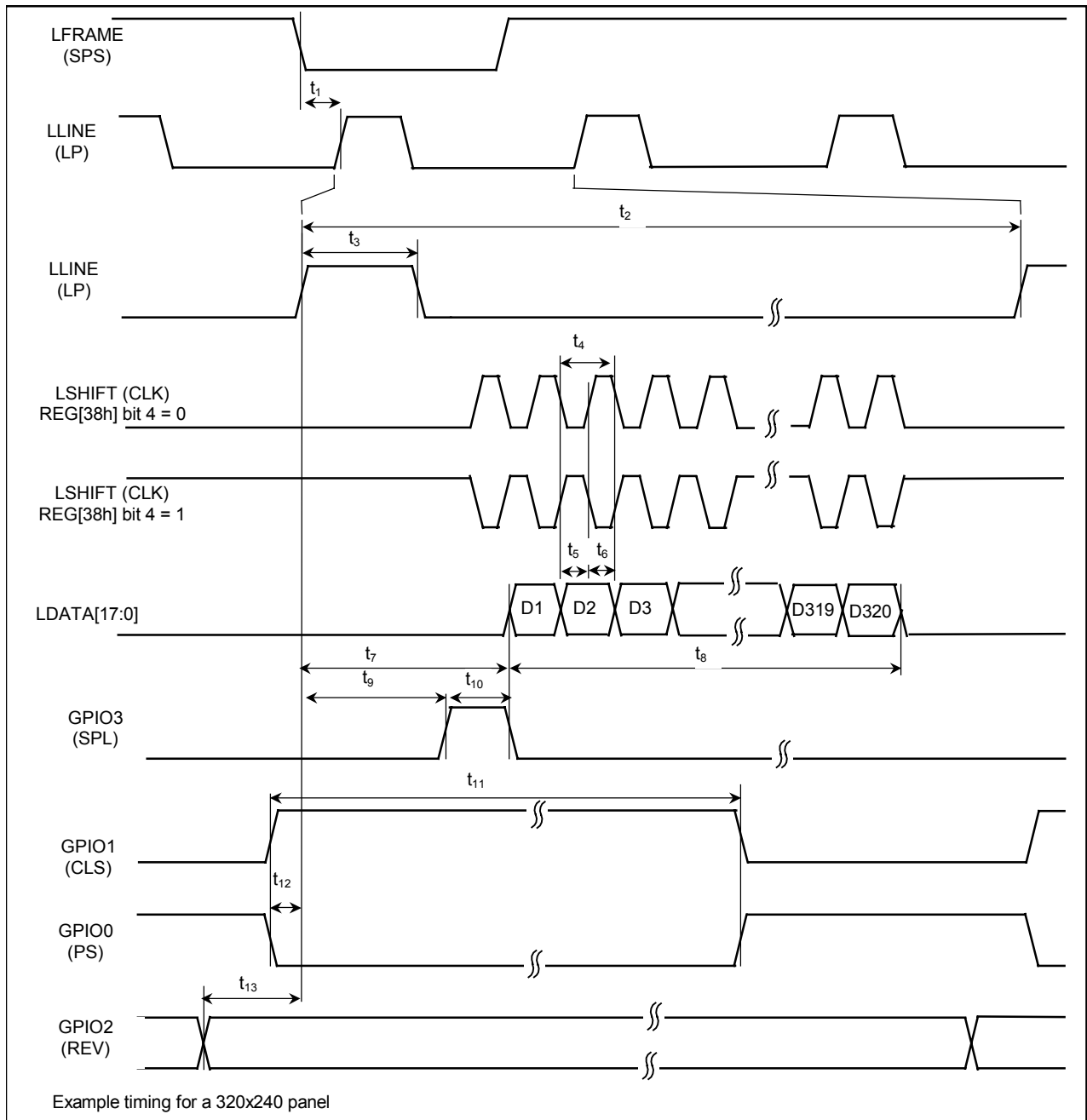

Figure 10-27 : HR-TFT Panel Horizontal Timing



**Table 10-22 : 320x240 HR-TFT Panel Horizontal Timing**

Symbol	Parameter	Min	Typ	Max	Units
t <sub>1</sub>	LLINE start position		14		Ts (note 1)
t <sub>2</sub>	Horizontal total period	400		440	Ts
t <sub>3</sub>	LLINE width		1		Ts
t <sub>4</sub>	LSHIFT period		1		Ts
t <sub>5</sub>	Data setup to LSHIFT rising edge	0.5			Ts
t <sub>6</sub>	Data hold from LSHIFT rising edge	0.5			Ts
t <sub>7</sub>	Horizontal display start position		60		Ts
t <sub>8</sub>	Horizontal display period		320		Ts
t <sub>9</sub>	LLINE rising edge to GPIO3 rising edge		59		Ts
t <sub>10</sub>	GPIO3 pulse width		1		Ts
t <sub>11</sub>	GPIO1(GPIO0) pulse width		353		Ts
t <sub>12</sub>	GPIO1 rising edge (GPIO0 falling edge) to LLINE rise edge		5		Ts
t <sub>13</sub>	GPIO2 toggle edge to LLINE rise edge		11		Ts

1. Ts = pixel clock period
2. t<sub>1typ</sub> = (REG[22h] bits 7-0) + 1
3. t<sub>2typ</sub> = ((REG[12h] bits 6-0) + 1) x 8
4. t<sub>3typ</sub> = (REG[20h] bits 6-0) + 1
5. t<sub>7typ</sub> = ((REG[16h] bits 7-0) + 1) - ((REG[22h] bits 7-0) + 1)
6. t<sub>8typ</sub> = ((REG[14h] bits 6-0) + 1) x 8

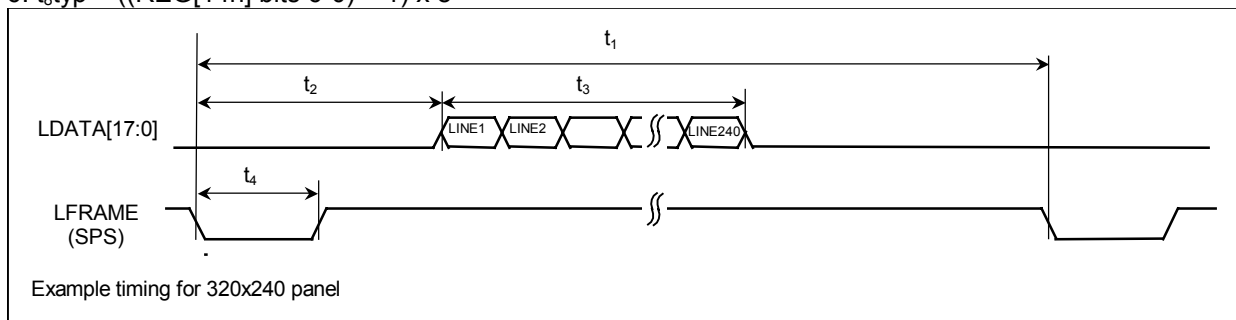

**Figure 10-28 : HR-TFT Panel Vertical Timing**

**Table 10-23 : 320x240 HR-TFT Panel Vertical Timing**

Symbol	Parameter	Min	Typ	Max	Units
t <sub>1</sub>	Vertical total period	245		330	Lines
t <sub>2</sub>	Vertical display start position		4		Lines
t <sub>3</sub>	Vertical display period		240		Lines
t <sub>4</sub>	Vertical sync pulse width		2		Lines

## 11 Clocks

The following diagram provides a block diagram of the SSD1906 internal clocks.

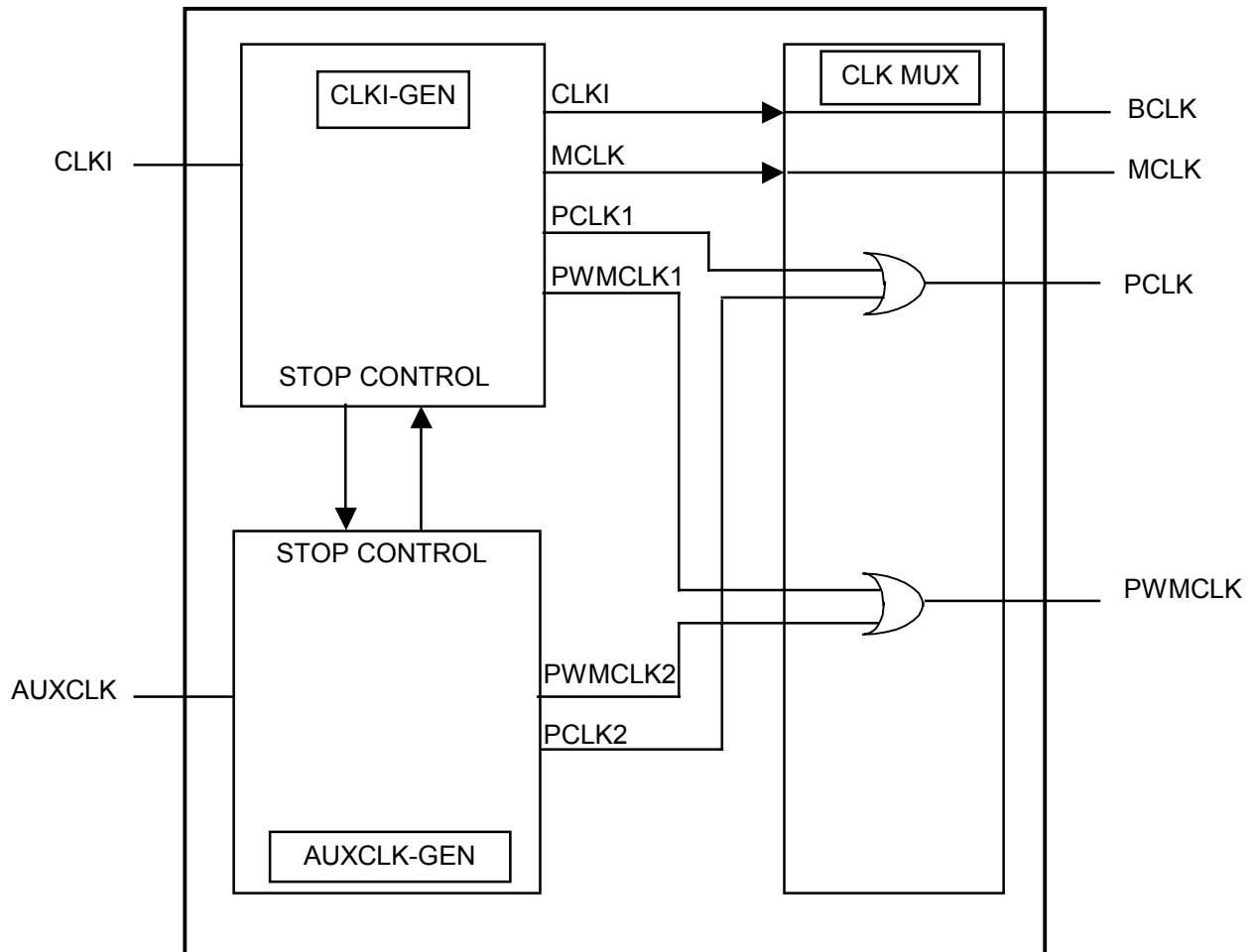

Figure 11-1 : Clock Generator Block Diagram

### 11.1 Clock Descriptions

#### 11.1.1 BCLK

BCLK is an internal clock derived from CLKI. BCLK can be a divided version ( $\div 1$ ,  $\div 2$ ,  $\div 3$ ,  $\div 4$ ) of CLKI. CLKI is typically derived from the host CPU bus clock.

The source clock options for BCLK may be selected as in the following table.

Table 11-1 : BCLK Clock Selection

Source Clock Options	BCLK Selection
CLKI	CF[7:6] = 00
CLKI $\div 2$	CF[7:6] = 01
CLKI $\div 3$	CF[7:6] = 10
CLKI $\div 4$	CF[7:6] = 11

**Note**

For synchronous bus interfaces, it is recommended that BCLK be set the same as the CPU bus clock (not a divided version of CLKI) e.g. SH-3, SH-4.

**11.1.2 MCLK**

MCLK provides the internal clock required to access the embedded SRAM. The SSD1906 is designed with efficient power saving control for clocks (clocks are turned off when not used).

Furthermore, reducing the MCLK frequency relative to the BCLK frequency increases the CPU cycle latency and so reduces screen update performance. For a balance of power saving and performance, the MCLK should be configured to have a high enough frequency setting to provide sufficient screen refresh as well as acceptable CPU cycle latency.

The source clock options for MCLK may be selected as in the following table.

**Table 11-2 : MCLK Clock Selection**

Source Clock Options	MCLK Selection (REG[04h])
BCLK	00h
BCLK ÷ 2	10h
BCLK ÷ 3	20h
BCLK ÷ 4	30h

**11.1.3 PCLK**

PCLK is the internal clock used to control the LCD panel. PCLK should be chosen to match the optimum frame rate of the LCD panel. See Section 13 "Frame Rate Calculation" for details on the relationship between PCLK and frame rate.

Some flexibility is possible in the selection of PCLK. Firstly, LCD panels typically have a range of permissible frame rates. Secondly, it may be possible to choose a higher PCLK frequency and tailor the horizontal and vertical non-display periods to lower the frame-rate to its optimal value.

The source clock options for PCLK may be selected as in the Table 11-3 : PCLK Clock Selection.

**Table 11-3 : PCLK Clock Selection**

Source Clock Options	PCLK Selection (REG[05h])
MCLK	00h
MCLK ÷ 2	10h
MCLK ÷ 3	20h
MCLK ÷ 4	30h
MCLK ÷ 8	40h
BCLK	01h
BCLK ÷ 2	11h
BCLK ÷ 3	21h
BCLK ÷ 4	31h
BCLK ÷ 8	41h
CLKI	02h
CLKI ÷ 2	12h
CLKI ÷ 3	22h
CLKI ÷ 4	32h
CLKI ÷ 8	42h
AUXCLK	03h
AUXCLK ÷ 2	13h
AUXCLK ÷ 3	23h
AUXCLK ÷ 4	33h
AUXCLK ÷ 8	43h

There is a relationship between the frequency of MCLK and PCLK that must be maintained, see Table 11-4 : Relationship between MCLK and PCLK.

**Table 11-4 : Relationship between MCLK and PCLK**

Color Depth (bpp)	MCLK to PCLK Relationship
16	$f_{MCLK} \geq f_{PCLK} \times 2$
8	$f_{MCLK} \geq f_{PCLK}$
4	$f_{MCLK} \geq f_{PCLK} \div 2$
2	$f_{MCLK} \geq f_{PCLK} \div 4$
1	$f_{MCLK} \geq f_{PCLK} \div 8$

#### 11.1.4 PWMCLK

PWMCLK is the internal clock used by the Pulse Width Modulator for output to the panel. The source clock options for PWMCLK may be selected as in the following table.

For further information on controlling PWMCLK, see Section 0 “

Pulse Width Modulation (PWM) Clock and Contrast Voltage (CV) Pulse Configuration Registers”.

**Note**

The SSD1906 provides Pulse Width Modulation output on the pin LPWMOUT. LPWMOUT can be used to control LCD panels which support PWM control of the back-light inverter.

**Table 11-5 : PWMCLK Clock Selection**

Source Clock Options	PWMCLK Selection REG[B1h] bit 0
CLKI	0
AUXCLK	1

**11.2 Clocks versus Functions**

Table 11-6 : SSD1906 Internal Clock Requirements, lists the internal clocks required for the following SSD1906 functions.

**Table 11-6 : SSD1906 Internal Clock Requirements**

Function	Bus Clock (BCLK)	Memory Clock (MCLK)	Pixel Clock (PCLK)	PWM Clock (PWMCLK)
Register Read/Write	Required	Not Required	Not Required	Not Required
Memory Read/Write	Required	Required	Not Required	Not Required
Look-Up Table Register Read/Write	Required	Not Required	Not Required	Not Required
Software Power Saving	Required	Not Required	Not Required	Not Required
LCD Output	Required	Required	Required	Not Required
PWM / CV Output	Required	Required	Required	Required

## 12 Power Saving Mode

Power Saving Mode is incorporated into the SSD1906 to accommodate the need for power reduction in the hand-held device market. This mode is enabled via the Power Saving Mode Enable bit (REG[A0h] bit 0).

Power Saving Mode power down the panel and stop display refresh accesses to the display buffer.

**Table 12-1 : Power Saving Mode Function Summary**

	Software Power Saving	Normal
IO Access Possible?	Yes	Yes
Memory Access Possible?	No <sup>1</sup>	Yes
Look-Up Table Registers Access Possible?	Yes	Yes
Sequence Controller Running?	No	Yes
Display Active?	No	Yes
LCD Interface Outputs	Forced Low	Active
PWMCLK	Stopped	Active
GPIO3:0 Pins configured for HR-TFT <sup>2</sup>	Forced Low	Active
GPIO Pins configured as GPIOs Access Possible ? <sup>2</sup>	Yes <sup>3</sup>	Yes

### Note :

<sup>1</sup> When Power Saving mode is enabled, the memory controlled is powered down. The status of the memory controlled is indicated by the Memory Controller Power Saving Status bit (REG[A0h] bit 3). For Power Saving Status AC timing, see Section 10.3.3 “Power Saving Status”.

<sup>2</sup> GPIO Pins are configured using the configurations pin CF3 which is latched on the rising edge of RESET#. For information on CF3, see Table 5-6 : Summary of Power-On/Reset Options.

<sup>3</sup> GPIOs can be accessed and if configured as outputs can be changed.

After reset, the SSD1906 stays in Power Saving Mode. Software must initialize the chip (i.e. programs all registers) and then clear the Power Saving Mode Enable bit.

## 13 Frame Rate Calculation

The following formula is used to calculate the display frame rate.

$$FrameRate = \frac{f_{PCLK}}{(HT) \times (VT)}$$

Where:

$f_{PCLK}$	= PCLK frequency (Hz)
HT	= Horizontal Total = ((REG[12h] bits 6-0) + 1) x 8 Ts
VT	= Vertical Total = ((REG[19h] bits 1-0, REG[18h] bits 7-0) + 1) Lines

## 14 Display Data Formats

The following diagrams show the display mode data formats.

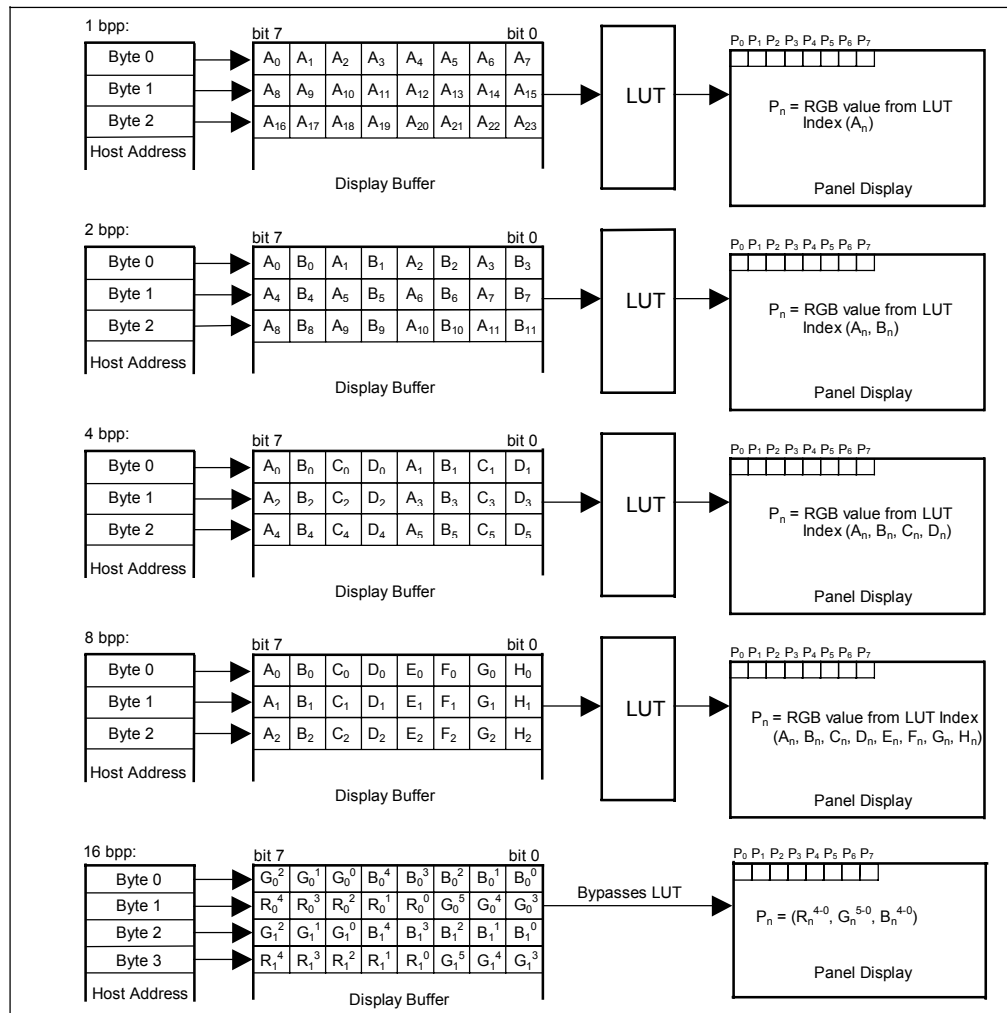

Figure 14-1 : 1/2/4/8/16 Bit-Per-Pixel Display Data Memory Organization

### Note

1. For 16 bpp format,  $R_n$ ,  $G_n$ ,  $B_n$  represent the red, green, and blue color components.

## 15 Look-Up Table Architecture

The following figures are intended to show the display data output path only.

### Note

When Color Invert is enabled the display color is inverted after the Look-Up Table.

### 15.1 Monochrome Modes

The green Look-Up Table (LUT) is used for all monochrome modes.

#### 15.1.1 1 Bit-per-pixel Monochrome Mode

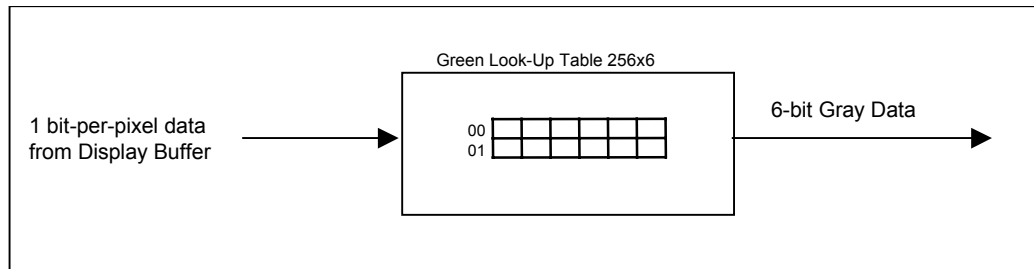

Figure 15-1 : 1 Bit-per-pixel Monochrome Mode Data Output Path

#### 15.1.2 2 Bit-per-pixel Monochrome Mode

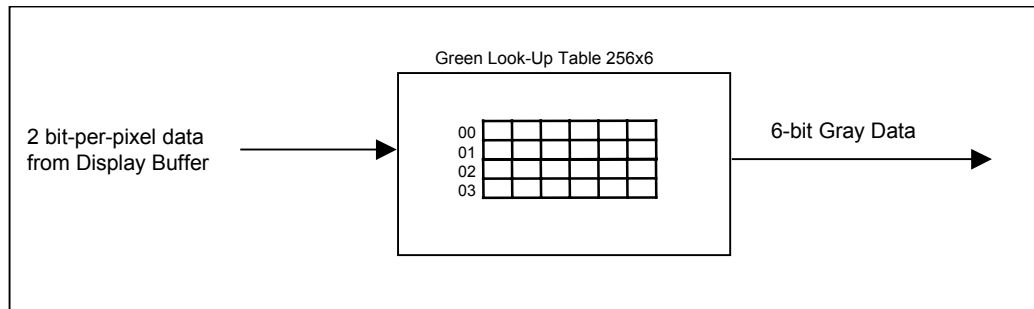

Figure 15-2 : 2 Bit-per-pixel Monochrome Mode Data Output Path



### 15.1.3 4 Bit-per-pixel Monochrome Mode

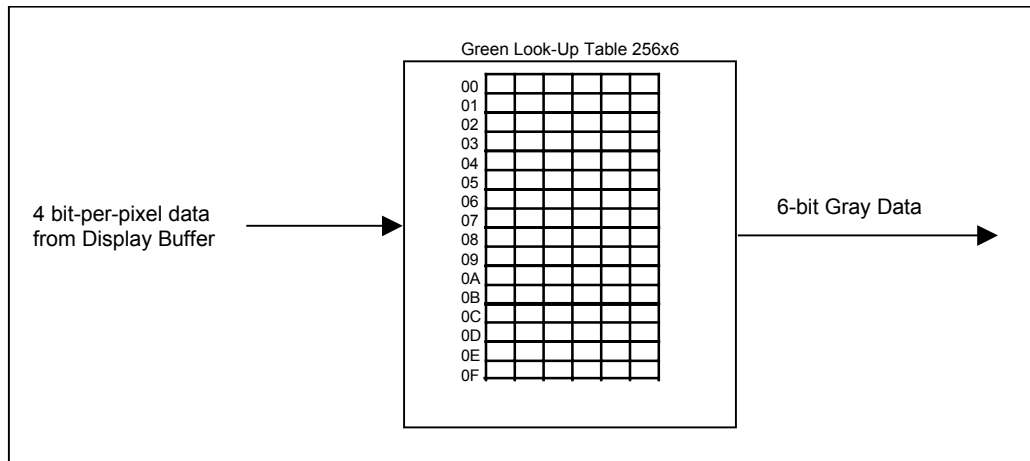

Figure 15-3 : 4 Bit-per-pixel Monochrome Mode Data Output Path

### 15.1.4 8 Bit-per-pixel Monochrome Mode

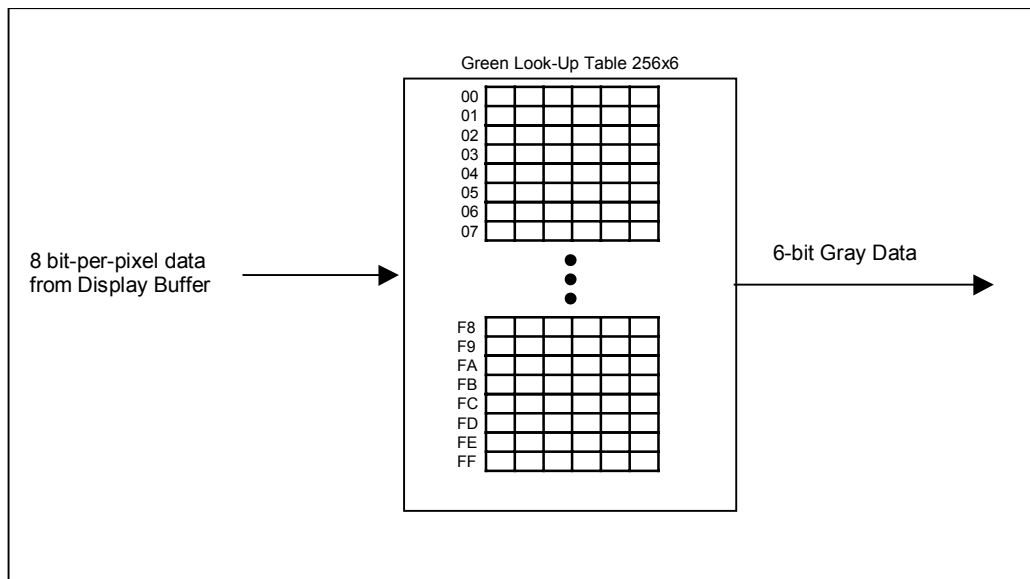

Figure 15-4 : 8 Bit-per-pixel Monochrome Mode Data Output Path

### 15.1.5 16 Bit-Per-Pixel Monochrome Mode

The LUT is bypassed and the green data is directly mapped for this color depth– See Figure 14-1 : 1/2/4/8/16 Bit-Per-Pixel Display Data Memory Organization.

## 15.2 Color Modes

### 15.2.1 1 Bit-Per-Pixel Color

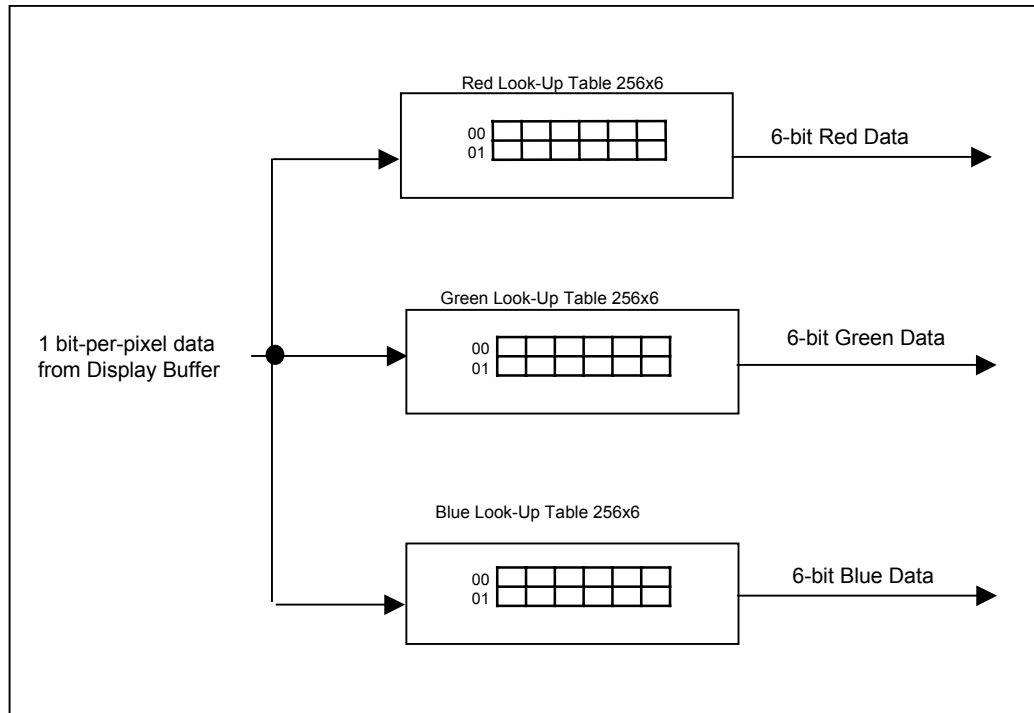

Figure 15-5 : 1 Bit-Per-Pixel Color Mode Data Output Path

### 15.2.2 2 Bit-Per-Pixel Color

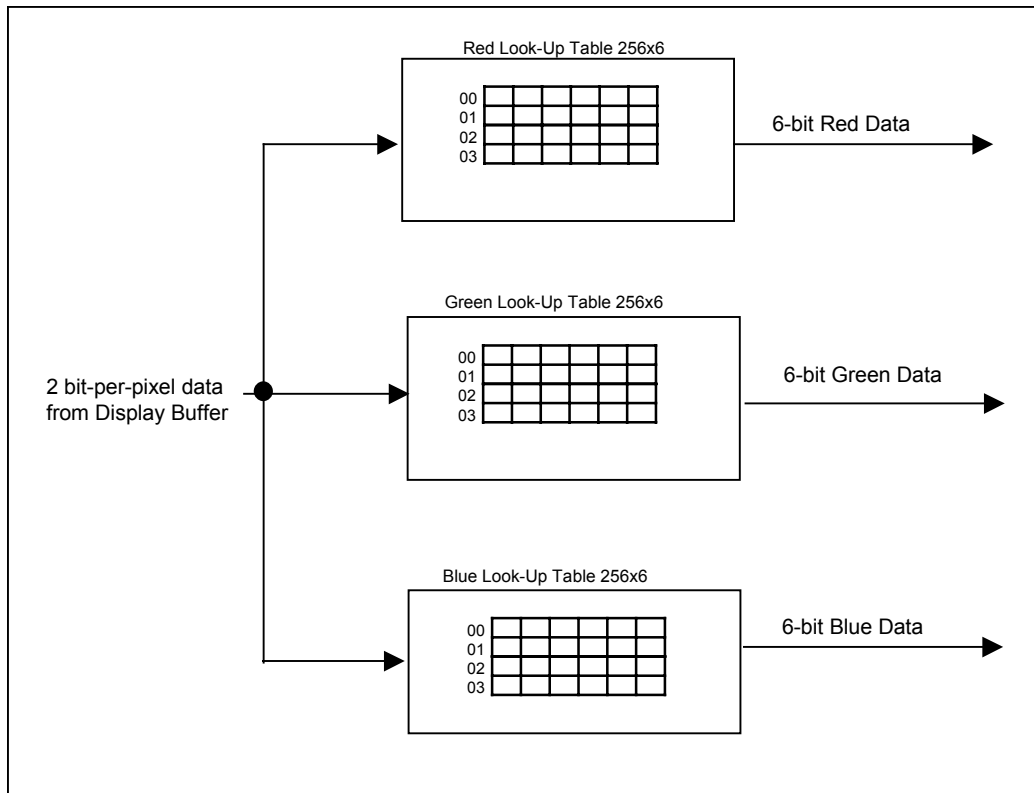

Figure 15-6 : 2 Bit-Per-Pixel Color Mode Data Output Path

### 15.2.3 4 Bit-Per-Pixel Color

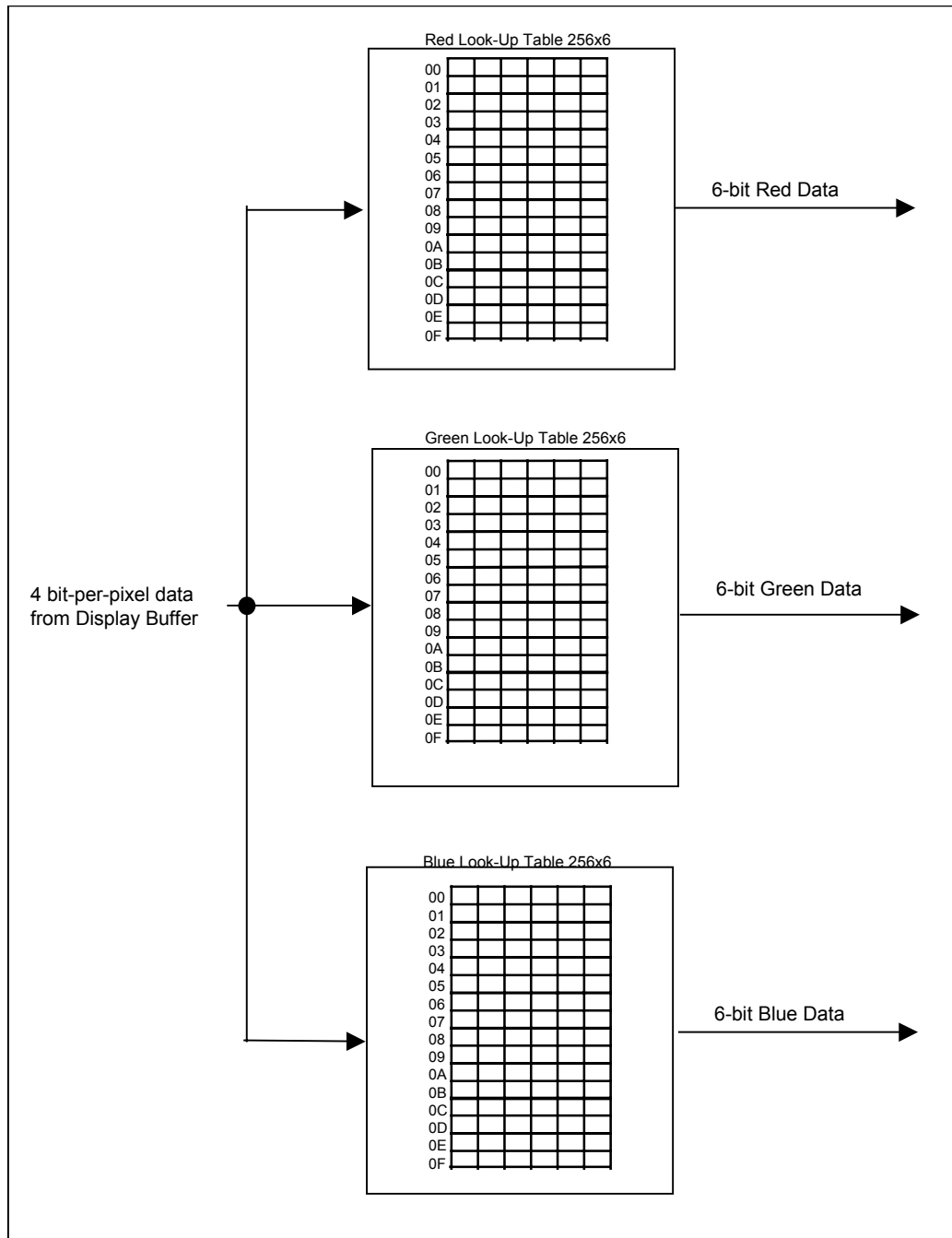

Figure 15-7 : 4 Bit-Per-Pixel Color Mode Data Output Path

## 15.2.4 8 Bit-per-pixel Color Mode

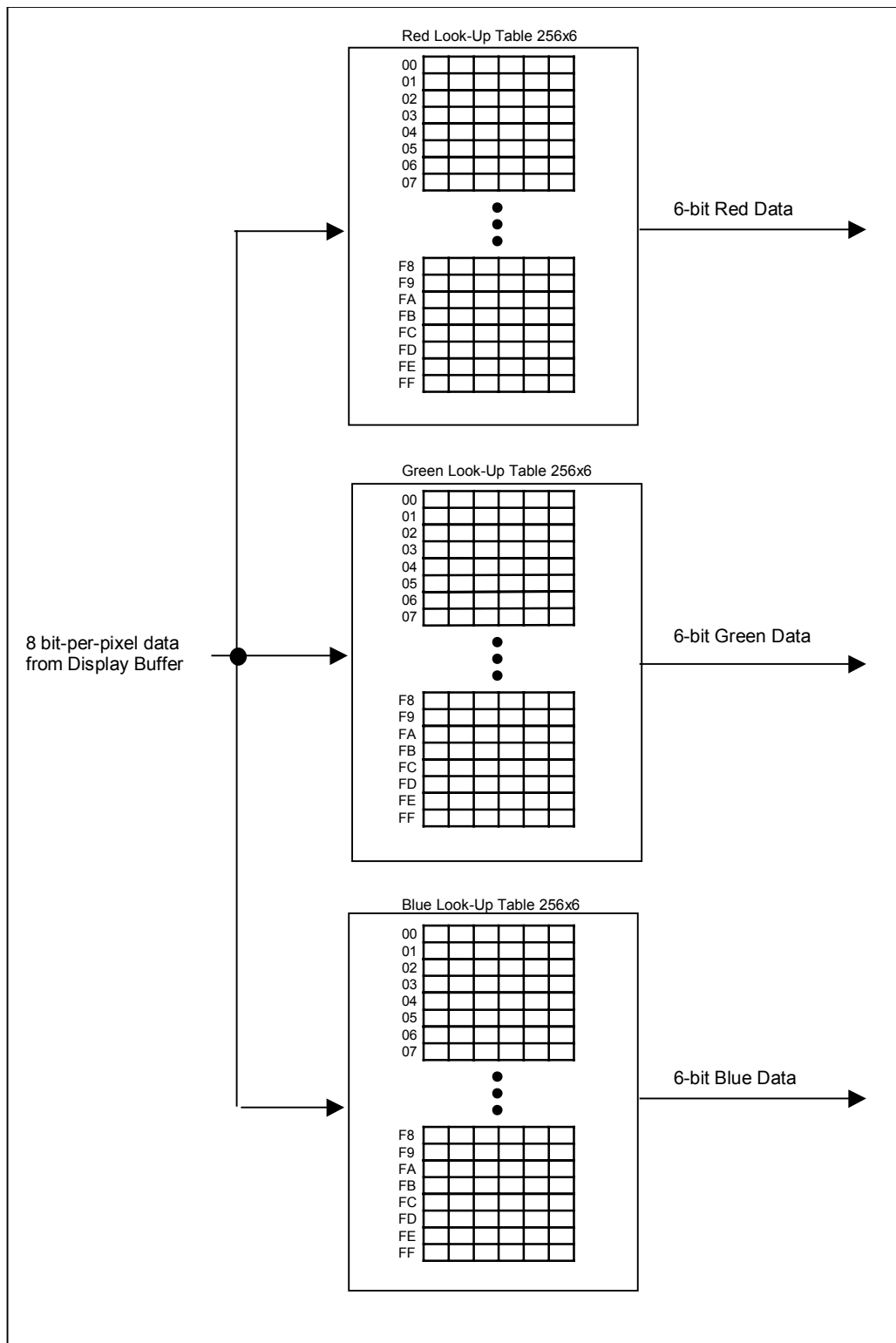

Figure 15-8 : 8 Bit-per-pixel Color Mode Data Output Path

### 15.2.5 16 Bit-Per-Pixel Color Mode

The LUT is bypassed at 16 bpp and the color data is directly mapped for this color depth. The color pixel is arranged as 5-6-5 RGB format. See Figure 14-1 : 1/2/4/8/16 Bit-Per-Pixel Display Data Memory Organization.

## 16 Big-Endian Bus Interface

### 16.1 Byte Swapping Bus Data

The display buffer and register architecture of the SSD1906 is inherently little-endian. If configured as big-endian (CF4 = 1 at reset), bus accesses are automatically handled by byte swapping all read/write data to/from the internal display buffer and registers.

Bus data byte swapping translates all byte accesses correctly to the SSD1906 register and display buffer locations. To maintain the correct translation for 16-bit word access, even address bytes must be mapped to the MSB of the 16-bit word, and odd address bytes to the LSB of the 16-bit word. For example:

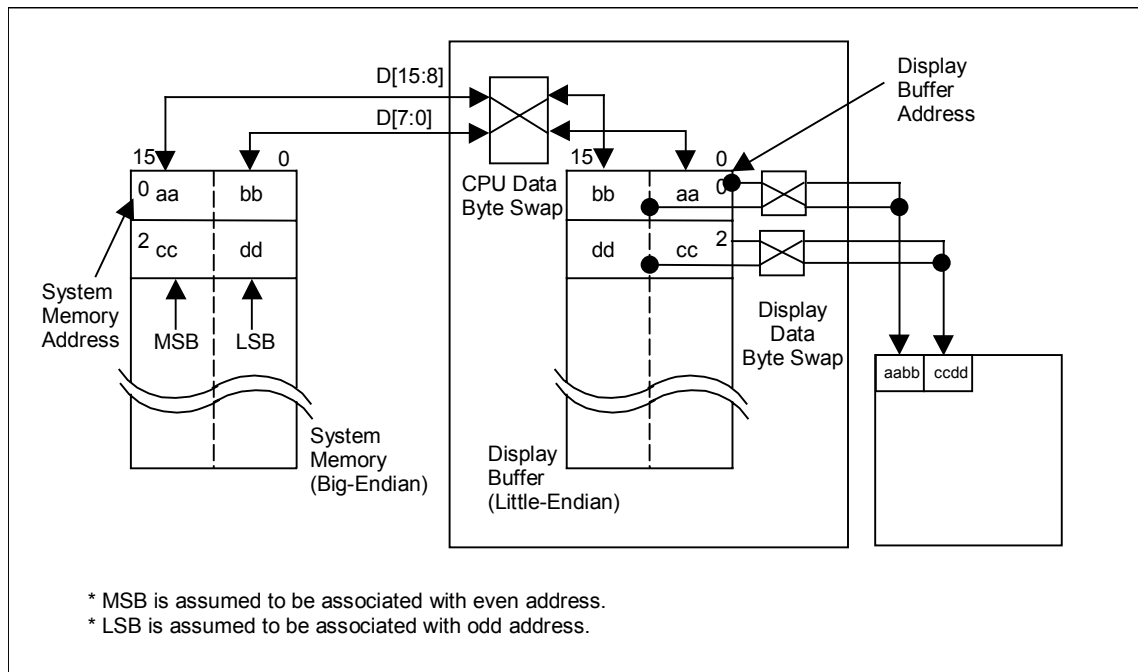

Byte write 11h to register address 1Eh ->	REG[1Eh] <= 11h
Byte write 22h to register address 1Fh ->	REG[1Fh] <= 22h
Word write 1122h to register address 1Eh->	REG[1Eh] <= 11h
	REG[1Fh] <= 22h

Figure 16-1 : Byte-swapping for 16 Bpp

### 16.1.1 16 Bpp Color Depth

For 16 bpp color depth, the Display Data Byte Swap bit (REG[71h] bit 6) must be set to 1

For 16 bpp color depth, the MSB of the 16-bit pixel data is stored at the even system memory address location and the LSB of the 16-bit pixel data is stored at the odd system memory address location. Bus data byte swapping (automatic when the SSD1906 is configured for Big-Endian) causes the 16-bit pixel data to be stored byte-swapped in the SSD1906 display buffer. During display refresh this stored data must be byte-swapped again before it is sent to the display.

### 16.1.2 1/2/4/8 Bpp Color Depth

For 1/2/4/8 bpp color depth, byte swapping must be performed on the bus data but not the display data.

For 1/2/4/8 bpp color depth, the Display Data Byte Swap bit (REG[71h] bit 6) must be set to 0.

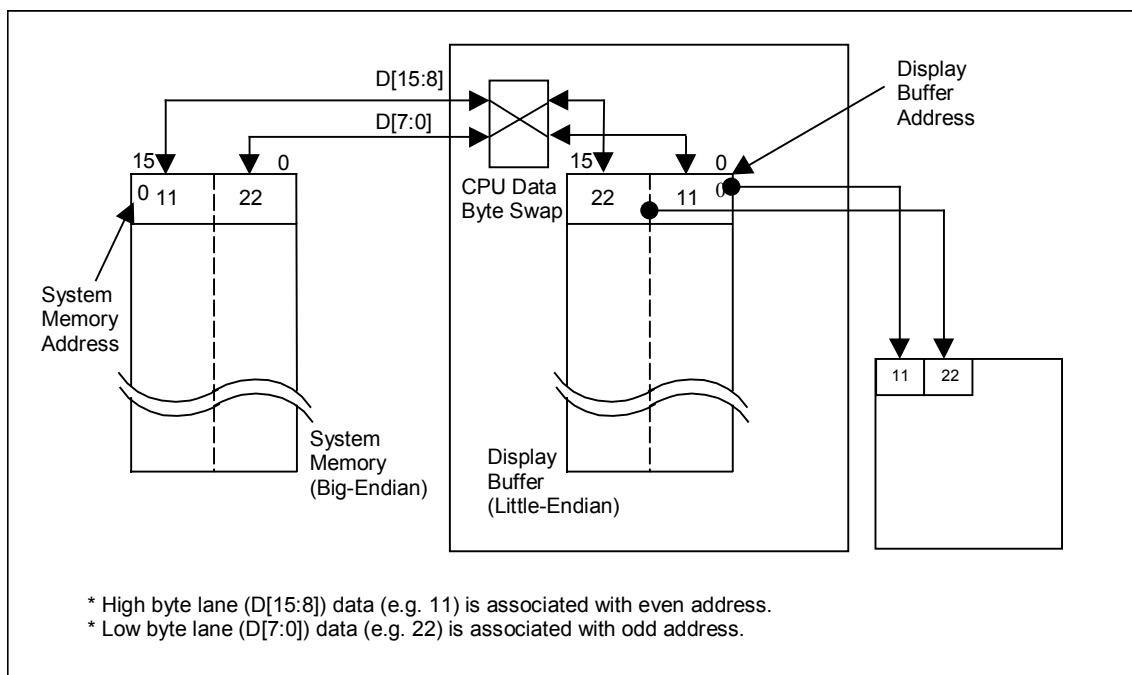
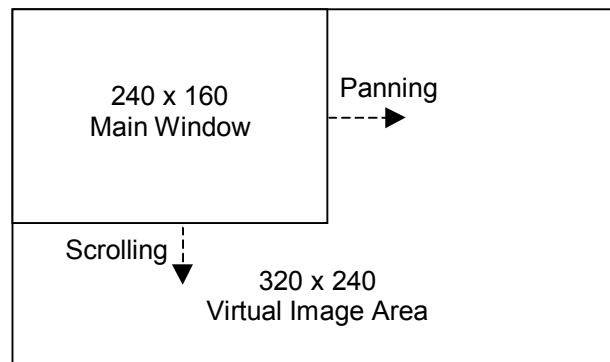

Figure 16-2 : Byte-swapping for 1/2/4/8 Bpp

## 17 Virtual Display Mode

Virtual display refers to the situation where the image to be viewed is larger than the physical display. The difference can be in the horizontal, vertical or both dimensions. To view the image, the display is used as a window into the display buffer. At any given time only a portion of the image is visible. Panning and scrolling are used to view the full image. Panning describes the horizontal (side to side) motion of the display area. Scrolling describes the vertical (up and down) motion of the display area.

The Main Window Display Start Address register specifies the starting address of main window image in the display buffer. The Main Window Line Address Offset register determines the number of horizontal pixels in the virtual image. Figure 17-1 : Main Window inside Virtual Image Area illustrates the situation.



**Figure 17-1 : Main Window inside Virtual Image Area**



## 18 Display Rotate Mode

Most computer displays are refreshed in landscape orientation – from left to right and top to bottom. Computer images are stored in the same manner. Display Rotate Mode is designed to rotate the displayed image on an LCD by 90°, 180°, or 270° in a counter-clockwise direction. The rotation is done in hardware and is transparent to the user for all display buffer reads and writes. By processing the rotation in hardware, Display Rotate Mode offers a performance advantage over software rotation of the displayed image.

The image is not actually rotated in the display buffer since there is no address translation during CPU read/write. The image is rotated during display refresh.

### 18.1 90° Display Rotate Mode

The following figure shows how the programmer sees a 320x480 rotated image and how the image is being displayed. The application image is written to the SSD1906 in the following sense: A–B–C–D. The display is refreshed by the SSD1906 in the following sense: B–D–A–C.

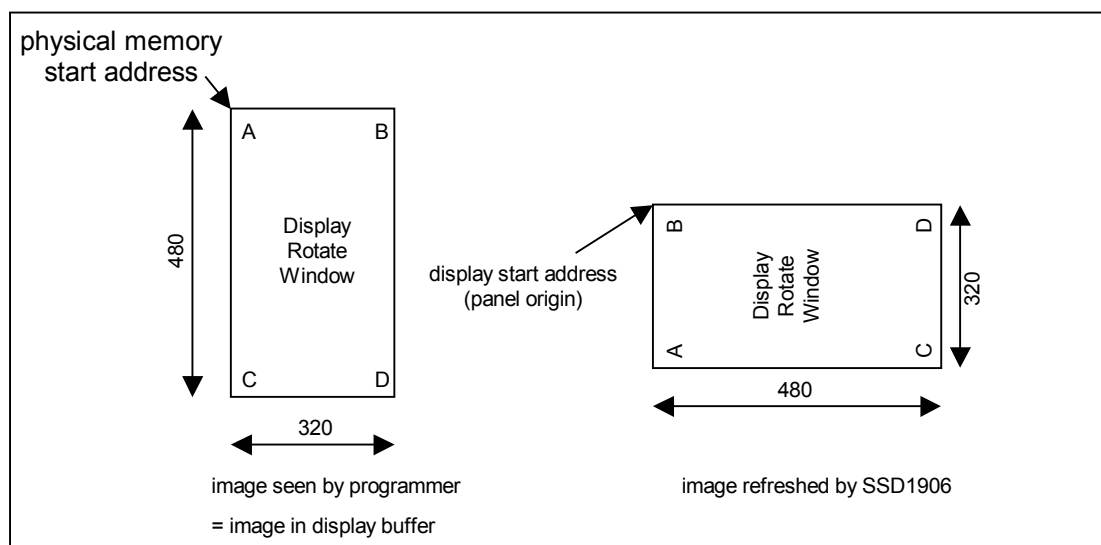

**Figure 18-1 : Relationship Between The Screen Image and the Image Refreshed in 90° Display Rotate Mode.**

#### 18.1.1 Register Programming

##### Enable 90° Display Rotate Mode

Set Display Rotate Mode Select bits to 01 (REG[71h] bits 1:0 = 01).

##### Display Start Address

The display refresh circuitry starts at pixel “B”, therefore the Main Window Display Start Address registers (REG[74h], REG[75h], REG[76h]) must be programmed with the address of pixel “B”.

To calculate the value of the address of pixel “B” use the following formula (assumes 8bpp color depth).

$$\begin{aligned} & \text{Main Window Display Start Address bits 16-0} \\ &= ((\text{Image address} + (\text{panel height} \times \text{bpp} \div 8)) \div 4) - 1 \\ &= ((0 + (320 \text{ pixels} \times 8 \text{ bpp} \div 8)) \div 4) - 1 \end{aligned}$$

= 79 (4Fh)

### Line Address Offset

The Main Window Line Address Offset register (REG[78h], REG[79h]) is based on the display width and programmed using the following formula.

Main Window Line Address Offset bits 9-0  
 = Display width in pixels ÷ (32 ÷ bpp)  
 = 320 pixels ÷ (32 ÷ 8 bpp)  
 = 80 (50h)

## 18.2 180° Display Rotate Mode

The following figure shows how the programmer sees a 480x320 landscape image and how the image is being displayed. The application image is written to the SSD1906 in the following sense: A–B–C–D. The display is refreshed by the SSD1906 in the following sense: D–C–B–A.

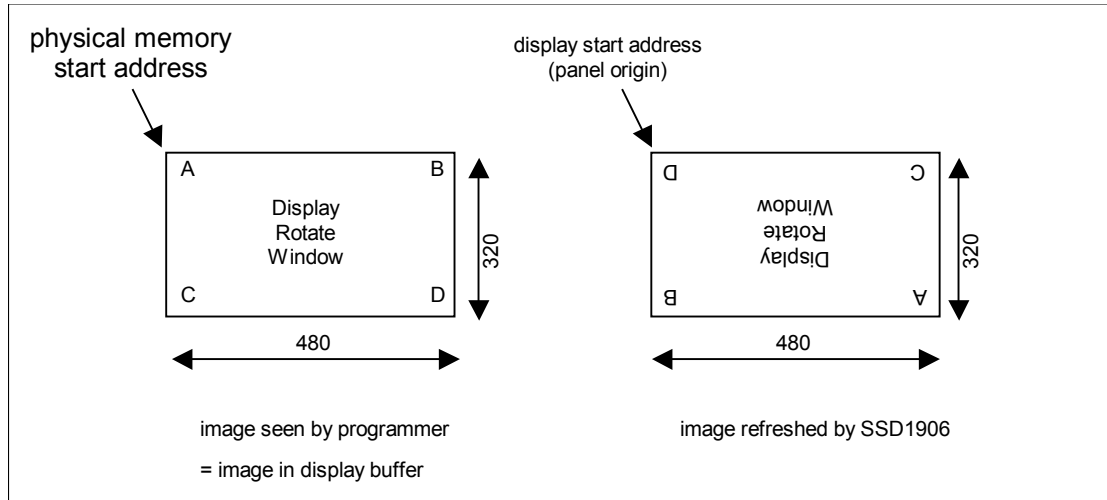

Figure 18-2 : Relationship Between The Screen Image and the Image Refreshed in 180° Display Rotate Mode.

### 18.2.1 Register Programming

#### Enable 180° Display Rotate Mode

Set Display Rotate Mode Select bits to 10 (REG[71h] bits 1:0 = 10).

#### Display Start Address

The display refresh circuitry starts at pixel “D”, therefore the Main Window Display Start Address registers (REG[74h], REG[75h], REG[76h]) must be programmed with the address of pixel “D”.

To calculate the value of the address of pixel “D” use the following formula (assumes 8bpp color depth).

Main Window Display Start Address bits 16-0  
 = ((Image address + (image width x (panel height – 1) + panel width) x bpp ÷ 8) ÷ 4) – 1  
 = ((0 + (480 pixels x 319 pixels + 480 pixels) x 8 bpp ÷ 8) ÷ 4) – 1  
 = 38399 (95FFh)

### Line Address Offset

The Main Window Line Address Offset register (REG[78h], REG[79h]) is based on the display width and programmed using the following formula.

$$\begin{aligned} & \text{Main Window Line Address Offset bits 9-0} \\ & = \text{Display width in pixels} \div (32 \div \text{bpp}) \\ & = 480 \text{ pixels} \div (32 \div 8 \text{ bpp}) \\ & = 120 \text{ (78h)} \end{aligned}$$

## 18.3 270° Display Rotate Mode

The following figure shows how the programmer sees a 320x480 rotated image and how the image is being displayed. The application image is written to the SSD1906 in the following sense: A–B–C–D. The display is refreshed by the SSD1906 in the following sense: C–A–D–B.

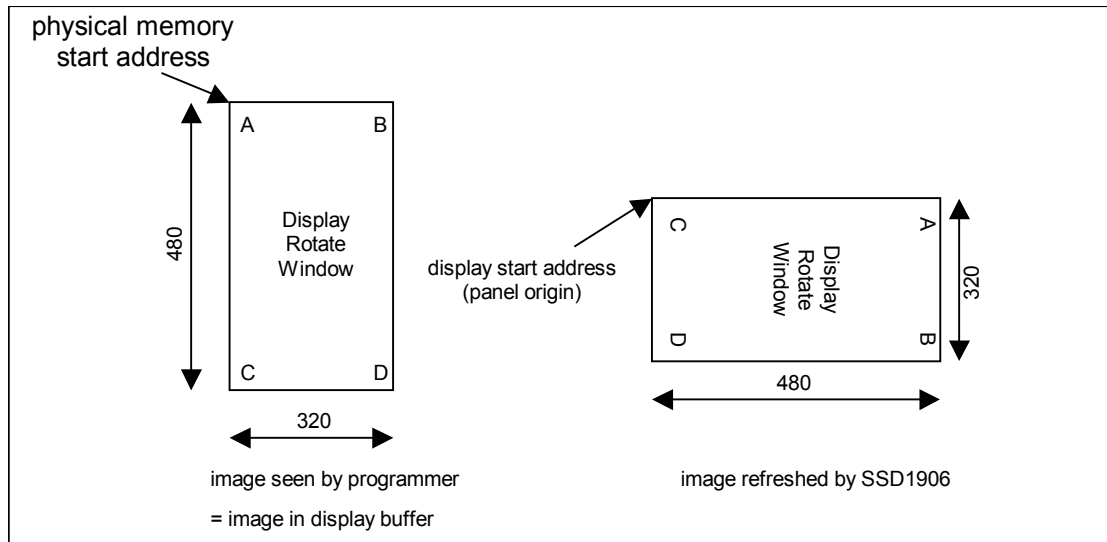

Figure 18-3 : Relationship Between The Screen Image and the Image Refreshed in 270° Display Rotate Mode.

### 18.3.1 Register Programming

#### Enable 270° Display Rotate Mode

Set Display Rotate Mode Select bits to 11 (REG[71h] bits 1:0 = 11).

#### Display Start Address

The display refresh circuitry starts at pixel "C", therefore the Main Window Display Start Address registers (REG[74h], REG[75h], REG[76h]) must be programmed with the address of pixel "C".

To calculate the value of the address of pixel "C" use the following formula (assumes 8bpp color depth).

$$\begin{aligned} & \text{Main Window Display Start Address bits 16-0} \\ & = (\text{Image address} + ((\text{panel width} - 1) \times \text{image width} \times \text{bpp} \div 8) \div 4) \\ & = (0 + ((480 \text{ pixels} - 1) \times 320 \text{ pixels} \times 8 \text{ bpp} \div 8) \div 4) \end{aligned}$$

= 38320 (95B0h)

### Line Address Offset

The Main Window Line Address Offset register (REG[78h], REG[79h]) is based on the display width and programmed using the following formula.

Main Window Line Address Offset bits 9-0

= Display width in pixels ÷ (32 ÷ bpp)

= 320 pixels ÷ (32 ÷ 8 bpp)

= 80 (50h)

## 19 Floating Window Mode

This mode enables a floating window within the main display window. The floating window can be positioned anywhere within the virtual display and is controlled through the Floating Window control registers (REG[7Ch] through REG[91h]). The floating window retains the same color depth and display orientation as the main window.

The following diagram shows an example of a floating window within a main window and the registers used to position it.

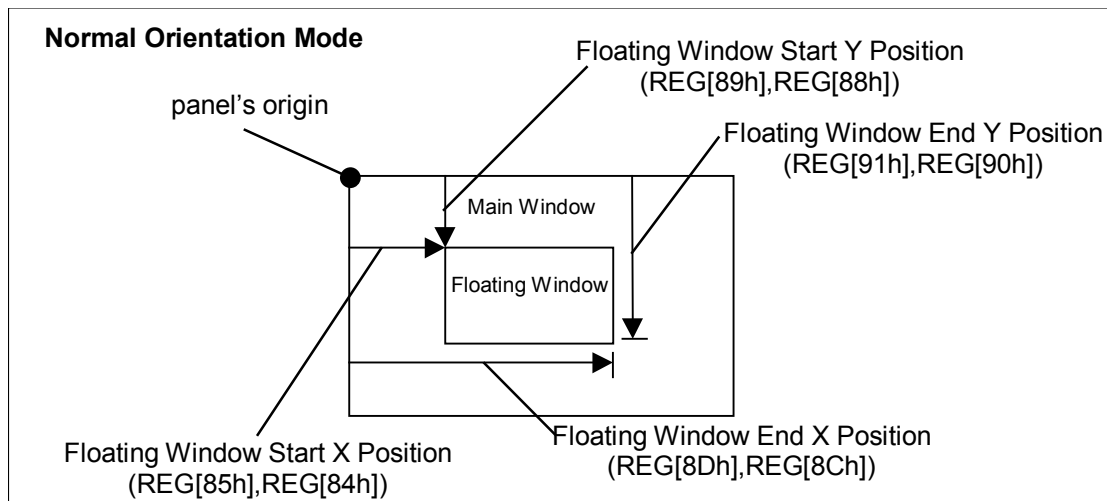

Figure 19-1 : Floating Window with Display Rotate Mode disabled

## 19.1 With Display Rotate Mode Enabled

### 19.1.1 Display Rotate Mode 90°

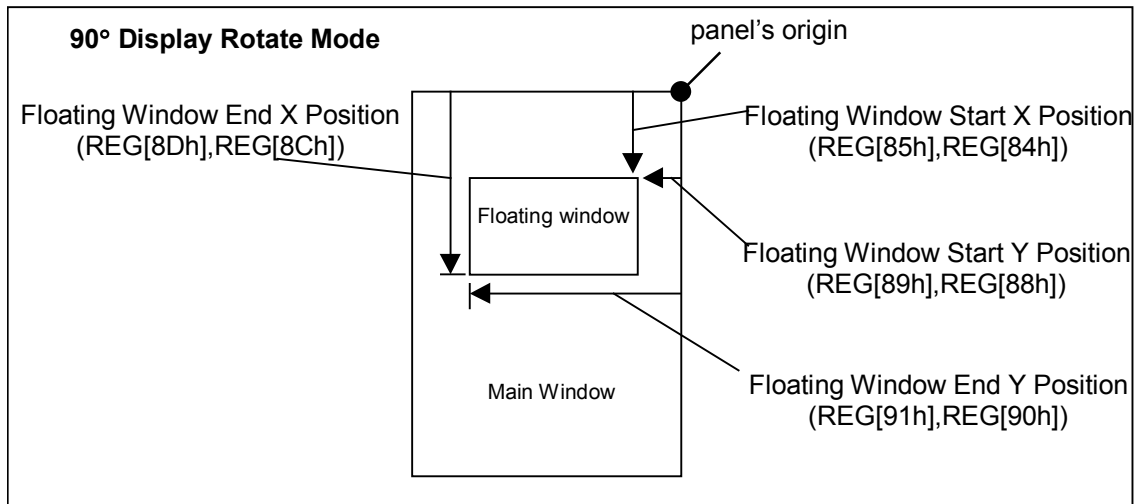

Figure 19-2 : Floating Window with Display Rotate Mode 90° enabled

### 19.1.2 Display Rotate Mode 180°

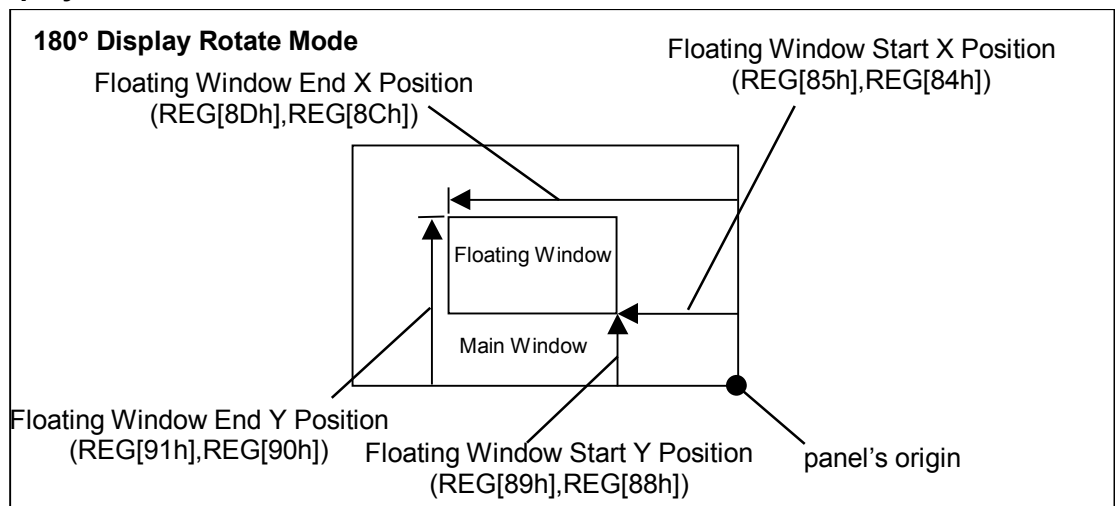

Figure 19-3 : Floating Window with Display Rotate Mode 180° enabled

### 19.1.3 Display Rotate Mode 270°

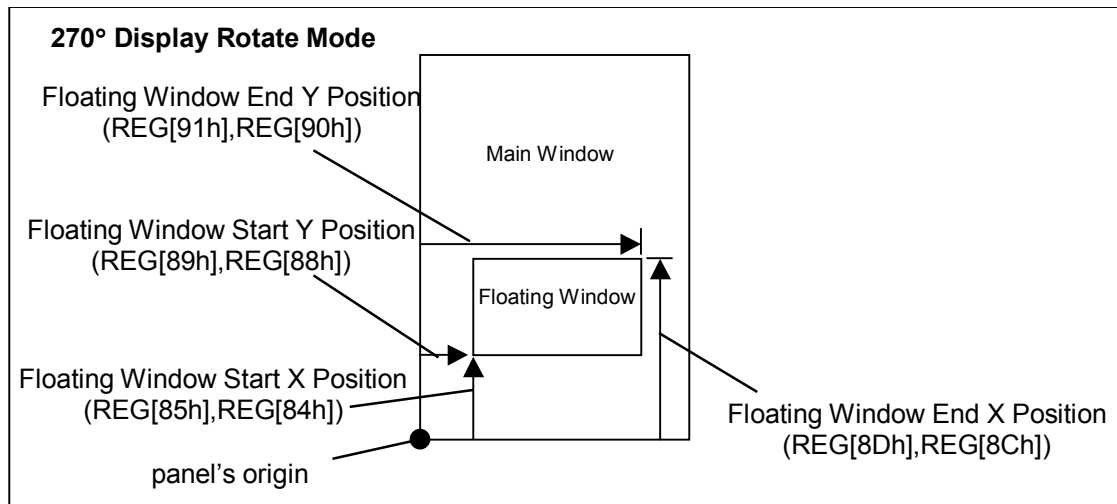

Figure 19-4 : Floating Window with Display Rotate Mode 270° enabled

## 20 Hardware Cursor Mode

This mode enables two cursors on the main display window. The cursors can be positioned anywhere within the display and are controlled through Cursor Mode registers (REG[C0h] through REG[111h]). Cursor support is available only at 4/8/16-bpp display modes.

Each cursor pixel is 2-bit and the indexing scheme is as follows:

**Table 20-1 : Indexing scheme for Hardware Cursor**

Value	Color of Cursor 1 / Cursor 2	
00	Transparent	
01	Content of color index 1 register	(REG[E1h], REG[E0h] / REG[109h], REG[108h])
10	Content of color index 2 register	(REG[E5h], REG[E4h] / REG[10Dh], REG[10Ch])
11	Content of color index 3 register	(REG[E9h], REG[E8h] / REG[111h], REG[110h])

Three 16-bit color index registers (REG[E0h] through REG[E9h] and REG[108h] through REG[111h]) have been implemented for each cursor. Only the lower portion of the color index register is used in 4/8-bpp display modes. The LUT is bypassed and the color data is directly mapped for 16-bpp display mode.

4 Bit-per-pixel

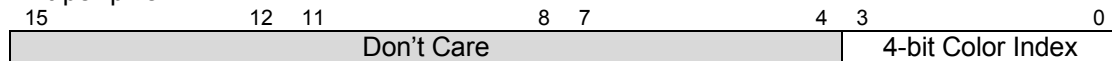

8 Bit-per-pixel

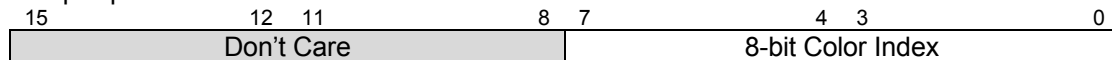

16 Bit-per-pixel (the index registers represents the 16-bit color component)

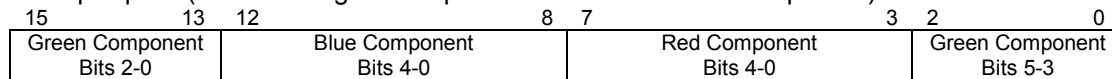

The display precedence is Cursor1 > Cursor2 > Floating window > Main Window.

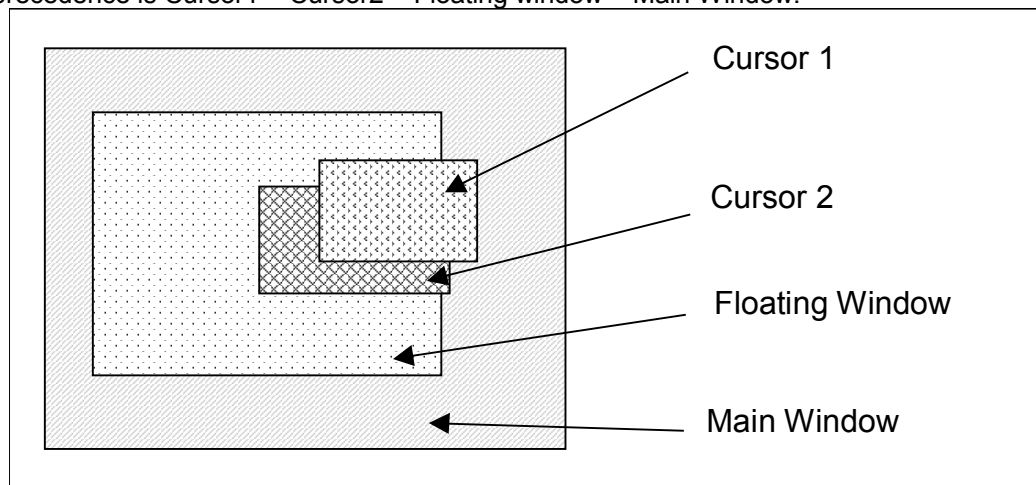
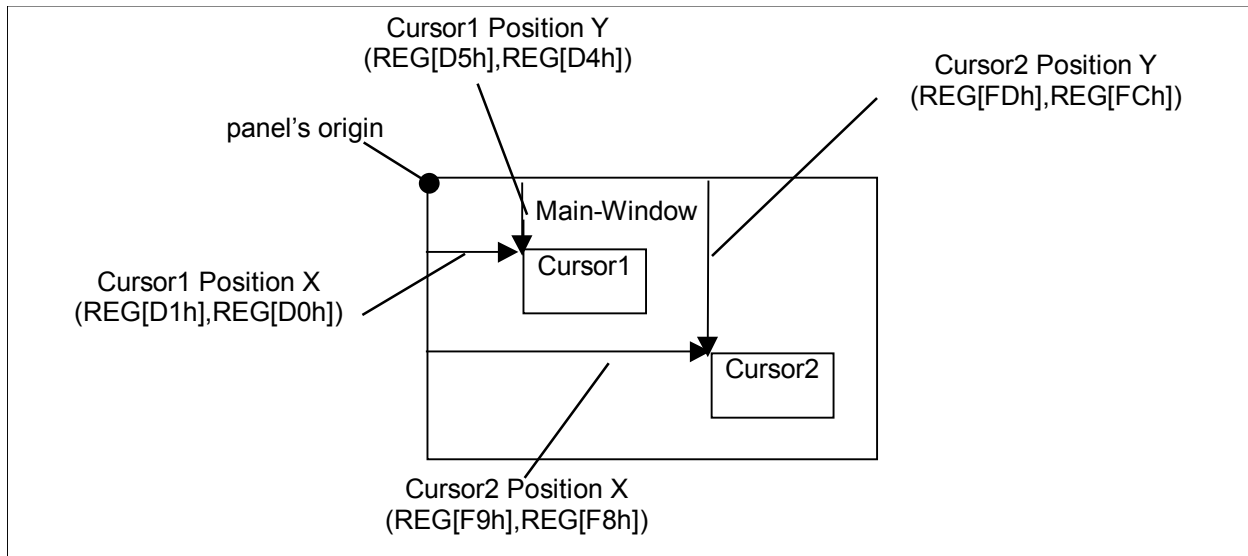

**Figure 20-1 : Display Precedence in Hardware Cursor**

**Note :**

The minimum size varies for different color depths and display orientations.

The cursors retains the same color depth and display orientation as the main window. The following diagram shows an example of two cursors within a main window and the registers used to position it.



**Figure 20-2 : Cursors on the main window**

## 20.1 With Display Rotate Mode Enabled

### 20.1.1 Display Rotate Mode 90°

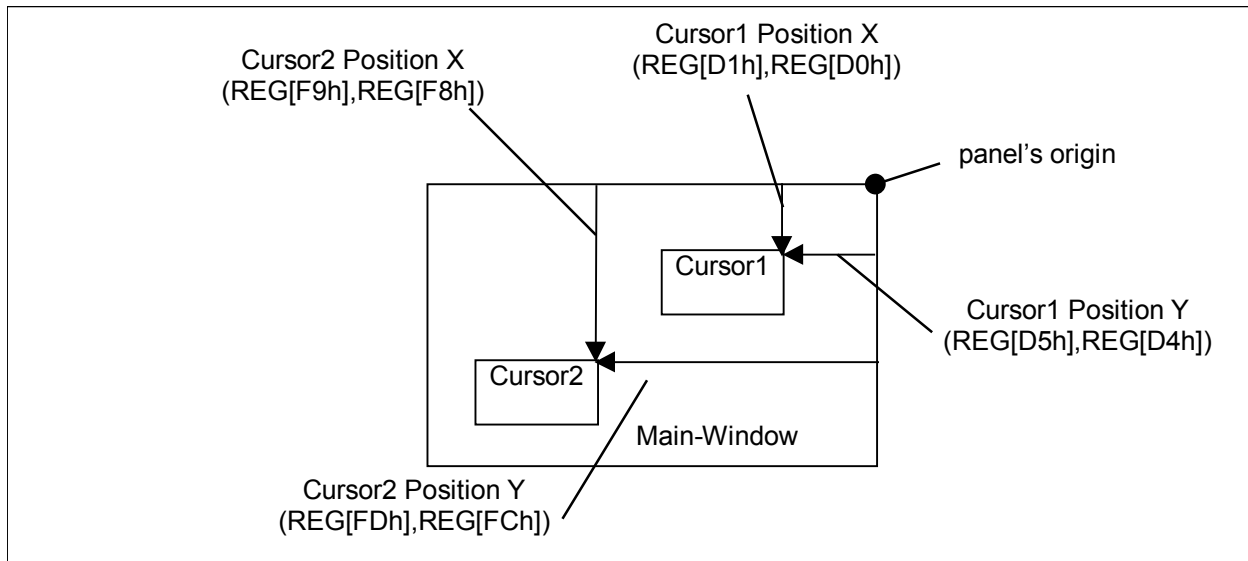

**Figure 20-3 : Cursors with Display Rotate Mode 90° enabled**



### 20.1.2 Display Rotate Mode 180°

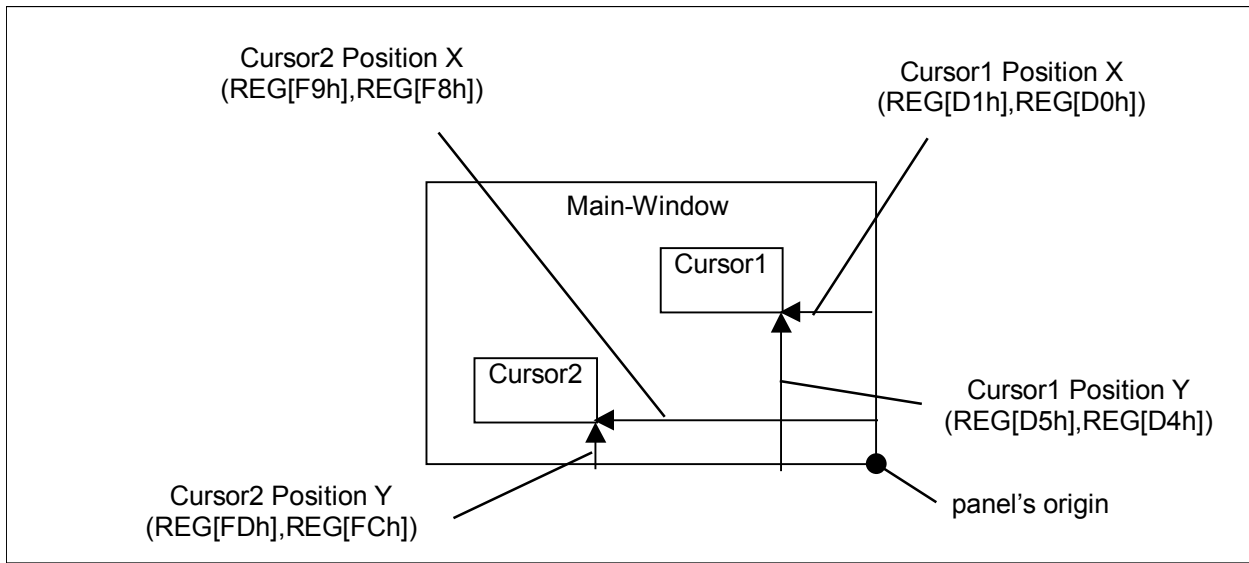

Figure 20-4 : Cursors with Display Rotate Mode 180° enabled

### 20.1.3 Display Rotate Mode 270°

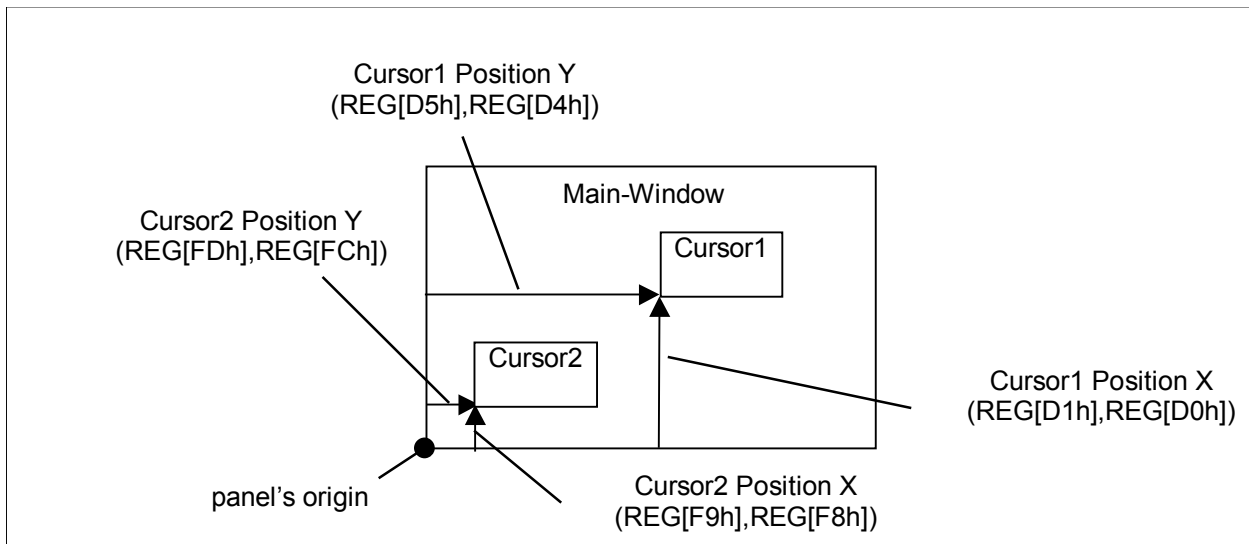

Figure 20-5 : Cursors with Display Rotate Mode 270° enabled

## 20.2 Pixel format (Normal orientation mode)

Assume the pixel data stores start at address  $n$ , which  $n$  must be divisible by 4 (i.e. aligned to 32-bit boundary). In this example, a 16x16 cursor is displayed which each cursor index is defined by  $x$  and  $y$  coordinate,  $C(y,x)$ .

### 20.2.1 4/8/16 Bit-per-pixel

	7	6	5	4	3	2	1	0
Addr. n	C(0,0)		C(0,1)		C(0,2)		C(0,3)	
Addr. n + 1	C(0,4)		C(0,5)		C(0,6)		C(0,7)	
Addr. n + 2	C(0,8)		C(0,9)		C(0,10)		C(0,11)	
Addr. n + 3	C(0,12)		C(0,13)		C(0,14)		C(0,15)	
Addr. n + 4	C(1,0)		C(1,1)		C(1,2)		C(1,3)	
Addr. n + 60	C(15,0)		C(15,1)		C(15,2)		C(15,3)	
Addr. n + 61	C(15,4)		C(15,5)		C(15,6)		C(15,7)	
Addr. n + 62	C(15,8)		C(15,9)		C(15,10)		C(15,11)	
Addr. n + 63	C(15,12)		C(15,13)		C(15,14)		C(15,15)	

### 20.3 Pixel format (90° Display Rotate Mode)

Assume the pixel data stores start at address n, which n must be divisible by 4 (i.e. aligned to 32-bit boundary). In this example, a 16x16 cursor is displayed which each cursor index is defined x and y coordinate, C(y,x).

#### 20.3.1 4 Bit-per-pixel

	7	6	5	4	3	2	1	0
Addr. n	C(0,8)		C(0,9)		C(0,10)		C(0,11)	
Addr. n + 1	C(0,12)		C(0,13)		C(0,14)		C(0,15)	
Addr. n + 2	C(1,8)		C(1,9)		C(1,10)		C(1,11)	
Addr. n + 3	C(1,12)		C(1,13)		C(1,14)		C(1,15)	
Addr. n + 28	C(14,8)		C(14,9)		C(14,10)		C(14,11)	
Addr. n + 29	C(14,12)		C(14,13)		C(14,14)		C(14,15)	
Addr. n + 30	C(15,8)		C(15,9)		C(15,10)		C(15,11)	
Addr. n + 31	C(15,12)		C(15,13)		C(15,14)		C(15,15)	
Addr. n + 32	C(0,0)		C(0,1)		C(0,2)		C(0,3)	
Addr. n + 33	C(0,4)		C(0,5)		C(0,6)		C(0,7)	
Addr. n + 34	C(1,0)		C(1,1)		C(1,2)		C(1,3)	
Addr. n + 35	C(1,4)		C(1,5)		C(1,6)		C(1,7)	
Addr. n + 60	C(14,0)		C(14,1)		C(14,2)		C(14,3)	
Addr. n + 61	C(14,4)		C(14,5)		C(14,6)		C(14,7)	
Addr. n + 62	C(15,0)		C(15,1)		C(15,2)		C(15,3)	
Addr. n + 63	C(15,4)		C(15,5)		C(15,6)		C(15,7)	

### 20.3.2 8 Bit-per-pixel

	7	6	5	4	3	2	1	0
Addr. n	C(0,12)		C(0,13)		C(0,14)		C(0,15)	
Addr. n + 1	C(1,12)		C(1,13)		C(1,14)		C(1,15)	
Addr. n + 2	C(2,12)		C(2,13)		C(2,14)		C(2,15)	
Addr. n + 3	C(3,12)		C(3,13)		C(3,14)		C(3,15)	
Addr. n + 12	C(12,12)		C(12,13)		C(12,14)		C(12,15)	
Addr. n + 13	C(13,12)		C(13,13)		C(13,14)		C(13,15)	
Addr. n + 14	C(14,12)		C(14,13)		C(14,14)		C(14,15)	
Addr. n + 15	C(15,12)		C(15,13)		C(15,14)		C(15,15)	
Addr. n + 16	C(0,8)		C(0,9)		C(0,10)		C(0,11)	
Addr. n + 17	C(1,8)		C(1,9)		C(1,10)		C(1,11)	
Addr. n + 18	C(2,8)		C(2,9)		C(2,10)		C(2,11)	
Addr. n + 19	C(3,8)		C(3,9)		C(3,10)		C(3,11)	
Addr. n + 60	C(12,0)		C(12,1)		C(12,2)		C(12,3)	
Addr. n + 61	C(13,0)		C(13,1)		C(13,2)		C(13,3)	
Addr. n + 62	C(14,0)		C(14,1)		C(14,2)		C(14,3)	
Addr. n + 63	C(15,0)		C(15,1)		C(15,2)		C(15,3)	

### 20.3.3 16 Bit-per-pixel

	7	6	5	4	3	2	1	0
Addr. n	C(0,14)		C(0,15)		C(1,14)		C(1,15)	
Addr. n + 1	C(2,14)		C(2,15)		C(3,14)		C(3,15)	
Addr. n + 2	C(4,14)		C(4,15)		C(5,14)		C(5,15)	
Addr. n + 3	C(6,14)		C(6,15)		C(7,14)		C(7,15)	
Addr. n + 4	C(8,14)		C(8,15)		C(9,14)		C(9,15)	
Addr. n + 5	C(10,14)		C(10,15)		C(11,14)		C(11,15)	
Addr. n + 6	C(12,14)		C(12,15)		C(12,14)		C(12,15)	
Addr. n + 7	C(14,14)		C(14,15)		C(15,14)		C(15,15)	
Addr. n + 8	C(0,12)		C(0,13)		C(1,12)		C(1,13)	
Addr. n + 9	C(2,12)		C(2,13)		C(3,12)		C(3,13)	
Addr. n + 10	C(4,12)		C(4,13)		C(5,12)		C(5,13)	
Addr. n + 11	C(6,12)		C(6,13)		C(7,12)		C(7,13)	
Addr. n + 60	C(8,0)		C(8,1)		C(9,0)		C(9,1)	
Addr. n + 61	C(10,0)		C(10,1)		C(11,0)		C(11,1)	
Addr. n + 62	C(12,0)		C(12,1)		C(12,0)		C(12,1)	

Addr. n + 63	C(14,0)	C(14,1)	C(15,0)	C(15,1)
--------------	---------	---------	---------	---------

## 20.4 Pixel format (180° Display Rotate Mode)

Assume the pixel data stores start at address n, which n must be divisible by 4 (i.e. aligned to 32-bit boundary). In this example, a 16x16 cursor is displayed which each cursor index is defined by x and y coordinate, C(y,x).

### 20.4.1 4 Bit-per-pixel

	7	6	5	4	3	2	1	0
Addr. n	C(15,8)		C(15,9)		C(15,10)		C(15,11)	
Addr. n + 1	C(15,12)		C(15,13)		C(15,14)		C(15,15)	
Addr. n + 2	C(15,0)		C(15,1)		C(15,2)		C(15,3)	
Addr. n + 3	C(15,4)		C(15,5)		C(15,6)		C(15,7)	
Addr. n + 4	C(14,8)		C(14,9)		C(14,10)		C(14,11)	

▪

▪

▪

Addr. n + 60	C(0,8)		C(0,9)		C(0,10)		C(0,11)	
Addr. n + 61	C(0,12)		C(0,13)		C(0,14)		C(0,15)	
Addr. n + 62	C(0,0)		C(0,1)		C(0,2)		C(0,3)	
Addr. n + 63	C(0,4)		C(0,5)		C(0,6)		C(0,7)	

### 20.4.2 8 Bit-per-pixel

	7	6	5	4	3	2	1	0
Addr. n	C(15,12)		C(15,13)		C(15,14)		C(15,15)	
Addr. n + 1	C(15,8)		C(15,9)		C(15,10)		C(15,11)	
Addr. n + 2	C(15,4)		C(15,5)		C(15,6)		C(15,7)	
Addr. n + 3	C(15,0)		C(15,1)		C(15,2)		C(15,3)	
Addr. n + 4	C(14,12)		C(14,13)		C(14,14)		C(14,15)	

▪

▪

▪

Addr. n + 60	C(0,12)		C(0,13)		C(0,14)		C(0,15)	
Addr. n + 61	C(0,8)		C(0,9)		C(0,10)		C(0,11)	
Addr. n + 62	C(0,4)		C(0,5)		C(0,6)		C(0,7)	
Addr. n + 63	C(0,0)		C(0,1)		C(0,2)		C(0,3)	

### 20.4.3 16 Bit-per-pixel

	7	6	5	4	3	2	1	0
Addr. n	C(15,14)		C(15,15)		C(15,12)		C(15,13)	
Addr. n + 1	C(15,10)		C(15,11)		C(15,8)		C(15,9)	
Addr. n + 2	C(15,6)		C(15,7)		C(15,4)		C(15,5)	
Addr. n + 3	C(15,2)		C(15,3)		C(15,0)		C(15,1)	
Addr. n + 4	C(14,14)		C(14,15)		C(14,12)		C(14,13)	
Addr. n + 60	C(0,14)		C(0,15)		C(0,12)		C(0,13)	
Addr. n + 61	C(0,10)		C(0,11)		C(0,8)		C(0,9)	
Addr. n + 62	C(0,6)		C(0,7)		C(0,4)		C(0,5)	
Addr. n + 63	C(0,2)		C(0,3)		C(0,0)		C(0,1)	

## 20.5 Pixel format (270° Display Rotate Mode)

Assume the pixel data stores start at address n, which n must be divisible by 4 (i.e. aligned to 32-bit boundary). In this example, a 16x16 cursor is displayed which each cursor index is defined by x and y coordinate, C(y,x).

### 20.5.1 4 Bit-per-pixel

	7	6	5	4	3	2	1	0
Addr. n	C(15,0)		C(15,1)		C(15,2)		C(15,3)	
Addr. n + 1	C(15,4)		C(15,5)		C(15,6)		C(15,7)	
Addr. n + 2	C(14,0)		C(14,1)		C(14,2)		C(14,3)	
Addr. n + 3	C(14,4)		C(14,5)		C(14,6)		C(14,7)	
Addr. n + 28	C(1,0)		C(1,1)		C(1,2)		C(1,3)	
Addr. n + 29	C(1,4)		C(1,5)		C(1,6)		C(1,7)	
Addr. n + 30	C(0,0)		C(0,1)		C(0,2)		C(0,3)	
Addr. n + 31	C(0,4)		C(0,5)		C(0,6)		C(0,7)	
Addr. n + 32	C(15,8)		C(15,9)		C(15,10)		C(15,11)	
Addr. n + 33	C(15,12)		C(15,13)		C(15,14)		C(15,15)	
Addr. n + 34	C(14,8)		C(14,9)		C(14,10)		C(14,11)	
Addr. n + 35	C(14,12)		C(14,13)		C(14,14)		C(14,15)	
Addr. n + 60	C(1,8)		C(1,9)		C(1,10)		C(1,11)	
Addr. n + 61	C(1,12)		C(1,13)		C(1,14)		C(1,15)	
Addr. n + 62	C(0,8)		C(0,9)		C(0,10)		C(0,11)	

Addr. n + 63	C(0,12)	C(0,13)	C(0,14)	C(0,15)
--------------	---------	---------	---------	---------

### 20.5.2 8 Bit-per-pixel

	7	6	5	4	3	2	1	0
Addr. n	C(15,0)	C(15,1)	C(15,2)	C(15,3)	C(15,4)	C(15,5)	C(15,6)	C(15,7)
Addr. n + 1	C(14,0)	C(14,1)	C(14,2)	C(14,3)	C(14,4)	C(14,5)	C(14,6)	C(14,7)
Addr. n + 2	C(13,0)	C(13,1)	C(13,2)	C(13,3)	C(13,4)	C(13,5)	C(13,6)	C(13,7)
Addr. n + 3	C(12,0)	C(12,1)	C(12,2)	C(12,3)	C(12,4)	C(12,5)	C(12,6)	C(12,7)

▪

▪

▪

Addr. n + 12	C(3,0)	C(3,1)	C(3,2)	C(3,3)
Addr. n + 13	C(2,0)	C(2,1)	C(2,2)	C(2,3)
Addr. n + 14	C(1,0)	C(1,1)	C(1,2)	C(1,3)
Addr. n + 15	C(0,0)	C(0,1)	C(0,2)	C(0,3)
Addr. n + 16	C(15,4)	C(15,5)	C(15,6)	C(15,7)
Addr. n + 17	C(14,4)	C(14,5)	C(14,6)	C(14,7)
Addr. n + 18	C(13,4)	C(13,5)	C(13,6)	C(13,7)
Addr. n + 19	C(12,4)	C(12,5)	C(12,6)	C(12,7)

▪

▪

▪

Addr. n + 60	C(3,12)	C(3,13)	C(3,14)	C(3,15)
Addr. n + 61	C(2,12)	C(2,13)	C(2,14)	C(2,15)
Addr. n + 62	C(1,12)	C(1,13)	C(1,14)	C(1,15)
Addr. n + 63	C(0,12)	C(0,13)	C(0,14)	C(0,15)

### 20.5.3 16 Bit-per-pixel

	7	6	5	4	3	2	1	0
Addr. n	C(15,0)	C(15,1)	C(14,0)	C(14,1)	C(13,0)	C(13,1)	C(12,0)	C(12,1)
Addr. n + 1	C(13,0)	C(13,1)	C(12,0)	C(12,1)	C(11,0)	C(11,1)	C(10,0)	C(10,1)
Addr. n + 2	C(11,0)	C(11,1)	C(10,0)	C(10,1)	C(9,0)	C(9,1)	C(8,0)	C(8,1)
Addr. n + 3	C(9,0)	C(9,1)	C(8,0)	C(8,1)	C(7,0)	C(7,1)	C(6,0)	C(6,1)
Addr. n + 4	C(7,0)	C(7,1)	C(6,0)	C(6,1)	C(5,0)	C(5,1)	C(4,0)	C(4,1)
Addr. n + 5	C(5,0)	C(5,1)	C(4,0)	C(4,1)	C(3,0)	C(3,1)	C(2,0)	C(2,1)
Addr. n + 6	C(3,0)	C(3,1)	C(2,0)	C(2,1)	C(1,0)	C(1,1)	C(0,0)	C(0,1)
Addr. n + 7	C(1,0)	C(1,1)	C(0,0)	C(0,1)	C(15,2)	C(15,3)	C(14,2)	C(14,3)
Addr. n + 8	C(15,2)	C(15,3)	C(14,2)	C(14,3)	C(13,2)	C(13,3)	C(12,2)	C(12,3)
Addr. n + 9	C(13,2)	C(13,3)	C(12,2)	C(12,3)	C(11,2)	C(11,3)	C(10,2)	C(10,3)
Addr. n + 10	C(11,2)	C(11,3)	C(10,2)	C(10,3)	C(9,2)	C(9,3)	C(8,2)	C(8,3)
Addr. n + 11	C(9,2)	C(9,3)	C(8,2)	C(8,3)				

▪

▪

▪

Addr. n + 60	C(7,14)	C(7,15)	C(6,14)	C(6,15)
Addr. n + 61	C(5,14)	C(5,15)	C(4,14)	C(4,15)
Addr. n + 62	C(3,14)	C(3,15)	C(2,14)	C(2,15)

Addr. n + 63	C(1,14)	C(1,15)	C(0,14)	C(0,15)
--------------	---------	---------	---------	---------

## 21 APPLICATION EXAMPLES

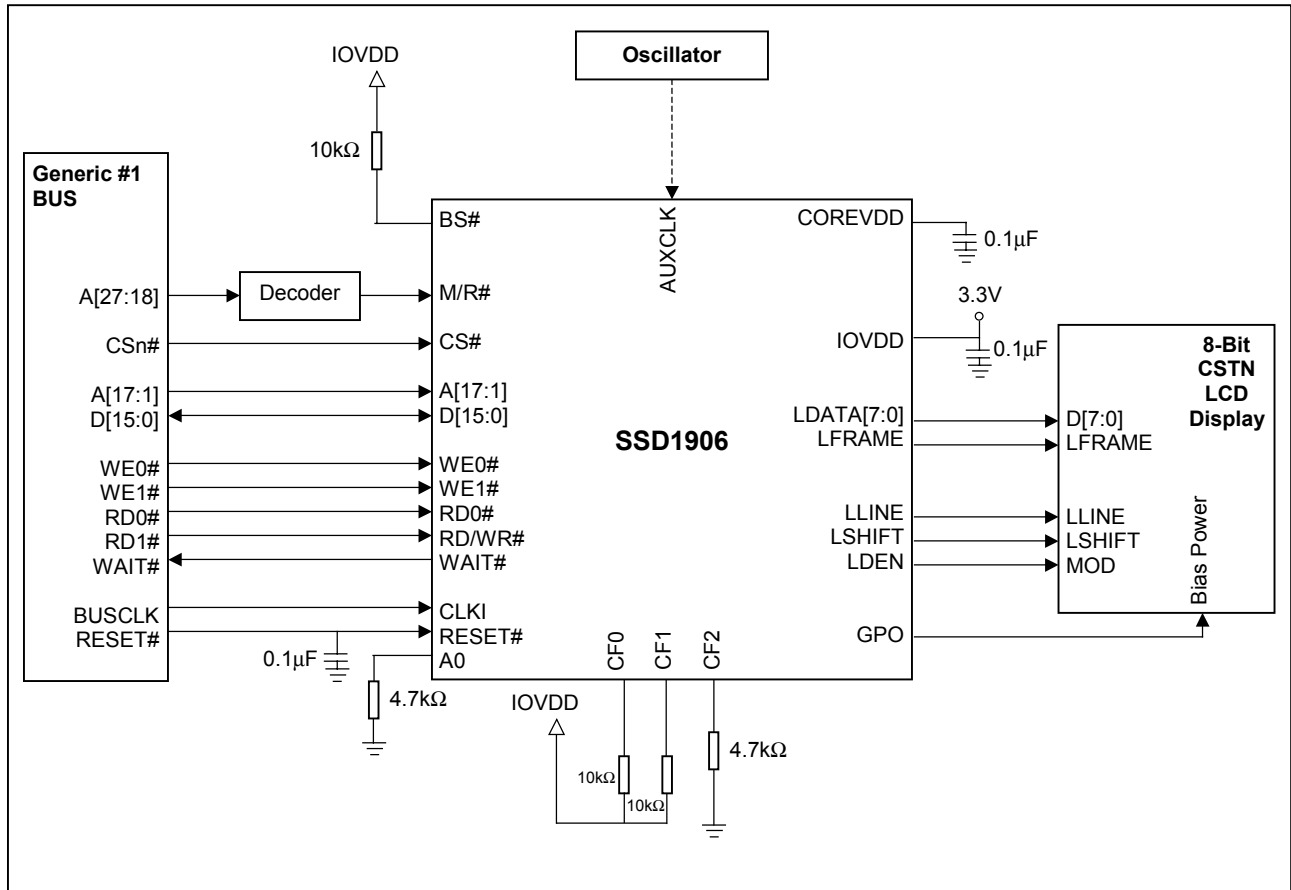

Figure 21-1: Typical System Diagram (Generic #1 Bus)



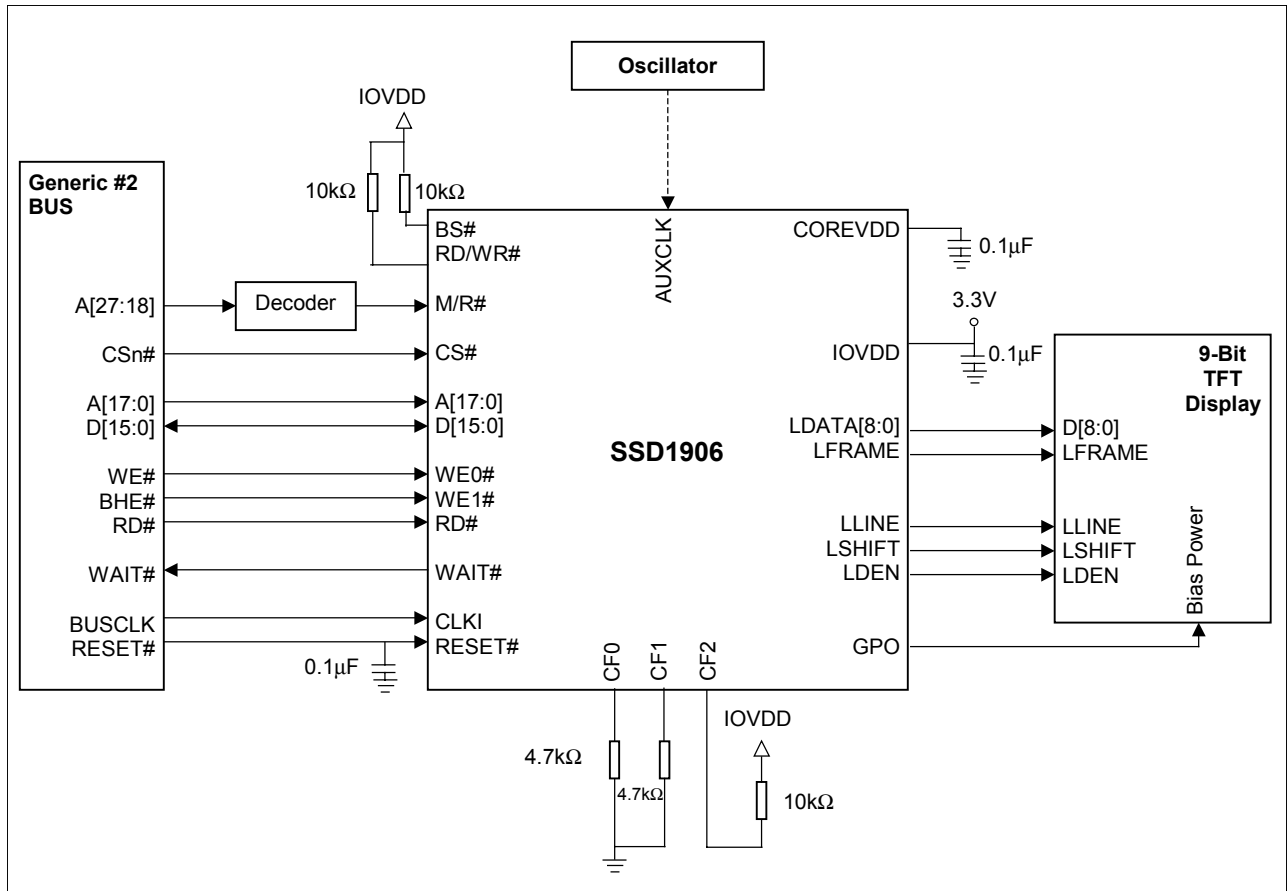

Figure 21-2 : Typical System Diagram (Generic #2 Bus)

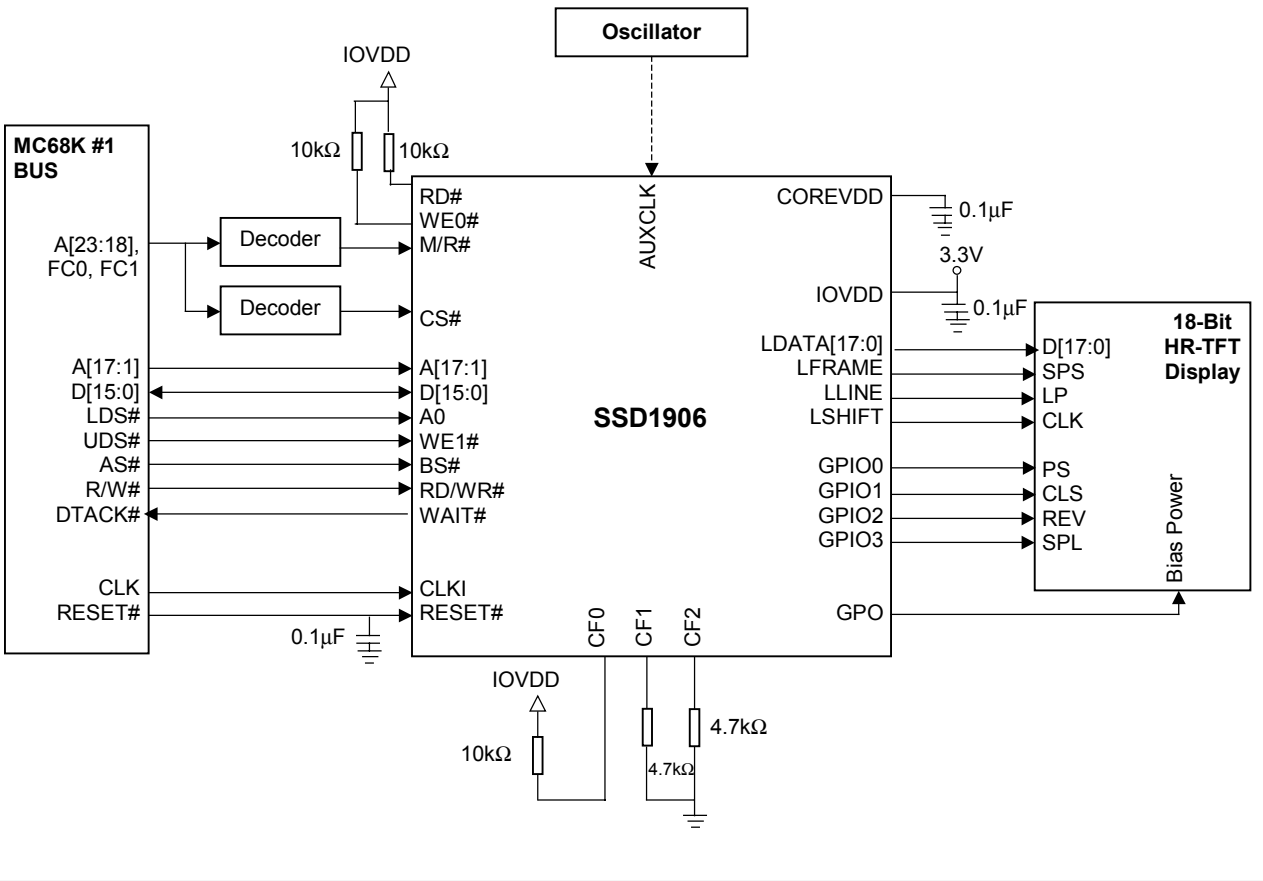

Figure 21-3 : Typical System Diagram (MC68K # 1, Motorola 16-Bit 68000)

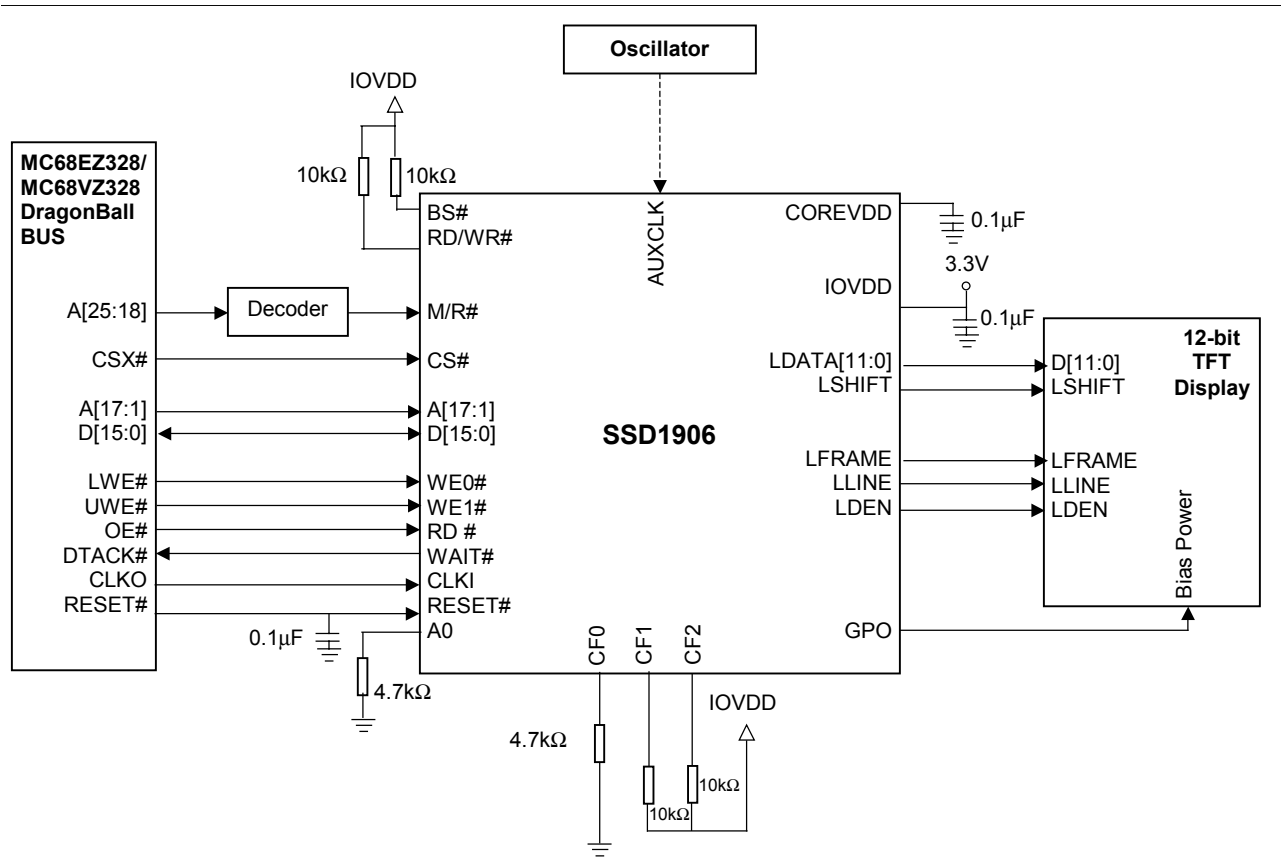

Figure 21-4 : Typical System Diagram (Motorola MC68EZ328/MC68VZ328 “DragonBall” Bus)

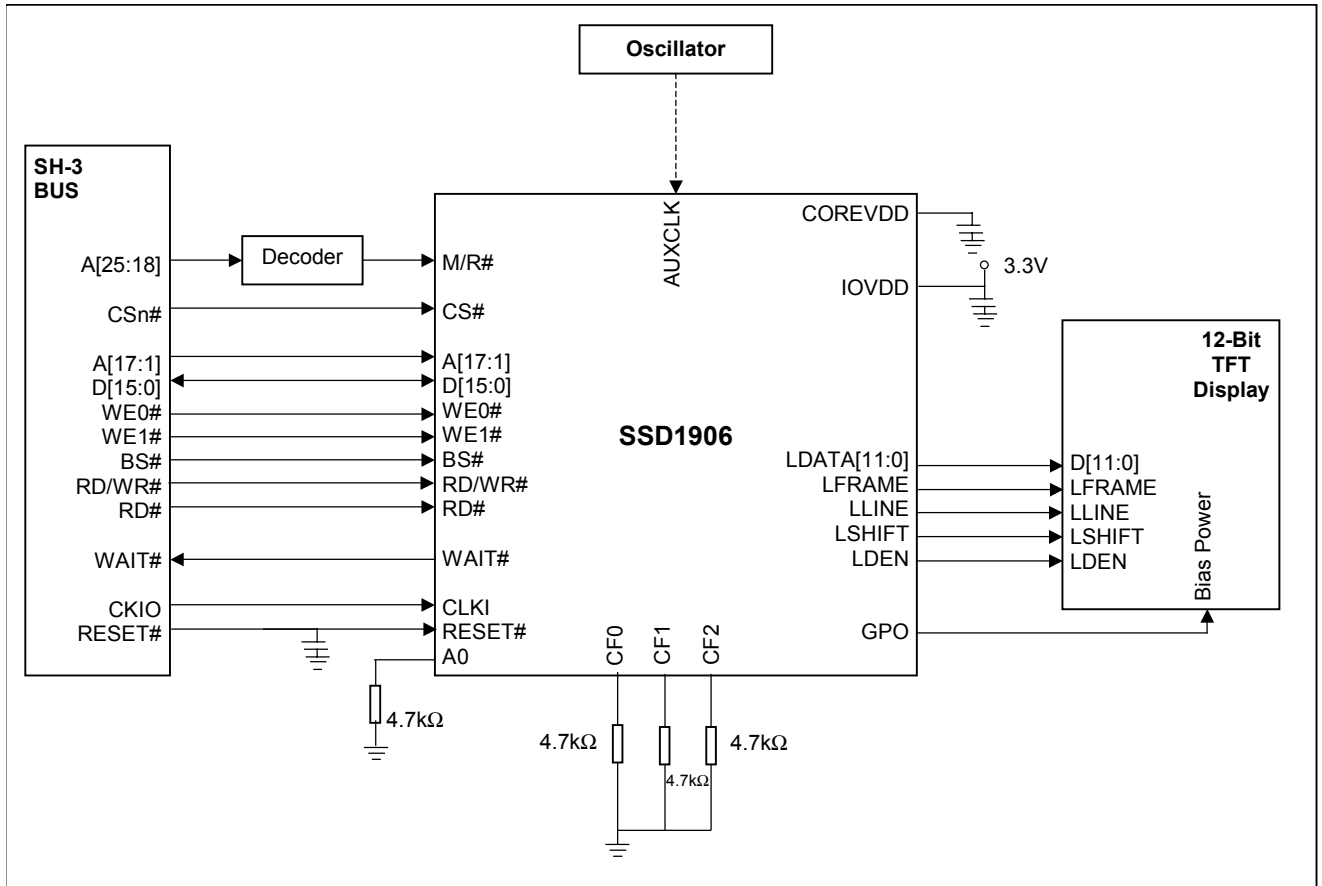

Figure 21-5 : Typical System Diagram (Hitachi SH-3 Bus)

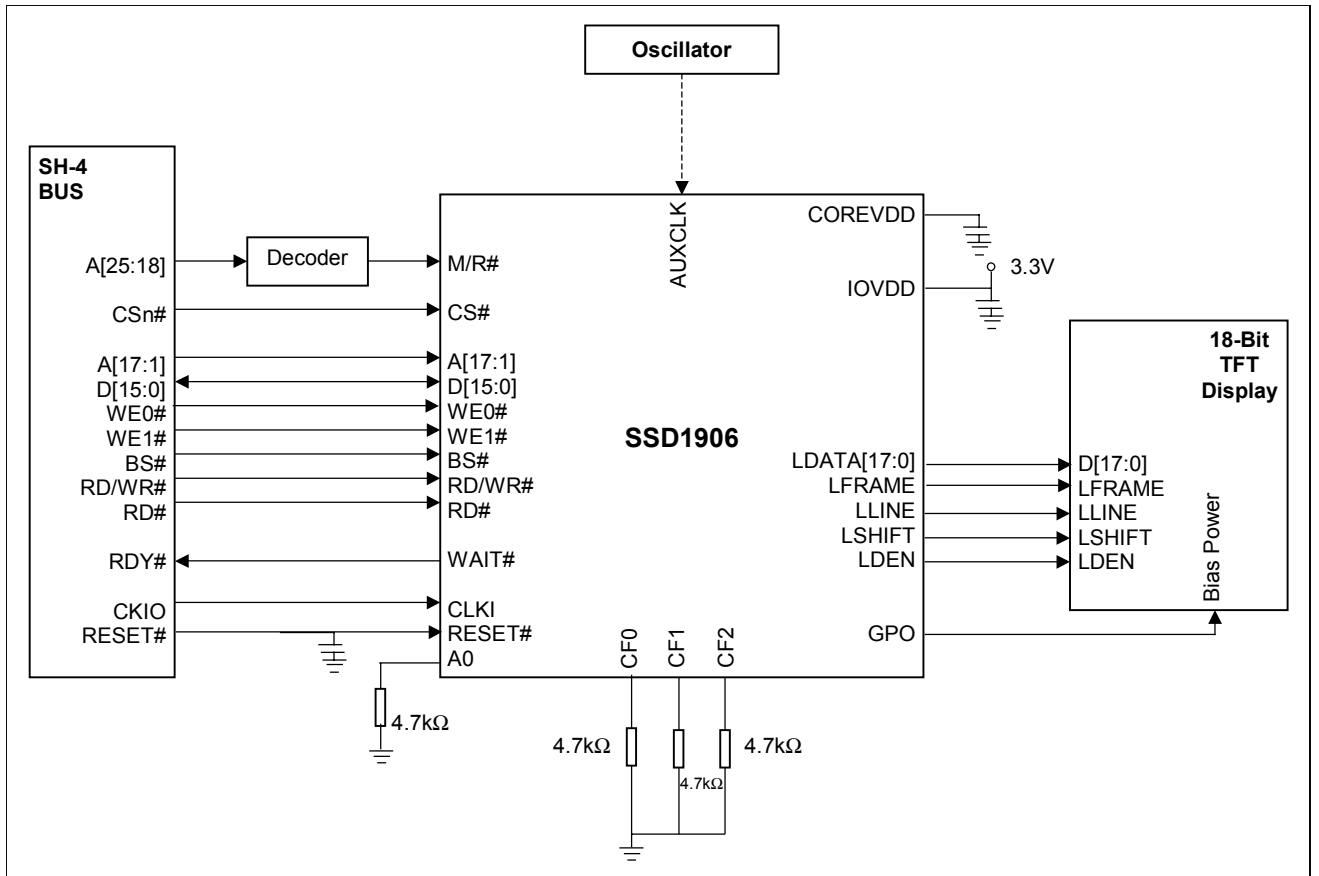
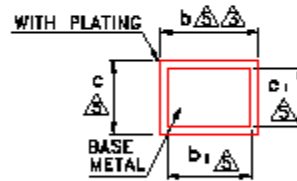
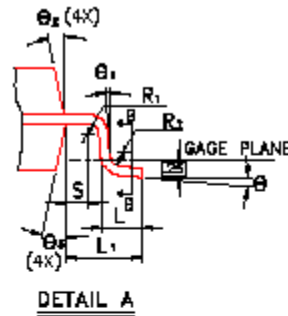
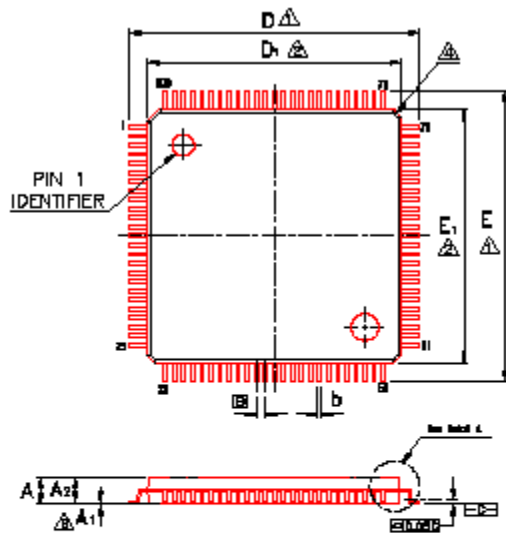

Figure 21-6 : Typical System Diagram (Hitachi SH-4 Bus)

## 22 APPENDIX

### 22.1 Package Mechanical Drawing for 100 pins TQFP



NOTE :

- △ TO BE DETERMINED AT SEATING PLANE □□□ .
- △ DIMENSIONS D1 AND E1 DO NOT INCLUDE MOLD PROTRUSION. D1 AND E1 ARE MAXIMUM PLASTIC BODY SIZE DIMENSIONS INCLUDING MOLD MISMATCH.
- △ DIMENSION b DOES NOT INCLUDE DAMBAR PROTRUSION. DAMBAR CAN NOT BE LOCATED ON THE LOWER RADIUS OR THE FOOT. EXACT SHAPE OF EACH CORNER IS OPTIONAL.
- △ THESE DIMENSIONS APPLY TO THE FLAT SECTION OF THE LEAD BETWEEN 0.10 mm AND 0.25 mm FROM THE LEAD TIP.
- △ A1 IS DEFINED AS THE DISTANCE FROM THE SEATING PLANE TO THE LOWEST POINT OF THE PACKAGE BODY.
- 7. CONTROLLING DIMENSION : MILLIMETER.
- 8. REFERENCE DOCUMENT : JEDEC MS-026 , BSC.

Symbol	Dimension In mm			Dimension In Inch		
	Min	Nom	Max	Min	Nom	Max
A	—	—	1.20	—	—	0.047
A <sub>1</sub>	0.05	—	0.15	0.002	—	0.008
A <sub>2</sub>	0.95	1.00	1.05	0.037	0.039	0.041
b	0.17	0.22	0.27	0.007	0.009	0.011
b <sub>1</sub>	0.17	0.20	0.23	0.007	0.008	0.009
c	0.08	—	0.20	0.004	—	0.008
c <sub>1</sub>	0.09	—	0.18	0.004	—	0.030
D	16.00 BSC			0.630 BSC		
D <sub>1</sub>	14.00 BSC			0.551 BSC		
E	16.00 BSC			0.630 BSC		
E <sub>1</sub>	14.00 BSC			0.551 BSC		
□	0.50 BSC			0.020 BSC		
L	0.45	0.60	0.75	0.018	0.024	0.030
L <sub>1</sub>	1.00 REF			0.039 REF		
R <sub>1</sub>	0.08	—	—	0.003	—	—
R <sub>2</sub>	0.08	—	0.20	0.003	—	0.008
S	0.20	—	—	0.008	—	—
θ	0°	3.5°	7°	0°	3.5°	7°
θ <sub>1</sub>	0°	—	—	0°	—	—
θ <sub>2</sub>	11°	12°	13°	11°	12°	13°
θ <sub>3</sub>	11°	12°	13°	11°	12°	13°

## 22.2 Package Mechanical Drawing for 100 pins TFBGA

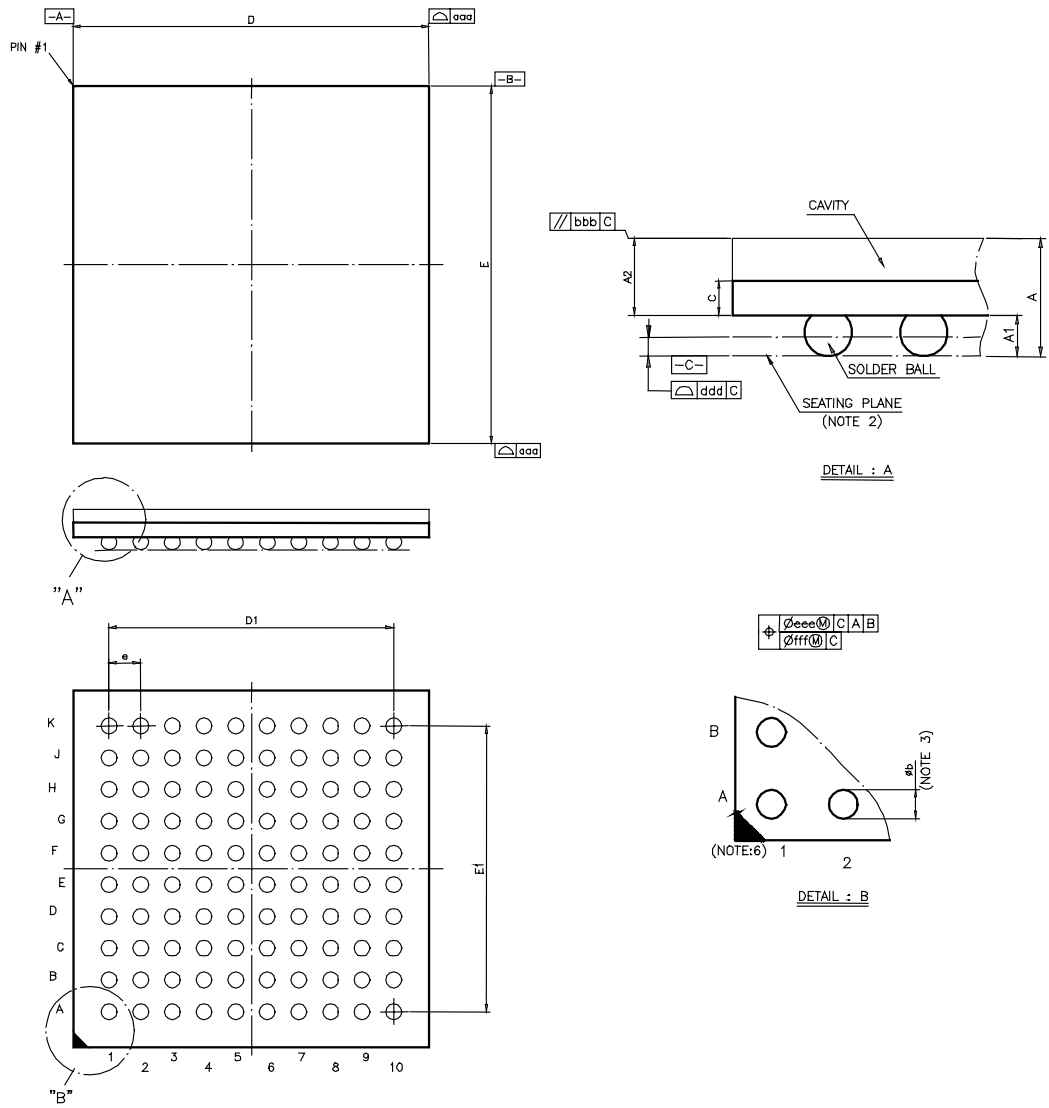

Symbol	Dimension in mm			Dimension in inch		
	MIN	NOM	MAX	MIN	NOM	MAX
A	----	----	1.40	----	----	0.055
A1	0.25	0.30	0.35	0.010	0.012	0.014
A2	0.81	0.89	0.97	0.032	0.035	0.038
c	----	0.36	----	----	0.014	----
D	8.90	9.00	9.10	0.350	0.354	0.358
E	8.90	9.00	9.10	0.350	0.354	0.358
D1	----	7.20	----	----	0.283	----
E1	----	7.20	----	----	0.283	----
e	----	0.80	----	----	0.031	----
b	0.35	0.40	0.45	0.014	0.016	0.018
aaa	----	----	0.10	----	----	0.004
bbb	----	----	0.10	----	----	0.004
ddd	----	----	0.12	----	----	0.005
eee	----	----	0.15	----	----	0.006
fff	----	----	0.08	----	----	0.003
MD/ME	10/10			10/10		

NOTE :

1. CONTROLLING DIMENSION : MILLIMETER.
2. PRIMARY DATUM C AND SEATING PLANE ARE DEFINED BY THE SPHERICAL CROWNS OF THE SOLDER BALLS.
3. DIMENSION b IS MEASURED AT THE MAXIMUM SOLDER BALL DIAMETER, PARALLEL TO PRIMARY DATUM C.
4. THERE SHALL BE A MINIMUM CLEARANCE OF 0.25mm BETWEEN THE EDGE OF THE SOLDER BALL AND THE BODY EDGE.
5. REFERENCE DOCUMENT : JEDEC MO-205 .
6. THE PATTERN OF PIN 1 FIDUCIAL IS FOR REFERENCE ONLY .



## 22.3 Register Table

Table 22-1 : SSD1906 Register Table (1 of 3)

Register	Pg
<b>Read-Only Configuration Registers</b>	
REG[01h] Display Buffer Size Register	19
REG[02h] Configuration Readback Register	19
REG[03h] Product / Revision Code Register	20
<b>Clock Configuration Registers</b>	
REG[04h] Memory Clock Configuration Register	20
REG[05h] Pixel Clock Configuration Register	20
<b>Look-Up Table Registers</b>	
REG[08h] Look-Up Table Blue Write Data Register	21
REG[09h] Look-Up Table Green Write Data Register	22
REG[0Ah] Look-Up Table Red Write Data Register	22
REG[0Bh] Look-Up Table Write Address Register	23
REG[0Ch] Look-Up Table Blue Read Data Register	23
REG[0Dh] Look-Up Table Green Read Data Register	23
REG[0Eh] Look-Up Table Red Read Data Register	24
REG[0Fh] Look-Up Table Read Address Register	24
<b>Panel Configuration Registers</b>	
REG[10h] Panel Type Register	25
REG[11h] MOD Rate Register	26
REG[12h] Horizontal Total Register	26
REG[14h] Horizontal Display Period Register	27
REG[16h] Horizontal Display Period Start Position Register 0	27
REG[17h] Horizontal Display Period Start Position Register 1	27
REG[18h] Vertical Total Register 0	27
REG[19h] Vertical Total Register 1	28
REG[1Ch] Vertical Display Period Register 0	28
REG[1Dh] Vertical Display Period Register 1	28
REG[1Eh] Vertical Display Period Start Position Register 0	29
REG[1Fh] Vertical Display Period Start Position Register 1	29
REG[20h] LLINE Pulse Width Register	29
REG[22h] LLINE Pulse Start Position Register 0	30
REG[23h] LLINE Pulse Start Position Register 1	30
REG[24h] LFRAME Pulse Width Register	30
REG[26h] LFRAME Pulse Start Position Register 0	31
REG[27h] LFRAME Pulse Start Position Register 1	31
REG[30h] LFRAME Pulse Start Offset Register 0	31
REG[31h] LFRAME Pulse Start Offset Register 1	31
REG[34h] LFRAME Pulse Stop Offset Register 0	32
REG[35h] LFRAME Pulse Stop Offset Register 1	32
REG[38h] HR-TFT Special Output Register	32
REG[3Ah] GPIO1 Pulse Start Register	33
REG[3Bh] GPIO1 Pulse Stop Register	33
REG[3Ch] GPIO0 Pulse Start Register	34
REG[3Eh] GPIO0 Pulse Stop Register	34
REG[40h] GPIO2 Pulse Delay Register	34
REG[45h] STN Color Depth Control Register	35
REG[50h] Dynamic Dithering Control Register	36
<b>Display Mode Registers</b>	
REG[70h] Display Mode Register	36
REG[71h] Special Effects Register	38
<b>Main Window Registers</b>	
REG[74h] Main Window Display Start Address Register 0	39
REG[75h] Main Window Display Start Address Register 1	39
REG[76h] Main Window Display Start Address Register 2	39
REG[78h] Main Window Line Address Offset Register 0	40
REG[79h] Main Window Line Address Offset Register 1	40

**Table 22-2 : SSD1906 Register Table (2 of 3)**

<b>Register</b>	<b>Pg</b>
<b>Floating Window Registers</b>	
REG[7Ch] Floating Window Display Start Address Register 0	41
REG[7Dh] Floating Window Display Start Address Register 1	41
REG[7Eh] Floating Window Display Start Address Register 2	41
REG[80h] Floating Window Line Address Offset Register 0	42
REG[81h] Floating Window Line Address Offset Register 1	42
REG[84h] Floating Window Start Position X Register 0	42
REG[85h] Floating Window Start Position X Register 1	43
REG[88h] Floating Window Start Position Y Register 0	43
REG[89h] Floating Window Start Position Y Register 1	44
REG[8Ch] Floating Window End Position X Register 0	44
REG[8Dh] Floating Window End Position X Register 1	45
REG[90h] Floating Window End Position Y Register 0	45
REG[91h] Floating Window End Position Y Register 1	46
<b>Miscellaneous Registers</b>	
REG[A0h] Power Saving Configuration Register	46
REG[A2h] Software Reset Register	47
REG[A4h] Scratch Pad Register 0	47
REG[A5h] Scratch Pad Register 1	47
REG[134h] Command Initialization Register	48
<b>General Purpose IO Pins Registers</b>	
REG[A8h] General Purpose IO Pins Configuration Register 0	48
REG[A9h] General Purpose IO Pins Configuration Register 1	49
REG[ACh] General Purpose IO Pins Status/Control Register 0	49
REG[ADh] General Purpose IO Pins Status/Control Register 1	50
<b>PWM Clock and CV Pulse Configuration Registers</b>	
REG[B0h] PWM Clock / CV Pulse Control Register	51
REG[B1h] PWM Clock / CV Pulse Configuration Register	52
REG[B2h] CV Pulse Burst Length Register	53
REG[B3h] LPWMOUT Duty Cycle Register	53

**Table 22-3 : SSD1906 Register Table (3 of 3)**

<b>Register</b>	<b>Pg</b>
<b>Cursor Mode Registers</b>	
REG[C0h] Cursor Feature Register	54
REG[C4h] Cursor1 Blink Total Register 0	54
REG[C5h] Cursor1 Blink Total Register 1	54
REG[C8h] Cursor1 Blink On Register 0	55
REG[C9h] Cursor1 Blink On Register 1	55
REG[CCh] Cursor1 Memory Start Register 0	55
REG[CDh] Cursor1 Memory Start Register 1	55
REG[CEh] Cursor1 Memory Start Register 2	55
REG[D0h] Cursor1 Position X Register 0	56
REG[D1h] Cursor1 Position X Register 1	56
REG[D4h] Cursor1 Position Y Register 0	56
REG[D5h] Cursor1 Position Y Register 1	56
REG[D8h] Cursor1 Horizontal size Register 0	57
REG[D9h] Cursor1 Horizontal size Register 1	57
REG[DCh] Cursor1 Vertical size Register 0	58
REG[DDh] Cursor1 Vertical size Register 1	58
REG[E0h] Cursor1 Color Index1 Register 0	58
REG[E1h] Cursor1 Color Index1 Register 1	59
REG[E4h] Cursor1 Color Index2 Register 0	59
REG[E5h] Cursor1 Color Index2 Register 1	59
REG[E8h] Cursor1 Color Index3 Register 0	59
REG[E9h] Cursor1 Color Index3 Register 1	60
REG[ECh] Cursor2 Blink Total Register 0	60
REG[EDh] Cursor2 Blink Total Register 1	60
REG[F0h] Cursor2 Blink On Register 0	60
REG[F1h] Cursor2 Blink On Register 1	61
REG[F4h] Cursor2 Memory Start Register 0	61
REG[F5h] Cursor2 Memory Start Register 1	61
REG[F6h] Cursor2 Memory Start Register 2	61
REG[F8h] Cursor2 Position X Register 0	62
REG[F9h] Cursor2 Position X Register 1	62
REG[FCh] Cursor2 Position Y Register 0	62
REG[FDh] Cursor2 Position Y Register 1	62
REG[100h] Cursor2 Horizontal size Register 0	63
REG[101h] Cursor2 Horizontal size Register 1	63
REG[104h] Cursor2 Vertical size Register 0	63
REG[105h] Cursor2 Vertical size Register 1	63
REG[108h] Cursor2 Color Index1 Register 0	64
REG[109h] Cursor2 Color Index1 Register 1	64
REG[10Ch] Cursor2 Color Index2 Register 0	64
REG[10Dh] Cursor2 Color Index2 Register 1	64
REG[110h] Cursor2 Color Index3 Register 0	65
REG[111h] Cursor2 Color Index3 Register 1	65

Solomon Systech reserves the right to make changes without further notice to any products herein. Solomon Systech makes no warranty, representation or guarantee regarding the suitability of its products for any particular purpose, nor does Solomon Systech assume any liability arising out of the application or use of any product or circuit, and specifically disclaims any and all liability, including without limitation consequential or incidental damages. "Typical" parameters can and do vary in different applications. All operating parameters, including "Typicals" must be validated for each customer application by customer's technical experts. Solomon Systech does not convey any license under its patent rights nor the rights of others. Solomon Systech products are not designed, intended, or authorized for use as components in systems intended for surgical implant into the body, or other applications intended to support or sustain life, or for any other application in which the failure of the Solomon Systech product could create a situation where personal injury or death may occur. Should Buyer purchase or use Solomon Systech products for any such unintended or unauthorized application, Buyer shall indemnify and hold Solomon Systech and its offices, employees, subsidiaries, affiliates, and distributors harmless against all claims, costs, damages, and expenses, and reasonable attorney fees arising out of, directly or indirectly, any claim of personal injury or death associated with such unintended or unauthorized use, even if such claim alleges that Solomon Systech was negligent regarding the design or manufacture of the part.

<http://www.solomon-systech.com>