



# Very Low Power/Voltage CMOS SRAM 1M X 8 bit

## BS62LV8003

### FEATURES

- Wide Vcc operation voltage : 2.4V ~ 3.6V
- Very low power consumption :
  - Vcc = 3V C-grade: 20mA (Max.) operating current
  - I-grade: 25mA (Max.) operating current
  - 0.5uA (Typ.) CMOS standby current
- High speed access time :
  - 70 70ns (Max) at Vcc = 3V
  - 10 100ns (Max) at Vcc = 3V
- Automatic power down when chip is deselected
- Three state outputs and TTL compatible
- Fully static operation
- Data retention supply voltage as low as 1.5V
- Easy expansion with CE1, CE2 and OE options

### GENERAL DESCRIPTION

The BS62LV8003 is a high performance, very low power CMOS Static Random Access Memory organized as 1,048,576 words by 8 bits and operates from a wide range of 2.4V to 3.6V supply voltage. Advanced CMOS technology and circuit techniques provide both high speed and low power features with a typical CMOS standby current of 0.5uA and maximum access time of 70ns in 3V operation. Easy memory expansion is provided by an active LOW chip enable ( $\overline{CE1}$ ), an active HIGH chip enable (CE2) and active LOW output enable ( $\overline{OE}$ ) and three-state output drivers. The BS62LV8003 has an automatic power down feature, reducing the power consumption significantly when chip is deselected. The BS62LV8003 is available in 44 pin TSOP2 and 48-pin BGA type.

### PRODUCT FAMILY

PRODUCT FAMILY	OPERATING TEMPERATURE	Vcc RANGE	SPEED ( ns )	POWER DISSIPATION		PKG TYPE
				STANDBY ( IccSB1, Max )	Operating ( Icc, Max )	
				Vcc=3V	Vcc=3V	
BS62LV8003EC BS62LV8003BC	+0°C to +70°C	2.4V ~ 3.6V	70 / 100	3uA	20mA	TSOP2-44 BGA-48-0810
BS62LV8003EI BS62LV8003BI	-40°C to +85°C	2.4V ~ 3.6V	70 / 100	6uA	25mA	TSOP2-44 BGA-48-0810

### PIN CONFIGURATIONS

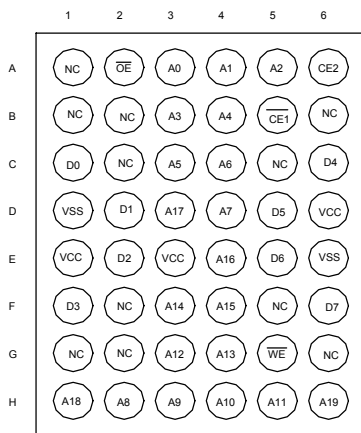
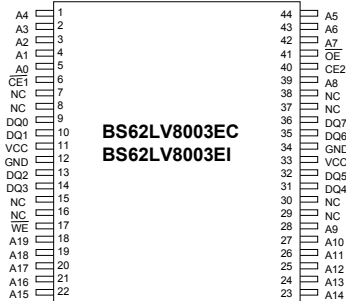

48-Ball CSP top View

### FUNCTIONAL BLOCK DIAGRAM

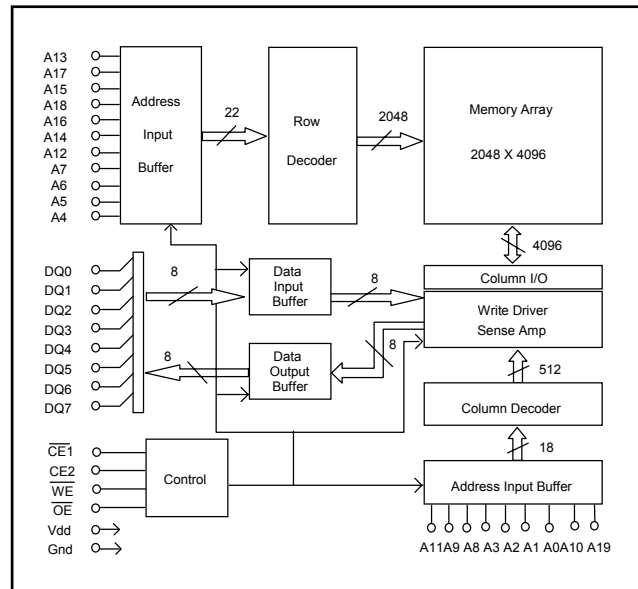

Brilliance Semiconductor Inc. reserves the right to modify document contents without notice.

**■ PIN DESCRIPTIONS**

Name	Function
<b>A0-A19 Address Input</b>	These 20 address inputs select one of the 1,048,576 x 8-bit words in the RAM
<b>CE1 Chip Enable 1 Input</b> <b>CE2 Chip Enable 2 Input</b>	CE1 is active LOW and CE2 is active HIGH. Both chip enables must be active when data read from or write to the device. If either chip enable is not active, the device is deselected and is in a standby power mode. The DQ pins will be in the high impedance state when the device is deselected.
<b>WE Write Enable Input</b>	The write enable input is active LOW and controls read and write operations. With the chip selected, when WE is HIGH and OE is LOW, output data will be present on the DQ pins; when WE is LOW, the data present on the DQ pins will be written into the selected memory location.
<b>OE Output Enable Input</b>	The output enable input is active LOW. If the output enable is active while the chip is selected and the write enable is inactive, data will be present on the DQ pins and they will be enabled. The DQ pins will be in the high impedance state when OE is inactive.
<b>DQ0-DQ7 Data Input/Output Ports</b>	These 8 bi-directional ports are used to read data from or write data into the RAM.
<b>Vcc</b>	Power Supply
<b>Gnd</b>	Ground

**■ TRUTH TABLE**

MODE	WE	CE1	CE2	OE	I/O OPERATION	Vcc CURRENT
Not selected (Power Down)	X	H	X	X	High Z	I <sub>CCSB</sub> , I <sub>CCSB1</sub>
	X	X	L	X		
Output Disabled	H	L	H	H	High Z	I <sub>CC</sub>
Read	H	L	H	L	DOUT	I <sub>CC</sub>
Write	L	L	H	X	DIN	I <sub>CC</sub>

**■ ABSOLUTE MAXIMUM RATINGS<sup>(1)</sup>**

SYMBOL	PARAMETER	RATING	UNITS
V <sub>TERM</sub>	Terminal Voltage with Respect to GND	-0.5 to V <sub>CC</sub> +0.5	V
T <sub>BIAS</sub>	Temperature Under Bias	-40 to +125	°C
T <sub>STG</sub>	Storage Temperature	-60 to +150	°C
P <sub>T</sub>	Power Dissipation	1.0	W
I <sub>OUT</sub>	DC Output Current	20	mA

1. Stresses greater than those listed under ABSOLUTE MAXIMUM RATINGS may cause permanent damage to the device. This is a stress rating only and functional operation of the device at these or any other conditions above those indicated in the operational sections of this specification is not implied. Exposure to absolute maximum rating conditions for extended periods may affect reliability.

**■ OPERATING RANGE**

RANGE	AMBIENT TEMPERATURE	Vcc
Commercial	0 °C to +70 °C	2.4V ~ 3.6V
Industrial	-40 °C to +85 °C	2.4V ~ 3.6V

**■ CAPACITANCE <sup>(1)</sup> (TA = 25°C, f = 1.0 MHz)**

SYMBOL	PARAMETER	CONDITIONS	MAX.	UNIT
C <sub>IN</sub>	Input Capacitance	V <sub>IN</sub> =0V	10	pF
C <sub>DQ</sub>	Input/Output Capacitance	V <sub>I/O</sub> =0V	12	pF

1. This parameter is guaranteed and not tested.

**DC ELECTRICAL CHARACTERISTICS ( TA = 0°C to + 70°C )**

PARAMETER NAME	PARAMETER	TEST CONDITIONS	MIN.	TYP. <sup>(1)</sup>	MAX.	UNITS
V <sub>IL</sub>	Guaranteed Input Low Voltage <sup>(2)</sup>	V <sub>CC</sub> =3V	-0.5	--	0.8	V
V <sub>IH</sub>	Guaranteed Input High Voltage <sup>(2)</sup>	V <sub>CC</sub> =3V	2.0	--	V <sub>CC</sub> +0.2	V
I <sub>IL</sub>	Input Leakage Current	V <sub>CC</sub> = Max, V <sub>IN</sub> = 0V to V <sub>CC</sub>	--	--	1	uA
I <sub>OL</sub>	Output Leakage Current	V <sub>CC</sub> = Max, $\overline{CE1} = V_{IH}$ or CE2 = V <sub>IL</sub> or $\overline{OE} = V_{IH}$ , V <sub>IO</sub> = 0V to V <sub>CC</sub>	--	--	1	uA
V <sub>OL</sub>	Output Low Voltage	V <sub>CC</sub> = Max, I <sub>OL</sub> = 2mA	--	--	0.4	V
V <sub>OH</sub>	Output High Voltage	V <sub>CC</sub> = Min, I <sub>OH</sub> = -1mA	2.4	--	--	V
I <sub>CC</sub>	Operating Power Supply Current	$\overline{CE1} = V_{IL}$ , CE2 = V <sub>IH</sub> , I <sub>DQ</sub> = 0mA, F = F <sub>max</sub> <sup>(3)</sup>	--	--	20	mA
I <sub>CCSB</sub>	Standby Current-TTL	$\overline{CE1} = V_{IH}$ , CE2 = V <sub>IL</sub> , I <sub>DQ</sub> = 0mA	--	--	1	mA
I <sub>CCSB1</sub>	Standby Current-CMOS	$\overline{CE1} \geq V_{CC} - 0.2V$ , CE2 $\leq 0.2V$ V <sub>IN</sub> $\geq V_{CC} - 0.2V$ or V <sub>IN</sub> $\leq 0.2V$	--	0.5	3	uA

1. Typical characteristics are at TA = 25°C.

2. These are absolute values with respect to device ground and all overshoots due to system or tester noise are included.

3. F<sub>max</sub> = 1/t<sub>RC</sub>.

**DATA RETENTION CHARACTERISTICS ( TA = 0 to + 70°C )**

SYMBOL	PARAMETER	TEST CONDITIONS	MIN.	TYP. <sup>(1)</sup>	MAX.	UNITS
V <sub>DR</sub>	V <sub>CC</sub> for Data Retention	$\overline{CE1} \geq V_{CC} - 0.2V$ or CE2 $\leq 0.2V$ or V <sub>IN</sub> $\geq V_{CC} - 0.2V$ or V <sub>IN</sub> $\leq 0.2V$	1.5	--	--	V
I <sub>CCDR</sub>	Data Retention Current	$\overline{CE1} \geq V_{CC} - 0.2V$ or CE2 $\leq 0.2V$ V <sub>IN</sub> $\geq V_{CC} - 0.2V$ or V <sub>IN</sub> $\leq 0.2V$	--	0.4	2	uA
t <sub>CDR</sub>	Chip Deselect to Data Retention Time	See Retention Waveform	0	--	--	ns
t <sub>R</sub>	Operation Recovery Time		T <sub>RC</sub> <sup>(2)</sup>	--	--	ns

1. V<sub>CC</sub> = 1.5V, T<sub>A</sub> = + 25°C



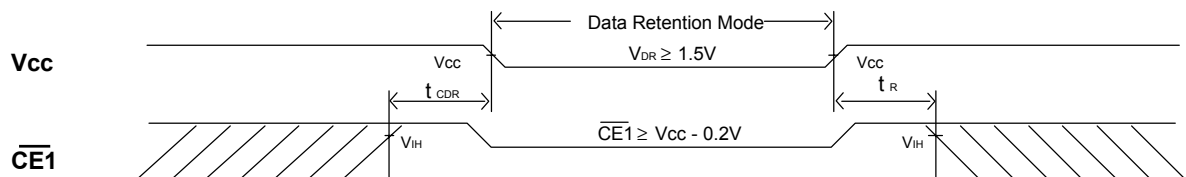
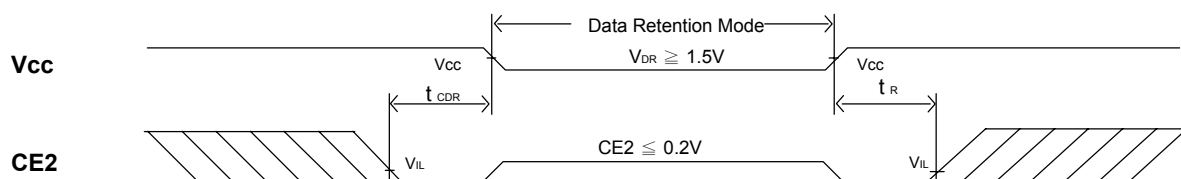

2. t<sub>RC</sub> = Read Cycle Time

**LOW V<sub>CC</sub> DATA RETENTION WAVEFORM (1) (  $\overline{CE1}$  Controlled )**

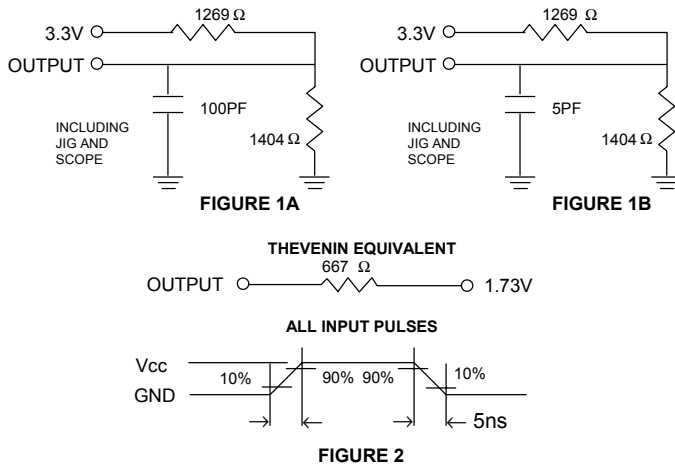
**LOW V<sub>CC</sub> DATA RETENTION WAVEFORM (2) ( CE2 Controlled )**

**AC TEST CONDITIONS**

Input Pulse Levels	$V_{cc}/0$
Input Rise and Fall Times	5ns
Input and Output Timing Reference Level	$0.5V_{cc}$

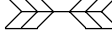
**AC TEST LOADS AND WAVEFORMS**

**KEY TO SWITCHING WAVEFORMS**

WAVEFORM	INPUTS	OUTPUTS
	MUST BE STEADY	MUST BE STEADY
	MAY CHANGE FROM H TO L	WILL BE CHANGE FROM H TO L
	MAY CHANGE FROM L TO H	WILL BE CHANGE FROM L TO H
	DON'T CARE: ANY CHANGE PERMITTED	CHANGE: STATE UNKNOWN
	DOES NOT APPLY	CENTER LINE IS HIGH IMPEDANCE "OFF" STATE

**AC ELECTRICAL CHARACTERISTICS (  $T_A = 0^\circ\text{C}$  to  $+70^\circ\text{C}$ ,  $V_{cc} = 3\text{V}$  )**
**READ CYCLE**

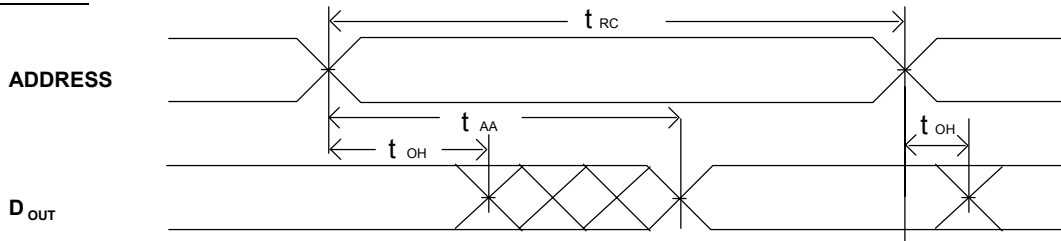
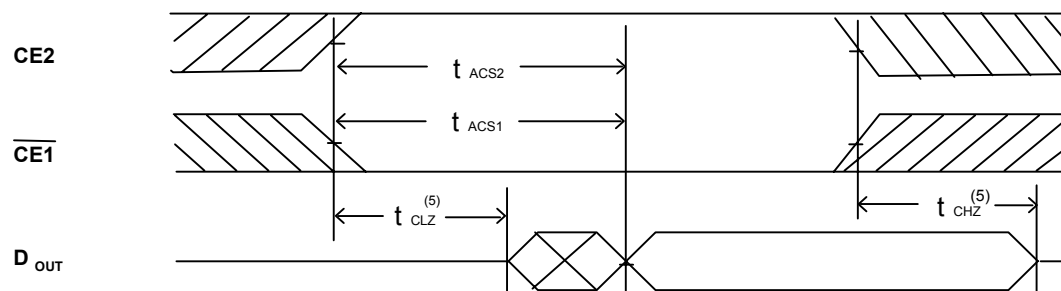
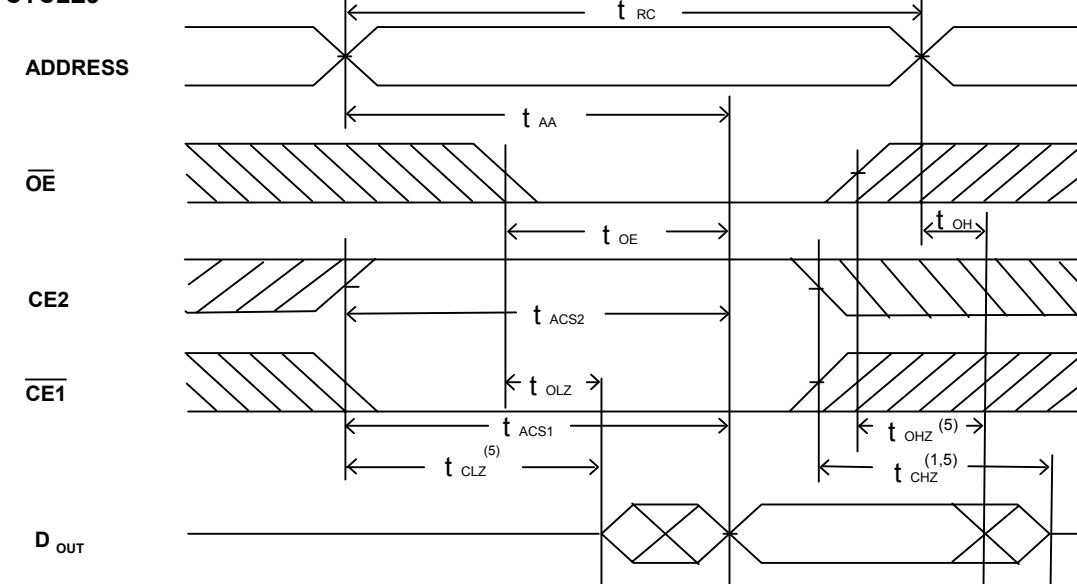
JEDEC PARAMETER NAME	PARAMETER NAME	DESCRIPTION	BS62LV8003-70			BS62LV8003-10			UNIT
			MIN.	TYP.	MAX.	MIN.	TYP.	MAX.	
$t_{AVAX}$	$t_{RC}$	Read Cycle Time	70	--	--	100	--	--	ns
$t_{AVQV}$	$t_{AA}$	Address Access Time	--	--	70	--	--	100	ns
$t_{E1LQV}$	$t_{ACS1}$	Chip Select Access Time ( $\overline{CE}1$ )	--	--	70	--	--	100	ns
$t_{E2LQV}$	$t_{ACS2}$	Chip Select Access Time ( $CE2$ )	--	--	70	--	--	100	ns
$t_{GLQV}$	$t_{OE}$	Output Enable to Output Valid	--	--	35	--	--	50	ns
$t_{ELQX}$	$t_{CLZ}$	Chip Select to Output Low Z	10	--	--	15	--	--	ns
$t_{GLQX}$	$t_{OLZ}$	Output Enable to Output in Low Z	10	--	--	15	--	--	ns
$t_{EHQZ}$	$t_{CHZ}$	Chip Deselect to Output in High Z	0	--	35	0	--	40	ns
$t_{GHQZ}$	$t_{OHZ}$	Output Disable to Output in High Z	0	--	30	0	--	35	ns
$t_{AXOX}$	$t_{OH}$	Output Disable to Output Address Change	10	--	--	15	--	--	ns

**SWITCHING WAVEFORMS (READ CYCLE)**
**READ CYCLE1 (1,2,4)**

**READ CYCLE2 (1,3,4)**

**READ CYCLE3 (1,4)**

**NOTES:**

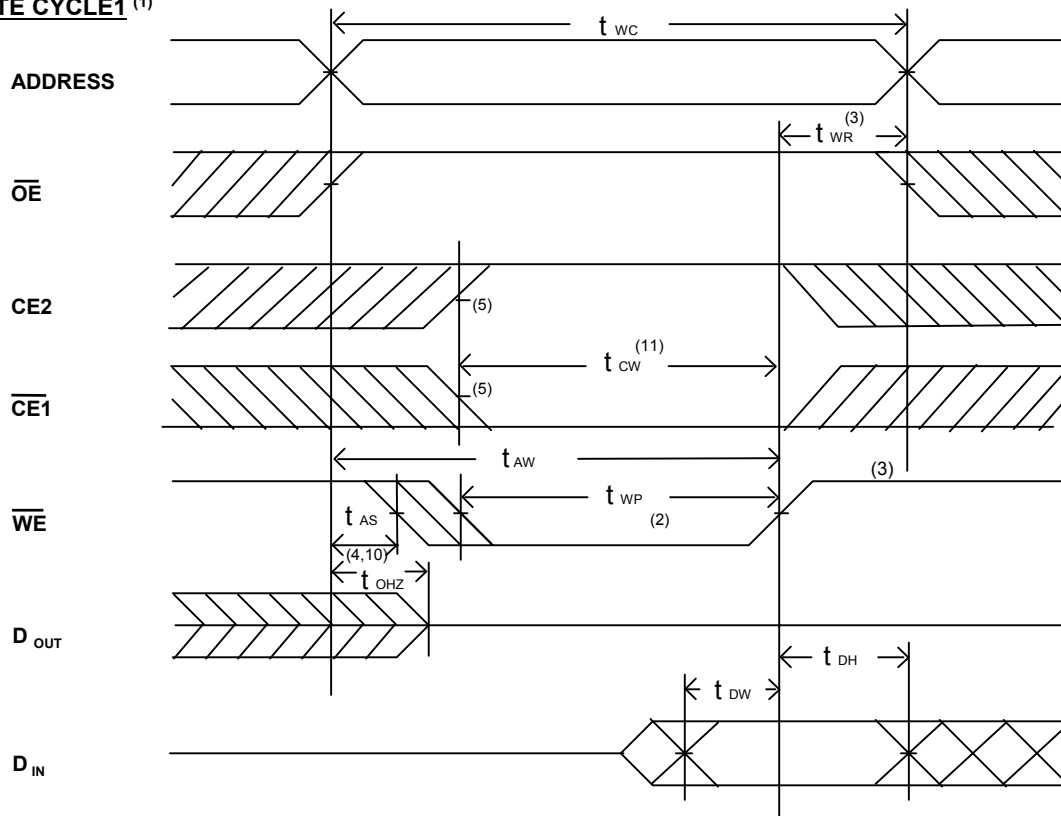
1. WE is high in read Cycle.
2. Device is continuously selected when  $\overline{CE1} = V_{IL}$  and  $CE2 = V_{IH}$ .
3. Address valid prior to or coincident with CE1 transition low and CE2 transition high.
4.  $\overline{OE} = V_{IL}$ .
5. Transition is measured  $\pm 500mV$  from steady state with  $C_L = 5pF$  as shown in Figure 1B. The parameter is guaranteed but not 100% tested.

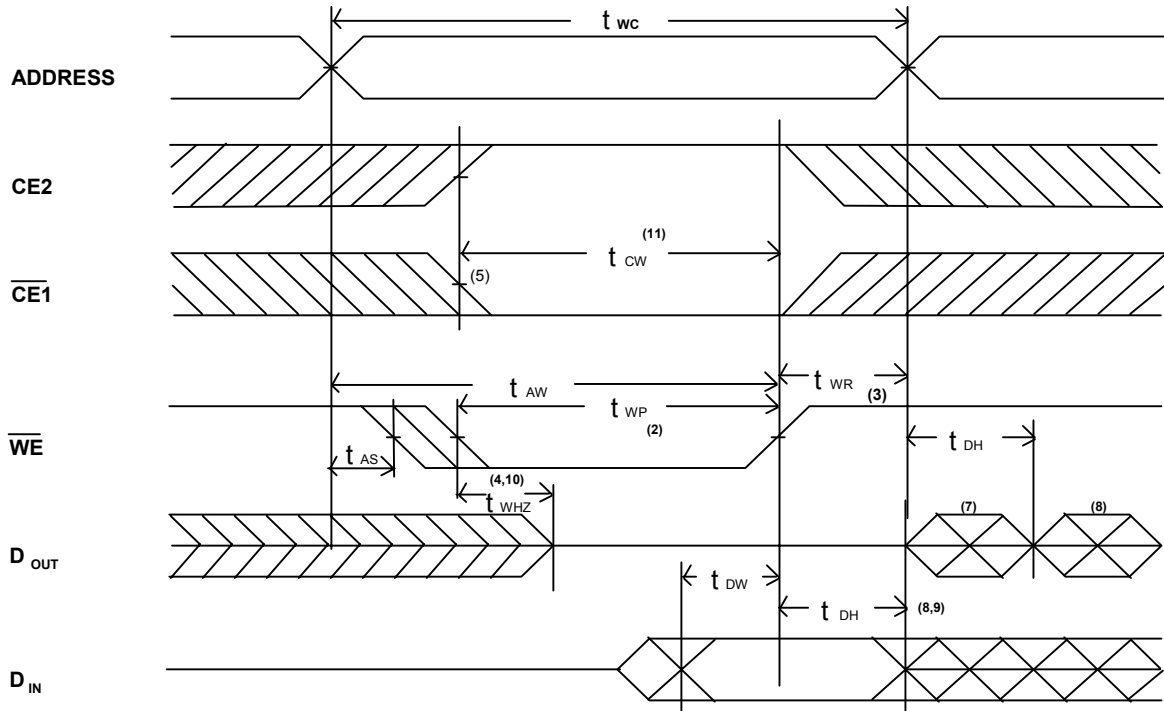
**■ AC ELECTRICAL CHARACTERISTICS ( TA = 0°C to + 70°C , Vcc = 3.0V )**
**WRITE CYCLE**

JEDEC PARAMETER NAME	PARAMETER NAME	DESCRIPTION	BS62LV8003-70			BS62LV8003-10			UNIT
			MIN.	TYP.	MAX.	MIN.	TYP.	MAX.	
$t_{AVAX}$	$t_{WC}$	Write Cycle Time	70	--	--	100	--	--	ns
$t_{E1LWH}$	$t_{CW}$	Chip Select to End of Write	70	--	--	100	--	--	ns
$t_{AVVL}$	$t_{AS}$	Address Set up Time	0	--	--	0	--	--	ns
$t_{AVWH}$	$t_{AW}$	Address Valid to End of Write	70	--	--	100	--	--	ns
$t_{WLWH}$	$t_{WP}$	Write Pulse Width	35	--	--	50	--	--	ns
$t_{WHAX}$	$t_{WR}$	Write Recovery Time (CE2, CE1, WE)	0	--	--	0	--	--	ns
$t_{WLOZ}$	$t_{WHZ}$	Write to Output in High Z	0	--	30	0	--	40	ns
$t_{DVWH}$	$t_{DW}$	Data to Write Time Overlap	30	--	--	40	--	--	ns
$t_{WHDX}$	$t_{DH}$	Data Hold from Write Time	0	--	--	0	--	--	ns
$t_{GHOZ}$	$t_{OHZ}$	Output Disable to Output in High Z	0	--	30	0	--	40	ns
$t_{WHQX}$	$t_{OW}$	End of Write to Output Active	5	--	--	10	--	--	ns

**■ SWITCHING WAVEFORMS (WRITE CYCLE)**
**WRITE CYCLE1<sup>(1)</sup>**

**WRITE CYCLE2 (1,6)**

**NOTES:**

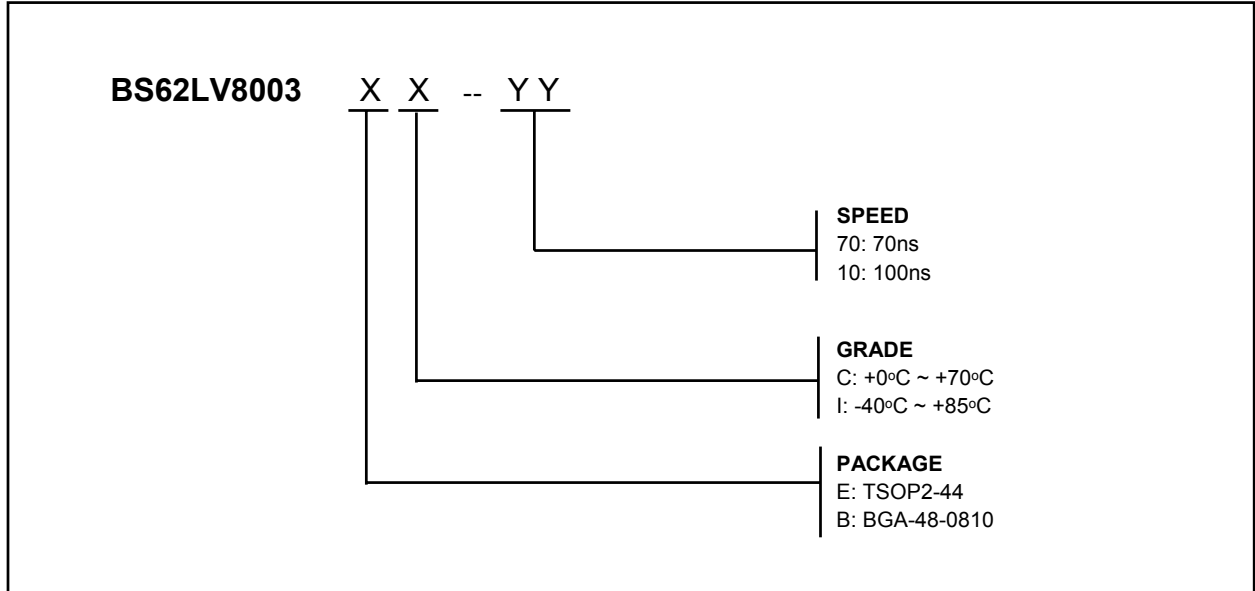
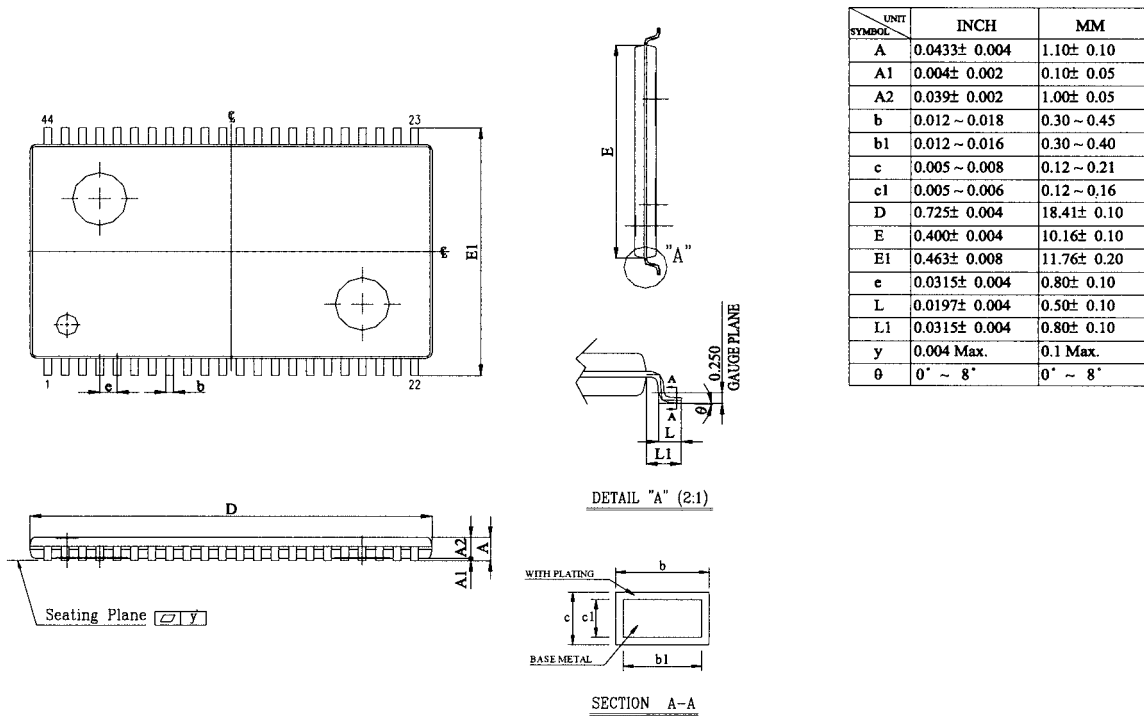
1. WE must be high during address transitions.
2. The internal write time of the memory is defined by the overlap of CE2,  $\overline{CE1}$  and  $\overline{WE}$  low. All signals must be active to initiate a write and any one signal can terminate a write by going inactive. The data input setup and hold timing should be referenced to the second transition edge of the signal that terminates the write.
3.  $t_{wr}$  is measured from the earlier of CE2 going low, or  $\overline{CE1}$  or  $\overline{WE}$  going high at the end of write cycle.
4. During this period, DQ pins are in the output state so that the input signals of opposite phase to the outputs must not be applied.
5. If the  $\overline{CE2}$  high transition or CE1 low transition occurs simultaneously with the  $\overline{WE}$  low transitions or after the  $\overline{WE}$  transition, output remain in a high impedance state.
6.  $\overline{OE}$  is continuously low ( $\overline{OE} = V_{IL}$ ).
7. D<sub>OUT</sub> is the same phase of write data of this write cycle.
8. D<sub>OUT</sub> is the read data of next address.
9. If CE2 is high or  $\overline{CE1}$  is low during this period, DQ pins are in the output state. Then the data input signals of opposite phase to the outputs must not be applied to them.
10. Transition is measured  $\pm 500mV$  from steady state with  $C_L = 5pF$  as shown in Figure 1B. The parameter is guaranteed but not 100% tested.
11.  $t_{cw}$  is measured from the later of CE2 going high or  $\overline{CE1}$  going low to the end of write.

**ORDERING INFORMATION**

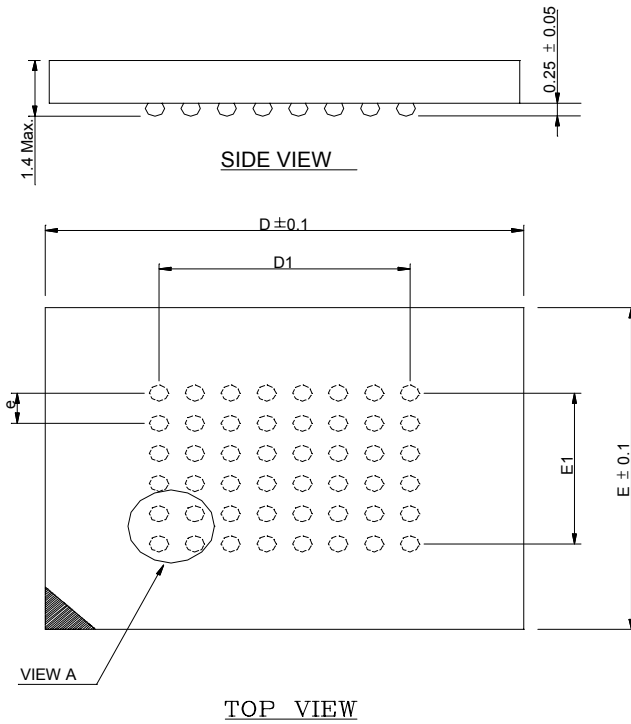
**PACKAGE DIMENSIONS**

**TSOP2-44**



**■ PACKAGE DIMENSIONS (continued)**

**48 mini-BGA (8 x 10mm)**

**NOTES:**

- 1: CONTROLLING DIMENSIONS ARE IN MILLIMETERS.
- 2: PIN#1 DOT MARKING BY LASER OR PAD PRINT.
- 3: SYMBOL "N" IS THE NUMBER OF SOLDER BALLS.

N	D	E	D1	E1	e
48	10.0	8.0	5.25	3.75	0.75

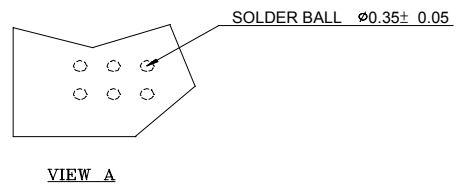

***REVISION HISTORY***

<b>Revision</b>	<b>Description</b>	<b>Date</b>	<b>Note</b>
<b>2.2</b>	<b>2001 Data Sheet release</b>	<b>Apr. 15, 2001</b>	
<b>2.3</b>	<b>Modify Standby Current (Typ. and Max.)</b>	<b>Jun. 29, 2001</b>	
<b>2.4</b>	<b>Modify some AC parameters</b>	<b>April,11,2002</b>	