

128-Bit Read-Only IDIC[®] for RF Identification

Description

The e5530 is part of a closed coupled identification system. It receives power from an RF transmitter which is coupled inductively to the IDIC[®]. The frequency is typically 100 to 450 kHz. Receiving RF, the IDIC[®] responds with a data stream by damping the incoming RF

via an internal load. This damping-in-turn can be detected by the interrogator. The identifying data are stored in a 128 bit PROM on the e5530, realized as an array of laser-programmable fuses. The logic block diagram for the e5530 is shown in figure 2. The data are output bit-serially as a code of length 128, 96, 64 or 32 bits. The chips are factory-programmed with a unique code.

Features

- Low power, low voltage CMOS
- Rectifier, voltage limiter, clock extraction on-chip (no battery)
- Small size
- Factory laser programmable ROM
- Operating temperature range -40 to +125°C
- Radio Frequency (RF): 100 to 450 kHz
- Transmission options
Code length: 128, 96, 64, 32 bits

Bitrate [bit/s]: RF/8, RF/16, RF/32, RF/40, RF/50, RF/64, RF/80, RF/100, RF/128,
Modulation: FSK, PSK, BIPH, Manchester, BIPH-FSK

- FDX-B compatible coding possible

Application

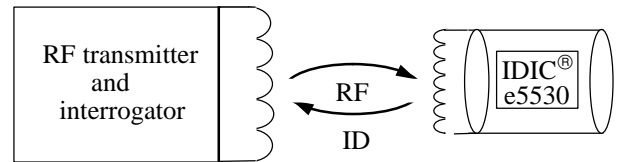

Figure 1. Application

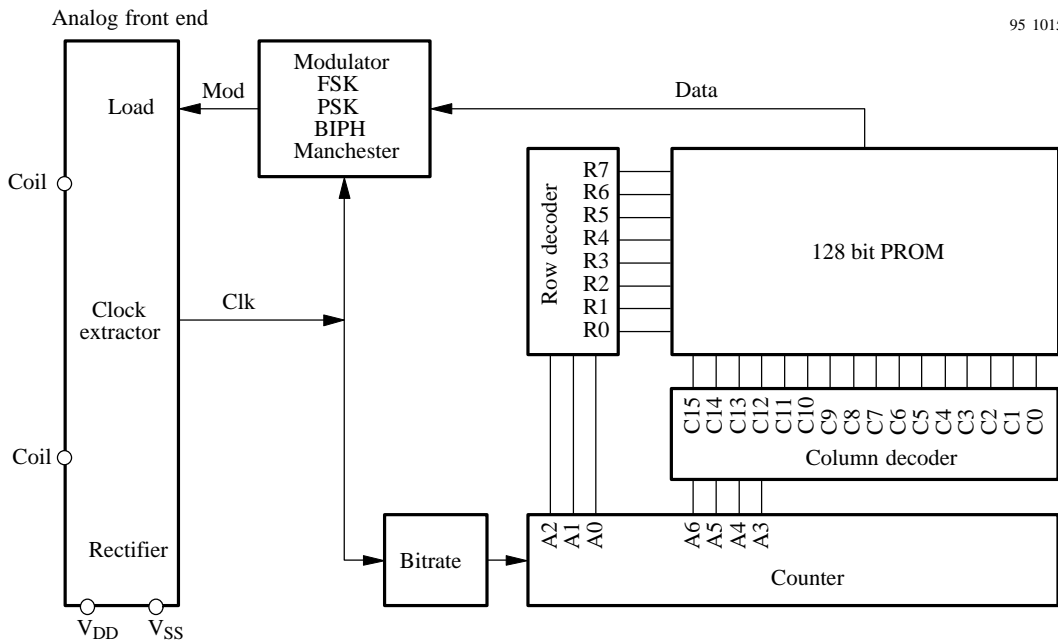

Figure 2. Block diagram

IDIC[®] stands for **ID**entification **I**ntegrated **C**ircuit and is a trademark of TEMIC Semiconductors.

Ordering Information

Extended Type Number	Package	Modul.	Data Rate	Configuration	Checksum	Header	ID Code	SPQ (Minimum Volume)	Minimum Order Volume
e5530H-232-DOW e5530H-232-DIT e5530H-232-S8	DOW DIT SO8	Manch.	RF/32	64 bit	no checksum	E6	fixed and unique code	10 kpcs 10 kpcs 1120	10 kpcs 10 kpcs 1120
e5530H-zzz-DOW * e5530H-zzz-DIT * e5530H-zzz-S8 *	DOW DIT SO8	defined by customer							> 600 kpcs p.a. > 600 kpcs p.a. > 400 kpcs p.a.

- * 1) Definition of customized part number basing on orders for first year volume (300 kpcs)
 2) Definition of header, ID code, checksum etc. according to customers data base
 3) 5.000 US\$ initial cost for customer specific laser-fusing
 4) Lead time 3 month
 5) Low volume customized applications may be covered by TK5551-PP programming.
 With identical features of TK5530H-zzz-PP possible

Order Code

The full order code for the e5530 is **e5530H-zzz-pkg** or **e5530G-zzz-pkg**, where *zzz* is a customer specific number defined by TEMIC Semiconductors. **pkg** (package) defines the delivery form:

- DOW factory programmed, tested unsawn, backlapped (15 mils) wafers
- DIT cutted chips in wafflepack (**D**ice **I**n **T**ray)
- S8 SO8-packaged parts

Chip Dimensions

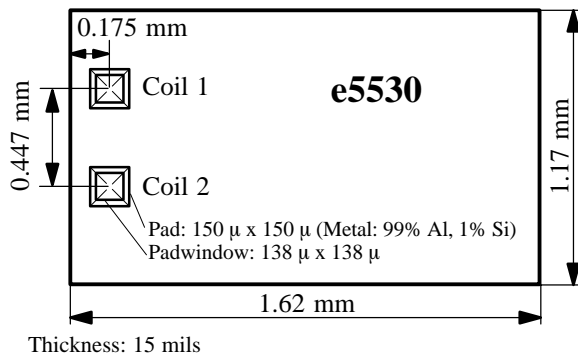
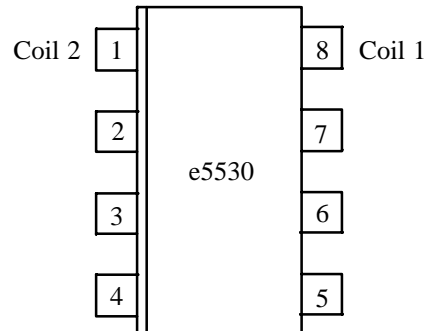

Figure 3. Chip size



Note: Pins 2 to 7 have to be open. They are not specified for applications

Figure 4. Pinning SO8

Pads

Name	Pad Window	Function
Coil1	138 × 138 μm ²	1st coil pad
Coil2	138 × 138 μm ²	2nd coil pad

Functional Description

Read Operation

After power up, once the e5530 has detected the incoming RF field, the IC continuously transmits the identification code as long as the RF signal is applied. The transition from the last bit to bit 1 of the next sequence occurs without interruption. Data is transmitted by damping the incoming RF signal by an internal load. This load changes are detected by the reader station.

Different kinds of modulation and bitrates are optionally available.

Rectifier

For internal power supply, an on-chip bridge rectifier is used which consists of two diodes and two n-channel transistors. A Zener diode, which protects the circuit against overvoltage on the coil inputs, and a smoothing capacitor for the internal supply are also provided.

Damping Load

Incoming RF will be damped by the power consumption of the IC itself and by an internal load, which is controlled by the modulator. The loads are p-channel transistors connected between V_{DD} and the coil inputs.

The IDIC includes mask options for the load circuit: single-side, double-side and alternate-side modulation.

There are four modulation methods available which can be selected by fuses. The corresponding timing diagram is shown in figure 5.

FSK Modulation

Logical data “1” and “0” are represented as two different frequencies of damping. The frequency for “1” is $RF/10$, a “0” divides RF by 8.

PSK Modulation

The external coil is damped with a carrier frequency of $RF/2$. A logical “1” causes (at the end of the bit period) a 180° phase shift on the carrier frequency, while a logical “0” causes no phase shift.

Biphase Modulation

Logical “1” produces a signal which is the same as the internal bitclock. A logical “0” produces no signal change in the middle of the bit period.

Manchester Modulation

A logical “1” causes a rising edge in the middle of a bit period (i.e., switch damping off), while a logical “0” causes a falling edge (i.e., switch damping on).

A combination of Biphase- and FSK-modulation is also optionally available. The available combinations between the modulation types and the bitrates are shown in table “Transmission Options”.

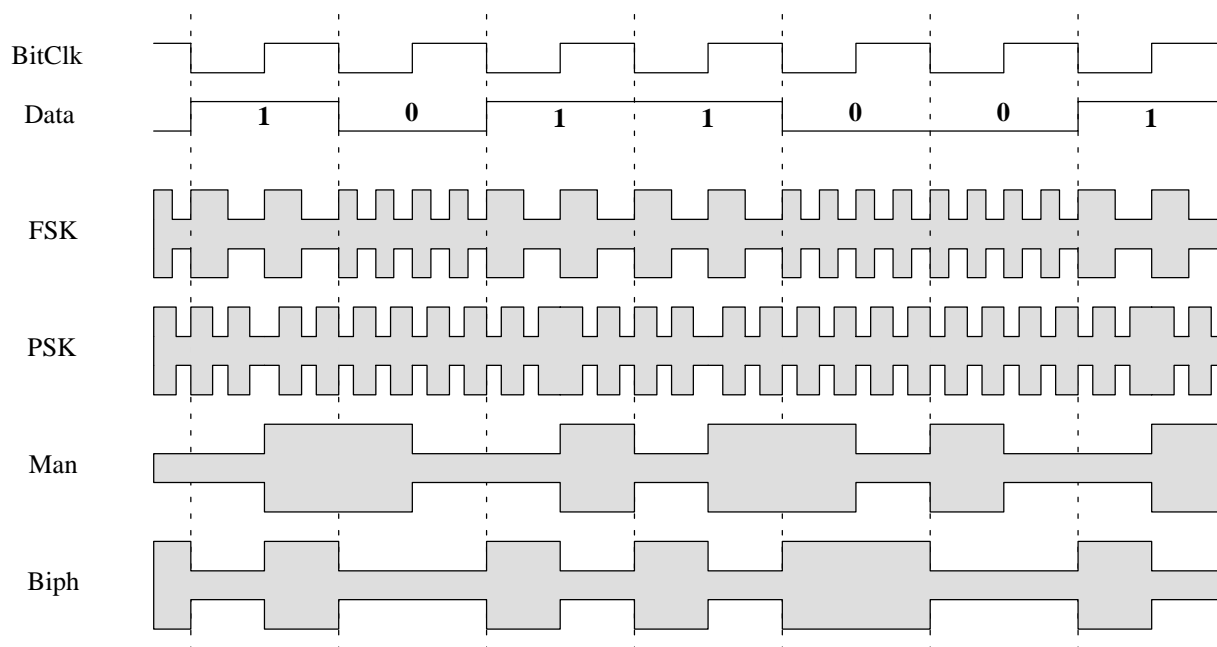

Figure 5. Timing diagram for modulation options

Table 5. Transmission options

Modulation	Carrier Frequency (CF)	Bitrate [bit/s]
FSK	RF/8, RF/10	RF/32, RF/40, RF/50, RF/64, RF/80, RF/100, RF/128
PSK	RF/2	CF/4, 8, 16, 32
Biphase		RF/8, RF/16, RF/32, RF/64, RF/100, RF/128
Manchester		RF/8, RF/16, RF/32, RF/64, RF/100, RF/128

Reading Distances

The e5530 is able to operate from very weak fields. Nevertheless, there are some general rules which influence the achievable reading distance.

- Best results are accomplished when the transponder points towards the reader coil.
- The transponder should not be embedded in metal, which will reduce the applicable magnetic field and thus the reading distance.
- The strength of the generated magnetic field and the sensitivity of the demodulator are the most important factors for a good reading distance.

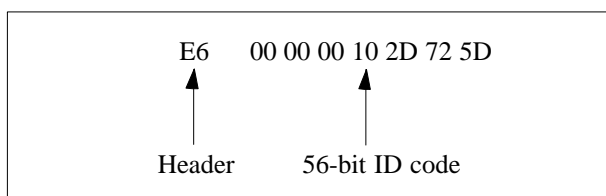

Figure 6. Example for a 64-bit code

The identification code is transmitted continuously. After the RF field is applied, the e5530H-232 starts with the first bit (MSB) of the header byte 'E6hex' ('1110 0110'), followed by a unique 56-bit serial number. No checksum is included in this sample code.

Pulsing the RF field may reduce the synchronization task as the first byte transmitted is known already (i.e., E6hex). This is even feasible, if the first bit may be lost due to reader synchronization problems.

Customer ID Code Selection

In general the customer may choose any ID code suitable to his application. To avoid code duplication, TEMIC Semiconductors will define a fixed header – i.e, the first 8 bits of the code – for each customer.

Modes of Operation – Options

For any new product variant, the customer has to select the following operation options which are configured in the laser ROM as well:

- Bitrate, which is defined as field clocks per bit (e.g., RF/40 = 125 kHz/40 = 3.125 kBit/s) (see table “Transmission Options”)
- Modulation method (see figure 5)
- Code length: 32, 64, 96 or 128 bits

For programming the ID code into the laser ROM, one of the following data has to be supplied:

- ID code algorithm which is implemented in TEMIC Semiconductors code management software (TEMIC Semiconductors will generate the codes as requested)
- Customer generated ID codes on floppy disk or per email/ftp.

The format has to comply to the following rules:

- The ID code file is a plain ASCII text file.
- The code files should be compressed. Please make self extracting files.
- The code files are used in alphabetical order of their file names (including letters and numbers). Used – i.e. programmed – code files are discarded.
- Each line of the code file must contain one ID code for one IC.
- The code is in hexadecimal format. The code may contain spaces for better readability.
- The code line is exactly as long as the selected code length (e.g. 64 bits 16 hex numbers).
- The line must end with a carriage return.
- The first 8 bits are fixed, this is the unique customer header which is defined by TEMIC Semiconductors.
- Each hexadecimal code entry must be preceded by a decimal serial number. Serial number and code must be separated by a space.
- The serial number has to be unique and is up-counting to avoid double programming.
- The series numbers of two consecutive files (file name!) has to count up too for proper linking.

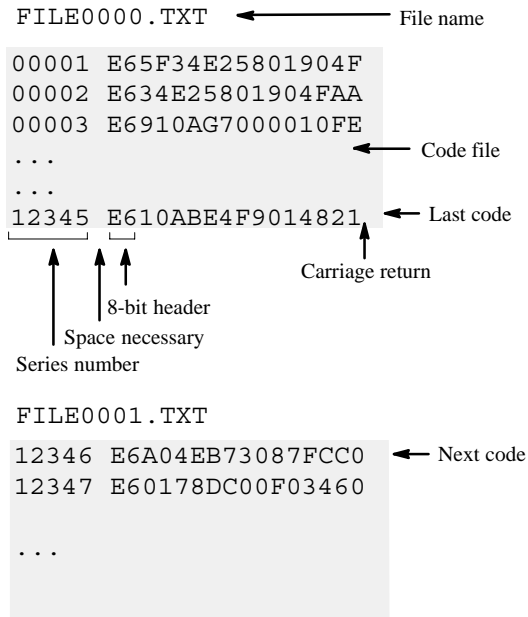

Samples

TEMIC Semiconductors supplies e5530 samples, which are set to Manchester modulation at RF/32 with a 64-bit ID code (order code: e5530H-232 S8).

Figure 7. Example of two code files with header = E6 and 64-bit code length

Absolute Maximum Ratings

Parameters	Symbol	Value	Unit
Maximum current into Coil1 and Coil2	I _{coil}	10	mA
Maximum power dissipation (dice)	P _{tot}	100	mW*
Maximum ambient air temperature with voltage applied	T _{amb}	-40 to +125	°C
Storage temperature	T _{stg}	-65 to +200	°C

* Free-air condition. Time of application: 1 s

Stresses above those listed under ‘Absolute Maximum Ratings’ may cause permanent damage to the device. Functional operation of the device at these conditions is not implied.

Operating Characteristics

T_{amb} = 25°C, reference terminal is V_{DD}, operating voltage V_{DD} – V_{SS} = 3 V DC, unless otherwise specified

Parameters	Test Conditions / Pins	Symbol	Min.	Typ. *	Max.	Unit
Operating voltage	Condition for logic test	V _{SS}	-1.5		-5.0	V
Operating temperature		T _{amb}	-40		125	°C
Input frequency (RF)		f _{CLK}	100		450	kHz
Operating current	f _{CLK} = 125 kHz, V _{SS} = -2 V	I _{CC}		3		µA
Clamp voltage	I = 4 mA	V _{CL}	6.7		10	V

* Typical parameters represent the statistical mean values

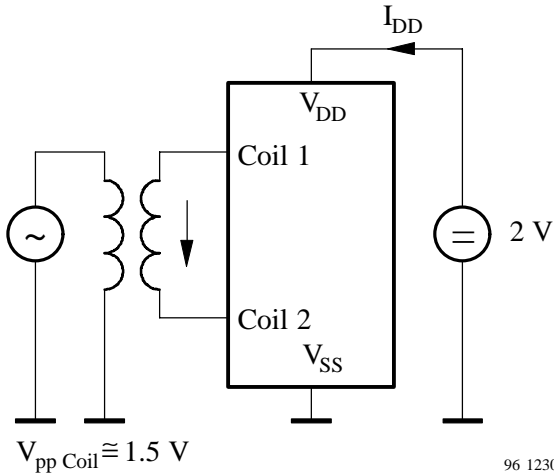

Figure 8. Measurement setup for I_{DD}

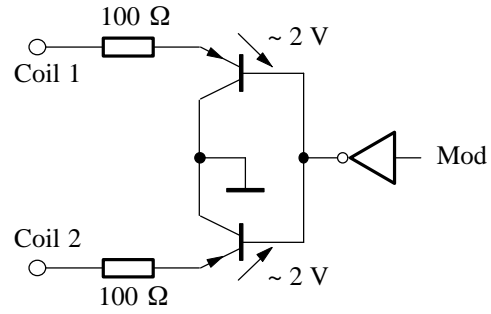

Figure 9. Simplified damping circuit

Application Example

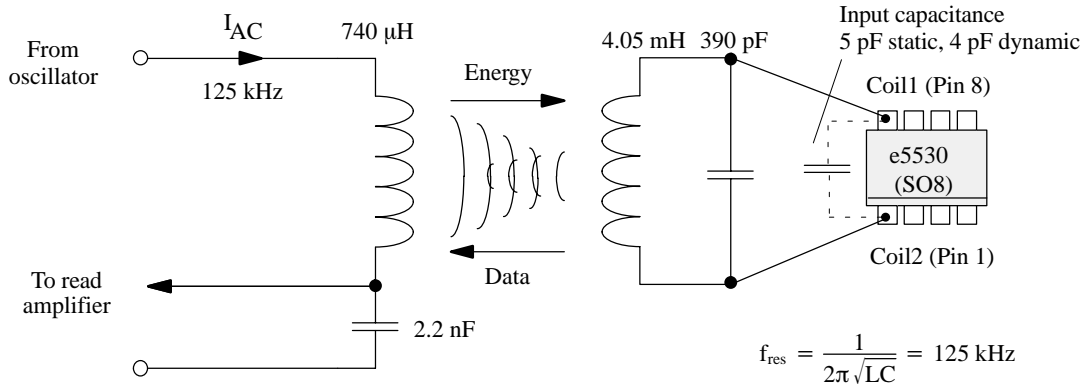
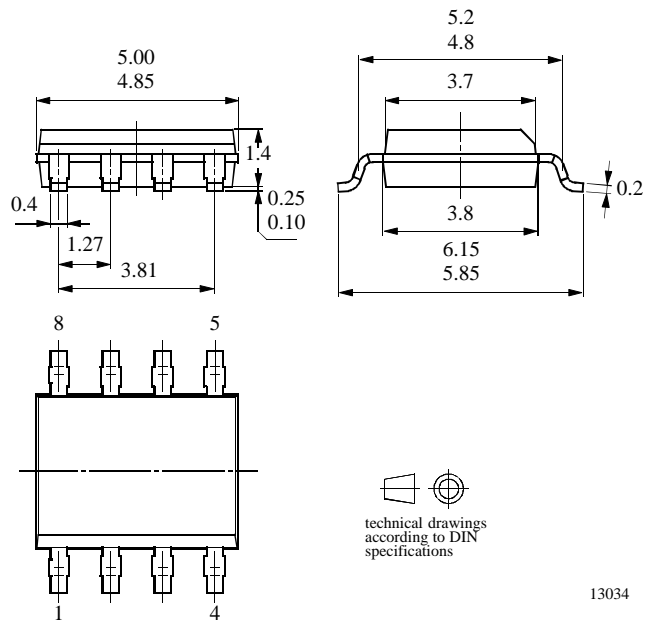

Figure 10. Typical application circuit

Package Information

Package SO8

Dimensions in mm



Ozone Depleting Substances Policy Statement

It is the policy of **TEMIC Semiconductor GmbH** to

1. Meet all present and future national and international statutory requirements.
2. Regularly and continuously improve the performance of our products, processes, distribution and operating systems with respect to their impact on the health and safety of our employees and the public, as well as their impact on the environment.

It is particular concern to control or eliminate releases of those substances into the atmosphere which are known as ozone depleting substances (ODSs).

The Montreal Protocol (1987) and its London Amendments (1990) intend to severely restrict the use of ODSs and forbid their use within the next ten years. Various national and international initiatives are pressing for an earlier ban on these substances.

TEMIC Semiconductor GmbH has been able to use its policy of continuous improvements to eliminate the use of ODSs listed in the following documents.

1. Annex A, B and list of transitional substances of the Montreal Protocol and the London Amendments respectively
2. Class I and II ozone depleting substances in the Clean Air Act Amendments of 1990 by the Environmental Protection Agency (EPA) in the USA
3. Council Decision 88/540/EEC and 91/690/EEC Annex A, B and C (transitional substances) respectively.

TEMIC Semiconductor GmbH can certify that our semiconductors are not manufactured with ozone depleting substances and do not contain such substances.

We reserve the right to make changes to improve technical design and may do so without further notice.

Parameters can vary in different applications. All operating parameters must be validated for each customer application by the customer. Should the buyer use TEMIC Semiconductors products for any unintended or unauthorized application, the buyer shall indemnify TEMIC Semiconductors against all claims, costs, damages, and expenses, arising out of, directly or indirectly, any claim of personal damage, injury or death associated with such unintended or unauthorized use.

Data sheets can also be retrieved from the Internet: <http://www.temic-semi.com>

TEMIC Semiconductor GmbH, P.O.B. 3535, D-74025 Heilbronn, Germany
Telephone: 49 (0)7131 67 2594, Fax number: 49 (0)7131 67 2423