

FEATURES

- 200MHz ARM920T Processor
 - 16kbyte Instruction Cache
 - 16kbyte Data Cache
 - Windows CE enabled MMU
- MaverickCrunch™ Math Engine
 - Floating point, integer and signal processing instructions
 - Optimized for digital music compression and decompression algorithms
 - Hardware interlocks allow in-line coding
- MaverickLock™ Security Features
 - Incorporates boot ROM, laser fuses, and gate-level IP
 - Multiple security vendors can co-exist in same system
 - Exceeds SDMI requirements

**Internet Audio Jukebox Processor
with MaverickCrunch™ Audio
Compression and MaverickLock™
Security**

OVERVIEW

The EP9312 is an ARM920T based system on chip designed for use in audio jukebox applications where processor performance, signal processing capability, communications bandwidth, storage capabilities, and the user interface are properly balanced to provide up to 4 streams of compressed audio data (MP3, WMA, and other audio compression standards) through a home network.

(Cont.)

(Cont.)

BLOCK DIAGRAM

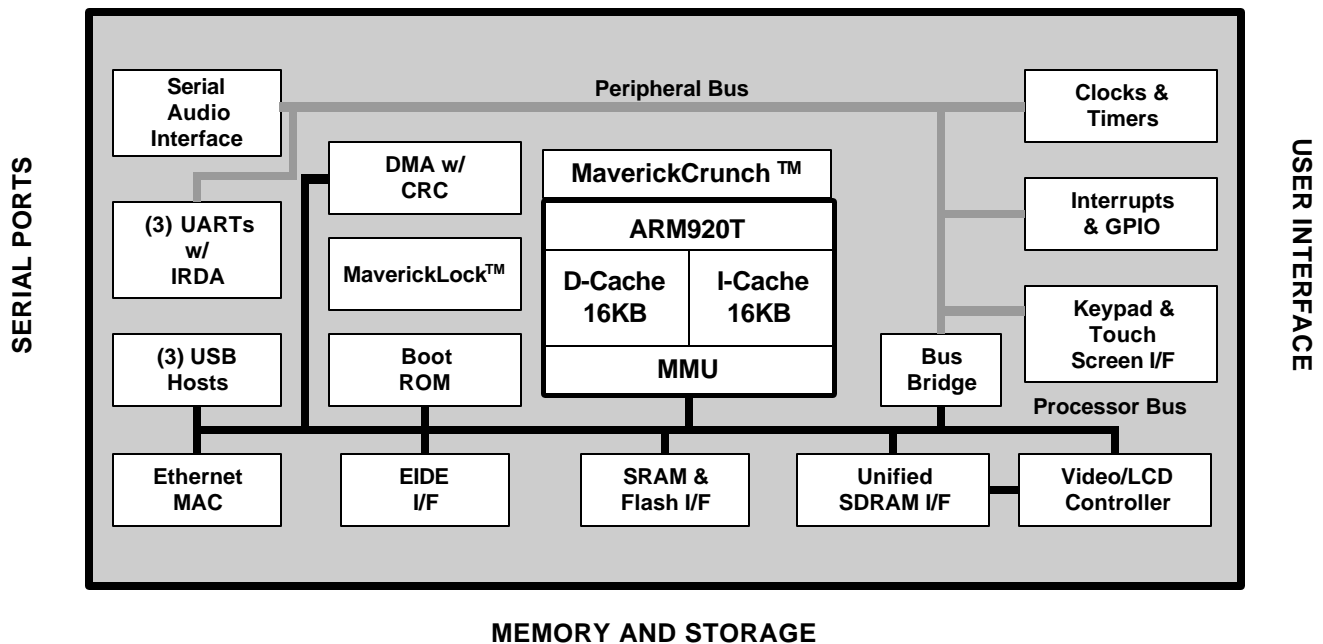

FEATURES *(cont.)*

■ Integrated Peripheral Interfaces

- EIDE (up to 2 devices)
- 1/10/100Mbps Ethernet MAC
- Three 16550 compatible UARTs
- Three-port USB Host
- IRDA Interface
- 32-bit SDRAM Interface up to 4 banks
- 32/16-bit SRAM/FLASH/ROM
- EEPROM Interface

■ Internal Peripherals

- Real-time Clock with software Trim
- Eight Direct Memory Access (DMA) Channels with Cyclic Redundancy Check (CRC) Generation
- Dual PLL controls all clock domains
- Watchdog Timer
- Interrupt Controller
- Four general purpose 16-bit timers
- 40-bit Debug Timer
- Boot ROM

■ Package

- 352 pin PBGA

OVERVIEW *(cont.)*

The ARM920T microprocessor core with separate 16Kbyte, 64-way set-associative instruction and data caches is augmented by the MaverickCrunch™ co-processor enabling faster than real-time compression of audio CDs. The proprietary MaverickLock™ technology exceeds security requirements set forth by SDMI to protect music content. It may also be used to protect proprietary firmware, transactions, and other digital content.

A high-performance 1/10/100Mbps Ethernet Media Access Controller (EMAC) is included along with

external interfaces to SPI and I²S audio, LCD, IDE storage peripherals, keypad, and touchscreen. A three-port USB host and three UARTs are included as well.

The EP9213 is a high-performance, low-power RISC-based single-chip computer built around an ARM920T microprocessor core with a maximum operating clock rate of 200MHz. The ARM core is operated from a 2.5V supply, while the I/O operates at 3.3V with power between 350mW and 1000mW dependent on speed.

Contacting Cirrus Logic Support

For a complete listing of Direct Sales, Distributor, and Sales Representative contacts, visit the Cirrus Logic web site at:
<http://www.cirrus.com/corporate/contacts/>

Preliminary product information describes products which are in production, but for which full characterization data is not yet available. Advance product information describes products which are in development and subject to development changes. Cirrus Logic, Inc. has made best efforts to ensure that the information contained in this document is accurate and reliable. However, the information is subject to change without notice and is provided "AS IS" without warranty of any kind (express or implied). No responsibility is assumed by Cirrus Logic, Inc. for the use of this information, nor for infringements of patents or other rights of third parties. This document is the property of Cirrus Logic, Inc. and implies no license under patents, copyrights, trademarks, or trade secrets. No part of this publication may be copied, reproduced, stored in a retrieval system, or transmitted, in any form or by any means (electronic, mechanical, photographic, or otherwise) without the prior written consent of Cirrus Logic, Inc. Items from any Cirrus Logic website or disk may be printed for use by the user. However, no part of the printout or electronic files may be copied, reproduced, stored in a retrieval system, or transmitted, in any form or by any means (electronic, mechanical, photographic, or otherwise) without the prior written consent of Cirrus Logic, Inc. Furthermore, no part of this publication may be used as a basis for manufacture or sale of any items without the prior written consent of Cirrus Logic, Inc. The names of products of Cirrus Logic, Inc. or other vendors and suppliers appearing in this document may be trademarks or service marks of their respective owners which may be registered in some jurisdictions. A list of Cirrus Logic, Inc. trademarks and service marks can be found at <http://www.cirrus.com>

Processor Core - ARM920T

The ARM920T is a Harvard architecture processor with separate 16Kbyte instruction and data caches with an 8-word line length. The processor utilizes a five-stage pipeline consisting of fetch, decode, execute, memory and write stages. Key features include:

- ARM (32-bit) and Thumb (16-bit compressed) instruction sets
- 32-bit Advanced Micro-Controller Bus Architecture (AMBA)
- 16Kbyte Instruction Cache with lockdown
- 16Kbyte Data Cache (programmable write-through or write-back) with lockdown
- MMU for Microsoft® Windows® CE and other operating systems
- Translation Look Aside Buffers with 64 Data and 64 Instruction Entries
- Programmable Page Sizes of 64Kbyte, 4Kbyte, and 1Kbyte
- Independent lockdown of TLB Entries

MaverickCrunch™ Math Engine

The MaverickCrunch Engine is a mixed-mode coprocessor designed primarily to accelerate the math processing required to rapidly encode digital audio formats. It accelerates single and double precision integer and floating point operations plus an integer multiply-accumulate (MAC) instruction that is considerably faster than the ARM920T's native MAC instruction. The ARM920T coprocessor interface is utilized thereby sharing its memory interface and instruction stream. Hardware forwarding and interlock allows the ARM to handle looping and addressing while MaverickCrunch handles computation. Features include:

- IEEE-754 single and double precision floating point
- 32/64-bit integer
- Add/multiply/compare
- Integer MAC 32-bit input with 72-bit accumulate
- Integer Shifts
- Floating point to/from integer conversion
- Sixteen 64-bit register files
- Four 72-bit accumulators

MaverickLock™ Security

MaverickLock security is a generalized architecture consisting of boot ROM, laser fuses, and proprietary circuitry for secure hardware initialization. In the context of this environment, the EP9312 supports multiple digital rights management content protection

from several security vendors including Microsoft® and InterTrust®. It exceeds all the requirements set forth by SDMI and allows for protection of object code as well as content. Features include:

- 256 bits of laser fuses for permanent IDs and passwords
- Security boot firmware and private passwords are “invisible” except when the IC is “locked”
- Each instantiation of the system software may be uniquely encoded and protected by using the private ID
- Multiple security vendors can co-exist in the same system

General Purpose Memory Interface (SDRAM, SRAM, ROM, FLASH)

The Maverick 9312 features a unified memory address model where all memory devices are accessed over a common address/data bus. A separate internal port is dedicated to the read-only LCD refresh engine, while the rest of the memory accesses are performed via the Advanced High Performance Bus (AHB). The memory controller supports both 16- and 32-bit devices and accommodates a 16-bit boot ROM concurrently with 32-bit SDRAM memory.

- 1-4 banks of 32-bit 66 or 100MHz SDRAM
- One internal port dedicated to the LCD Refresh Engine (Read Only)
- One internal port dedicated to the rest of the chip via the AHB
- Address and data bus shared between SDRAM, SRAM, ROM, and FLASH memory
- Either NAND or NOR FLASH memory supported

Table A. General Purpose Memory Interface Pin Assignments

Pin Mnemonic	I/O	Pin Description
SDCLK	O	SDRAM Clock
SDCLKEN	O	SDRAM Clock Enable
SDCSn[3:0]	O	SDRAM Chip Selects 3-0
RASn	O	SDRAM RAS
CASn	O	SDRAM CAS
SDWEn	O	SDRAM Write Enable
CSn[7:0]	O	Chip Selects 7-0
AD[25:0]	O	Address Bus 25-0
DA[31:0]	I/O	Data Bus 31-00
DQMn[3:0]	O	SDRAM Output Enables / Data Masks

Table A. General Purpose Memory Interface Pin Assignments

Pin Mnemonic	I/O	Pin Description
WRn	O	SRAM Write Strobe
RDn	O	SRAM Read/OE Strobe
WAITn	I	Wait Input

IDE Interface

The IDE Interface provides an industry-standard connection to two AT Packet Interface (ATAPI) compliant devices. Each device may be controlled by any of the 8 DMA controllers. The IDE port will attach to a master and a slave device. The internal DMA controller performs all data transfers using the Multiword DMA and Ultra DMA modes. The interface supports the following operating modes:

- PIO Mode 4
- Multiword DMA Mode 2
- Ultra DMA Mode 2

Table B. IDE Interface Pin Assignments

Pin Mnemonic	I/O	Pin Description
DD[15-0]	I/O	IDE Data bus
IDEDA[2-0]	O	IDE Device address
IDECSn[0,1]	O	IDE Chip Select 0 and 1
DIORn	O	IDE Read Strobe
IDORWn	O	IDE Write Strobe
DMACKn	O	IDE DMA acknowledge

LCD Interface

The LCD interface provides data and interface signals for a variety of display types. It features fully programmable video interface timing for non-interlaced flat panel or dual scan displays. Resolutions up to 1024x768 are supported from a unified SDRAM based frame buffer. A 6-bit DAC provides an analog DC voltage output for the LCD panel contrast control. LCD specific features include:

- Provides timing and interface signals for digital LCD and TFT displays
- Fully programmable for either non-interlaced or dual-scan color and grayscale flat panel displays
- Dedicated data path to SDRAM controller for improved system performance
- Pixel depths of 4-, 8-, 16-, or 18-bits per pixel or 256 levels of grayscale
- Hardware Cursor up to 64 x 64 x 2 pixels
- 256 x 18 Color Lookup Table

- Hardware Blinking
- 6-bit Contrast DAC

Table C. LCD Interface Pin Assignments

Pin Mnemonic	I/O	Pin Description
SPCLK	I/O	Pixel Clock
P[17:0]	O	Pixel Data Bus [17:0]
HSYNC/LP	O	Horizontal Synchronization/Line Pulse
VCSYNC/FP	O	Vertical or Composite Synchronization / Frame Pulse
BLANK	O	Composite Blank
BRIGHT	O	Pulse Width Modulated Brightness
CDACO	O	Contrast DAC Output

Ethernet Media Access Controller (EMAC)

The MAC subsystem is compliant with the ISO/TEC 8802-3 topology for a single shared medium with several stations. Multiple MII-compliant PHYs are supported. Features include:

- Supports 1/10/100Mbps transfer rates for home/small-business/large-business applications
- Interfaces to an off-chip PHY through industry standard Media Independent Interface (MII)
- May be configured entirely by the driver or through auto-negotiation

Table D. Ethernet Media Access Controller Pin Assignments

Pin Mnemonic	I/O	Pin Description
MDC	O	Management Data Clock
MDIO	I/O	Management Data I/O
RXCLK	I	Receive Clock
MIIRXD[3:0]	I	Receive Data
RXDVAL	I	Receive Data Valid
RXERR	I	Receive Data Error
TXCLK	I/O	Transmit Clock
MIITXD[3:0]	O	Transmit Data
TXEN	O	Transmit Enable
TXERR	O	Transmit Error
CRS	I	Carrier Sense
CLD	I	Collision Detect

Touch Screen Interface with 12-bit Analog-to-Digital Converter (ADC)

The touch screen interface performs all sampling, averaging, ADC range checking, and control for a wide variety of analog resistive touch screens. This controller only interrupts the processor when a meaningful change occurs. The touch screen hardware may be disabled and the switch matrix and ADC controlled directly if desired. Features include:

- Supports 4-, 5-, 7-, or 8-wire analog resistive touch screens
- Unused lines may be used for temperature sensing or other functions
- Touch screen interrupt function is provided.

Table E. Touch Screen Interface with 12-bit Analog-to-Digital Converter Pin Assignments

Pin Mnemonic	I/O	Pin Description
Xp, Xm	O	Touch screen ADC X Axis
Yp, Ym	O	Touch screen ADC Y Axis
SXp, SXm	I	Touch screen ADC X Axis Voltage Feedback
SYp, SYm	I	Touch screen ADC Y Axis Voltage Feedback

64-Keypad Interface

The keypad circuitry scans an 8x8 array of 64 normally open, single pole switches. Any one or two keys depressed will be de-bounced and decoded. An interrupt is generated whenever a stable set of depressed keys is detected. If the keypad is not utilized, the 16 column/row pins may be used as general purpose I/O.

- Provides scanning, debounce and decoding for a 64-key array
- Scans an 8-row by 8-column matrix
- Up to 2 keys may be decoded at once
- An interrupt is generated when new stable key is determined
- Also generates a 3-key reset interrupt

Table F. 64-Key Keypad Interface Pin Assignments

Pin Mnemonic	I/O	Pin\ Description	Alternative Usage
COL[7:0]	I	Key Matrix Column Inputs	General Purpose I/O
ROW[7:0]	O	Key Matrix Row Inputs	General Purpose I/O

Audio Interfaces (SPI and I²S)

Two SPI ports are independently configured as masters or slaves, supporting the Motorola[®], National Semiconductor[®], and Texas Instruments[®] signaling protocols. SPI port 0 may be configured as an Inter-IC Sound (I²S) port.

- Two SPI Ports
- Alternative I²S Port

Table G. Audio Interfaces Pin Assignments

Pin Mnemonic	I/O	Pin Description	Alternative Usage (I ² S)
SCLK[0]	O	SPI[0] Clock	SCLK
SFRM[0]	O	SPI[0] Frame Clock	LRCLK
SSPRX(0)	I	SPI[0] Input	SDI
SSPTX(0)	O	SPI[0] Output	SDO
SCLK[1]	O	SPI[1] Clock	None
SFRM[1]	O	SPI[1] Frame Clock	None
SPRX(1)	I	SPI[1] Input	None
SSPTX(1)	O	SPI[1] Output	None
ARSTn	O	-	MCCLK

Triple Port USB Host

The USB host controller is configured for three root hub ports and features integrated transceivers for each port. The controller complies with the Open Host Controller Interface (OHCI) Specification for USB, Revision 1.1.

Table H. Triple Port USB Host Pin Assignments

Pin Mnemonic	I/O	Pin Name - Description
USBp[2:0]	I/O	USB Positive signals
USBm[2:0]	I/O	USB Negative Signals
USBVDD[1:0]	NA	USB Power
USBGND[1:0]	NA	USB Ground

Universal Asynchronous Receiver/Transmitters (UARTs)

Three 16550-compatible UARTs are supplied. Two provide asynchronous (High-level Data Link Control) HDLC protocol support for full duplex transmit and receive. The HDLC receiver handles framing, address matching, CRC checking, control-octet transparency, and optionally passes the CRC to the host at the end of the packet. The HDLC transmitter handles framing, CRC generation, and control-octet transparency. The host must assemble the frame in memory before transmission. The HDLC receiver and transmitter use the UART FIFOs to buffer the data streams. A third IrDA[®] compatible UART is also supplied.

- UART1 supports modem bit rates up to 115.2Kbps, supports HDLC and includes a 16 byte FIFO for receive and a 16 byte FIFO for transmit. Interrupts are generated on Rx, Tx and modem status change.
- UART2 contains an IrDA encoder operating at either the slow (115Kbps) or fast (4Mbps) IR data rates
- UART3 supports HDLC link layer protocol for transmission over synchronous networks

Table I. Universal Asynchronous Receiver / Transmitters Pin Assignments

Pin Mnemonic	I/O	Pin Name - Description
TXD[0]	O	UART1 Transmit
RXD[0]	I	UART1 Receive
CTS _n	I	UART1 Clear To Send / Transmit Enable
DSR _n /DCD _n	I	UART1 Data Set Ready / Data Carrier Detect
DTR _n	O	UART1 Data Terminal Ready
RTS _n	O	UART1 Ready To Send
EGPIO[0]/RI	I	UART1 Ring Indicator
TXD[1]/SIROUT	O	UART2 Transmit / IrDA Output
RXD[1]/SIRIN	I	UART2 Receive / IrDA Input
TXD[2]	O	UART3 Transmit
RXD[2]	I	UART3 Receive
EGPIO[3]/TEN	O	UART3 Transmit Enable

Interrupt Controller

The interrupt controller has 56 interrupts to generate an Interrupt Request (IRQ) or Fast Interrupt Request (FIQ) signal to the processor core. Thirty-two hardware priority assignments provided for assisting IRQ

vectoring, and two levels are provided for FIQ vectoring. This allows time critical interrupts to be processed in the shortest time possible while maintaining RPS compatibility. Internal interrupts may be programmed as active high or active low level sensitive inputs. External interrupts may be programmed as active high level sensitive, active low level sensitive, rising edge triggered, falling edge triggered, or triggered from both.

- Supports 56 interrupts from a variety of sources (such as UARTs, GPIO, and key matrix.)
- Routes interrupt sources to either the ARM920T's IRQ or FIQ (Fast IRQ) inputs
- Four dedicated off-chip interrupt lines operate as either edge triggered or level sensitive interrupts
- Any of the 16 GPIO lines maybe configured to generate interrupts
- Software supported priority mask for all FIQs and IRQs

Table J. Interrupt Controller Pin Assignment

Pin Mnemonic	Pin Name - Description
INT[3:0]	External Interrupt 3-0

Real-Time Clock with Software Trim

- Provides software controlled digital compensation of the 32.768KHz crystal oscillator
- Accurate to +/- 5sec/month

Table K. Real-Time Clock with Pin Assignments

Pin Mnemonic	Pin Name - Description
RTCXTALI	Real-Time Clock Oscillator Input
RTCXTALO	Real-Time Clock Oscillator Output
RTCVDD	Real-Time Clock Oscillator Power
RTCGND	Real-Time Clock Oscillator Ground

Timers

- Watchdog Timer insures proper operation by requiring periodic attention to prevent a reset on time out
- Four 16-bit timers operate as free running down-counters or as periodic timers for fixed interval interrupts and have a range of 0.03ms to 4.27seconds
- 32-bit timer plus 6-bit prescale counter has a range of 0.03 μs to 73.3hours
- 40-bit debug timer plus 6-bit prescale counter has a range of 1.0 μs to 12.7 days

PLL and Clocking

- Processor and Peripheral Clocks operate from a single 3.6864MHz crystal
- Real-Time Clock operates from a 32.768KHz crystal

Table L. PLL and Clocking Pin Assignments

Pin Mnemonic	Pin Name - Description
XTALI	Main Oscillator Input
XTALO	Main Oscillator Output
PLLVD	Main Oscillator Power
PLLGND	Main Oscillator Ground

Two-Wire Interface With EEPROM Support

- Communication and control for EEPROM devices.
- EEPROM Controller may download device configuration information upon chip reset

Table M. Two-Wire Port with EEPROM Support Pin Assignments

Pin Mnemonic	Pin Name - Description	Alternative Usage
EECLK	EEPROM / Two-Wire Interface Clock	General Purpose I/O
EEDATA	EEPROM / Two-Wire Interface Data	General Purpose I/O
SLA[1:0]	External Power Switch Control	General Purpose I/O

Dual LED Drivers

- Two pins assigned specifically to drive LEDs

Table N. Dual LED Pin Assignments

Pin Mnemonic	Pin Name - Description	Alternative Usage
GRLED	Green LED	General Purpose I/O
REDLED	Red LED	General Purpose I/O

General Purpose Input/Output (GPIO)

- 16 EGPIO pins may individually be used as an output, an input, or an interrupt input
- 23 pins may alternatively be used as input, output, or open-drain pins but do not support interrupts:
 - Key Matrix ROW[7:0], COL[7:0]
 - Ethernet MDIO

- Both LED Outputs
- EEPROM Clock and Data
- SLA [1:0]
- 6 pins may alternatively be used as inputs only:
 - CTSn, DSRn/DCDn
 - 4 Interrupt Lines
- 2 pins may alternatively be used as outputs only:
 - RTSn
 - ARSTn

Table O. General Purpose Input/Output Pin Assignment

Pin Mnemonic	Pin Name - Description
EGPIO[15:0]	Expanded General Purpose Input / Output Pins w/ Interrupts

Reset and Power Management

- The chip may be reset through the PRSTn pin or through the open drain common reset pin, RSTOn
- Clocks are managed on a peripheral-by-peripheral basis and may be turned off to conserve power
- The processor clock is dynamically adjustable from 0 to 200MHz

Table P. Reset and Power Management Pin Assignments

Pin Mnemonic	Pin Name - Description
PRSTn	Power On Reset
RSTOn	User Reset In/Out – Open Drain – Preserves Real Time Clock value

Hardware Debug Interface

- JTAG – Allows use of ARM's Multi-ICE or other in-circuit emulators

Table Q. Hardware Debug Interface

Pin Mnemonic	Pin Name - Description
TCK	JTAG Clock
TDI	JTAG Data In
TDO	JTAG Data Out
TMS	JTAG Test Mode Select

8-Channel DMA Controller with Four Hardware CRC Generators

The DMA module contains 8 separate DMA channels, Four Linear Feedback Shift Registers (LFSR), an 8-way Arbiter, a shared AHB bus master macrocell, a shared AHB register slave macrocell. Each DMA channel is connected to the 16-bit DMA request bus.

The request bus is a collection of requests from system resources such as UARTS. Each DMA channel can used independently or dedicated to any request signal. Each of the four LFSRs can also be dedicated to generate CRCs for their respective DMA channel or initialized by any AHB bus master as a separate entity. For each DMA channel, source and destination addressing can be independently programmed to increment, decrement, or

stay at the same value. All DMA addresses are physical, not virtual addresses.

- 8 DMA Controllers may each be used independently or dedicated to a requestor
- CRC Generators may be hardware connected to DMA Channels or used independently
- There are four CRC algorithms available:
 - CRC-16
 - CRC-16 Reverse
 - CRC-CCITT, or CRC-CCITT Reverse
 - Programmable divisor polynomial allows customized CRC algorithms

Internal Boot ROM

- The Internal 16Kbyte ROM allows booting from FLASH memory, ROM or UART.

Absolute Maximum Ratings

(All grounds = 0 V, all voltages with respect to 0 V)

Parameter	Symbol	Min	Max	Unit
Power Supplies	RVDD	-	4.6	V
	RTC_VDD	-	4.6	V
	CVDD	-	4.6	V
	PLL_VDD	-	4.6	V
	ADC_VDD	-	4.6	V
	DAC_VDD	-	4.6	V
	USB_VDD	-	4.6	V
Total Power Dissipation (Note1)		-	2	W
Input Current per Pin, DC (Except supply pins)		-	±10	mA
Output current per pin, DC		-	±50	mA
Digital Input voltage (Note2)		-0.3	V _{dd} +0.3	V
Ambient temperature (power applied) (Note3)		-55	125	°C
Storage temperature		-65	150	°C

- Note:
1. Includes all power generated by AC and/or DC output loading.
 2. The power supply pins are at recommended maximum values.
 3. At ambient temperatures above 70° C, total power dissipation must be limited to less than TBD Watts.

WARNING: Operation beyond these limits may result in permanent damage to the device.
Normal operation is not guaranteed at these extremes.

Recommended Operating Conditions

(All grounds = 0 V, all voltages with respect to 0 V)

Parameter	Symbol	Min	Typ	Max	Unit
Power Supplies (Note4)	RVDD	TBD	3.3	TBD	V
	RTC_VDD	TBD	3.3	TBD	V
	CVDD	TBD	2.5	TBD	V
	PLL_VDD	TBD	2.5	TBD	V
	ADC_VDD	TBD	3.3	TBD	V
	DAC_VDD	TBD	3.3	TBD	V
	USB_VDD	TBD	3.3	TBD	V
Operating Ambient Temperature	T_A	0	25	70	°C

Note: 4. Minimum voltage on RTC_VDD is the level guaranteed to continue real time clock operation on battery power.

DC Characteristics

($T_A = 0$ to 70°C ; CVDD = PLL_VDD= 2.5; RTC_VDD = RVDD = 3.3V;
All grounds = 0 V; all voltages with respect to 0 V unless otherwise noted)

Parameter	Symbol	Min	Max	Unit
High level output voltage $I_{out} = -5\text{ mA}$ (Note5)	V_{oh}	$0.9 \times V_{dd}$	-	V
Low level output voltage $I_{out} = 5\text{ mA}$	V_{ol}	-	$0.1 \times V_{dd}$	V
High level input voltage (Note6)	V_{ih}	$0.65 \times V_{dd}$	$V_{dd} + 0.3$	V
Low level input voltage (Note6)	V_{il}	-0.3	$0.35 \times V_{dd}$	V
High level leakage current $V_{in} = 3.3\text{ V}$ (Note6)	I_{ih}	-	10	μA
Low level leakage current $V_{in} = 0$ (Note6)	I_{il}	-	-10	μA

Parameter	Min	Typ	Max	Unit
Power Supply Pins (Outputs Unloaded)				
Power Supply Current: RTC_VDD	-	TBD	TBD	μA
CVDD/PLL_VDD Total	-	200	TBD	mA
RVDD	-	20	TBD	mA
Low-Power Mode Supply Current	-	TBD	-	mA

Note: 5. For open drain pins, high level output voltage is dependent on external pull-up used and number of attached gates.
6. All inputs that do not include internal pull-ups or pull-downs, must be externally driven for proper operation. If an input is not driven, it should be tied to power or ground, depending on the particular function. If an I/O pin is not driven and programmed as an input, it should be tied to power or ground through its own resistor.

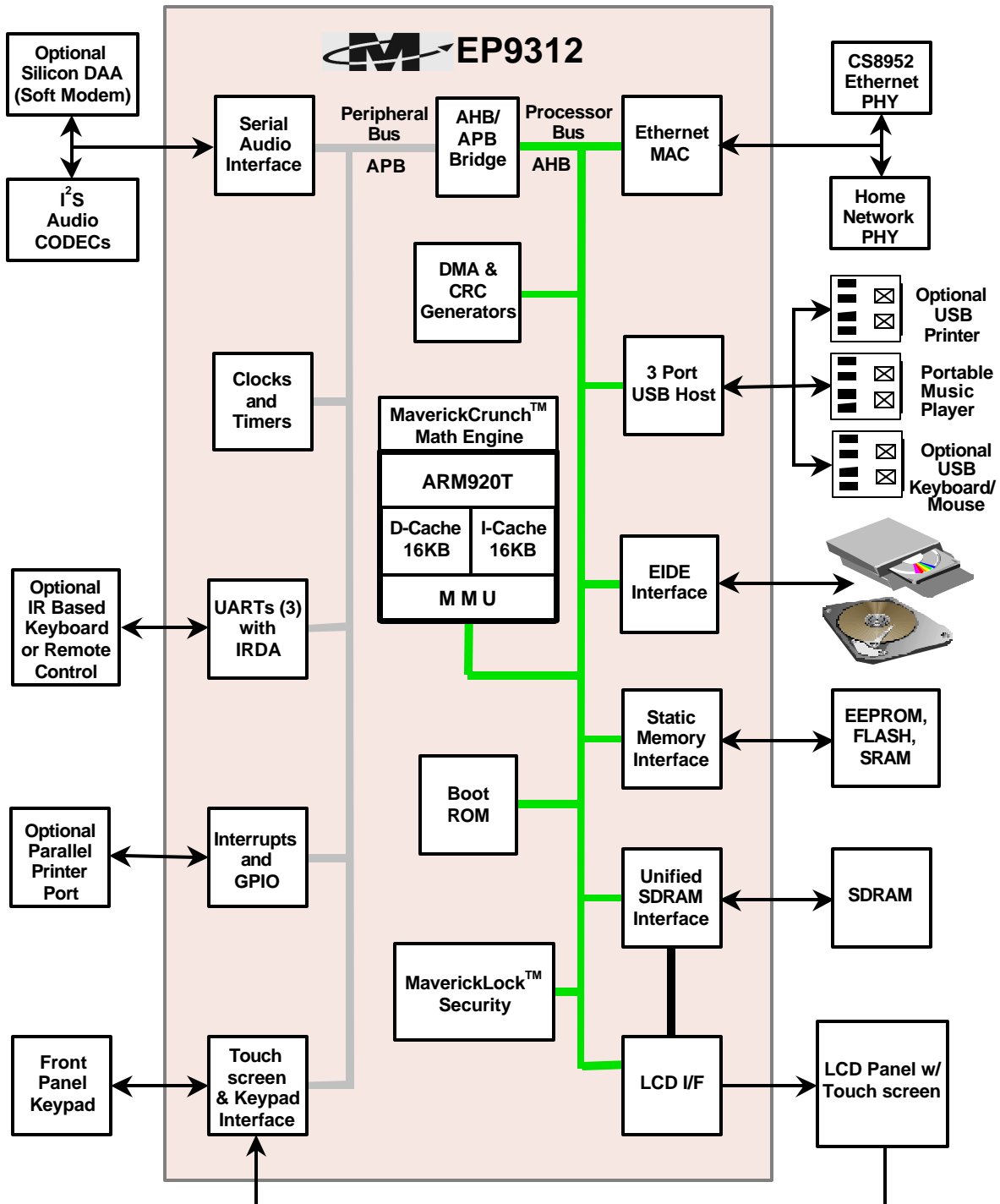

Figure 1. Audio Jukebox Block Diagram

352 Pin BGA Package Outline

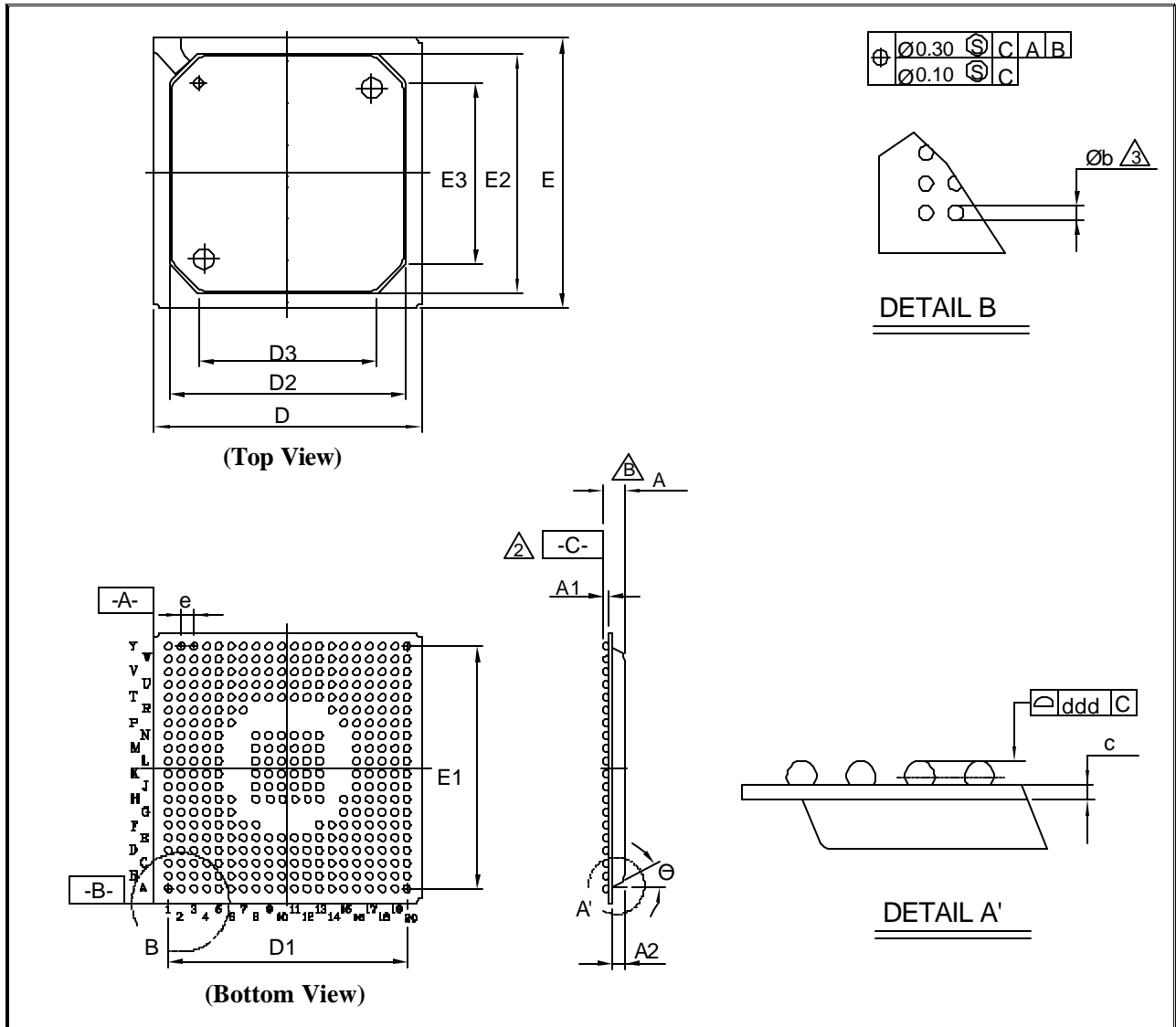

Figure 2. 352 Pin PBGA Pin Diagram

Table R. 352 Pin Diagram Dimensions

Symbol	dimension in mm			dimension in inches		
	MIN	NOM	MAX	MIN	NOM	MAX
A	2.20	2.30	2.50	0.087	0.092	0.098
A1	---	0.60	---	---	0.024	---
A2	1.12	1.17	1.22	0.044	0.046	0.048
b	---	0.75	-----	-----	0.030	-----
c	0.51	0.56	0.61	0.020	0.022	0.024
D	26.80	27.00	27.20	1.055	1.063	1.071
D1	-----	24.13	-----	-----	0.950	-----
D2	23.80	24.00	24.20	0.937	0.945	0.953
D3	17.95	18.00	18.05	0.707	0.709	0.711
E	26.80	27.00	27.20	1.055	1.063	1.071
E1	-----	24.13	-----	-----	0.950	-----
E2	23.80	24.00	24.20	0.937	0.945	0.953
E3	17.95	18.00	18.05	0.707	0.709	0.711
e	-----	1.27	-----	-----	0.050	-----
ddd	-----	-----	0.15	-----	-----	0.006
θ	30° TYP			30° TYP		

- Note:
1. CONTROLLING DIMENSION: MILLIMETER.
 2. PRIMARY DATUM C AND SEATING PLANE ARE DEFINED BY THE SPHERICAL CROWNS OF THE SOLDER BALLS.
 3. DIMENSION b IS MEASURED AT THE MAXIMUM SOLDER BALL DIAMETER, PARALLEL TO PRIMARY DATUM C.
 4. THERE SHALL BE A MINIMUM CLEARANCE OF 0.25 mm BETWEEN THE EDGE OF THE SOLDER BALL AND THE BODY EDGE.
 5. REFERENCE DOCUMENT: JEDEC MO-151, BAL-2

352 Pin BGA Pinout (Top View)

	1	2	3	4	5	6	7	8	9	10	11	12	13	14	15	16	17	18	19	20		
A	RDn	AD24	AD20	DD9	DD6	AD17	CGND	AD13	AD8	AD4	AD3	DA23	DA20	DA15	DA14	DA10	EGPIO10	EGPIO14	DA3	DA2	A	
B	CSn7	CSn6	AD23	AD19	DD8	DD4	AD16	AD14	AD9	AD5	AD1	DA22	DA17	CVDD	DA13	DA9	EGPIO11	EGPIO15	DA1	DA0	B	
C	DD13	DD12	DD11	AD21	AD18	DD7	DD3	AD15	AD10	AD6	AD0	DA21	DA16	DA12	DA7	EGPIO12	DA5	WAITn	GND-RTC	RSTOn	C	
D	CSn4	CSn5	DD14	AD25	AD22	DD10	DD5	CVDD	AD11	AD7	DA19	DA18	DA11	DA6	EGPIO13	DA4	DD1	RTCXTALO	PRSTn	IORDY	D	
E	DA31	CGND	CSn2	CSn3	DSRn	RVDD	RVDD	DD2	AD12	nc	AD2	CGND	DA8	RVDD	RVDD	DD0	RTCXTALI	CSn0	DMACKn	EGPIO0	E	
F	DA26	DA28	DA29	DA30	CSn1	RVDD	RVDD							RVDD	RVDD	RVDD-RTC	ASDI2	DIOWn	EGPIO1	EGPIO4	F	
G	WRn	DA24	DA25	nc	CVDD	RVDD								RVDD	RVDD	ASDI	DIORn	EGPIO3	EGPIO6	EGPIO7	G	
H	SDCSn1	SDCSn2	SDCLKEN	DTRn	DA27			RGND	RGND	RGND	RGND	RGND	RGND			ARSTn	EGPIO5	EGPIO8	EGPIO9	CVDD	H	
J	DQMn3	CASn	RASn	SDCSn0	SDCLK			RGND	RGND	RGND	RGND	RGND	RGND			EGPIO2	COL6	CGND	COL5	COL4	J	
K	DQMn2	DQMn0	SDWEn	DQMn1	SDCSn3			RGND	RGND	RGND	RGND	RGND	RGND			COL7	COL2	COL1	COL3	COL0	K	
L	MIIRXD2	MIIRXD3	RXCLK	MDIO	MDC			RGND	RGND	RGND	RGND	RGND	RGND			nc	ROW4	ROW5	ROW6	ROW7	L	
M	CGND	RXERR	MIIRXD0	MIIRXD1	RXDVAL			RGND	RGND	RGND	RGND	RGND	RGND			RXD2	TXD1	ROW1	ROW2	ROW3	M	
N	TXCLK	MIITXD3	MIITXD2	CVDD	TXERR	RVDD		RGND	RGND	RGND	RGND	RGND	RGND			RVDD	SLA1	RTSn	RXD1	TXD2	ROW0	N
P	MIITXD1	MIITXD0	TXEN	BRIGHT	P16	RVDD										RVDD	RVDD-USB	SLA0	INT3	RXD0	TXD0	P
R	CRS	CLD	nc	P15	P10	RVDD	RVDD	RVDD						RVDD	RVDD	RVDD	USBm1	ABITCLK	GRLED	INT2	CTS	R
T	DD15	BLANK	P14	RVDD-PLL	GND-PLL	P8	P2	VS2	MCADENn	MCRDn	nc	TACK	SCLK1	Yp	nc	GND-DAC	USBp1	ASDO	CGND	CVDD	T	
U	P17	P13	P11	SPCLK	P7	IDECS0n	CVDD	VS1	MCBVD2	MCWRn	TDI	TEST0	INT1	SSPTX1	Xm	sYp	USBm2	USBp0	ASYNC	RDLED	U	
V	P12	XTALO	HSYNC	P6	P0	IDEDA1	READY	MCD2	MCDANn	IOWRn	TCK	TEST1	EEDAT	SSPRX1	Xp	sXm	RVDD-ADC	USBp2	nc	nc	V	
W	XTALI	V_CSYNc	nc	P3	IDECS1n	CGND	MCWAI Tn	MCBVD1	MCREGn	IORDn	MCRES ETn	TMS	EECLK	SFRM1	CGND	sXp	GND-ADC	CDAC0	USBm0	GND-USB	W	
Y	P9	P5	P4	P1	IDEDA0	IDEDA2	MCD1	MCDI R	MCEHn	MCELn	WP	TDO	TREQA	INT0	CVDD	Ym	sYm	RVDD-DAC	RVDD-USB	GND-USB	Y	

The following BGA ball assignment table is sorted in order of ball.

Ball	Signal	Ball	Signal	Ball	Signal	Ball	Signal
A1	RDn	E9	AD[12]	L3	RXCLK	T13	SCLK1
A2	AD[24]	E10	**NC**	L4	MDIO	T14	Yp
A3	AD[20]	E11	AD[2]	L5	MDC	T15	**NC**
A4	DD[9]	E12	CGND	L8	RGND	T16	DAC_GND
A5	DD[6]	E13	DA[8]	L9	RGND	T17	USBp[1]
A6	AD[17]	E14	RVDD	L10	RGND	T18	ASDO
A7	CGND	E15	RVDD	L11	RGND	T19	CGND
A8	AD[13]	E16	DD[0]	L12	RGND	T20	CVDD
A9	AD[8]	E17	RTCXTALI	L13	RGND	U1	P[17]
A10	AD[4]	E18	CSn[0]	L16	**NC**	U2	P[13]
A11	AD[3]	E19	DMACKn	L17	ROW[4]	U3	P[11]
A12	DA[23]	E20	EGPIO[0]	L18	ROW[5]	U4	SPCLK
A13	DA[20]	F1	DA[26]	L19	ROW[6]	U5	P[7]
A14	DA[15]	F2	DA[28]	L20	ROW[7]	U6	IDECs0n
A15	DA[14]	F3	DA[29]	M1	CGND	U7	CVDD
A16	DA[10]	F4	DA[30]	M2	RXERR	U8	VS1
A17	EGPIO[10]	F5	CSn[1]	M3	MIIRXD[0]	U9	MCBVD2
A18	EGPIO[14]	F6	RVDD	M4	MIIRXD[1]	U10	MCWRn
A19	DA[3]	F7	RVDD	M5	RXDVAL	U11	TDI
A20	DA[2]	F14	RVDD	M8	RGND	U12	TEST[0]
B1	CSn[7]	F15	RVDD	M9	RGND	U13	INT[1]
B2	CSn[6]	F16	RTC_VDD	M10	RGND	U14	SSPTX1
B3	AD[23]	F17	ASDI2	M11	RGND	U15	Xm
B4	AD[19]	F18	DIOWn	M12	RGND	U16	sYp
B5	DD[8]	F19	EGPIO[1]	M13	RGND	U17	USBm[2]
B6	DD[4]	F20	EGPIO[4]	M16	RXD[2]	U18	USBp[0]
B7	AD[16]	G1	WRn	M17	TXD[1]	U19	ASYNC
B8	AD[14]	G2	DA[24]	M18	ROW[1]	U20	RDLED
B9	AD[9]	G3	DA[25]	M19	ROW[2]	V1	P[12]
B10	AD[5]	G4	**NC**	M20	ROW[3]	V2	XTALO
B11	AD[1]	G5	CVDD	N1	TXCLK	V3	HSYNC
B12	DA[22]	G6	RVDD	N2	MIITXD[3]	V4	P[6]
B13	DA[17]	G15	RVDD	N3	MIITXD[2]	V5	P[0]
B14	CVDD	G16	ASDI	N4	CVDD	V6	IDEDA[1]
B15	DA[13]	G17	DIORn	N5	TXERR	V7	READY
B16	DA[9]	G18	EGPIO[3]	N6	RVDD	V8	MCD2
B17	EGPIO[11]	G19	EGPIO[6]	N8	RGND	V9	MCDAENn
B18	EGPIO[15]	G20	EGPIO[7]	N9	RGND	V10	IOWRn
B19	DA[1]	H1	SDCSn[1]	N10	RGND	V11	TCK
B20	DA[0]	H2	SDCSn[2]	N11	RGND	V12	TEST[1]
C1	DD[13]	H3	SDCLKEN	N12	RGND	V13	EEDAT
C2	DD[12]	H4	DTRn	N13	RGND	V14	SSPRX1
C3	DD[11]	H5	DA[27]	N15	RVDD	V15	Xp
C4	AD[21]	H8	RGND	N16	SLA[1]	V16	sXm
C5	AD[18]	H9	RGND	N17	RTSn	V17	ADC_VDD
C6	DD[7]	H10	RGND	N18	RXD[1]	V18	USBp[2]
C7	DD[3]	H11	RGND	N19	TXD[2]	V19	**NC**
C8	AD[15]	H12	RGND	N20	ROW[0]	V20	**NC**
C9	AD[10]	H13	RGND	P1	MIITXD[1]	W1	XTALI
C10	AD[6]	H16	ARSTn	P2	MIITXD[0]	W2	V_CSUNC

Ball	Signal	Ball	Signal	Ball	Signal	Ball	Signal
C11	AD[0]	H17	EGPIO[5]	P3	TXEN	W3	**NC**
C12	DA[21]	H18	EGPIO[8]	P4	BRIGHT	W4	P[3]
C13	DA[16]	H19	EGPIO[9]	P5	P[16]	W5	IDEC51n
C14	DA[12]	H20	CVDD	P6	RVDD	W6	CGND
C15	DA[7]	J1	DQMn[3]	P15	RVDD	W7	MCWAITn
C16	EGPIO[12]	J2	CASn	P16	USB_VDD	W8	MCBVD1
C17	DA[5]	J3	RASn	P17	SLA[0]	W9	MCREGn
C18	WAITn	J4	SDCSn[0]	P18	INT[3]	W10	IORDn
C19	RTC_GND	J5	SDCLK	P19	RXD[0]	W11	MCRESETn
C20	RSTOn	J8	RGND	P20	TXD[0]	W12	TMS
D1	CSn[4]	J9	RGND	R1	CRS	W13	EECLK
D2	CSn[5]	J10	RGND	R2	CLD	W14	SFRM1
D3	DD[14]	J11	RGND	R3	**NC**	W15	CGND
D4	AD[25]	J12	RGND	R4	P[15]	W16	sXp
D5	AD[22]	J13	RGND	R5	P[10]	W17	ADC_GND
D6	DD[10]	J16	EGPIO[2]	R6	RVDD	W18	CDACO
D7	DD[5]	J17	COL[6]	R7	RVDD	W19	USBm[0]
D8	CVDD	J18	CGND	R8	RVDD	W20	USB_GND
D9	AD[11]	J19	COL[5]	R13	RVDD	Y1	P[9]
D10	AD[7]	J20	COL[4]	R14	RVDD	Y2	P[5]
D11	DA[19]	K1	DQMn[2]	R15	RVDD	Y3	P[4]
D12	DA[18]	K2	DQMn[0]	R16	USBm[1]	Y4	P[1]
D13	DA[11]	K3	SDWEn	R17	ABITCLK	Y5	IDEDA[0]
D14	DA[6]	K4	DQMn[1]	R18	GRLED	Y6	IDEDA[2]
D15	EGPIO[13]	K5	SDCSn[3]	R19	INT[2]	Y7	MCD1
D16	DA[4]	K8	RGND	R20	CTSn	Y8	MCDIR
D17	DD[1]	K9	RGND	T1	DD[15]	Y9	MCEHn
D18	RTCXTALO	K10	RGND	T2	BLANK	Y10	MCELn
D19	PRSTn	K11	RGND	T3	P[14]	Y11	WP
D20	IORDY	K12	RGND	T4	PLL_VDD	Y12	TDO
E1	DA[31]	K13	RGND	T5	PLL_GND	Y13	TREQA
E2	CGND	K16	COL[7]	T6	P[8]	Y14	INT[0]
E3	CSn[2]	K17	COL[2]	T7	P[2]	Y15	CVDD
E4	CSn[3]	K18	COL[1]	T8	VS2	Y16	Ym
E5	DSRn	K19	COL[3]	T9	MCADEn	Y17	sYm
E6	RVDD	K20	COL[0]	T10	MCRDn	Y18	DAC_VDD
E7	RVDD	L1	MIIRXD[2]	T11	**NC**	Y19	USB_VDD
E8	DD[2]	L2	MIIRXD[3]	T12	TACK	Y20	USB_GND

Maverick™



from
CIRRUS LOGIC