

5358

PHOTOELECTRIC SMOKE DETECTOR WITH INTERCONNECT AND TIMER

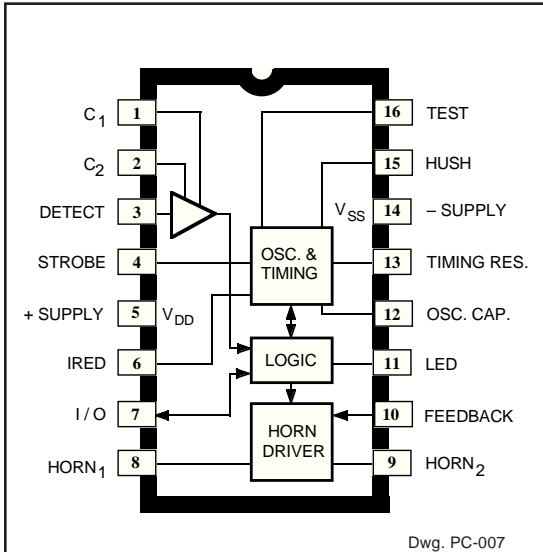

The A5358CA is a low-current BiCMOS circuit providing all of the required features for a photoelectric type smoke detector. This device can be used in conjunction with an infrared photoelectric chamber to sense scattered light from smoke particles. Special features are incorporated in the design to facilitate calibration and testing of the finished detector. The device is designed to comply with Underwriters Laboratories Specification UL217 and British Standard BS 5446, Part 1.

A variable-gain photo amplifier can be directly interfaced to an infrared emitter/detector pair. The amplifier gain levels are determined by two external capacitors that are then internally selected depending on the operating mode. Low gain is selected during standby and timer modes. During a local alarm this low gain is increased (internally) by ~10% to reduce false triggering. High gain is used during the push-button test and during standby to periodically monitor the chamber sensitivity.

The internal oscillator and timing circuitry keeps standby power to a minimum by sensing for smoke every 10 seconds in a 10 μ s window. A special three-stage speedup sensing scheme is incorporated to minimize the time to an audible alarm and also to reduce false triggering. Also, two consecutive cycles of degraded chamber sensitivity are required for a warning signal to occur.

The A5358CA is supplied in a low-cost 16-pin dual in-line plastic package. It is rated for continuous operation over the temperature range of -25°C to +75°C.

ABSOLUTE MAXIMUM RATINGS (Voltages are referenced to V_{SS})

Supply Voltage Range,	
V_{DD}	-0.5 V to +15 V
Input Voltage Range,	
V_{IN}	-0.3 V to $V_{DD} + 0.3$ V
Input Current, I_{IN}	10 mA
Operating Temperature Range,	
T_A	-25°C to +75°C
Storage Temperature Range,	
T_S	-55°C to +125°C

CAUTION: CMOS devices have input static protection but are susceptible to damage if exposed to extremely high static electrical charges.

FEATURES

- Interconnect Up to 50 Detectors
- Piezoelectric Horn Driver
- All Internal Low-Battery Detection
- Power-ON Reset
- Internal Timer & Control for Reduced Sensitivity
- Built-In Circuits to Reduce False Triggering
- 6 V to 12 V Operating Voltage Range
- ESD-Protection Circuitry on All Pins

Always order by complete part number: **A5358CA** .

5358
PHOTOELECTRIC SMOKE DETECTOR
with INTERCONNECT and TIMER

FUNCTIONAL BLOCK DIAGRAM

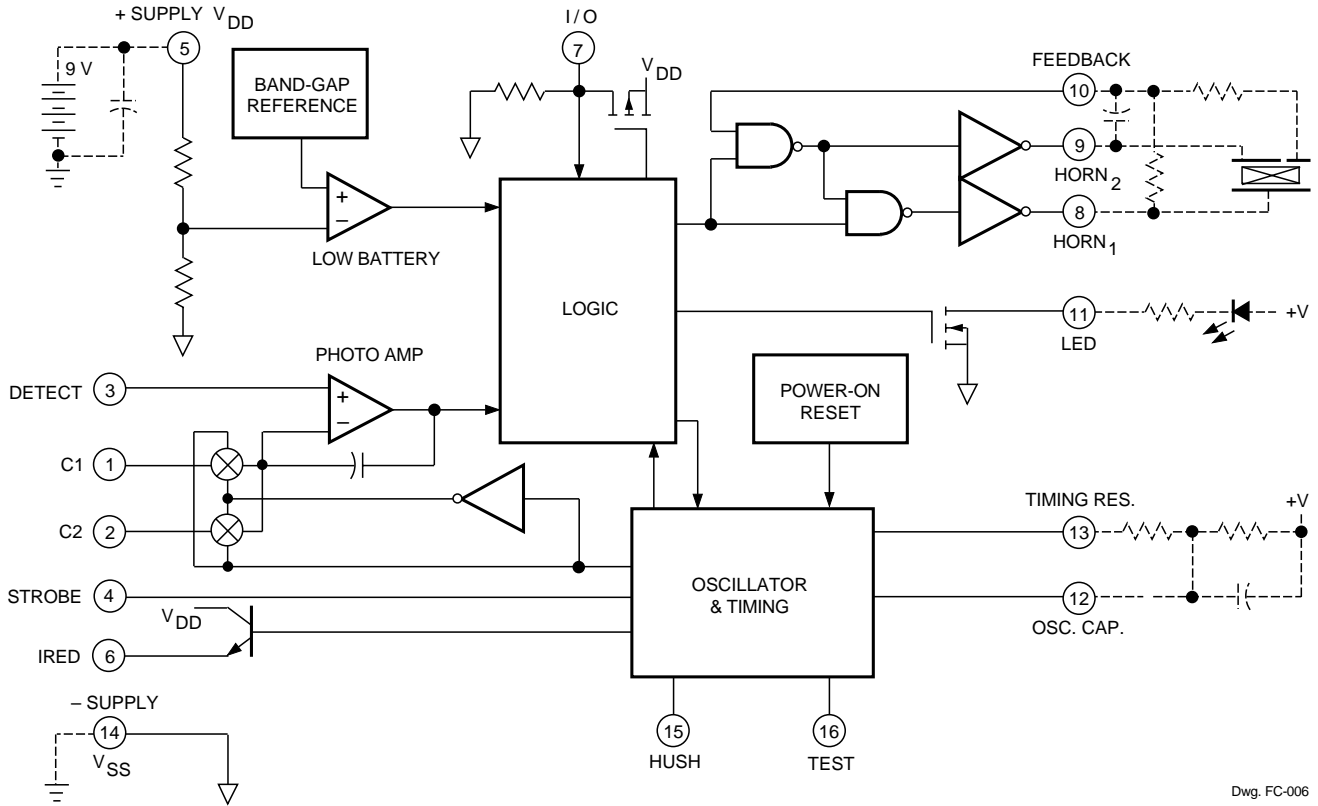

Dwg. FC-006

5358
PHOTOELECTRIC SMOKE DETECTOR
with INTERCONNECT and TIMER

DC ELECTRICAL CHARACTERISTICS at $T_A = -25^{\circ}\text{C}$ to $+75^{\circ}\text{C}^*$, $V_{SS} = 0\text{ V}$, in typical application (unless otherwise noted).

Characteristic	Symbol	Test Conditions	Test Pin	V_{DD}	Limits			Units
					Min.	Typ.	Max.	
Supply Voltage Range	V_{DD}		5	–	6.0	–	12	V
Operating Supply Current	I_{DD}	Average Standby Configured per Figure 1	5	12	–	–	12	μA
		During Strobe ON, I_{RED} OFF, Configured per Figure 1	5	12	–	–	2.0	mA
		During Strobe ON, I_{RED} ON, Configured per Figure 1	5	12	–	–	3.0	mA
Low-Level Input Voltage	V_{IL}		7	9	–	–	1.5	V
			10	9	–	–	2.7	V
			16	9	–	–	7.0	V
			15	9	–	–	0.5	V
High-Level Input Voltage	V_{IH}		7	9	3.2	–	–	V
			10	9	6.3	–	–	V
			16	9	8.5	–	–	V
			15	9	1.6	–	–	V
Input Leakage High	I_{IH}	$V_{IN} = V_{DD}$, Strobe Active, Pin 12 @ V_{DD}	1, 2	12	–	–	100	nA
		$V_{IN} = V_{DD}$	3, 10, 12	12	–	–	100	nA
Input Leakage Low	I_{IL}	$V_{IN} = V_{ST}$, Strobe Active, Pin 12 @ V_{DD}	1, 2, 3	12	–	–	-100	nA
		$V_{IN} = V_{SS}$	10, 12	12	–	–	-100	nA
			15, 16	12	–	–	-1.0	μA
Input Pull-Down Current	I_{IN}	$V_{IN} = V_{DD}$	16, 15	9	0.25	–	10	μA
		No Local Smoke, $V_{IN} = V_{DD}$	7	9	20	–	80	μA
		No Local Smoke, $V_{IN} = 17\text{ V}$	7	12	–	–	140	μA
Low-Level Output Voltage	V_{OL}	$I_O = 10\text{ mA}$	11	6.5	–	–	0.6	V
		$I_O = 16\text{ mA}$	8, 9	6.5	–	–	1.0	V
		$I_O = 5\text{ mA}$	13	6.5	–	0.5	–	V
High-Level Output Voltage	V_{OH}	$I_O = -16\text{ mA}$	8, 9	6.5	5.5	–	–	V
Strobe Output Voltage	V_{ST}	Inactive $I_O = -1\text{ }\mu\text{A}$	4	12	$V_{DD} - 0.1$	–	–	V
		Active, $I_O = 100\text{ }\mu\text{A}$ to $500\text{ }\mu\text{A}$	4	9	$V_{DD} - 5.25$	–	$V_{DD} - 4.75$	V

Continued...

5358

PHOTOELECTRIC SMOKE DETECTOR

with INTERCONNECT and TIMER

DC ELECTRICAL CHARACTERISTICS, continued

Characteristic	Symbol	Test Conditions	Test Pin	V _{DD}	Limits			Units
					Min.	Typ.	Max.	
Line Regulation	$\Delta V_{ST(\Delta V_{DD})}$	Active, V _{DD} = 6 V to 12 V	4	-	-	-60	-	dB
Strobe Temperature Coeff.	α_{ST}	V _{DD} = 6 V to 12 V	4	-	-	0.01	-	%/°C
I _{RED} Output Voltage	V _{IRED}	Inactive I _O = 1 μ A, T _A = +25°C	6	12	-	-	0.1	V
		Active I _O = -6 mA, T _A = +25°C	6	9	2.85	3.1	3.35	V
Line Regulation	$\Delta V_{IRED(\Delta V_{DD})}$	Active, V _{DD} = 6 V to 12 V	6	-	-	-35	-	dB
I _{RED} Temperature Coefficient	α_{IRED}	V _{DD} = 6 V to 12 V	6	-	-	+0.40	-	%/°C
High-Level Output Current	I _{OH}	V _{DD} = Alarm, I/O active, V _O = V _{DD} - 2 V	7	9	-4.0	-	-	mA
OFF Leakage Current High	I _{OZ}	V _O = V _{DD}	11, 13	12	-	-	1.0	μ A
OFF Leakage Current Low	I _{OZ}	V _O = V _{SS}	11, 13	12	-	-	-1.0	μ A
Low V _{DD} Alarm Threshold	V _{DD(th)}		5	-	6.9	7.2	7.5	V
Common Mode Voltage	V _{IC}	Any Alarm Condition	1, 2, 3	-	V _{DD} - 4	-	V _{DD} - 2	V
Smoke Comparator Ref. Volt.	V _{REF}	Any Alarm Condition	Internal	-	V _{DD} - 3.7	-	V _{DD} - 3.3	V

* Limits over the operating temperature range are based on characterization data.

Characteristics are production tested at +25°C only.

Typical values are at +25°C and are given for circuit design information only.

AC ELECTRICAL CHARACTERISTICS at T_A = -25°C to +75°C*, V_{SS} = 0 V, in typical application (unless otherwise noted).

Characteristic	Symbol	Test Conditions	Test Pin	V _{DD}	Limits			Units
					Min.	Typ.	Max.	
Oscillator Period	t _{osc}		12	9	9.4	10.5	11.5	ms
Led Pulse Period	t _{led1}	No Local or Remote Smoke	11	9	39	-	48	s
	t _{led4}	Remote Smoke Only	11	9	None	-	-	-
	t _{led6}	Local Smoke or Test	11	9	0.60	0.67	0.74	s
	t _{led7}	Timer Mode, No Alarm	11	9	9.67	10.8	11.8	s
Led Pulse Width	t _{w(led)}		11	9	9.5	-	11.5	ms

Continued...



5358**PHOTOELECTRIC SMOKE DETECTOR
with INTERCONNECT and TIMER****AC ELECTRICAL CHARACTERISTICS, continued.**

Characteristic	Symbol	Test Conditions	Test Pin	V _{DD}	Limits			Units
					Min.	Typ.	Max.	
Strobe Pulse Period	t _{st1}	No Local or Remote Smoke	4	9	9.6	–	11.9	s
	t _{st2}	After 1 of 3 Valid Samples	4	9	2.42	2.70	2.96	s
	t _{st3}	After 2 of 3 Valid Samples and During Local Alarm	4	9	1.21	1.34	1.47	s
	t _{st4}	Remote Alarm	4	9	9.67	10.8	11.8	s
	t _{st5}	Chamber Test or Low Supply Test, No Local Alarm	4	9	38.9	–	47.1	s
	t _{st6}	Pushbutton Test, No Alarm	4	9	300	336	370	ms
Strobe Pulse Width	t _{w(st)}		4	9	9.5	–	11.5	ms
I _{RED} Pulse Period	t _{ired1}	No Local or Remote Smoke	6	9	9.6	–	11.9	s
	t _{ired2}	After 1 of 3 Valid Samples	6	9	2.42	2.70	2.96	s
	t _{ired3}	After 2 of 3 Valid Samples and During Local Alarm	6	9	1.21	1.34	1.47	s
	t _{ired4}	Remote Alarm	6	9	9.67	10.8	11.8	s
	t _{ired5}	Chamber Test, No Local Alarm	6	9	38.9	–	47.1	s
	t _{ired6}	Pushbutton Test, No Alarm	6	9	300	336	370	ms
I _{RED} Pulse Width	t _{w(ired)}		6	9	94	–	116	μs
I _{RED} Rise Time	t _{r(ired)}	10% to 90%	6		–	–	30	μs
I _{RED} Fall Time	t _{f(ired)}	90% to 10%	6		–	–	200	μs
I/O to Active Delay	t _{d(io)}	Local Alarm	7	9	–	0	–	s
Rising Edge on I/O to Alarm	t _{r(io)}	No Local Alarm	7	9	–	–	1.34	s
Horn Warning Pulse Period	t _{horn}	Low Supply and Degraded Chamber Sensitivity	8, 9	9	38.9	–	47.1	s
Horn Warning Pulse Width	t _{w(horn)}	Low Supply and Degraded Chamber Sensitivity	8, 9	9	9.5	–	11.5	ms
Horn ON Time	t _{on(horn)}	Local or Remote Alarm	8, 9	9	–	252	–	ms
Horn OFF Time	t _{off(horn)}	Local or Remote Alarm	8, 9	9	–	84	–	ms

* Limits over the operating temperature range are based on characterization data.

Characteristics are production tested at +25°C only.

Typical values are at +25°C and are given for circuit design information only.

5358

PHOTOELECTRIC SMOKE DETECTOR
with INTERCONNECT and TIMER

PIN AND CIRCUIT DESCRIPTION
(In Typical Application)

PIN 1 (C₁)

A capacitor connected to this pin determines the gain of the photo amplifier during the push-to-test mode and during the chamber monitor test. A typical value for this high-gain mode is 0.047 μ F but should be selected based on the photo chamber background reflections reaching the detector and the desired level of sensitivity.

$A_e \approx 1+(C_1/10)$ where C_1 is in pF. A_e should not exceed 10 000.

PIN 2 (C₂)

A capacitor connected to this pin determines the gain of the photo amplifier during standby. A typical value for this low-gain mode is 4700 pF but should be selected based on a specific photo chamber and the desired level of sensitivity to smoke. $A_e \approx 1+(C_2/10)$ where C_2 is in pF. A_e should not exceed 10 000. This gain increases by a nominal 10% after a local alarm is detected (three consecutive detections). **Coupling of other signals to C₂ (C₁ and the DETECT inputs also) must be minimized.**

A resistor must be installed in series with C₂.

PIN 3 (DETECT)

This is the input to the photo amplifier and is connected to the cathode of the photo diode. The photo diode is operated at zero bias and should have low dark-leakage current and low capacitance.

PIN 4 (STROBE)

This output provides a strobed, regulated voltage of $V_{DD} - 5$ V. The minus side of all internal and external photo amplifier circuitry is referenced to this pin.

PIN 5 (V_{DD})

This pin is connected to the most-positive supply potential and can range from 6 V to 12 V with respect to V_{SS} .

PIN 6 (I_{RED})

This output provides a pulsed base current for the external npn transistor, which drives the IR emitter. Its beta should be greater than 100. The I_{RED} output is not active, to minimize noise impact, when the horn and visible LED outputs are active.

PIN 7 (I/O)

A connection at this pin allows multiple smoke detectors to be interconnected. If a local smoke condition occurs, this pin is driven high. As an input, this pin is sampled nominally every 1.35 seconds during standby. Any local-alarm condition causes this pin to be ignored as an input.

This pin has an on-chip pull-down resistor and must be left unconnected if not used. In application, there is a series current-limiting resistor to other smoke alarms.

PIN 8 (HORN₁)

PIN 9 (HORN₂)

PIN 10 (FEEDBACK)

These three pins are used in conjunction with external passive components and a self-resonating piezoelectric transducer. HORN₁ is connected to the piezo metal support electrode; the complementary output, HORN₂, is connected to the ceramic electrode and the FEEDBACK input to the feedback electrode.

A continuous modulated tone indicates either a local or remote alarm condition. A short (10 ms) chirp indicates a low-battery condition or degraded chamber sensitivity. The low-battery chirp occurs almost simultaneous with the visible LED flash. If the FEEDBACK pin is not used, it must be connected to V_{DD} or V_{SS} .

Continued...

5358

PHOTOELECTRIC SMOKE DETECTOR with INTERCONNECT and TIMER

PIN AND CIRCUIT DESCRIPTION, continued

PIN 11 (LED)

This open-drain NMOS output is used to directly drive a visible LED. The load for the low-battery test is applied to this output. The low-battery test does not occur coincident with any other test or alarm signal. The LED also indicates detector status as follows (with component values as in the typical application, all times nominal):

- Standby** - Pulses every 43 seconds.
- Local Smoke** - Pulses every 0.67 second.
- Remote Alarm** - No pulses.
- Test Mode** - Pulses every 0.67 second.
- Timer Mode** - Pulses every 10 seconds.

PIN 12 (OSC. CAP.)

A capacitor between this pin and V_{DD} , along with a parallel resistor, forms part of a two-terminal oscillator and sets the internal clock low time. With component values as shown, this nominal time is 11 ms and essentially the oscillator period.

PIN 13 (TIMING RES.)

A resistor between this pin and OSC. CAP. (pin 12) is part of the two-terminal oscillator and sets the internal clock high time, which is also the I_{RED} pulse width. With component values as shown, this nominal time is 105 μ s.

PIN 14 (V_{SS})

This pin is connected to the most negative supply potential (usually ground).

PIN 15 (HUSH)

This input pin serves two purposes in normal operation. It serves as an enable for the internal 10-minute (nominal) timer and also as the reference for the smoke comparator during the timer mode. This reference is established by a resistive divider between V_{DD} and STROBE (R_{X1} and R_{X2}). This allows the detector to have a different sensitivity set point during the timer mode. If the timer mode is not used, this pin can be left open or connected to V_{SS} , which disables this mode.

PIN 16 (TEST)

This pin has an internal pull-down device and is used to manually invoke two test modes and a Timer Mode.

The Push-to-Test Mode is initiated by a high logic level on this pin (usually the depression of a normally open push-button switch to V_{DD}). After one oscillator

cycle, I_{RED} pulses every 336 ms (nominal) and amplifier gain is increased by internal selection of C_1 . Background reflections in the smoke chamber can be used to simulate a smoke condition. After the third I_{RED} pulse, a successful test (three consecutive simulated smoke conditions) activates the horn drivers and the I/O pin. When the push-button is released, the input returns to V_{SS} due to the internal pull down. After one oscillator cycle, the amplifier gain returns to normal and after three additional I_{RED} pulses (less than one second), the device exits this mode and returns to standby. This high-to-low transition on pin 16 also resets and starts the 10 minute hush timer (timer mode).

Pin Name	Pin No.	Configuration
I/O	7	Disabled as an output. A logic high on this pin places the photo amplifier output on pin 1 or pin 2 as determined by pin 15. The amplifier output appears as pulses.
HUSH	15	If the I/O pin is high, this pin controls the amplifier gain capacitor. If pin 15 is low, normal gain is selected and the amplifier output is on pin 1. If pin 15 is high, supervisory gain is selected and the amplifier output is on pin 2.
FEEDBACK	10	If pin 7 is high and pin 15 is low (normal gain), taking this pin to a high logic level increases the amplifier gain by ~10% (hysteresis).
OSC. CAP.	12	This pin may be driven by an external clock source. Driving this pin low and high drives the internal clock low and high. The external RC network may remain intact.

5358 PHOTOELECTRIC SMOKE DETECTOR with INTERCONNECT and TIMER

PIN AND CIRCUIT DESCRIPTION, continued

The Diagnostic Test Mode is initiated by pulling this pin below V_{SS} and continuously sourcing $400\ \mu\text{A}$ from the pin for at least one clock cycle on the OSC. CAP. pin. This mode is used to facilitate calibration and test of the IC and the assembled detector. In this mode, certain device pins are reconfigured as described below. In this mode, the I_{RED} pulse rate is increased to one every OSC. CAP. cycle and the STROBE pin is always active. To exit this mode, the test pin is floated for at least one OSC. CAP. cycle.

Pin Name	Pin No.	Configuration
HORN ₁	8	This pin is reconfigured as the smoke integrator output. Three consecutive smoke detections will cause this pin to go high and three consecutive no-smoke detections cause this pin to go low.
LED	11	This pin becomes a low-battery indicator. The open-drain NMOS output is normally OFF. If V_{DD} falls below the low-battery threshold, the output turns ON.

TYPICAL APPLICATION

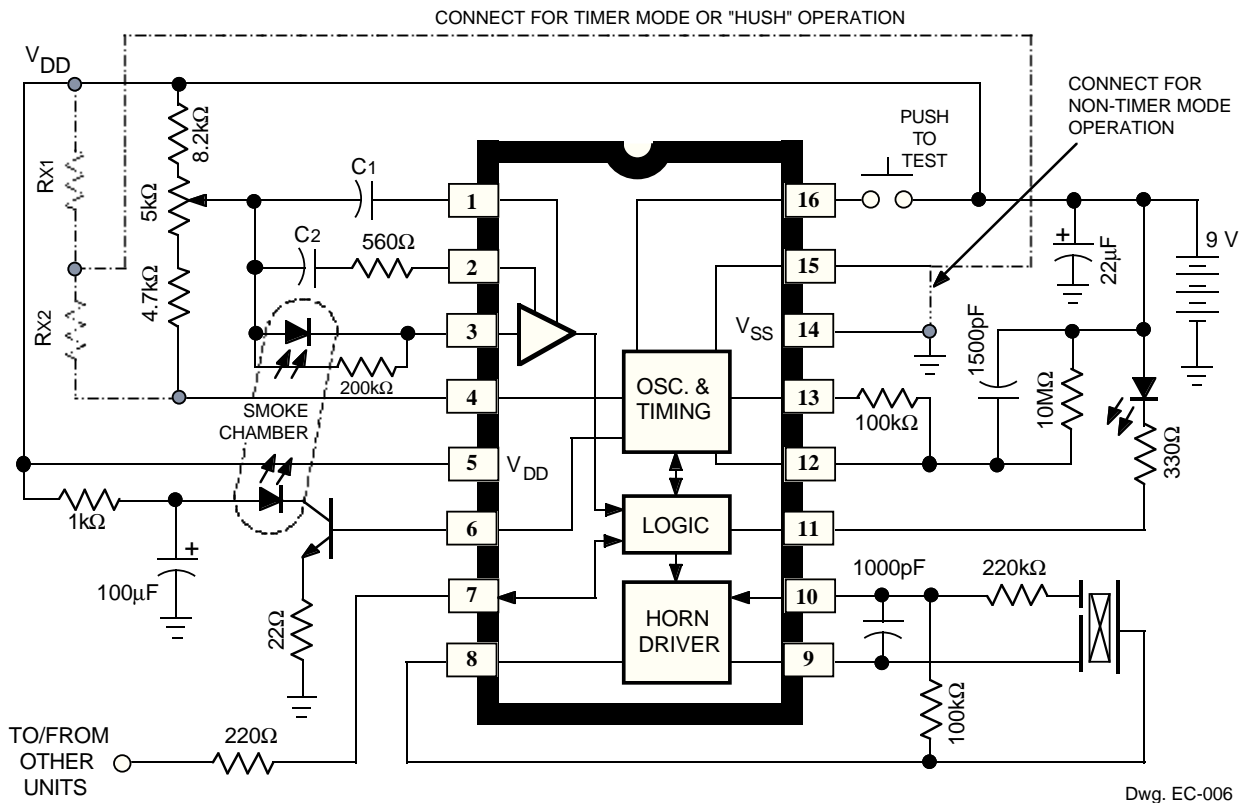

5358
PHOTOELECTRIC SMOKE DETECTOR
with INTERCONNECT and TIMER

STANDBY TIMING DIAGRAM
(not to scale)

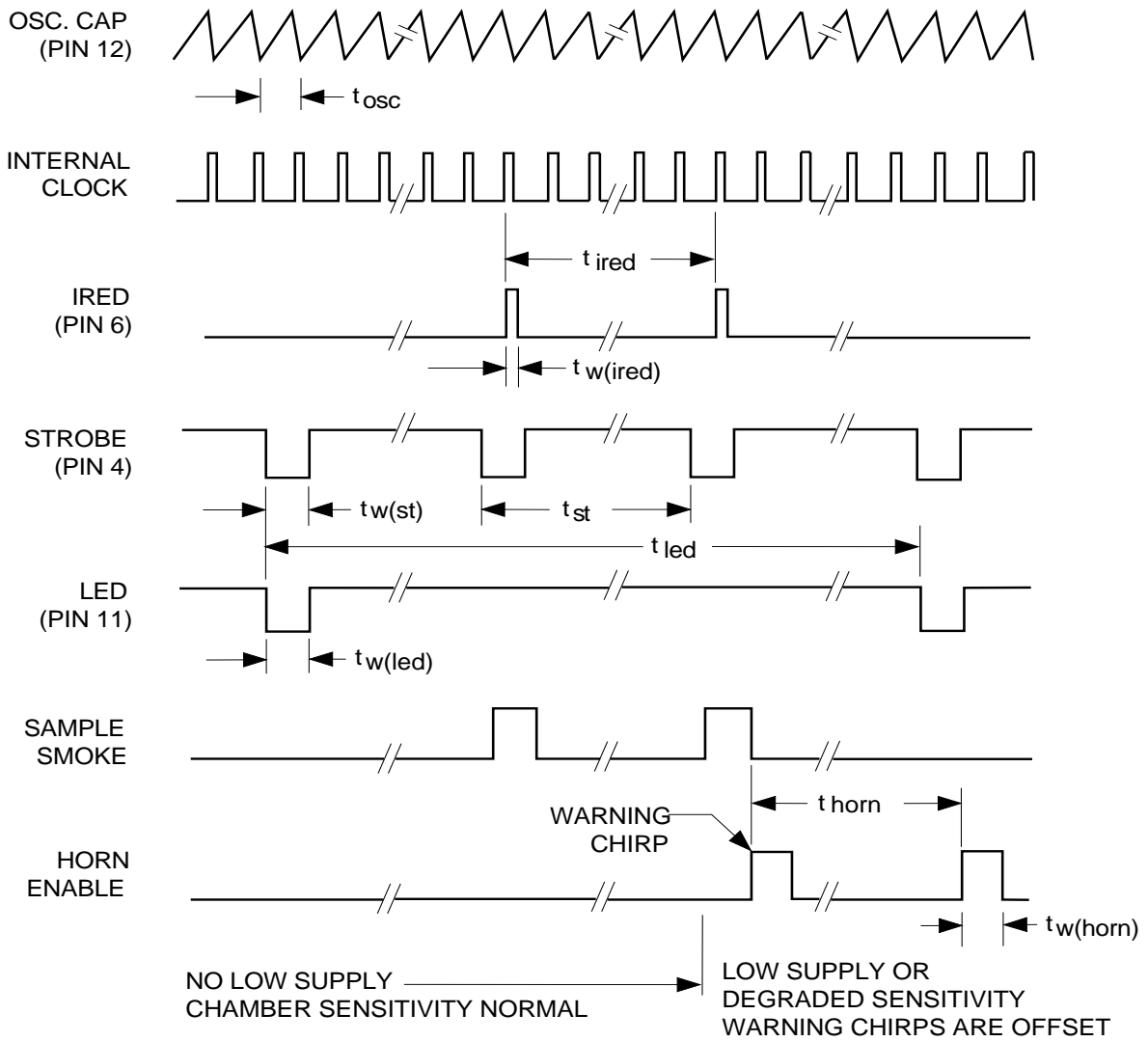

5358
PHOTOELECTRIC SMOKE DETECTOR
with INTERCONNECT and TIMER

LOCAL ALARM TIMING DIAGRAM
(not to scale)

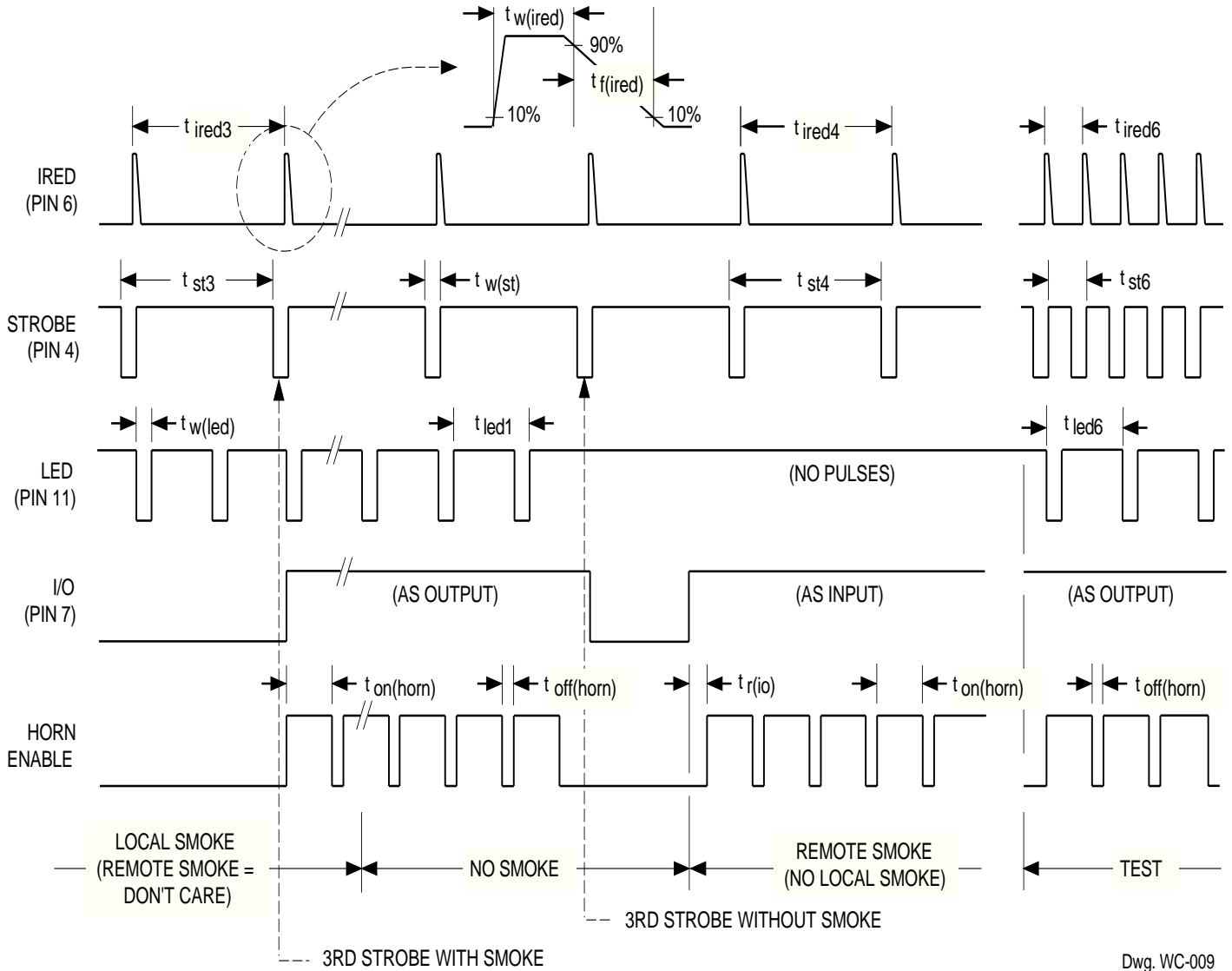

Dwg. WC-009

5358
PHOTOELECTRIC SMOKE DETECTOR
with INTERCONNECT and TIMER

Dimensions in Inches
(controlling dimensions)

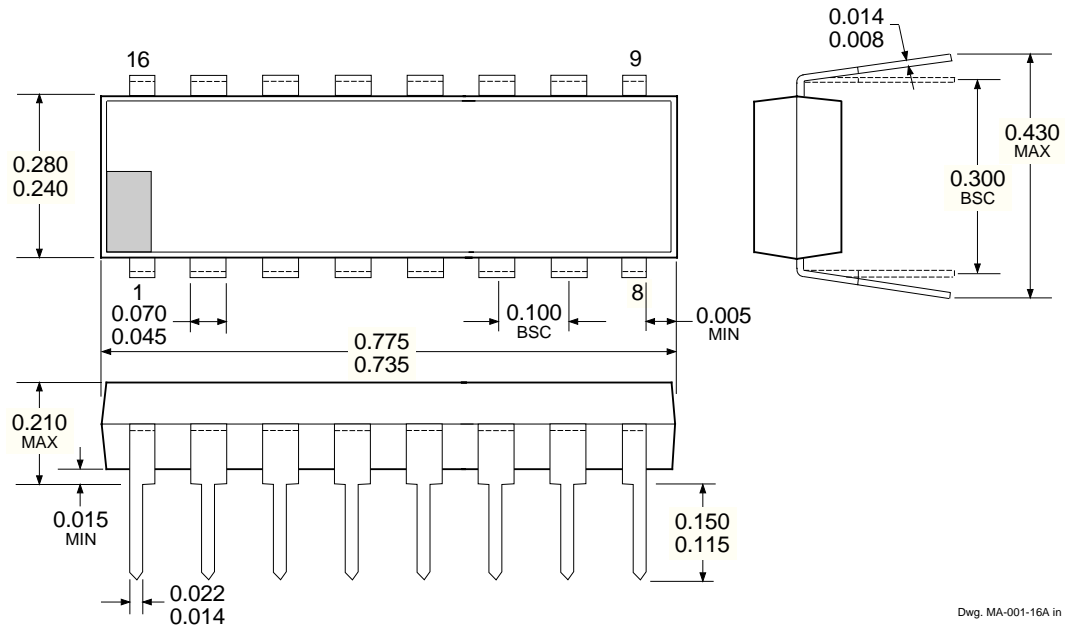

Dwg. MA-001-16A in

Dimensions in Millimeters
(for reference only)

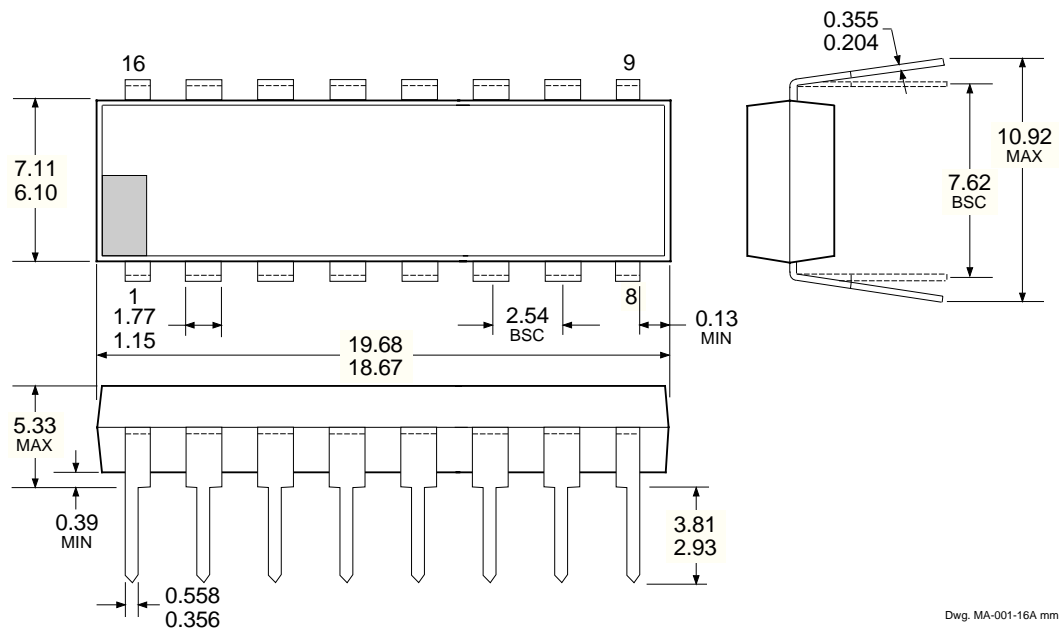

Dwg. MA-001-16A mm

- NOTES:
1. Lead thickness is measured at seating plane or below.
 2. Lead spacing tolerance is non-cumulative.
 3. Exact body and lead configuration at vendor's option within limits shown.

5358
PHOTOELECTRIC SMOKE DETECTOR
with INTERCONNECT and TIMER

SAFETY & SECURITY ICs
SELECTION GUIDE

Part Number	Function
A3054KU/SU	Multiplexed Two-Wire Hall-Effect Sensor
A5347CA	Ionization-Type Smoke Detector with Interconnect and Timer
A5348CA	Ionization-Type Smoke Detector with Interconnect, Timer, and Reverse-Battery Protection
A5349CA	Ionization-Type Smoke Detector with Interconnect and Timer for AC Line Operation
A5350CA	Ionization-Type Smoke Detector with Interconnect and Reverse-Battery Protection
A5358CA	Photoelectric-Type Smoke Detector with Interconnect and Timer

Allegro MicroSystems, Inc. reserves the right to make, from time to time, such departures from the detail specifications as may be required to permit improvements in the design of its products. The information included herein is believed to be accurate and reliable. However, Allegro MicroSystems, Inc. assumes no responsibility for its use; nor for any infringements of patents or other rights of third parties which may result from its use.



115 Northeast Cutoff, Box 15036
Worcester, Massachusetts 01615-0036 (508) 853-5000