



ILC DATA DEVICE CORPORATION

ILC DATA DEVICE CORP 60 DE 4678769 0004141 3

IDC-14542 AND IDC-14544

T-71-35-03

SPECIFICATIONS			
Apply over temperature range, power supply range, reference frequency and amplitude range, $\pm 10\%$ signal amplitude variation, and up to 10% harmonic distortion in the reference.			
PARAMETER.	UNITS	VALUE	
		IDC-14542	IDC-14544
CONVERTER		12	14
RESOLUTION	bits	12	14
ACCURACY	min	± 8.5	± 5.3
DYNAMIC CHARACTERISTICS			
Input Rate	rp/s	100	25
Acceleration Constant		$K_a = 460,000$	$K_a = 370,000$
Settling Time (179° step to 1 LSB)	ms	60	90
Velocity Constant		$K_v = \infty$ (No limitation with type II servo loop)	
REFERENCE INPUT			
Carrier Frequency	Hz	360 to 22k	600 to 11k
Voltage Range	V_{rms}	4 to 50 (26 nom)	
Input Impedance			
Single Ended	Ω	50k min	
Differential	Ω	100k min	
Common Mode Range (DC Common mode plus recurrent AC peak)	V	60 max	
SIGNAL INPUT CHARACTERISTICS			
Input Signal Type		Sin and cos resolver signals referenced to internal DC reference V	
Voltage Level	V	2 nom, 2.3 max	
Maximum voltage without damage	V	15 rms continuous; 100 peak transient	
Input Impedance	Ω	Z_{in} 20M (transient protected voltage follower)	
DIGITAL INPUT/OUTPUT			
Logic		TTL/CMOS compatible, depending on logic supply voltage	
Inputs		Logic "0" inhibits	
Inhibit (INH)		\overline{ENM} and \overline{ENL} [logic "0" Enables	
Enable Bits 1-6 \overline{ENM}		logic "1" high impedance	
Enable Bits 7-12 \overline{ENL}			
Enable Bits 7-14 \overline{ENL}			
OUTPUTS			
Parallel Data	bits	12 or 14 parallel lines, natural binary angle, positive logic	
Count (CB)		0.7 to 2.0 μ sec positive pulse; leading edge initiates counter update	
Drive Capability	TTL TTL μA	1 std load, 1.6 mA at 0.4 V max (logic "0") 10 std loads, 0.4 mA at 2.8 V min (logic "1") 10 max (high impedance)	
ANALOG OUTPUTS			
Internal DC Reference (V)		+15 VDC/2 ~ 7V nom	
AC Error (e)		10 mV rms per LSB of error (14 bits) 12.5 mV rms per LSB of error (12 bits)	
Filtered DC Error Voltage (E)		-1 VDC per +LSB of error (± 3 LSB range), 14 bits -1.25 VDC per +LSB of error (± 3 LSB range), 12 bits	
POWER SUPPLY CHARACTERISTICS			
Nominal Voltage	V	+15V Supply	Logic Supply
Voltage Range	V	+11 to +16.5	+4.5 to +15
Maximum Voltage Without Damage	V	+18	+18
Current or Impedance		25 mA max	$Z_{in} = 5k\Omega$ min
TEMPERATURE RANGES			
Operating		0 to +70	
-3XX	$^{\circ}C$	-55 to +125	
-1XX	$^{\circ}C$	-55 to +135	
Storage	$^{\circ}C$		
PHYSICAL CHARACTERISTICS			
Package		36 pin DDIP	
Size	in	0.78 x 1.9 x 0.21 (19.7 x 48 x 5.3 mm)	
Weight	oz	1.0 (28 gm)	





IDC-14542 AND IDC-14544

ILC DATA DEVICE CORPORATION

T-71-35-03

TECHNICAL INFORMATION

DIRECT INPUT

The input of the IDC-14542 and IDC-14544 requires that an external signal conditioner be provided to establish a 2.0 V rms input signal referenced to the converter's internal DC reference (V). Figure 4 suggests a method for amplifying the output of an Inductosyn to meet the required signal input level. The use of this circuit will sufficiently condition the input so resistors R3 and R4 are not needed for most applications.

Trimming should be done by measuring the differential voltage at the input of the op amp closest to the Inductosyn slider (+sin). The output voltage is then measured to determine the gain. The same procedure is performed on the +cos amplifier. A high accuracy digital voltmeter is recommended for the final output readings. Capacitors C1 and C2 are used to create a DC voltage block.

LOGIC INPUT/OUTPUT

Logic outputs consist of 12 or 14 parallel data bits and count (CB). All logic outputs are short-circuit proof to ground and to positive voltages as high as V_L . The CB output is a positive 0.7-2.0 μ s pulse and data changes about 0.2 μ s after the leading edge of the pulse, because of an internal delay (figure 1). Data is valid 0.5 μ s after the leading edge of a CB. Angle is determined by adding bits in the "1" state.

The parallel digital outputs are gated to provide 6 or 8 bit bytes when the MSB byte is enabled (\overline{ENM}). The 8 bit byte is reserved for the 14 bit resolution converter only. The LSB byte (\overline{ENL}) is gated to provide a 6 bit byte. When the Enables for the gates are at logic "0" the gate outputs are at normal logic "1" or "0", depending on the bit state. When the Enables are at logic "1" the gate outputs are high impedance and the subsystem sees an essentially open line. Outputs are valid 0.5 μ s after an Enable is driven to logic "0". For 12 and 14 bit parallel output operation, when the 3-state feature is not used, the Enable lines should be tied to logic "0".

The Inhibit (INH) logic input locks the transparent latch so that the bits will remain stable while data is being transferred (see Figure 1). The output is stable 0.5 μ s after the Inhibit is driven to logic "0". A logic "0" at the T input locks the latch, and a logic "1" allows the bits to change. The purpose of the INH transparent latch is to prevent the transmission of invalid data when there is an overlap between the CB and INH. While the counter is not being updated the CB is at logic "0" and the INH latch is transparent. When the CB goes to logic "1" the INH latch is locked. If a CB occurs after an INH has been applied, the latch will remain locked and its data cannot change until the CB returns to logic "0". If an INH is applied during a CB pulse, the latch will not lock until the CB pulse is over. The purpose of the 0.2 μ s delay is to prevent a race condition between the CB and the INH in which the up-down counter begins to change just as an INH is applied.

Since the IDC-14542 and IDC-14544 converters contain a CMOS device, standard CMOS handling procedures should be followed.

TIMING

Figure 2 shows the timing waveforms of the converter. Whenever an input angle change occurs, the converter changes the digital angle in 1 LSB steps and generates a converter busy pulse. The output data change is initiated by the leading edge of the CB pulse, delayed by the 0.2 μ s (nominal) delay. The output becomes stable in less than 0.5 μ s even though the CB pulse may last longer. Data transfer can be made synchronous with the leading edge of CB, delayed by 0.5 μ s. (See Timing Diagram.)

An Inhibit input, regardless of its duration, does not affect converter update. A simple method of interfacing to a computer, asynchronous to CB pulse, is to (a) apply the inhibit, (b) wait 1.5 μ s min., (c) transfer the data and (d) release the inhibit.

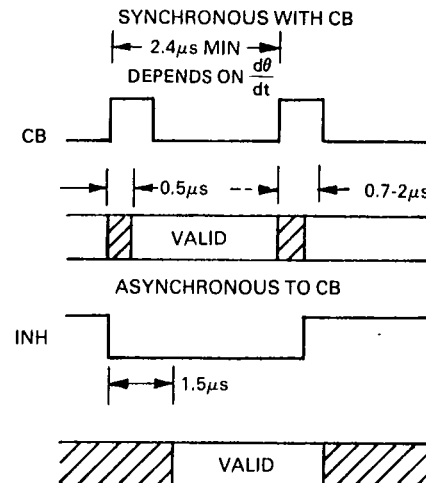
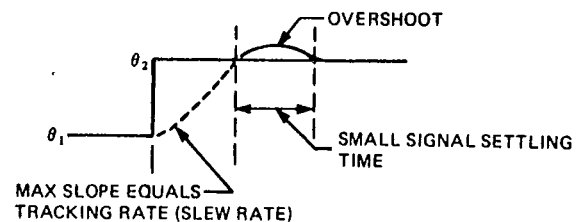

FIGURE 2. TIMING DIAGRAM

DYNAMIC PERFORMANCE

A Type II servo loop ($K_V = \infty$) and very high acceleration constants give these converters superior dynamic performance, as listed in the specifications. If the power supply voltage is not the +15VDC nominal value, the specified input rates for full accuracy will increase or decrease in proportion to the fractional change in voltage.

As long as the maximum tracking rate is not exceeded, there will be no lag in the converter output. If a step input occurs, as is likely when the power is initially turned on, the response will be critically damped. The figure shows the response to a step input. After initial slewing at the maximum tracking rate of the converter, there is one overshoot which is inherent to a Type II servo. The overshoot settling to a final value is a function of the small signal settling time.



RESPONSE TO A STEP INPUT



ILC DATA DEVICE CORPORATION

4678769 I L C DATA DEVICE CORP

I L C DATA DEVICE CORP 60 DE 4678769 0004143 7

IDC-14542 AND IDC-14544

82D 04143DT-71-35-03

ANALOG OUTPUTS

The analog outputs are V, e, E and VEL. V is an internal DC reference, ±7 VDC nominal. The outputs e, E and VEL ride on the internal DC reference voltage V, and should be measured with respect to V. Outputs can swing ±5V when the voltage level of the +15V power supply is +15V. The output swing changes proportionally if the level is not a +15V.

AC error (e) is proportional to the error (θ-φ) with 10 mV/LSB nominal for the 14 bit unit and 12.5 mV/LSB nominal for the 12 bit units.

E is a filtered DC voltage proportional to the error (θ-φ) near the null point, with -1 VDC/+LSB of error for the 14 bit unit and -1.25 VDC/+LSB of error for the 12 bit units.

Velocity output (VEL) is a DC voltage proportional to angular velocity dθ/dt=dφ/dt. The output is positive for an increasing angle.

Maximum loading for each analog output is 1.0 mA. Outputs e, E, and VEL are not required for normal operation of the converter; V is used as internal DC reference.

The outputs e, E and VEL are not closely controlled or characterized. Consult factory for further information.

$$G = \frac{680^2 \left(\frac{S}{300} + 1 \right)}{S^2 \left(\frac{S}{3000} + 1 \right)} \quad G = \frac{610^2 \left(\frac{S}{300} + 1 \right)}{S^2 \left(\frac{S}{3000} + 1 \right)}$$

12 BIT

14 BIT

CONVERTER LOOP DYNAMICS

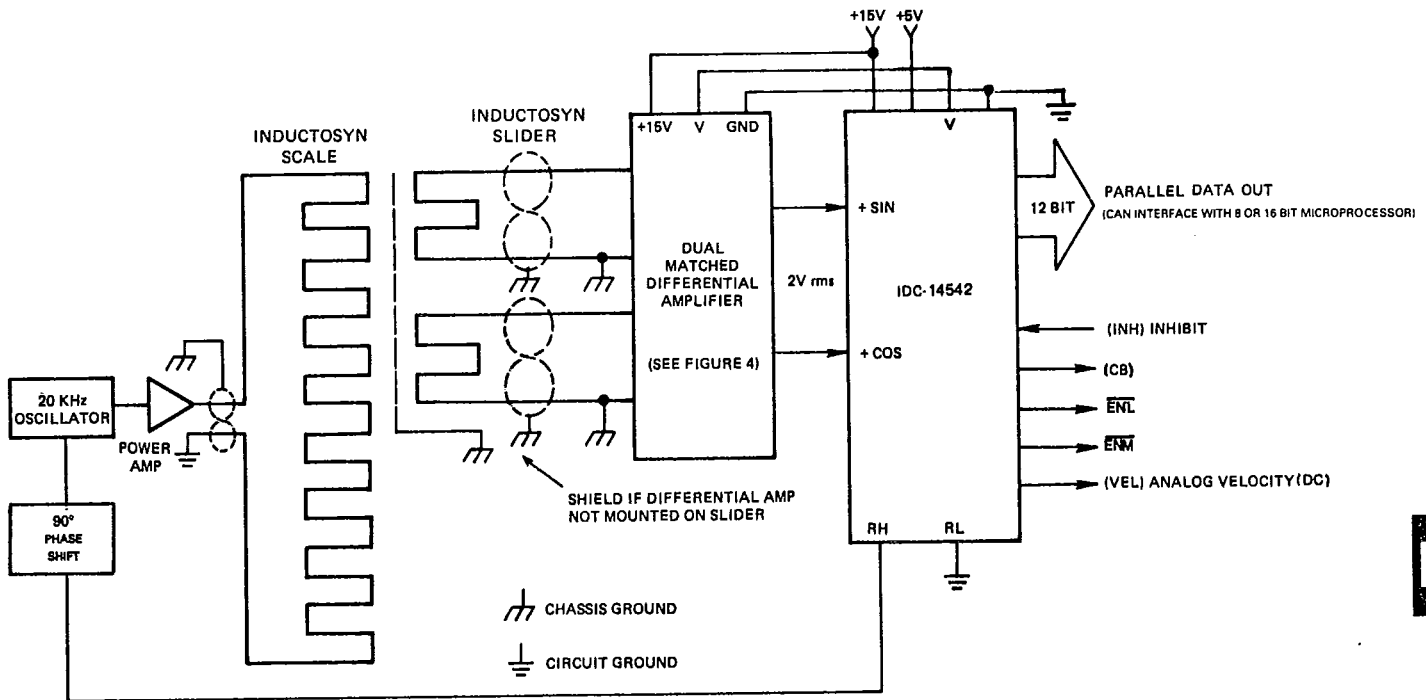
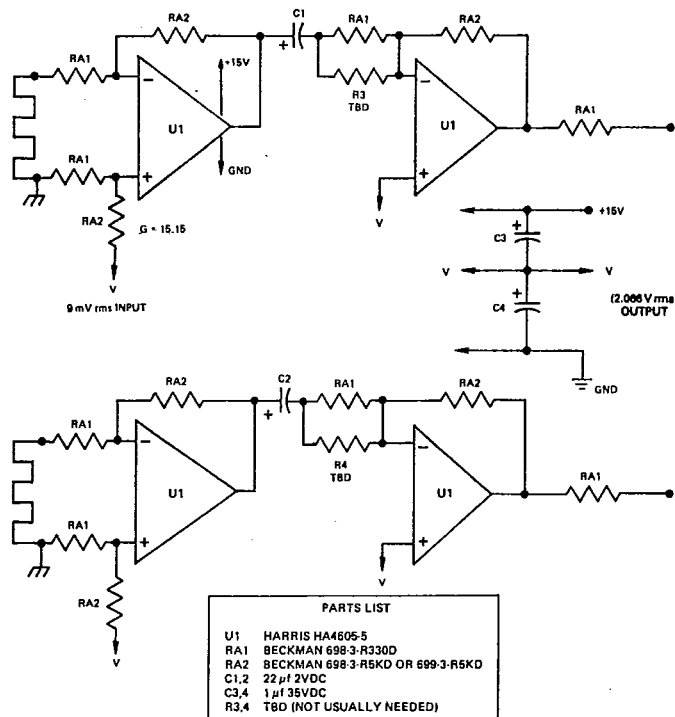

FIGURE 3. INDUCTOSYN CONNECTION DIAGRAM

IDC-14542 AND IDC-14544

ILC DATA DEVICE CORPORATION

T-71-35-03



PARTS LIST	
U1	HARRIS HA4605-5
RA1	BECKMAN 698-3-R330D
RA2	BECKMAN 698-3-R5KD OR 699-3-R5KD
C1,2	22µf 2VDC
C3,4	1µf 35VDC
R3,4	T8D (NOT USUALLY NEEDED)

NOTES: 1. For other input levels select RA1 and RA2 as required. Standard values are: 100, 200, 330, 470, 500, 1K, 2K, 2.2K, 4.7K, 5K, 10K, 15K, and 20KΩ.
2. For lower input levels use Harris HA-4625-5

FIGURE 4. DUAL PREAMPLIFIER DIAGRAM

PIN CONNECTION TABLE

PIN	FUNCTION	PIN	FUNCTION
	Voltage Follower Buffer	18	Bit 14
1	NC	19	RH (Ref High)
2	COS	20	RL (Ref Low)
3	SIN	21	N.C.
4	NC	22	E (Filtered DC Error Out)
5	Bit 1 MSB	23	θ (Analog Velocity Out)
6	Bit 2	24	CB (Converter Busy)
7	Bit 3	25	ENL (Enable, Bits 7 to 14)*
8	Bit 4	26	ENM (Enable, Bits 1 to 6)
9	Bit 5	27	e (AC Error Out)
10	Bit 6	28	V _L (Logic Voltage Input)
11	Bit 7	29	GND
12	Bit 8	30	T.P.
13	Bit 9	31	N.C.
14	Bit 10	32	+15V (Power Supply In)
15	Bit 11	33	INH (Inhibit)
16	Bit 12	34	V (Internal DC Ref)
17	Bit 13	35	BC (Buffered Cos)
		36	BS (Buffered Sin)

NOTES:
BS and BC pins are used in other applications.
*Enable 7 to 12 (IDC-14542)

IN GENERAL

For applications where a square wave is more convenient than the conventional sine wave, the IDC-14542 and IDC-14544 are capable of operating with square waves.

For users who desire a built-in test (BIT) function to detect position error between the input and output, a simple detection circuit can be implemented with the AC error signal provided by the IDC-14542 and IDC-14544 converter. The schematic diagram for the BIT circuit is available from DDC.

C-4/86

RELIABILITY

MTBF values are very high because the use of custom monolithics greatly decreases the number of active components, because thin film resistor networks are used, and because of careful thermal design. Summaries of MTBF calculations are available on request.

All DDC hybrids are built in accordance with requirements of MIL-STD-883B.

MECHANICAL OUTLINE 36 PIN DOUBLE DIP

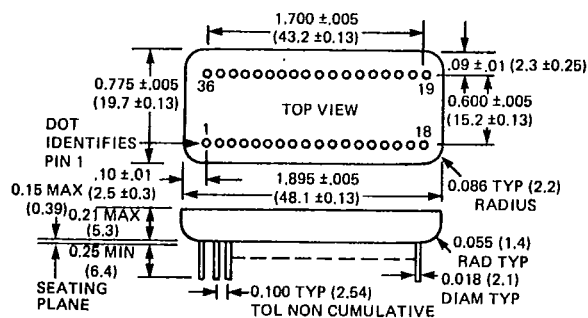

NOTES

- Dimensions shown are in inches. (millimeters)
- Lead identification numbers are for millimeters.
- Lead cluster shall be centered within ±0.10 of outline dimensions. Lead spacing dimensions apply only at seating plane.
- Pin material meets solderability requirements of MIL-STD-202E, Method 208C.
- Package is Kovar with electroless nickel plating.
- Case is electrically floating.

ORDERING INFORMATION

IDC-1454 X-X X X

