



# Quad DPDT Audio/Data Switches in UCSP/QFN

MAX4758/MAX4759

## General Description

The MAX4758/MAX4759 quad double-pole/double-throw (DPDT) analog switches operate from a single +1.8V to +5.5V supply. These switches feature low 0.5Ω on-resistance for audio switching and a low 25pF capacitance for data switching.

The MAX4758 has eight 0.5Ω on-resistance switches to switch audio signals. The MAX4759 has four 0.5Ω on-resistance switches to route audio signals and four 25pF capacitance switches to route data signals. The MAX4758/MAX4759 have four logic inputs to control the switches in pairs.

The MAX4758/MAX4759 are available in a small 36-pin (6mm x 6mm) thin QFN and 36-bump (3mm x 3mm) chip-scale package (UCSP™).

## Applications

- |                           |                         |
|---------------------------|-------------------------|
| Speaker-Headset Switching | PDA's/Hand-Held Devices |
| Audio-Signal Routing      | Notebook Computers      |
| Cellular Phones           | USB Signal Switching    |

## Features

- ◆ Data and Audio Signal Routing
- ◆ Low On-Resistance (0.5Ω) Audio Switches
- ◆ 0.2Ω On-Resistance Flatness
- ◆ 0.1Ω Channel-to-Channel Matching
- ◆ Low-Capacitance (25pF) Data Switches (MAX4759)
- ◆ 0.2ns Skew (MAX4759)
- ◆ 0.03% THD
- ◆ +1.8V to +5.5V Supply Range
- ◆ Rail-to-Rail Signal Handling
- ◆ Tiny 36-Bump UCSP (3mm x 3mm)
- ◆ 36-Pin Thin QFN (6mm x 6mm)

## Ordering Information

PART	TEMP RANGE	PIN-PACKAGE
MAX4758EBX-T	-40°C to +85°C	36 UCSP-36
MAX4758ETX	-40°C to +85°C	36 Thin QFN (6mm x 6mm)
MAX4759EBX-T	-40°C to +85°C	36 UCSP-36
MAX4759ETX	-40°C to +85°C	36 Thin QFN (6mm x 6mm)

## Functional Diagrams

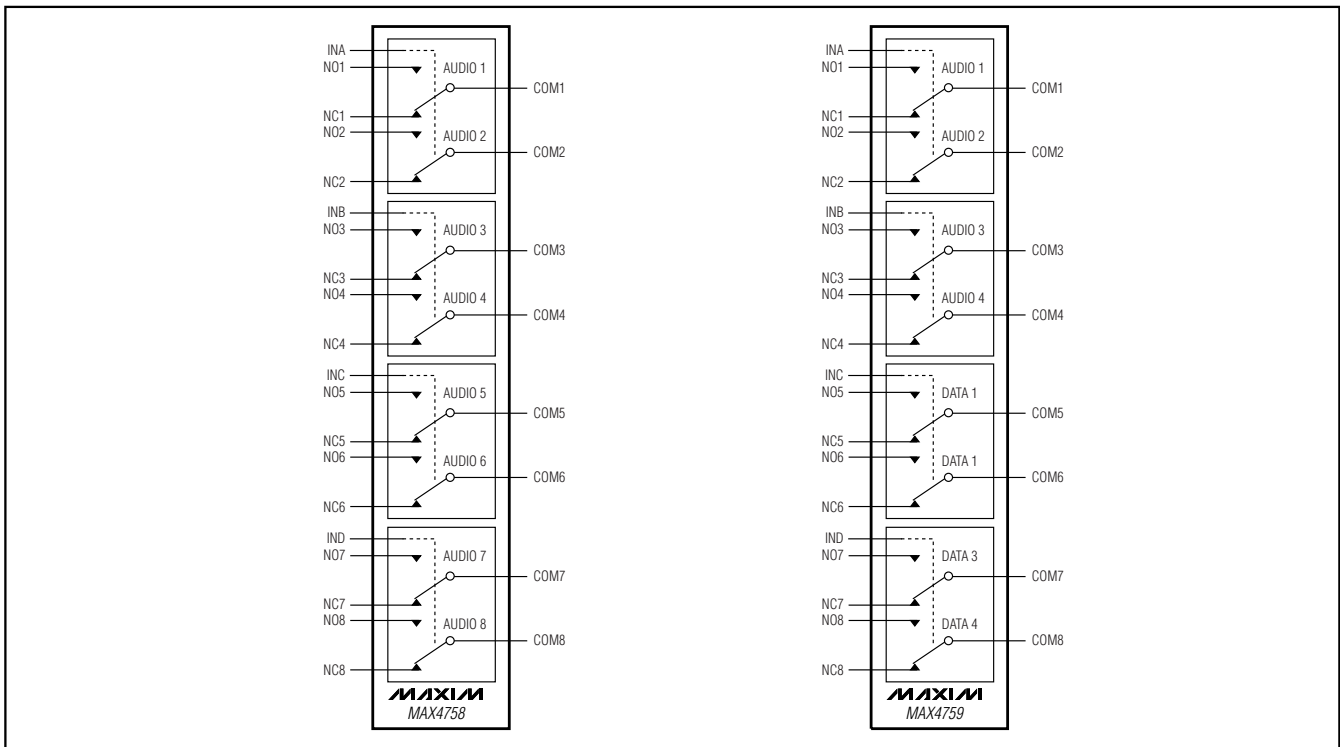

UCSP is a trademark of Maxim Integrated Products, Inc.

Pin Configurations/Truth Table appear at end of data sheet.



For pricing, delivery, and ordering information, please contact Maxim/Dallas Direct! at 1-888-629-4642, or visit Maxim's website at [www.maxim-ic.com](http://www.maxim-ic.com).

# Quad DPDT Audio/Data Switches in UCSP/QFN

## ABSOLUTE MAXIMUM RATINGS

(All voltages referenced to GND.)

V+, IN_	-0.3V to +6V
COM_, NO_, NC_ (Note 1)	-0.3V to (V+ + 0.3V)
Continuous Current	
NO_, NC_, COM_ (MAX4758)	±300mA
NO1–NO4, NC1–NC4, COM1–COM4 (MAX4759)	±300mA
NO5–NO8, NC5–NC8, COM5–COM8 (MAX4759)	±100mA
Peak Current NO_, NC_, COM_ (MAX4758)	
NO1–NO4, NC1–NC4, COM1–COM4 (MAX4759)	(pulsed at 1ms, 10% duty cycle) ±500mA
	(pulsed at 1ms, 50% duty cycle) ±400mA
Peak Current NO5–NO8, NC5–NC8, COM5–COM8 (MAX4759)	
	(pulsed at 1ms, 10% duty cycle) ±200mA
	(pulsed at 1ms, 50% duty cycle) ±300mA

Continuous Power Dissipation (T<sub>A</sub> = +70°C)

36-Bump UCSP (derate 15.3mW/°C above +70°C)	1221mW
36-Pin Thin QFN (derate 26.3mW/°C above +70°C)	2105mW
ESD per Method 3015.7	±2kV
Operating Temperature Range	-40°C to +85°C
Junction Temperature	+150°C
Storage Temperature Range	-65°C to +150°C
Lead Temperature (soldering, 10s)	+300°C
Bump Temperature (soldering)	
Infrared (15s)	+220°C
Vapor Phase (60s)	+215°C

**Note 1:** Signals on NO\_, NC\_, COM\_ exceeding V+ or GND are clamped by internal diodes. Limit forward-diode current to maximum current rating.

Stresses beyond those listed under "Absolute Maximum Ratings" may cause permanent damage to the device. These are stress ratings only, and functional operation of the device at these or any other conditions beyond those indicated in the operational sections of the specifications is not implied. Exposure to absolute maximum rating conditions for extended periods may affect device reliability.

## ELECTRICAL CHARACTERISTICS

(V+ = +2.7V to +5.25V, T<sub>A</sub> = -40°C to +85°C, unless otherwise noted. Typical values are at V+ = 3V, T<sub>A</sub> = +25°C.) (Notes 2, 3)

PARAMETER	SYMBOL	CONDITIONS	T <sub>A</sub>	MIN	TYP	MAX	UNITS
<b>ANALOG SWITCH</b>							
Analog Signal Range	V <sub>COM_</sub> , V <sub>NO_</sub> , V <sub>NC_</sub>		T <sub>MIN</sub> to T <sub>MAX</sub>	0		V+	V
On-Resistance (Note 4)	R <sub>ON</sub>	V+ = 2.7V, I <sub>COM_</sub> = 10mA, V <sub>NC_</sub> or V <sub>NO_</sub> = 0 or V+	MAX4758, MAX4759 (N_1–N_4)	+25°C	0.5	0.85	Ω
			T <sub>MIN</sub> to T <sub>MAX</sub>			1.0	
		MAX4759 (N_5–N_8)	+25°C		2.0	3.5	
			T <sub>MIN</sub> to T <sub>MAX</sub>			4	
On-Resistance Match Between Channels (Notes 4, 5)	ΔR <sub>ON</sub>	V+ = 2.7V, I <sub>COM_</sub> = 10mA, V <sub>NO_</sub> or V <sub>NC_</sub> = 1.5V	MAX4758, MAX4759 (N_1–N_4)	+25°C	0.1	0.35	Ω
			T <sub>MIN</sub> to T <sub>MAX</sub>			0.55	
		MAX4759 (N_5–N_8)	+25°C		0.2	0.4	
			T <sub>MIN</sub> to T <sub>MAX</sub>			0.55	
On-Resistance Flatness (Note 6)	R <sub>FLAT (ON)</sub>	V+ = 2.7V, I <sub>COM_</sub> = 10mA, V <sub>NC_</sub> or V <sub>NO_</sub> = 0 or V+	MAX4758, MAX4759 (N_1–N_4)	+25°C	0.2	0.45	Ω
			T <sub>MIN</sub> to T <sub>MAX</sub>			0.55	
		MAX4759 (N_5–N_8)	+25°C		0.8	1.5	
			T <sub>MIN</sub> to T <sub>MAX</sub>			1.8	
NO_, NC_ Off-Leakage Current	I <sub>NO_ (OFF)</sub> , I <sub>NC_ (OFF)</sub>	V+ = 3.6V; V <sub>COM_</sub> = 3.3V, 0.3V; V <sub>NO_</sub> or V <sub>NC_</sub> = 0.3V, 3.3V	+25°C	-5		+5	nA
			T <sub>MIN</sub> to T <sub>MAX</sub>			-25	
COM_ On-Leakage Current	I <sub>COM_ (ON)</sub>	V+ = 3.6V; V <sub>COM_</sub> = 3.3V, 0.3V; V <sub>NO_</sub> or V <sub>NC_</sub> = 3.3V, 0.3V, or floating	+25°C	-5		+5	nA
			T <sub>MIN</sub> to T <sub>MAX</sub>			-25	
<b>DYNAMIC</b>							
Turn-On Time	t <sub>ON</sub>	V+ = 2.7V, V <sub>NO_</sub> or V <sub>NC_</sub> = 1.5V; R <sub>L</sub> = 50Ω; C <sub>L</sub> = 35pF, Figure 2	+25°C		45	140	ns
			T <sub>MIN</sub> to T <sub>MAX</sub>			150	

# Quad DPDT Audio/Data Switches in UCSP/QFN

MAX4758/MAX4759

## ELECTRICAL CHARACTERISTICS (continued)

(V+ = +2.7V to +5.25V, T<sub>A</sub> = -40°C to +85°C, unless otherwise noted. Typical values are at V+ = 3V, T<sub>A</sub> = +25°C.) (Notes 2, 3)

PARAMETER	SYMBOL	CONDITIONS		T <sub>A</sub>	MIN	TYP	MAX	UNITS
Turn-Off Time	t <sub>OFF</sub>	V+ = 2.7V, V <sub>NO_</sub> or V <sub>NC_</sub> = 1.5V; R <sub>L</sub> = 50Ω; C <sub>L</sub> = 35pF, Figure 2		+25°C	25	50	60	ns
				T <sub>MIN</sub> to T <sub>MAX</sub>				
Break-Before-Make (Note 7)	t <sub>BBM</sub>	V+ = 2.7V, V <sub>NO_</sub> or V <sub>NC_</sub> = 1.5V; R <sub>L</sub> = 50Ω, C <sub>L</sub> = 35pF, Figure 3		+25°C	15		2	ns
				T <sub>MIN</sub> to T <sub>MAX</sub>				
Skew (Note 7)	t <sub>SKEW</sub>	R <sub>S</sub> = 39Ω, C <sub>L</sub> = 50pF, MAX4759 (COM5–COM8), Figure 4		+25°C	0.2	0.5	ns	
Charge Injection	Q	V <sub>GEN</sub> = 0, R <sub>GEN</sub> = 0, C <sub>L</sub> = 1.0nF, Figure 5	MAX4758, MAX4759 (COM1–COM4)	+25°C	40		pC	
			MAX4759 (COM5–COM8)		15			
On-Channel -3dB Bandwidth	BW	Signal = 0dBm, C <sub>L</sub> = 5pF, R <sub>L</sub> = 50Ω, MAX4758, MAX4759 (COM1–COM4)		+25°C	50		MHz	
		Signal = 0dBm, C <sub>L</sub> = 5pF, R <sub>L</sub> = 50Ω, MAX4759 (COM5–COM8)		+25°C	320			
Off-Isolation (Note 8)	V <sub>ISO</sub>	C <sub>L</sub> = 5pF, R <sub>L</sub> = 50Ω, V <sub>COM_</sub> = 1Vp-p, f = 100kHz, Figure 6		+25°C	-95		dB	
Crosstalk (Note 9)	V <sub>CT</sub>	C <sub>L</sub> = 5pF, R <sub>L</sub> = 50Ω, V <sub>COM_</sub> = 1Vp-p, f = 100kHz, Figure 6		+25°C	-100		dB	
Total Harmonic Distortion	THD	f = 20Hz to 20kHz, 1Vp-p	MAX4758, MAX4759 (N <sub>1</sub> –N <sub>4</sub> ), R <sub>L</sub> = 32Ω	+25°C	0.03		%	
			MAX4759 (N <sub>5</sub> –N <sub>8</sub> ), R <sub>L</sub> = 600Ω	+25°C	0.03			
NO <sub>_</sub> , NC <sub>_</sub> Off-Capacitance	C <sub>NO_(OFF)</sub> , C <sub>NC_(OFF)</sub>	V <sub>NO_</sub> , V <sub>NC_</sub> = GND, f = 1MHz, Figure 7	MAX4758, MAX4759 (N <sub>1</sub> –N <sub>4</sub> )	+25°C	102		pF	
			MAX4759 (N <sub>5</sub> –N <sub>8</sub> )	+25°C	25			
COM <sub>_</sub> On-Capacitance	C <sub>(ON)</sub>	V <sub>NO_</sub> , V <sub>NC_</sub> = GND, f = 1MHz, Figure 7	MAX4758, MAX4759 (COM1–COM4)	+25°C	284		pF	
			MAX4759 (COM5–COM8)	+25°C	54			
<b>DIGITAL I/O (IN<sub>_</sub>)</b>								
Input Logic High	V <sub>IH</sub>	V+ = 2.7V to 3.6V		T <sub>MIN</sub> to T <sub>MAX</sub>	1.4		V	
		V+ = 3.6V to 5.5V		T <sub>MIN</sub> to T <sub>MAX</sub>	2.0			
Input Logic Low	V <sub>IL</sub>	V+ = 2.7V to 3.6V		T <sub>MIN</sub> to T <sub>MAX</sub>	0.5		V	
		V+ = 3.6V to 5.5V		T <sub>MIN</sub> to T <sub>MAX</sub>	0.6			
Input Leakage Current	I <sub>IN</sub>	V <sub>IN</sub> = 0 or V+		T <sub>MIN</sub> to T <sub>MAX</sub>	1		μA	

# Quad DPDT Audio/Data Switches in UCSP/QFN

## ELECTRICAL CHARACTERISTICS (continued)

(V+ = +2.7V to +5.25V, T<sub>A</sub> = -40°C to +85°C, unless otherwise noted. Typical values are at V+ = 3V, T<sub>A</sub> = +25°C.) (Notes 2, 3)

PARAMETER	SYMBOL	CONDITIONS	T <sub>A</sub>	MIN	TYP	MAX	UNITS
<b>POWER SUPPLY</b>							
Power-Supply Range	V+		T <sub>MIN</sub> to T <sub>MAX</sub>	1.8		5.5	V
Positive Supply Current	I+	V+ = 5.5V, V <sub>IN-</sub> = 0V or V+	+25°C	0.01			μA
			T <sub>MIN</sub> to T <sub>MAX</sub>		1.0		

- Note 2:** The algebraic convention is used in this data sheet; the most negative value is shown in the minimum column.
- Note 3:** UCSP packages are 100% tested at +25°C and limits across the full temperature range are guaranteed by correlation and design. Thin QFN parts are 100% tested at +85°C and limits across the full temperature range are guaranteed by correlation and design.
- Note 4:** R<sub>ON</sub> and ΔR<sub>ON</sub> matching specifications are guaranteed by design.
- Note 5:** ΔR<sub>ON</sub> = R<sub>ON</sub>(MAX) - R<sub>ON</sub>(MIN).
- Note 6:** Flatness is defined as the difference between the maximum and minimum value of on-resistance as measured over the specified analog signal ranges.
- Note 7:** Guaranteed by design, not production tested.
- Note 8:** Off-isolation = 20log<sub>10</sub> [V<sub>COM-</sub> / (V<sub>NO-</sub> or V<sub>NC-</sub>)], V<sub>COM-</sub> = output, V<sub>NO-</sub> or V<sub>NC-</sub> = input to off switch.
- Note 9:** Between any two switches.

## Typical Operating Characteristics

(V+ = 3V, T<sub>A</sub> = +25°C, unless otherwise noted.)

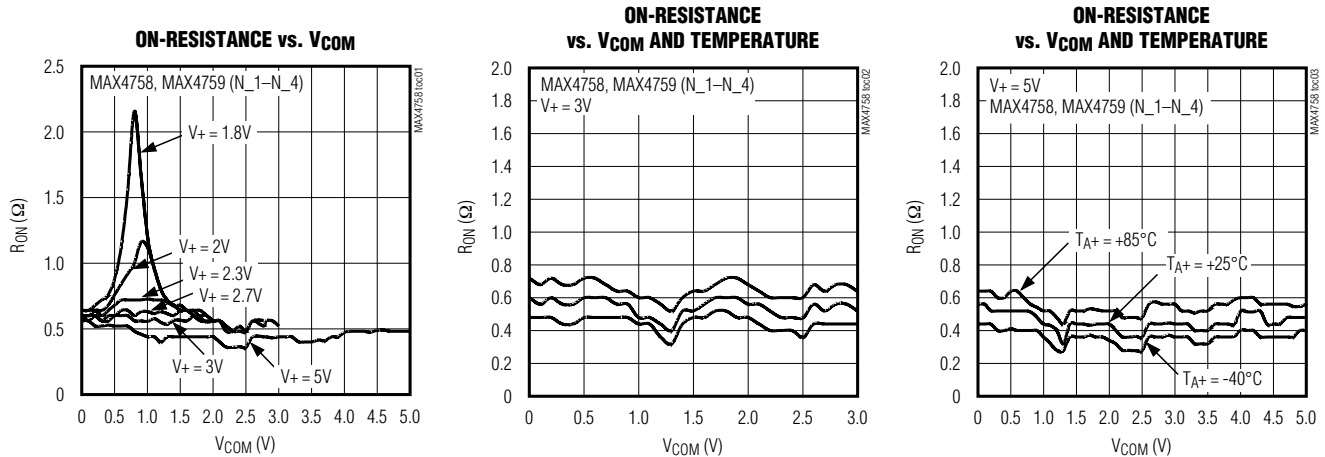

# Quad DPDT Audio/Data Switches in UCSP/QFN

MAX4758/MAX4759

## Typical Operating Characteristics (continued)

( $V_+ = 3V$ ,  $T_A = +25^\circ C$ , unless otherwise noted.)

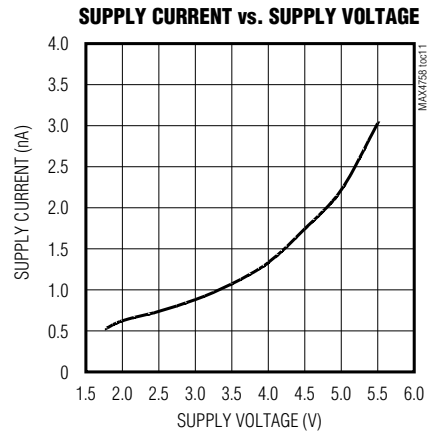
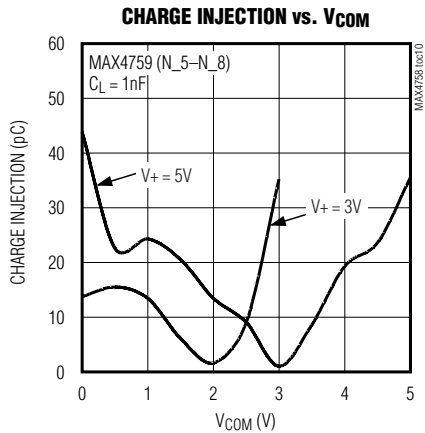
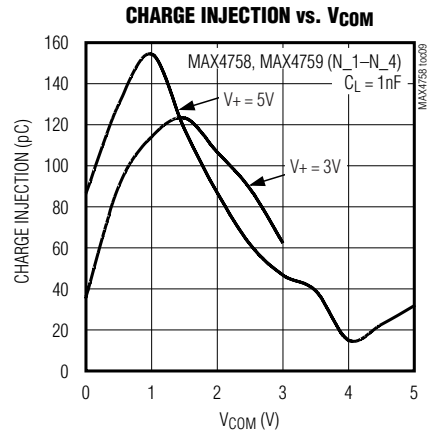
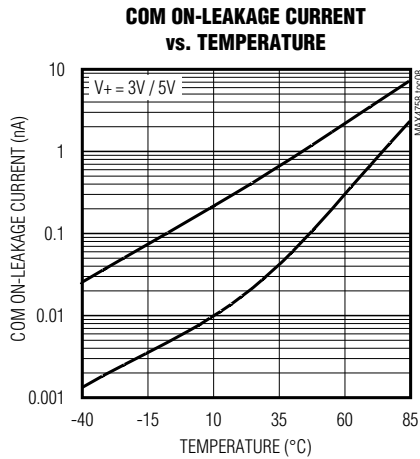
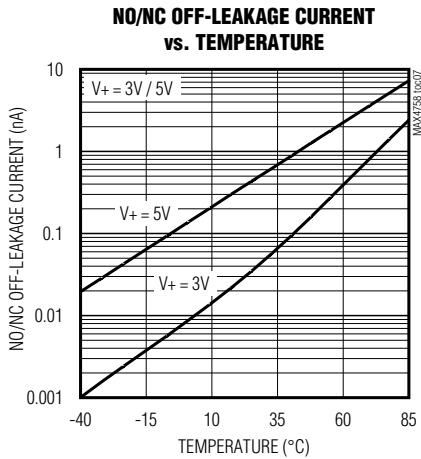
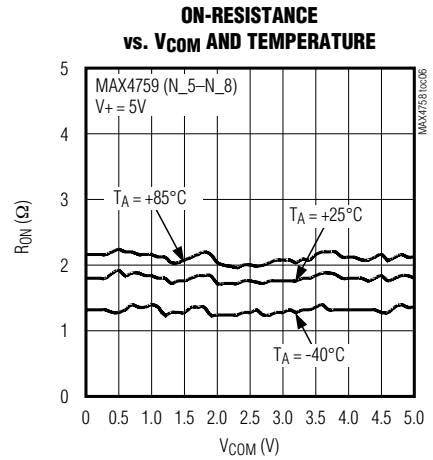
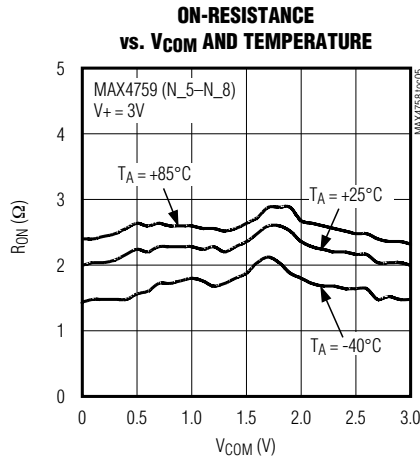
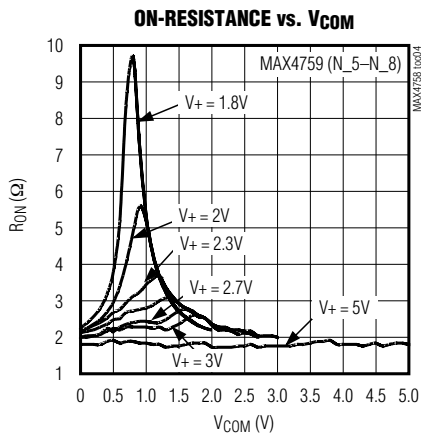

# Quad DPDT Audio/Data Switches in UCSP/QFN

## Typical Operating Characteristics (continued)

( $V_+ = 3V$ ,  $T_A = +25^\circ C$ , unless otherwise noted.)

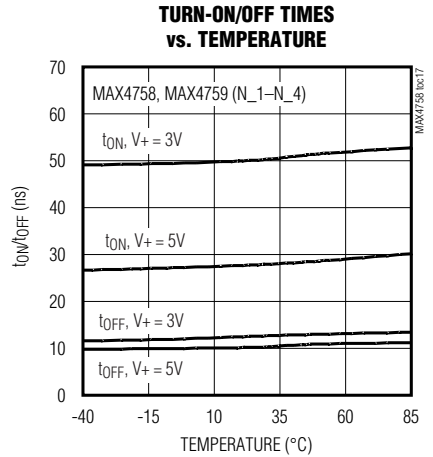
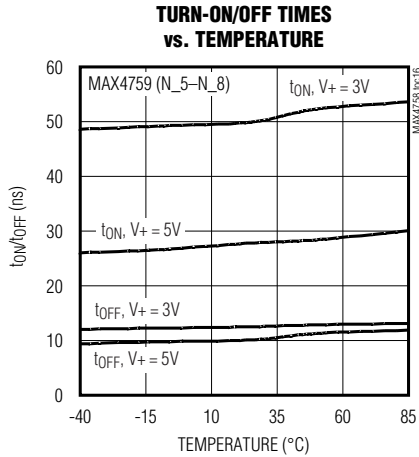
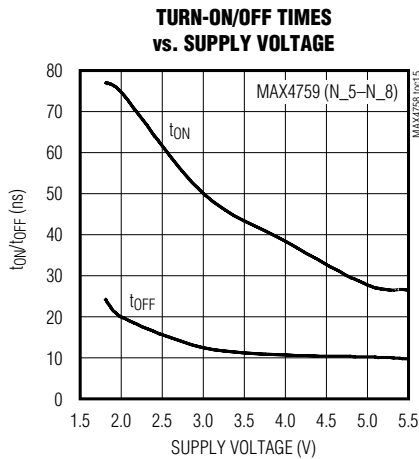
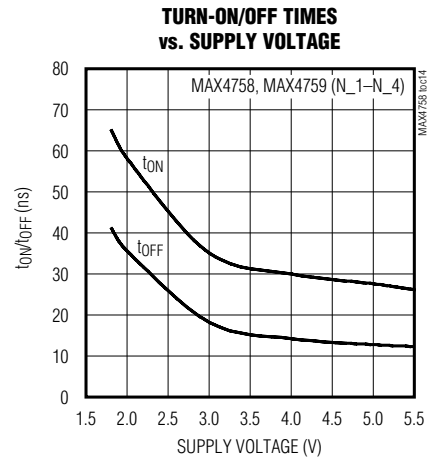
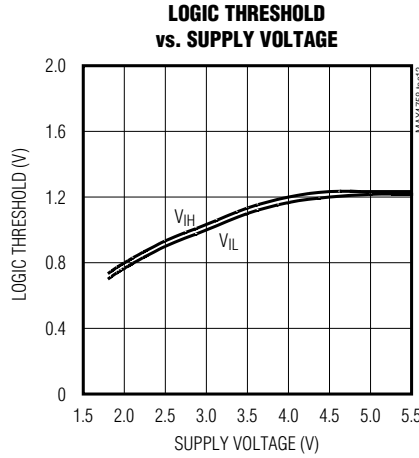
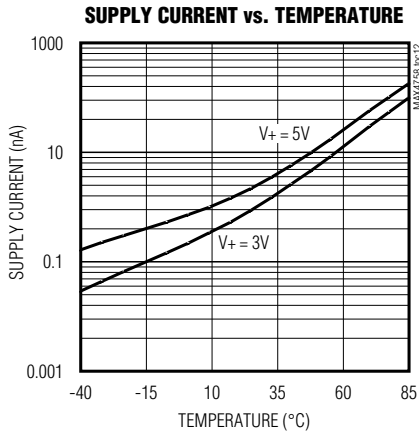

# Quad DPDT Audio/Data Switches in UCSP/QFN

MAX4758/MAX4759

## Typical Operating Characteristics (continued)

( $V_+ = 3V$ ,  $T_A = +25^\circ C$ , unless otherwise noted.)

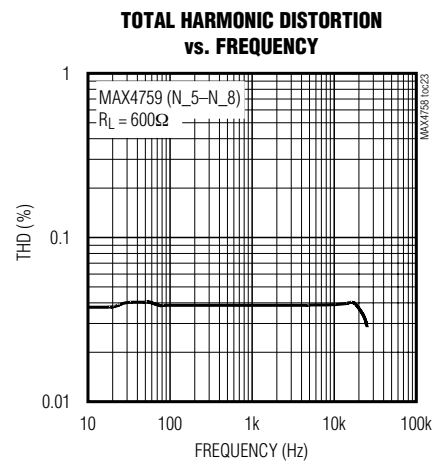
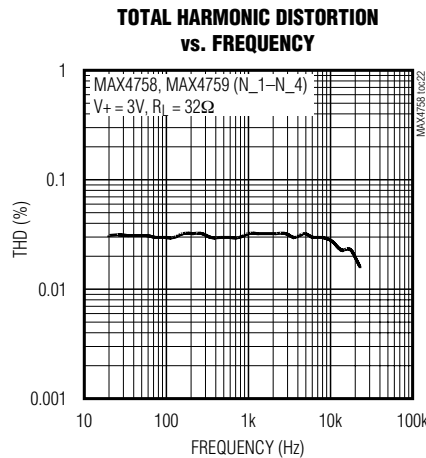
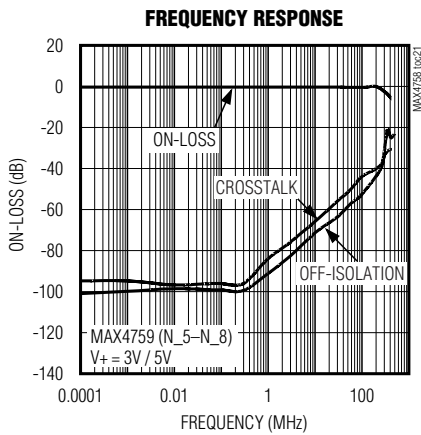
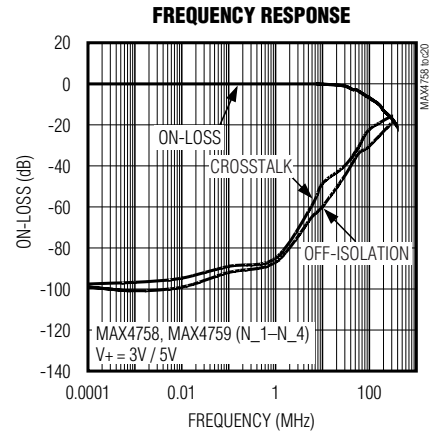
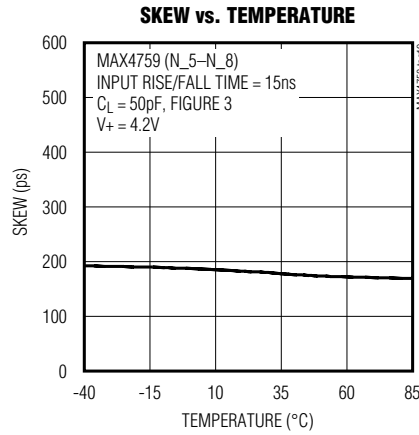
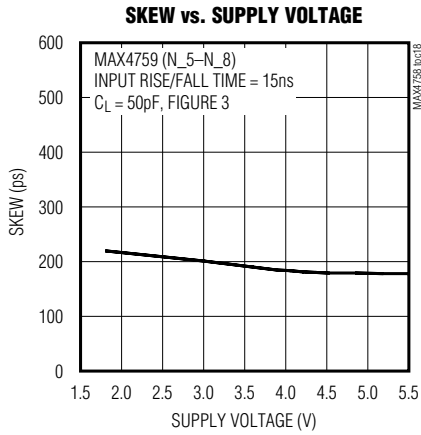

# Quad DPDT Audio/Data Switches in UCSP/QFN

## Pin Description

MAX4758/MAX4759

PIN				NAME	FUNCTION
MAX4758		MAX4759			
THIN QFN	UCSP	THIN QFN	UCSP		
1	A1	1	A1	NC1	Analog Switch 1, Normally Closed Terminal 1
2	B2	2	B2	COM2	Analog Switch 2, Common Terminal 2
3	A2	3	A2	NC2	Analog Switch 2, Normally Closed Terminal 2
4	A3	4	A3	INA	Logic Control Digital Input for Switches 1 and 2
5	C3, D4	5	C3, D4	V+	Positive Supply Voltage
6	A4	6	A4	INB	Logic Control Digital Input for Switches 3 and 4
7	A5	7	A5	NC3	Analog Switch 3, Normally Closed Terminal 3
8	B5	8	B5	COM3	Analog Switch 3, Common Terminal 3
9	A6	9	A6	NC4	Analog Switch 4, Normally Closed Terminal 4
10	B6	10	B6	COM4	Analog Switch 4, Common Terminal 4
11, 14, 17, 29, 32, 35	—	11, 14, 17, 29, 32, 35	—	N.C.	No Connection. Not internally connected.
12	C5	12	C5	NO3	Analog Switch 3, Normally Open Terminal 3
13	C6	13	C6	NO4	Analog Switch 4, Normally Open Terminal 4
15	D6	15	D6	NO8	Analog Switch 8, Normally Open Terminal 8
16	D5	16	D5	NO7	Analog Switch 7, Normally Open Terminal 7
18	E6	18	E6	COM8	Analog Switch 8, Common Terminal 8
19	F6	19	F6	NC8	Analog Switch 8, Normally Closed Terminal 8
20	E5	20	E5	COM7	Analog Switch 7, Common Terminal 7
21	F5	21	F5	NC7	Analog Switch 7, Normally Closed Terminal 7
22	F4	22	F4	IND	Logic Control Digital Input for Switches 7 and 8
23	C4, D3	23	C4, D3	GND	Ground
24	F3	24	F3	INC	Logic Control Digital Input for Switches 5 and 6
25	F2	25	F2	NC6	Analog Switch 6, Normally Closed Terminal 2
26	E2	26	E2	COM6	Analog Switch 6, Common Terminal 6
27	F1	27	F1	NC5	Analog Switch 5, Normally Closed Terminal 5
28	E1	28	E1	COM5	Analog Switch 5, Common Terminal 5
30	D2	30	D2	NO6	Analog Switch 6, Normally Open Terminal 6
31	D1	31	D1	NO5	Analog Switch 5, Normally Open Terminal 5
33	C1	33	C1	NO1	Analog Switch 1, Normally Open Terminal 1
34	C2	34	C2	NO2	Analog Switch 2, Normally Open Terminal 2
36	B1	36	B1	COM1	Analog Switch 1, Common Terminal 1
—	—	—	—	$\overline{EN}$	Output Enable, Active Low
EP	—	EP	—	EP	Exposed Pad. Connect to GND



# Quad DPDT Audio/Data Switches in UCSP/QFN

## Detailed Description

The MAX4758/MAX4759 quad DPDT analog switches operate from a single +1.8V to +5.5V supply. These devices are fully specified for +3V applications.

The MAX4758/MAX4759 (switches 1–4) have a guaranteed 0.5Ω on-resistance, making them ideal for audio switching applications. The MAX4759 also includes four single-pole/double-throw (SPDT) switches (switches 5–8) that have a guaranteed 0.2Ω on-resistance, a low 25pF capacitance, 0.2ns change in skew making them ideal for either data or audio switching applications. These switches have four logic inputs to control two switches in pairs.

## Applications Information

### Digital Control Inputs

The MAX4758/MAX4759 logic inputs accept up to +5.5V regardless of the supply voltage. For example, with a +3.3V supply, IN<sub>-</sub> can be driven low to GND and high to +5.5V, which allows mixed logic levels in a system. Driving the control logic inputs rail-to-rail also minimizes power consumption. For a +3V supply voltage, the logic thresholds are 0.5V (low) and 1.4V (high).

### Analog Signal Levels

Analog signal inputs over the full voltage range (0V to V<sub>+</sub>) are passed through the switch with minimal change in on-resistance (see the *Typical Operating Characteristics*). The switches are bidirectional so NO<sub>-</sub>, NC<sub>-</sub>, and COM<sub>-</sub> can be either inputs or outputs.

### Power-Supply Bypassing

Power-supply bypassing improves noise margin and prevents switching noise from propagating from the V<sub>+</sub> supply to other components. A 0.1μF capacitor connected from V<sub>+</sub> to GND is adequate for most applications.

### Power-Supply Sequencing

CMOS devices require proper power-supply sequencing. Always apply V<sub>+</sub> before the analog signals, espe-

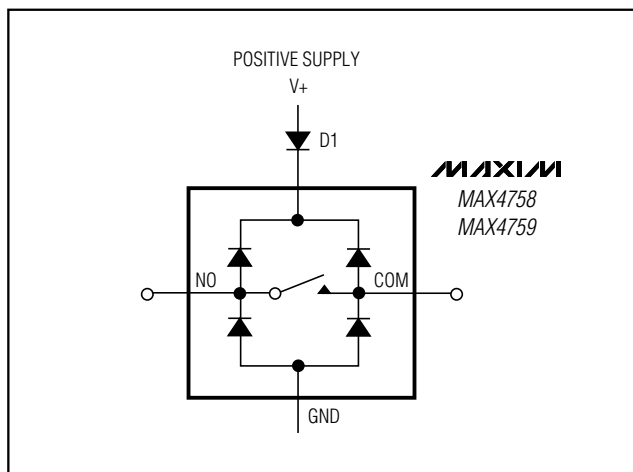

Figure 1. Overvoltage Protection Using an External Blocking Diode

cially if the input signal is not current limited. If sequencing is not possible, and the input signal is not current limited to less than 20mA, add a small-signal diode (Figure 1). Adding the diode reduces the analog range to a diode drop (0.7V) below V<sub>+</sub> and increases the on-resistance slightly. The maximum supply voltage must not exceed +6V at any time.

## UCSP Applications Information

For the latest application details on UCSP construction, dimensions, tape carrier information, PC board techniques, bump-pad layout, and recommended reflow temperature profile, as well as the latest information on reliability testing results, go to the Maxim website at [www.maxim-ic.com/ucsp](http://www.maxim-ic.com/ucsp) for the Application Note, "UCSP—A Wafer-Level Chip-Scale Package".

MAX4758/MAX4759

# Quad DPDT Audio/Data Switches in UCSP/QFN

## Timing Circuits/Timing Diagrams

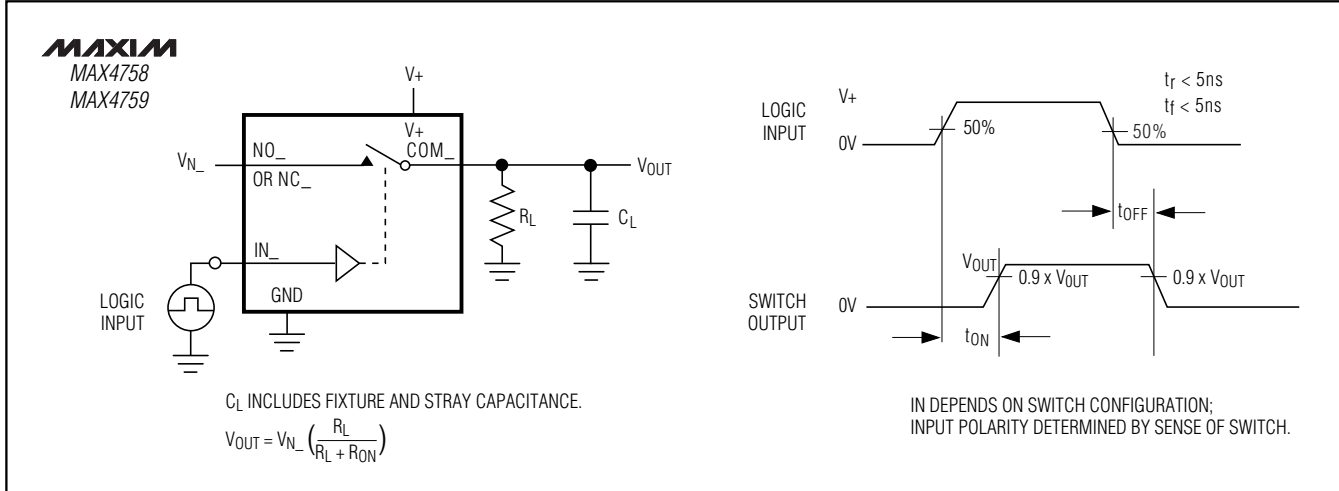

Figure 2. Switching Time

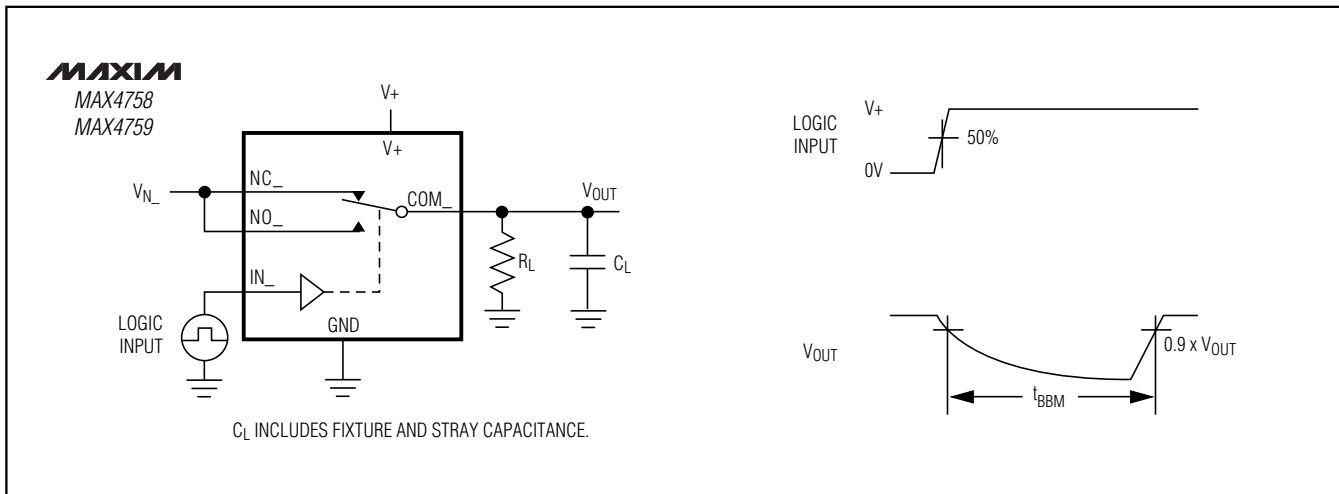

Figure 3. Break-Before-Make Interval

# Quad DPDT Audio/Data Switches in UCSP/QFN

MAX4758/MAX4759

## Timing Circuits/Timing Diagrams (continued)

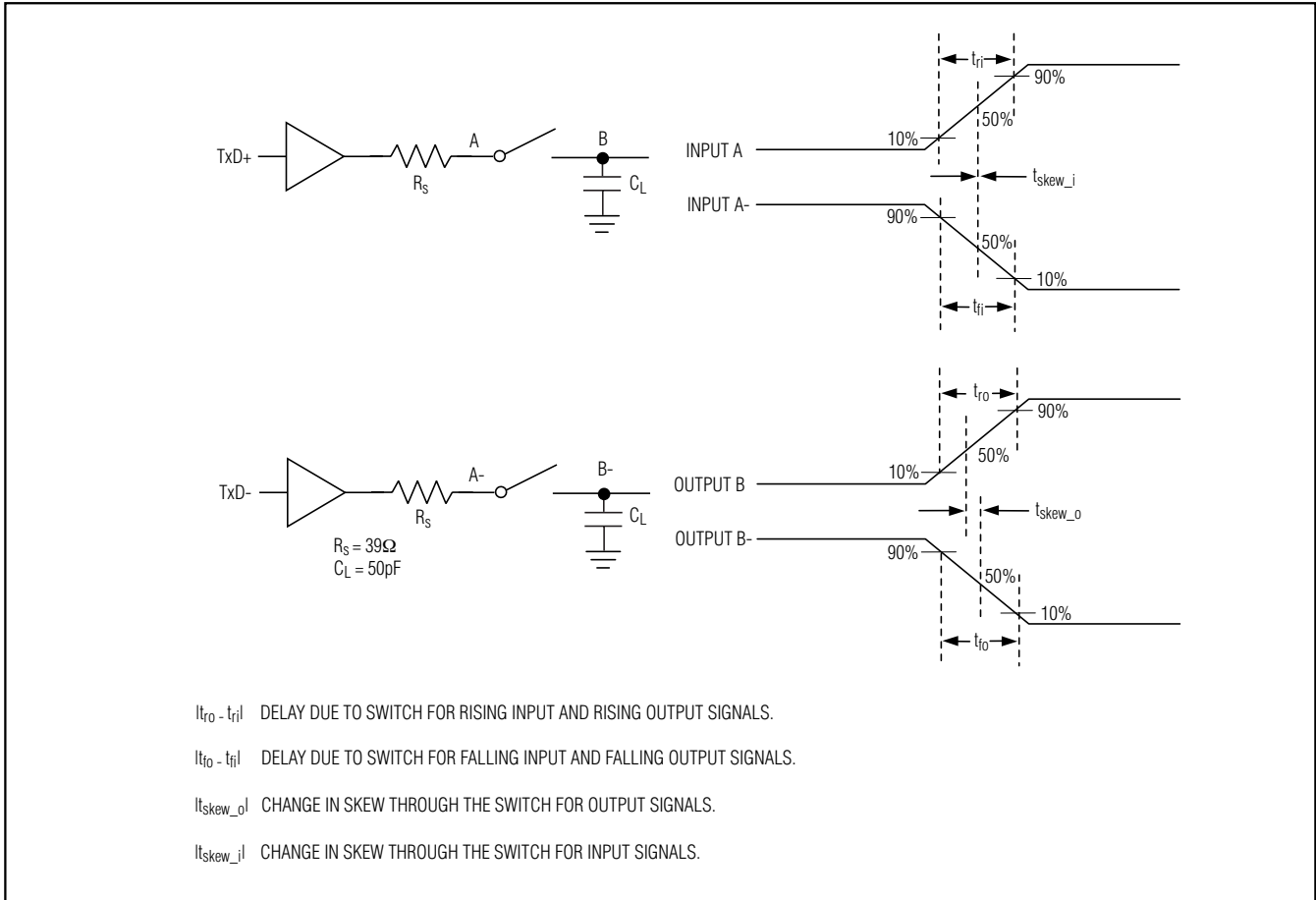

Figure 4. Input/Output Skew Timing Diagram

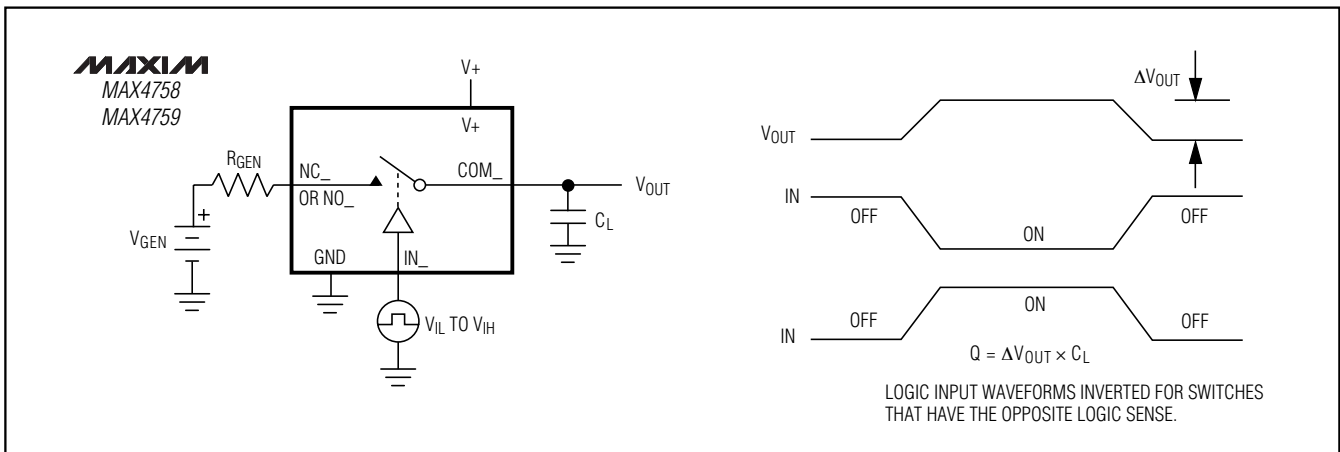

Figure 5. Charge Injection

# Quad DPDT Audio/Data Switches in UCSP/QFN

## Timing Circuits/Timing Diagrams (continued)

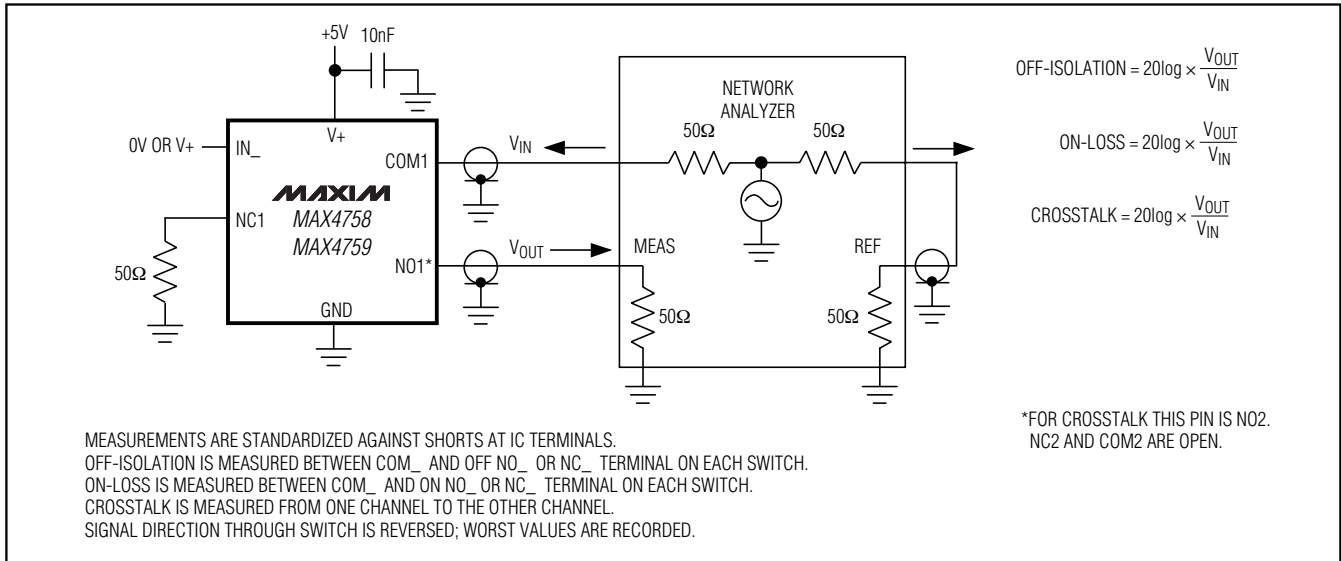

Figure 6. On-Loss, Off-Isolation, and Crosstalk

## Typical Operating Circuit

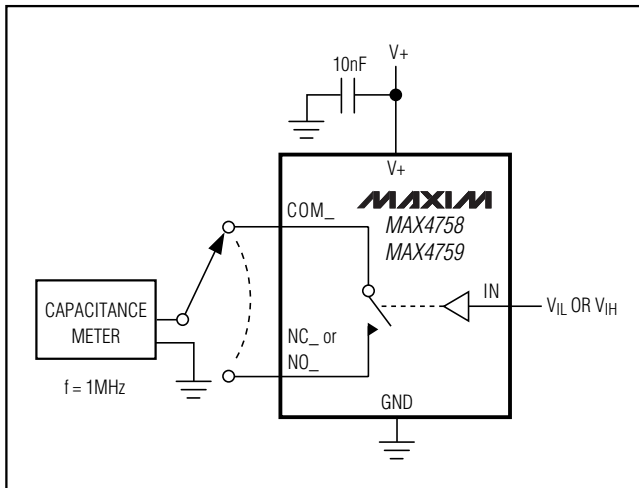
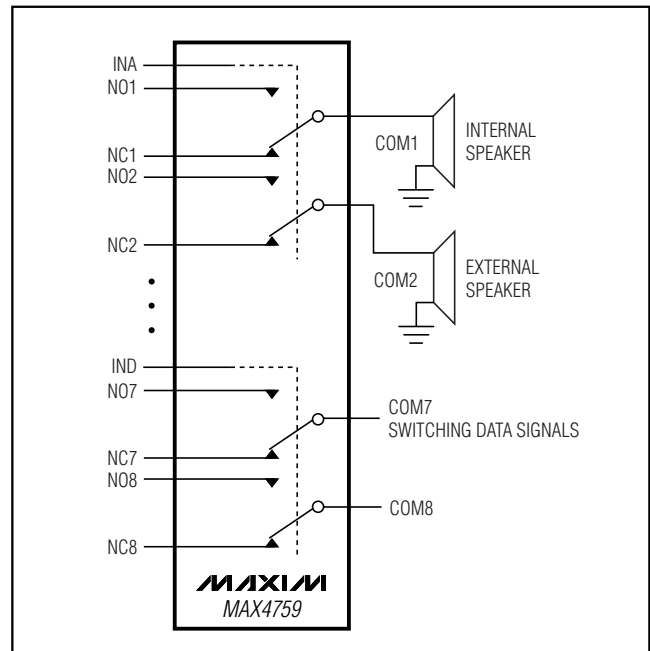

Figure 7. Channel On-/Off-Capacitance



# Quad DPDT Audio/Data Switches in UCSP/QFN

## Pin Configurations/Truth Tables

**MAX4758/MAX4759**

TOP VIEW

**MAXIM**  
MAX4758/MAX4759

(BUMP SIDE DOWN)

**UCSP**  
MAX4758/MAX4759

INA	NO1/NO2	NC1/NC2
LOW	OFF	ON
HIGH	ON	OFF
INB	NO3/NO4	NC3/NC4
LOW	OFF	ON
HIGH	ON	OFF
INC	NO5/NO6	NC5/NC6
LOW	OFF	ON
HIGH	ON	OFF
IND	NO7/NO8	NC7/NC8
LOW	OFF	ON
HIGH	ON	OFF

**THIN QFN**

**NOTE:** EXPOSED PADDLE CONNECTED TO GND OR FLOATING.

### Chip Information

TRANSISTOR COUNT: 1432

PROCESS: CMOS

# Quad DPDT Audio/Data Switches in UCSP/QFN

## Package Information

(The package drawing(s) in this data sheet may not reflect the most current specifications. For the latest package outline information, go to [www.maxim-ic.com/packages](http://www.maxim-ic.com/packages).)

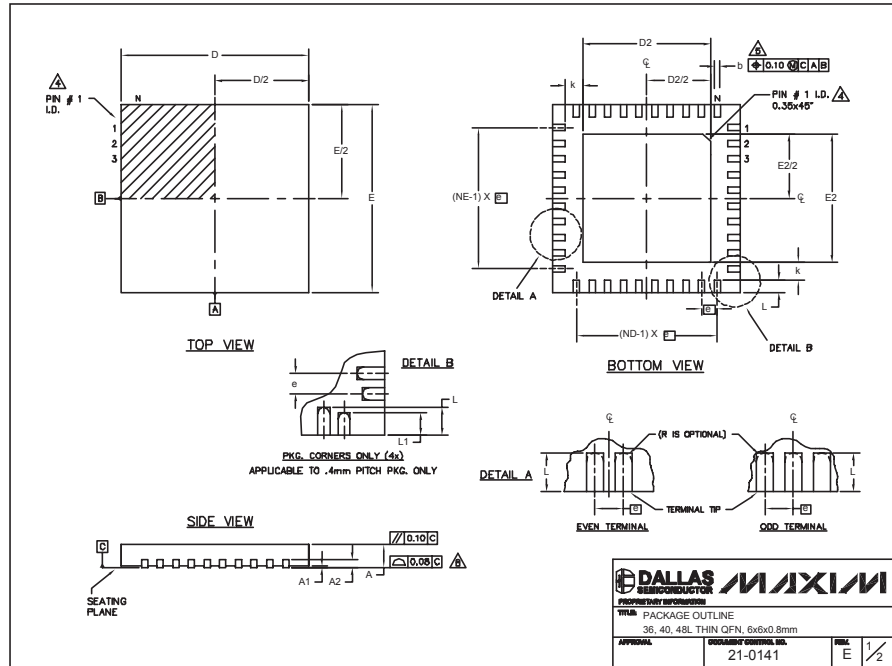

COMMON DIMENSIONS										
PKG.	36L 6x6			40L 6x6			48L 6x6			
	SYMBOL	MIN.	NOM.	MAX.	MIN.	NOM.	MAX.	MIN.	NOM.	MAX.
A	0.70	0.75	0.80	0.70	0.75	0.80	0.70	0.75	0.80	
A1	0	0.02	0.05	0	0.02	0.05	0			0.05
A2	0.20 REF.			0.20 REF.			0.20 REF.			
b	0.20	0.25	0.30	0.20	0.25	0.30	0.15	0.20	0.25	
D	5.80	6.00	6.10	5.80	6.00	6.10	5.80	6.00	6.10	
E	5.80	6.00	6.10	5.80	6.00	6.10	5.80	6.00	6.10	
e	0.50 BSC.			0.50 BSC.			0.40 BSC.			
k	0.25	-	-	0.25	-	-	0.25	0.35	0.45	
L	0.45	0.55	0.65	0.30	0.40	0.50	0.40	0.50	0.60	
L1	-	-	-	-	-	-	0.30	0.40	0.50	
N	36			40			48			
ND	9			10			12			
NE	9			10			12			
JEDEC	WJ4D-1			WJ4D-2			-			

PKG. CODES	EXPOSED PAD VARIATIONS						DOWN BONDS ALLOWED
	D2			E2			
	MIN.	NOM.	MAX.	MIN.	NOM.	MAX.	
T3666-1	3.60	3.70	3.80	3.60	3.70	3.80	NO
T3666-2	3.60	3.70	3.80	3.60	3.70	3.80	YES
T3666-3	3.60	3.70	3.80	3.60	3.70	3.80	NO
T4066-1	4.00	4.10	4.20	4.00	4.10	4.20	NO
T4066-2	4.00	4.10	4.20	4.00	4.10	4.20	YES
T4066-3	4.00	4.10	4.20	4.00	4.10	4.20	YES
T4066-4	4.00	4.10	4.20	4.00	4.10	4.20	NO
T4066-5	4.00	4.10	4.20	4.00	4.10	4.20	NO
T4866-1	4.20	4.30	4.40	4.20	4.30	4.40	YES

NOTES:

- DIMENSIONING & TOLERANCING CONFORM TO ASME Y14.5M-1994.
- ALL DIMENSIONS ARE IN MILLIMETERS. ANGLES ARE IN DEGREES.
- N IS THE TOTAL NUMBER OF TERMINALS.
- THE TERMINAL #1 IDENTIFIER AND TERMINAL NUMBERING CONVENTION SHALL CONFORM TO JESD 95-1 SPP-012. DETAILS OF TERMINAL #1 IDENTIFIER ARE OPTIONAL, BUT MUST BE LOCATED WITHIN THE ZONE INDICATED. THE TERMINAL #1 IDENTIFIER MAY BE EITHER A MOLD OR MARKED FEATURE.
- DIMENSION b APPLIES TO METALLIZED TERMINAL AND IS MEASURED BETWEEN 0.25 mm AND 0.30 mm FROM TERMINAL TIP.
- ND AND NE REFER TO THE NUMBER OF TERMINALS ON EACH D AND E SIDE RESPECTIVELY.
- DEPOPULATION IS POSSIBLE IN A SYMMETRICAL FASHION.
- COPLANARITY APPLIES TO THE EXPOSED HEAT SINK SLUG AS WELL AS THE TERMINALS.
- DRAWING CONFORMS TO JEDEC MO220, EXCEPT FOR 0.4mm LEAD PITCH PACKAGE T4866-1.
- WARPAGE SHALL NOT EXCEED 0.10 mm.

<b>DALLAS SEMICONDUCTOR</b>	
MAXIM	
PROPRIETARY INFORMATION	
TITLE PACKAGE OUTLINE	
36, 40, 48L THIN QFN, 6x6x0.8mm	
APPROVAL	DOCUMENT CONTROL NO.
	21-0141
REV	E
	1/2

# Quad DPDT Audio/Data Switches in UCSP/QFN

## Package Information (continued)

(The package drawing(s) in this data sheet may not reflect the most current specifications. For the latest package outline information, go to [www.maxim-ic.com/packages](http://www.maxim-ic.com/packages).)

MAX4758/MAX4759

**TOP VIEW**

COMMON DIMENSIONS	
A	0.62±0.05-0.08
A1	0.29±0.02
A2	0.33 REF.
b	∅0.35±0.03
D	3.06±0.10
D1	2.50 BASIC
E	3.06±0.10
E1	2.50 BASIC
e	0.50 BASIC
SD	0.25 BASIC
SE	0.25 BASIC

PKG. CODE	DEPOPULATED SOLDER BALLS
B36-1	NONE
B36-2	B3, B4, E3, E4
B36-3	B4, B5, C3, C4, C5, D3, D4, D5, E4, E5

**NOTES:**  
 1. ALL DIMENSIONS ARE IN MILLIMETERS.  
 2. PRODUCT MARKING: NUMBER OF CHARACTERS AND LINES VARY PER PRODUCT.

**SIDE VIEW**

**BOTTOM VIEW**

	DALLAS SEMICONDUCTOR	MAXIM
PROPRIETARY INFORMATION		
TITLE: PACKAGE OUTLINE, 6x6 UCSP		
APPROVAL	DOCUMENT CONTROL NO. 21-0082	REV. J 1/1

36L\_UCSP.EPS

Maxim cannot assume responsibility for use of any circuitry other than circuitry entirely embodied in a Maxim product. No circuit patent licenses are implied. Maxim reserves the right to change the circuitry and specifications without notice at any time.

**Maxim Integrated Products, 120 San Gabriel Drive, Sunnyvale, CA 94086 408-737-7600** \_\_\_\_\_ **15**