



4-BIT MICROCONTROLLER

GENERAL DESCRIPTION

The W541C260 is cost down version of W741C260 and all function are same as W741C260. It is a high-performance 4-bit microcontroller (μC) with an LCD driver. The device contains a 4-bit ALU, two 8-bit timers, two dividers, a 32×4 LCD driver, and five 4-bit I/O ports (including 1 output port to drive the LEDs). There are also five interrupt sources and 8-level subroutine nesting for interrupt applications. The W541C260 has one power reduction mode to help minimize power dissipation.

The W541C260 has two oscillator circuits and can work in dual-clock or single-clock operation mode. It is suitable for remote controllers, watches and clocks, speech synthesis LSI controllers, and other products.

FEATURES

- Operating voltage: 2.4V–5.5V (LCD drive voltage: 3.0V, or 4.5V)
- Single or Dual Clock Mode
 - Single (main oscillator only) or dual clock (both main and sub-oscillator) by mask option .
 - Sub-oscillator is only 32.768 KHz crystal for dual clock mode.
 - Main oscillator is crystal or RC oscillation by mask code option .
 - Main clock : High-frequency clock (400 KHz to 4 MHz) or low-frequency clock (32.768 KHz) is selected by mask code option
- Memory
 - 2048 \times 16 bit program ROM (including 2K \times 4 bit look-up table)
 - 128 \times 4 bit data RAM (including 16 working registers)
 - 32 \times 4 LCD data RAM
- 21 input/output pins
 - Ports for input only: 2 ports/8 pins
 - Input/output ports: 2 ports/8 pins
 - Port for output only: 1 port /4 pins (high sink current to drive LEDs)
 - MFP output pin: 1 pin (MFP)
- Power-down mode
 - Hold function: no operation (except for oscillator)
 - Stop function: no operation (including main clock)
- Five types of interrupts
 - Four internal interrupts (Divider 0, Divider 1, Timer 0, Timer 1)
 - One external interrupt (Port RC)



- LCD driver output
 - 32 segment × 4 common
 - Static, 1/2 duty (1/2 bias), 1/3 duty (1/2 or 1/3 bias), 1/4 duty (1/3 bias) driving mode can be selected
 - LCD driver output pins can be used as DC output ports; selectable by code option
- MFP output pin
 - Output is software selectable as modulating or nonmodulating frequency
 - Works as frequency output specified by Timer 1
- Two built-in 14-bit clock frequency divider circuit (divider 0 and divider 1)
- Two built-in 8-bit programmable countdown timers
 - Timer 0: one of two internal clock frequencies ($F_{OSC}/4$ or $F_{OSC}/1024$) can be selected
 - Timer 1: includes an auto-reload function; and one of two internal clock frequencies (F_{OSC} or $F_{OSC}/64$) can be selected or falling edge of pin RC.0 can be selected (output through MFP pin)
- Built-in 18/14-bit watchdog timer selectable for system reset
- Powerful instruction set: 115 instructions
- 8-level subroutine (include interrupt) nesting
- Up to 1 μ S instruction cycle (with 4 MHz operating frequency)
- Packaged in 80-pin QFP



BLOCK DIAGRAM

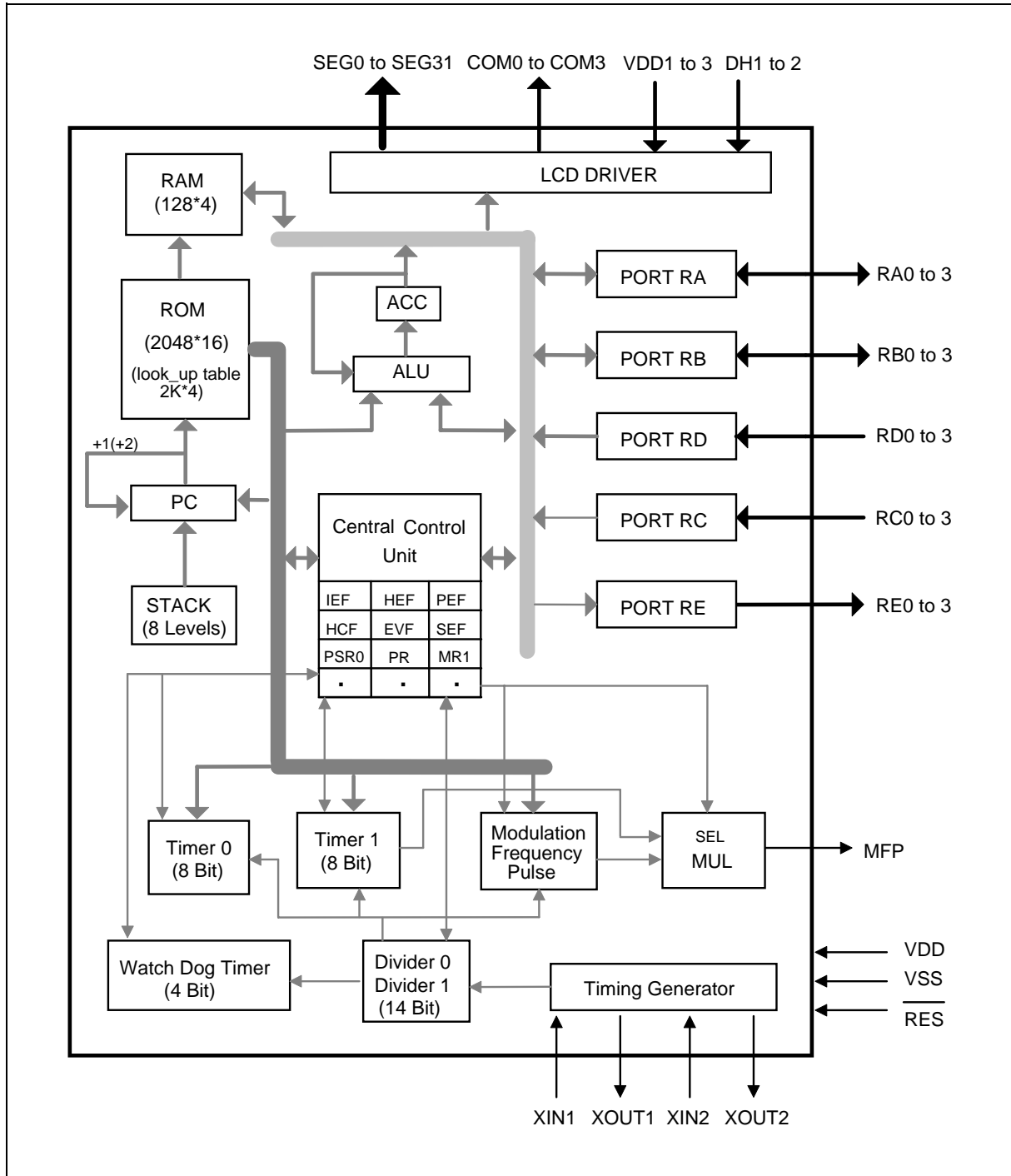

PIN CONFIGURATION

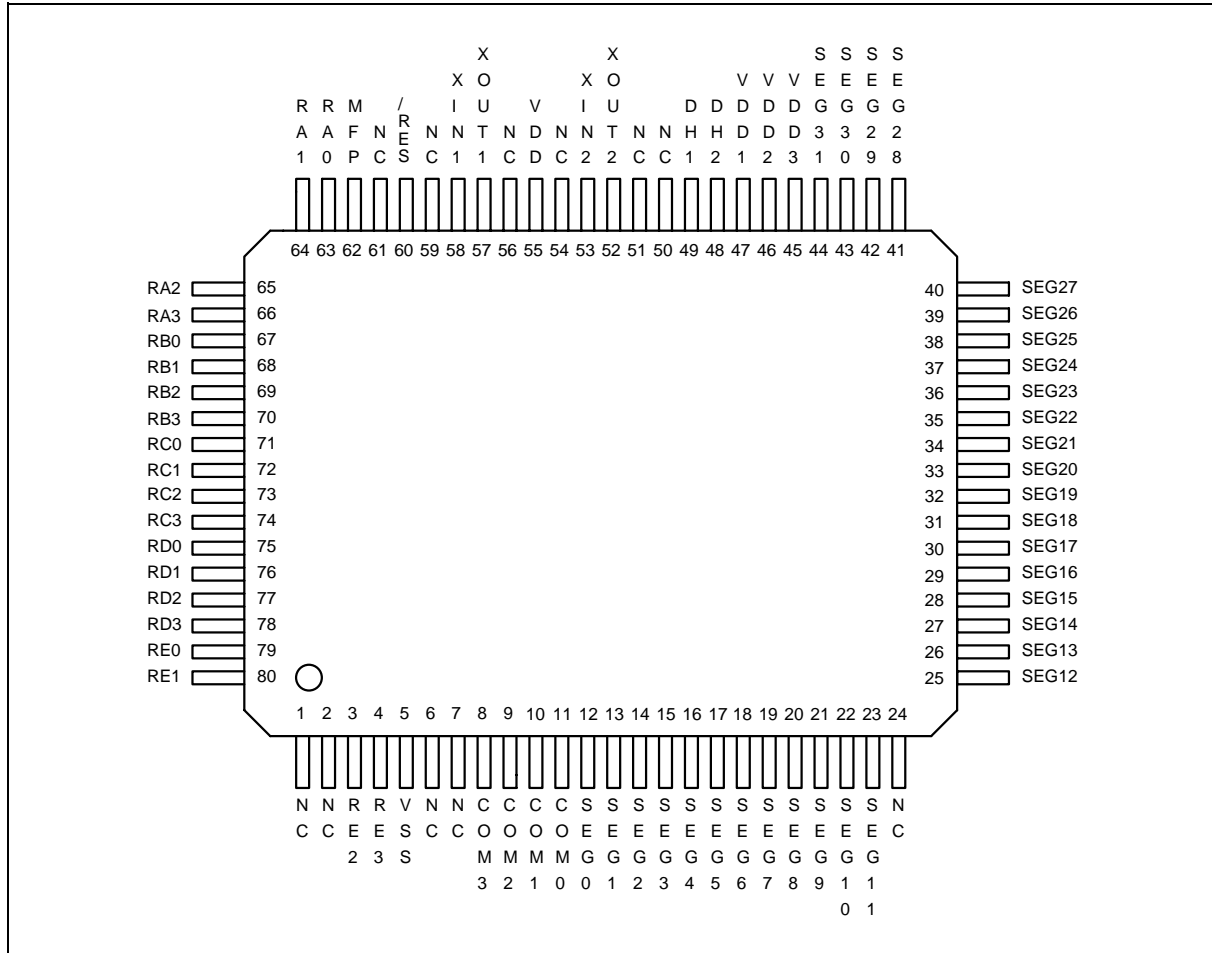



PAD DESCRIPTION

SYMBOL	I/O	FUNCTION																									
XIN1	I	Input pin for oscillator. Connected to crystal or resistor to generate system clock by code option. External 15~20pF capacitor uses to get accurate freq in crystal mode.																									
XOUT1	O	Output pin for oscillator. Connected to crystal or resistor to generate system clock by code option. 20PF capacitor is built in internal for crystal mode.																									
XIN2	I	Input pin for sub-oscillator. Connected to a 32.768 KHz crystal. External 15~20pF capacitor uses to get accurate freq in crystal mode.																									
XOUT2	O	Output pin for sub-oscillator. Connected to a 32.768 KHz crystal. 20PF capacitor is built in internal for crystal mode.																									
RA0~RA3	I/O	Input/Output port. Input/output mode specified by port mode 1 register (PM1).																									
RB0~RB3	I/O	Input/Output port. Input/output mode specified by port mode 2 register (PM2).																									
RC0~RC3	I	4-bit port for input only. Each pin has an independent interrupt capability.																									
RD0~RD3	I	4-bit port for input only.																									
RE0~RE3	O	Output port only. This port provides high sink current to drive LEDs.																									
MFP	O	Output pin only. This pin can output modulating or nonmodulating frequency, or Timer 1 clock output specified by mode register 1 (MR1).																									
$\overline{\text{RES}}$	I	System reset pin with pull-high resistor.																									
SEG0~SEG31	O	LCD segment output pins. Can also be used as DC output ports specified by code option.																									
COM0~COM3	O	LCD common signal output pins. <table border="1" style="margin-left: 20px;"> <thead> <tr> <th></th> <th>Static</th> <th>1/2 Duty</th> <th>1/3 Duty</th> <th>1/4 Duty</th> </tr> </thead> <tbody> <tr> <td>COM0</td> <td>Used</td> <td>Used</td> <td>Used</td> <td>Used</td> </tr> <tr> <td>COM1</td> <td>Not Used</td> <td>Used</td> <td>Used</td> <td>Used</td> </tr> <tr> <td>COM2</td> <td>Not Used</td> <td>Not Used</td> <td>Used</td> <td>Used</td> </tr> <tr> <td>COM3</td> <td>Not Used</td> <td>Not Used</td> <td>Not Used</td> <td>Used</td> </tr> </tbody> </table> <p>The LCD alternating frequency can be selected by code option.</p>		Static	1/2 Duty	1/3 Duty	1/4 Duty	COM0	Used	Used	Used	Used	COM1	Not Used	Used	Used	Used	COM2	Not Used	Not Used	Used	Used	COM3	Not Used	Not Used	Not Used	Used
	Static	1/2 Duty	1/3 Duty	1/4 Duty																							
COM0	Used	Used	Used	Used																							
COM1	Not Used	Used	Used	Used																							
COM2	Not Used	Not Used	Used	Used																							
COM3	Not Used	Not Used	Not Used	Used																							
DH1, DH2	I	Connection terminals for voltage doubler (halver) capacitor.																									
VDD1, VDD2 VDD3	I	Positive (+) supply voltage terminal. Refer to Functional Description.																									
VDD	I	Positive power supply (+).																									
VSS	I	Negative power supply (-).																									



ABSOLUTE MAXIMUM RATINGS

PARAMETER	RATING	UNIT
Supply Voltage to Ground Potential	-0.3 to +7.0	V
Applied Input/Output Voltage	-0.3 to +7.0	V
Power Dissipation	120	mW
Ambient Operating Temperature	0 to +70	°C
Storage Temperature	-55 to +150	°C

Note: Exposure to conditions beyond those listed under Absolute Maximum Ratings may adversely affect the life and reliability of the device.

DC CHARACTERISTICS

(V_{DD}-V_{SS} = 3.0V, F_m = 4 MHz, F_s = 32.768 KHz, T_A = 25° C, LCD on; unless otherwise specified)

PARAMETER	SYM.	CONDITIONS	MIN.	TYP.	MAX.	UNIT
Op. Voltage	V _{DD}	-	2.4	-	5.5	V
Op. Current (Crystal Type)	I _{OP1}	No load (Ext-V) In dual-clock normal operation	-	0.6	2.5	mA
Op. Current (RC Type)	I _{OP2}	No load (Ext-V) In dual-clock normal operation	-	1	4	mA
Op. Current (Crystal Type)	I _{OP3}	No load (Ext-V) In dual-clock slow operation and F _m is stopped	-	8.5	20	μA
Hold Current (Crystal Type)	I _{HM1}	Hold mode No load (Ext-V) In dual-clock normal operation	-	280	450	μA
Hold Current (RC Type)	I _{HM2}	Hold mode No load (Ext-V) In dual-clock normal operation	-	500	600	μA
Hold Current (Crystal Type)	I _{HM3}	Hold mode No load (Ext-V) In dual-clock slow operation and F _m is stopped	-	4.0	6	μA
Stop Current (Crystal)	I _{SM}	Stop mode No load (Ext-V) In single-clock operating	-	0.1	2	μA
Input Low Voltage	V _{IL}	-	V _{SS}	-	0.3 V _{DD}	V
Input High Voltage	V _{IH}	-	0.7 V _{DD}	-	V _{DD}	V



MFP Output Low Voltage	VML	IOL = 2.7 mA	-	-	0.4	V
MFP Output High Voltage	VMH	IOH = 3.5 mA	2.4	-	-	V

DC Characteristics, continue

PARAMETER	SYM.	CONDITIONS	MIN.	TYP.	MAX.	UNIT
Port RA, RB Output Low Voltage	VABL	IOL = 2.0 mA	-	-	0.4	V
Port RA, RB Output High Voltage	VABH	IOH = 2.0 mA	2.4	-	-	V
LCD Supply Current	ILCD	All Seg. ON	-	-	6	μA
SEG0–SEG31 Sink Current (Used as LCD Output)	IOL1	VOL = 0.4V VLCD = 0.0V	0.4	-	-	μA
SEG0–SEG31 Drive Current (Used as LCD Output)	IOH1	VOH = 2.4V VLCD = 3.0V	0.3	-	-	μA
Segment Output Low Voltage (Used as DC Output)	VSL	IOL = 0.6 mA	-	-	0.4	V
Segment Output High Voltage (Used as DC Output)	VSH	IOH = 3 μA	2.4	-	-	V
Port RE Sink Current	IEL	VOL = 0.9V	7.5	-	-	mA
Port RE Source Current	IEH	VOH = 2.4V	0.4	1.2	-	mA
Pull-up Resistor	RCD	Port RC, RD	100	350	1000	KΩ
RES Pull-up Resistor	RRES	-	20	100	500	KΩ

AC CHARACTERISTICS

(V_{DD}–V_{SS} = 3.0V, F_m = 4 MHz, F_s = 32.768 KHz, T_A = 25° C, LCD on; unless otherwise specified)

PARAMETER	SYM.	CONDITIONS	MIN.	TYP.	MAX.	UNIT
Op. Frequency	FOSC	RC type	-	4000	-	KHz
		Crystal type 1 (Option low speed type)	-	32.768	-	
		Crystal type 2 (Option high speed type)	400	-	4190	
Frequency Deviation by Voltage Drop for RC Oscillator	$\frac{\Delta f}{f}$	$\frac{f(3V) - f(2.4V)}{f(3V)}$	-	-	10	%
Instruction Cycle Time	T _I	One machine cycle	-	4/FOSC	-	S

W541C260



Reset Active Width	TRAW	FOSC = 32.768 KHz	1	-	-	μS
Interrupt Active Width	TIAW	FOSC = 32.768 KHz	1	-	-	μS

TYPICAL APPLICATION CIRCUIT

