

Features

- Complete ADSL differential driver and receiver
- 54V_{p-p} output drive into 100Ω differential
- 50V_{p-p} output drive into 50Ω differential
- Driver 2nd/3rd harmonics of -70dBc/-75dBc at 2V_{p-p} into 100Ω
- Low supply current - 12.5mA per drive amplifier and 5mA per receive amplifier
- Standard surface-mount package

Applications

- ADSL line driver
- HDSL2 line driver
- Video distribution amplifier

Ordering Information

Part No	Package	Tape & Reel	Outline #
EL1502CM	20-Lead SO		MDP0027

General Description

The EL1502C is a complete transceiver solution for high speed data transmission over twisted pair wires. It contains two wideband, high-voltage drivers and two low-noise receive amplifiers. The EL1502C is ideally suited for both ADSL and HDSL2 applications, in which it can supply a 50V_{p-p} signal into a 50Ω differential load while exhibiting very low distortion. The receive amplifiers also have very low distortion and low-noise for superior reception of small signals.

The line drivers of the EL1502C are current-feedback type amplifiers, which achieve a high slew rate while consuming moderate power. They retain their frequency response over a wide range of externally set gains. The receive amplifiers are of the voltage-feedback type and can be used to implement a hybrid coupler or filter functions using external passive components.

The EL1502C operates on ±5V to ±15V supplies. It retains its bandwidth and linearity over the complete supply range.

The device is supplied in a standard form factor, 20-pin SOIC package. The eight center package pins of the package are used as ground connections and heat spreaders, allowing for operation over the full -40°C to +85°C temperature range.

Connection Diagrams

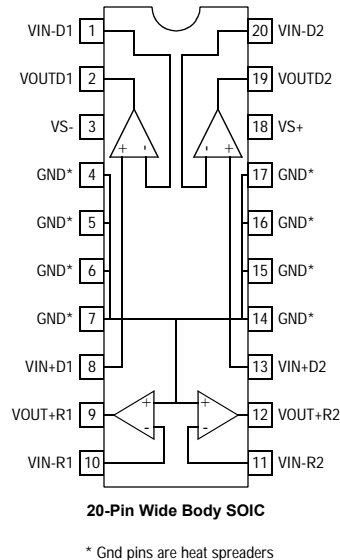

Note: All information contained in this data sheet has been carefully checked and is believed to be accurate as of the date of publication; however, this data sheet cannot be a "controlled document". Current revisions, if any, to these specifications are maintained at the factory and are available upon your request. We recommend checking the revision level before finalization of your design documentation.

EL1502C - Product Brief

High Power Differential Line Driver/Receiver

General Disclaimer

Specifications contained in this data sheet are in effect as of the publication date shown. Elantec, Inc. reserves the right to make changes in the circuitry or specifications contained herein at any time without notice. Elantec, Inc. assumes no responsibility for the use of any circuits described herein and makes no representations that they are free from patent infringement.

élantec

HIGH PERFORMANCE ANALOG INTEGRATED CIRCUITS

Elantec Semiconductor, Inc.

675 Trade Zone Blvd.

Milpitas, CA 95035

Telephone: (408) 945-1323

(888) ELANTEC

Fax: (408) 945-9305

European Office: +44-118-977-6020

Japan Technical Center: +81-45-682-5820

WARNING - Life Support Policy

Elantec, Inc. products are not authorized for and should not be used within Life Support Systems without the specific written consent of Elantec, Inc. Life Support systems are equipment intended to support or sustain life and whose failure to perform when properly used in accordance with instructions provided can be reasonably expected to result in significant personal injury or death. Users contemplating application of Elantec, Inc. Products in Life Support Systems are requested to contact Elantec, Inc. factory headquarters to establish suitable terms & conditions for these applications. Elantec, Inc.'s warranty is limited to replacement of defective components and does not cover injury to persons or property or other consequential damages.